

TECHNICAL MANUAL

**AVIATION UNIT AND
AVIATION INTERMEDIATE
MAINTENANCE MANUAL**

**ENGINE, GAS TURBINE
MODEL T55-L-712
NSN 2840-01-030-4890**

HEADQUARTERS, DEPARTMENT OF THE ARMY

26 APRIL 1983

WARNING AND FIRST AID DATA

Warnings, cautions and notes emphasize important and critical instructions. They are defined as follows:

WARNING

An operating procedure or practice which, if not correctly followed, will result in personnel injury or loss of life.

CAUTION

An operating procedure or practice which, if not strictly observed, will result in damage or destruction of equipment.

NOTE

An operating procedure or condition which it is essential to highlight.

Personnel performing instructions involving operations, procedures, materials, and practices which are included or implied in this technical manual shall observe the following instructions. Disregard of these warnings and precautionary information can cause serious injury or death. Refer to FM 21-11 for first aid data to treat injuries resulting from working on the engine.

WARNING

Fuels

- Turbine fuels are very flammable. They may cause drying and irritation of skin or eyes.
- Handle only in well-ventilated areas away from heat and open flame.
- Drain and store in approved metal safety containers.
- Avoid prolonged or repeated contact with skin and do not take internally.
- Wash contacted area of skin thoroughly after handling. If irritation of skin results, get medical attention. Get medical attention for eyes.

WARNING

Lubricating Oils

- Lubricating oils cause paralysis if swallowed. Prolonged contact with them may irritate the skin.
- Handle only in well-ventilated areas away from heat and flame.
- Drain and store in approved metal safety containers.
- Avoid prolonged or repeated contact with skin and do not take internally.
- Wash contacted areas of skin thoroughly after handling. If irritation of skin results, get medical attention. Get medical attention for eyes.

WARNING

Dangerous Voltages

- The ignition exciter stores very high and possibly fatal voltage. Use extreme care when working around spark and ignition exciters.
- Serious injury could result if exciter or igniters are improperly discharged or accidentally grounded.
- Do not probe inside of output receptacles, ignition leads, or spark igniters with finger or metal objects.
- Discharge exciter only with insulated screwdriver.
- In case of shock or injury, get medical attention.

WARNING

Discharging Ignition Exciter

- When discharging ignition exciter, remove one lead at a time and discharge receptacle that lead was removed from. Failure to do so may result in serious shock when you are removing second lead.
- In case of serious shock, get medical attention.

WARNING**Compressed Air**

- When using compressed air for cleaning, use approved protective equipment for eyes and face.
- Do not use more than 30 psig air pressure.
- Do not direct air toward yourself or another person. Failure to comply could result in injury to eyes or skin.
- In case of injury, get medical attention.

WARNING**Corrosion Preventive Compounds**

- These materials are flammable and toxic.
- Use only in well-ventilated area away from heat, sparks and open flames.
- If swallowed, do not induce vomiting. Get medical attention.
- In case of contact immediately flush skin and eyes with water for 15 minutes. Get medical attention for eyes.

WARNING**Cleaning Solvents**

- These materials are flammable and toxic. They can irritate skin and cause burns.
- Use only in well-ventilated area, away from heat, sparks and open flame.
- In case of contact, immediately flush skin and eyes with water for at least 15 minutes. Get medical attention for eyes.

WARNING

Handling of Heated Parts

- Wear asbestos gloves when handling heated parts for assembly and disassembly. Failure to comply may cause severe burns.
- Get medical attention for burns.

WARNING

Handling of Parts Treated with Dry Ice

- Dry ice is very cold. It can cause severe burns.
- Wear approved protective equipment and handle only in well-ventilated areas. Get medical attention for burns.

WARNING

Handling of Spring Loaded Parts

- Be careful when removing and installing retaining ring to spring loaded parts.
- Spring tension could cause parts to spring up and cause injury.
- If injury occurs, get medical attention.

WARNING

Nitric Acid

- Both nitric acid and its vapors are a personnel hazard.
- Avoid contact with skin, eyes or clothing. Avoid inhalation of vapors.
- In case of contact, immediately flush skin and eyes with water for at least 15 minutes. Get medical attention.

WARNING

Handling Engine Shipping Container

- Be careful when working with engine shipping container. Make sure both sections of container are grounded.
- Make sure container is opened in well-ventilated area. Failure to do so could result in explosion.
- Shipping container is pressurized. Make certain that all air pressure has been released before removing valve stem or loosening nuts. If nuts are removed before pressure is released, internal pressure could blow cover off and cause serious injury.
- If injury occurs, get medical attention.

WARNING

Handling of Skimming Maintenance Kit

- Contact with skimming maintenance kit rotating parts could cause injury. Exposure to maintenance kit noise may cause ringing in ears, and temporary or permanent hearing loss.
- Keep hands and clothing away from rotating parts and wear approved hearing protection.
- If injury occurs, or ringing in ears or loss of hearing persists, get medical attention.

WARNING

Sodium Bichromate

- Sodium bichromate is highly toxic, do not take internally.
- Use only with adequate ventilation. Avoid prolonged or repeated contact with skin.
- Wear approved gloves and goggles, or face shield and apron, and wash hands thoroughly after handling.
- Wear respirator if sodium bichromate is in powdered form.
- In case of contact, immediately flush skin and eyes with water for at least 15 minutes. Get medical attention.

WARNING

Welding Operations

- Welding operations are hazardous. Harmful light rays may injure eyes and burn skin. Poisonous fumes may cause illness. Burns and fires may result from hot sparks.
- Wear approved protective clothing and equipment.
- Perform welding operations in well-ventilated areas away from flammable liquids and gases.
- If fire occurs, call for assistance and use proper extinguishing procedures.
- If injury or illness occurs, get medical attention.

WARNING

Use of Engine Maintenance Sling

- Inspect sling prior to use for signs of abuse or wear. Failure to comply may cause injury to personnel and/or damage to engine.
- When using sling, make sure hoist lifting capacity is-l 200 pounds.
- In case of injury get medical attention.

WARNING

Power Grinding

- Power grinding is hazardous to personnel. Sparks and metal chips may injure eyes.
- Wear approved goggles.
- If injury occurs, get medical attention.

WARNING

Handling Torque Multiplier

- Make sure handle is fully seated and ratchet selector on torque pack is properly set before applying torque. Rotating ratchet selector with load on torque pack may damage unit and injure personnel.
- Do not change ratchet selector when torque load is on torque pack.
- If injury occurs, get medical attention.

WARNING

Flight Safety Critical Aircraft Parts (FSCAP)

The T-55 flight safety critical aircraft parts inclusion in this manual will be restricted to the flight safety critical aircraft parts section, including Table 1. Warnings will not be included throughout the manual. Flight safety critical air-craft parts require special handling during maintenance and compliance to all maintenance procedures are mandatory.

CHANGE
NO. 9

HEADQUARTERS
DEPARTMENT OF THE ARMY
WASHINGTON, D.C. 15 November 2005

AVIATION UNIT AND AVIATION INTERMEDIATE
MAINTENANCE MANUAL

ENGINE, GAS TURBINE, MODEL T55-L-712
NSN 2840-01-030-4890

DISTRIBUTION STATEMENT A: Approved for public release; distribution is unlimited.

TM 55-2840-254-23-2, dated 26 April 1983, is changed as follows:

1. Remove and insert pages as indicated below. New or changed text material is indicated by a vertical bar in the margin. An illustration change is indicated by a miniature pointing hand.

Remove pages

A and B

2-348.1(2-348.2 Blank)

Insert pages

A and B

2-348.1(2-348.2 Blank)

2. Retain this sheet in front of manual for reference purposes.

By Order of the Secretary of the Army:

Official:



SANDRA R. RILEY

*Administrative Assistant to the
Secretary of the Army*

0517402

PETER J. SCHOOMAKER
*General, United States Army
Chief of Staff*

DISTRIBUTION:

To be distributed in accordance with Initial Distribution Number (IDN) 310747 requirements for TM 55-2840-254-23-2.

CHANGE

NO. 8

HEADQUARTERS
DEPARTMENT OF THE ARMY
WASHINGTON, D.C., 30 October 2003

Aviation Unit and Aviation Intermediate
Maintenance Manual

ENGINE, GAS TURBINE, MODEL T55-L-712
(NSN 2840-01-030-4890)

OZONE DEPLETING CHEMICAL INFORMATION

This document has been reviewed for the presence of class I ozone depleting chemicals. As of the basic through change 05, dated 30 September 1996, all references to Class I ozone depleting chemicals have been removed from this document by substitution with chemicals by the Engineering, Environment, and Logistics Oversight Office that do not cause atmospheric ozone depletion.

DISTRIBUTION STATEMENT A: Approved for public release; distribution is unlimited

TM 55-2840-254-23-2, 26 April 1983, is changed as follows:

1. Remove and insert pages as indicated below. New or changed text material is indicated by a vertical bar in the margin. An illustration change is indicated by a miniature pointing hand.

Remove pages

A and B

2-231 and 2-232

--

Insert pages

A and B

2-231 and 2-232

2-348.1 and 2-348.2 Blank

2. Retain this sheet in front of manual for reference purposes.

By Order of the Secretary of the Army:

Official:

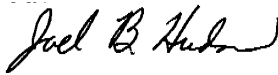

JOEL B. HUDSON

*Administrative Assistant to the
Secretary of the Army*

0323801

PETER J. SCHOOMAKER
*General, United States Army
Chief of Staff*

DISTRIBUTION:

To be distributed in accordance with Initial Distribution Number (IDN) 310747, requirements for TM 55-2840-254-23-2.

CHANGE
NO. 7

HEADQUARTERS
DEPARTMENT OF THE ARMY
WASHINGTON, D.C., 15 November 2002

Aviation Unit and Aviation Intermediate
Maintenance Manual
ENGINE, GAS TURBINE, MODEL T55-L-712
(NSN 2840-01-030-4890)

OZONE DEPLETING CHEMICAL INFORMATION

This document has been reviewed for the presence of class I ozone depleting chemicals. As of the basic through change 05, dated 30 September 1996, all references to Class I ozone depleting chemicals have been removed from this document by substitution with chemicals by the Engineering, Environment, and Logistics Oversight Office that do not cause atmospheric ozone depletion.

DISTRIBUTION STATEMENT A: Approved for public release; distribution is unlimited

TM 55-2840-254-23-2, 26 April 1983, is changed as follows:

1. Remove and insert pages as indicated below. New or changed text material is indicated by a vertical bar in the margin. An illustration change is indicated by a miniature pointing hand.

Remove pages	Insert pages
--	A and B
i and ii	i and ii
2-45 and 2-46	2-45 and 2-46
2-187 and 2-188	2-187 and 2-188
2-231 and 2-232	2-231 and 2-232
2-254.1 and 2-254.2	2-254.1 and 2-254.2
2-455 through 2-470	2-455 through 2-470
2-489 through 2-496	2-489 through 2-496

2. Retain this sheet in front of manual for reference purposes.

By Order of the Secretary of the Army:

Official:

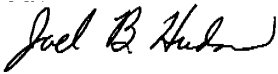
JOEL B. HUDSON
Administrative Assistant to the
Secretary of the Army
0227603

ERIC K. SHINSEKI
General, United States Army
Chief of Staff

DISTRIBUTION:

To be distributed in accordance with Initial Distribution Number (IDN) 310747, requirements for TM 55-2840-254-23.

CHANGE
NO. 6

HEADQUARTERS
DEPARTMENT OF THE ARMY
WASHINGTON, D.C., 30 SEPTEMBER 1996

Aviation Unit and Aviation Intermediate
Maintenance Manual

**ENGINE, GAS TURBINE
MODEL T55-L-712
NSN 2840-01-030-4890**

DISTRIBUTION STATEMENT A: Approved for public release; distribution is unlimited

TM 55-2840-254-23-2, 26 April 1983, is changed as follows:

1. Remove and insert pages as indicated below. New or changed text material is indicated by a vertical bar in the margin. An illustration change is indicated by a miniature pointing hand.

Remove pages g/(h blank) i through iv	Insert pages g/(h blank) i through iv
2-153 and 2-154	2-153 and 2-154
2-157 and 2-158	2-157 and 2-158
2-163 and 2-164	2-163 and 2-164
2-231 and 2-232	2-231 and 2-232
2-285 and 2-286	2-285 and 2-286
- - -	2-286.1/(2-286.2 blank)
2-323 and 3-324	2-323 and 2-324
2-331 and 2-332	2-331 and 2-332
2-389 and 2-390	2-389 and 2-390
2-431 through 2-434	2-431 through 2-434
2-455 through 2-458	2-455 through 2-458
2-483 and 2-484	2-483 and 2-484
2-497 and 2-498	2-497 and 2-498
Index-i through Index-16	Index-1 through Index-16.1/(Index 16.2 blank)
Index 16.1/(Index 16.2 blank)	
Index-17 through Index-32	Index-17 through Index-32

2. Retain this sheet in front of manual for reference purposes.

TM 55-2840-254-23-2

C6

By order of the secretary of the army

DENNIS J. REIMER
General United States Army
Chief of Staff

Official

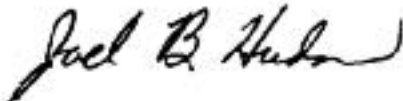

Administrative Assistant to the
Secretary of the Army
02598

DISTRIBUTION:

To be distributed in accordance with DA Form 12-31E, block no. 0747, requirements for TM 55-2840-254-23-2.

CHANGE

NO. 5

HEADQUARTERS
DEPARTMENT OF THE ARMY
WASHINGTON, D.C., 30 SEPTEMBER 1993

Aviation Unit and Aviation Intermediate
Maintenance Manual

ENGINE, GAS TURBINE
MODEL T55-L-712
NSN 2840-01-030-4890

DISTRIBUTION STATEMENT A: Approved for public release; distribution is unlimited.

TM 55-2840-254-23-2, 26 April 1983, is changed as follows:

1. Remove and insert pages as indicated below. New or changed text material is indicated by a vertical bar in the margin. An illustration change is indicated by a miniature pointing hand.

Remove pages	Insert pages
2-5 through 2-12 ----	2-5 through 2-12 2-12.1 through 2-12.7/ (2-12.8 blank)
2-17 and 2-18 ----	2-17 and 2-18 2-18.1/(2-18.2 blank)
2-21 through 2-28 ----	2-21 through 2-28 2-28.1 through 2-28.7/ (2-28.8 blank)
2-29 through 2-40 ----	2-29 through 2-40 2-40.1 through 2-40.13/ (2-40.14 blank)
2-145 and 2-146	2-145 and 2-146
2-155 through 2-158	2-155 through 2-158
2-219 and 2-220	2-219 and 2-220
2-231 through 2-236	2-231 through 2-236
2-239 and 2-240	2-239 and 2-240
2-249 through 2-254 ----	2-249 through 2-254 2-254.1 through 2-254.28
2-331 and 2-332	2-331 and 2-332
2-347 and 2-348	2-347 and 2-348
2-389 and 2-390	2-389 and 2-390
2-484	2-483 and 2-484
2-497 and 2-498 ----	2-497 and 2-498 2-498.1/(2-498.2 blank)
2-525 and 2-526 ----	2-525 and 2-526 2-526.1/(2-526.2 blank)
2-529 through 2-532	2-529 through 2-532
2-551 through 2-555/ (2-556 blank) ----	2-551 through 2-556 2-556.1 through 2-556.60
Index-1 through Index-37/ (Index-38 blank)	Index-1 through Index-36

2. Retain this sheet in front of manual for reference purposes.

By Order of the Secretary of the Army:

GORDON R. SULLIVAN
General, United States Army
Chief of Staff

Official:

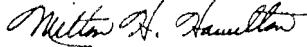

MILTON H. HAMILTON
Administrative Assistant to the
Secretary of the Army

05335

DISTRIBUTION :

To be distributed in accordance with DA Form 12-31-E, block no. 0747, requirements for TM 55-2840-254-23-2.

CHANGE }
NO. 4 }

HEADQUARTERS
DEPARTMENT OF THE ARMY
WASHINGTON, D.C., 11 December 1990

Aviation Unit and Aviation Intermediate
Maintenance Manual

ENGINE, GAS TURBINE
MODEL T55-L-712
NSN 2840-01-030-4890

TM 55-2840-254-23-2, 26 April 1983, is changed as follows:

1. Remove and insert pages as indicated below. New or changed text material is indicated by a vertical bar in the margin. An illustration change is indicated by a miniature pointing hand.

Remove pages

Insert pages

2-491 and 2-492

2-491 and 2-492

2. Retain this sheet in front of manual for reference purposes.

By Order of the Secretary of the Army:

CARL E. VUONO
General, United States Army
Chief of Staff

Official:

THOMAS F. SIKORA
Brigadier General, United States Army
The Adjutant General

DISTRIBUTION:

To be distributed in accordance with DA Form 12-31A, AVUM and AVIM Maintenance requirements for Engine, Gas Turbine, T55-L-712 (TM 55-2840-254-Series).

CHANGE }
 NO. 3 }

HEADQUARTERS
 DEPARTMENT OF THE ARMY
 WASHINGTON, D.C., 13 June 1990

Aviation Unit and Aviation Intermediate
 Maintenance Manual

ENGINE, GAS TURBINE
 MODEL T55-L-712
 NSN 2840-01-030-4890

TM 55-2840-254-23-2, 26 April 1983, is changed as follows:

1. Remove and insert pages as indicated below. New or changed text material is indicated by a vertical bar in the margin. An illustration change is indicated by a miniature pointing hand.

Remove pages

2-283 and 2-284

Insert pages

2-283 and 2-284

2. Retain this sheet in front of manual for reference purposes.

By Order of the Secretary of the Army:

Official:

WILLIAM J. MEEHAN II
Brigadier General, United States Army
The Adjutant General

CARL E. VUONO
General, United States Army
Chief of Staff

DISTRIBUTION:

To be distributed in accordance with DA Form 12-31A, AVUM and AVIM Maintenance requirements for Engine, Gas Turbine, T55-L-712 (TM 55-2840-254-Series).

CHANGE

NO. 2

HEADQUARTERS
DEPARTMENT OF THE ARMY
WASHINGTON, D.C., 30 May 1990

Aviation Unit and Aviation Intermediate
Maintenance Manual

ENGINE, GAS TURBINE
MODEL T55-L-712
NSN 2840-01-030-4890

TM 55-2840-254-23-2, 26 April 1983, is changed as follows:

1. Remove and insert pages as indicated below. New or changed text material is indicated by a vertical bar in the margin. An illustration change is indicated by a miniature pointing hand.

Remove pages

xiii and xiv
2-231 and 2-232
2-249 and 2-250
2-443 and 2-444
2-453 and 2-454
Index-3 and Index-4
Index-11 and Index-12
Index-19 and Index-20
Index-23 and Index-24
Index-27 through Index-30
Index-35 and Index-36

Insert pages

xiii and xiv
2-231 and 2-232
2-249 and 2-250
2-443 and 2-444
2-453 and 2-454
Index-3 and Index-4
Index-11 and Index-12
Index-19 and Index-20
Index-23 and Index-24
Index-27 through Index-30
Index-35 and Index-36

2. Retain this sheet in front of manual for reference purposes.

By Order of the Secretary of the Army:

Official:

CARL E. VUONO
General, United States Army
Chief of Staff

WILLIAM J. MEEHAN II
Brigadier General, United States Army
The Adjutant General

DISTRIBUTION:

To be distributed in accordance with DA Form 12-31A, AVUM and AVIM Maintenance requirements for Engine, Gas Turbine, T55-L-712 (TM 55-2840-254-Series).

CHANGE }
NO. 1 }

HEADQUARTERS
DEPARTMENT OF THE ARMY
WASHINGTON, D.C., 12 June 1989

Aviation Unit and Aviation Intermediate
Maintenance Manual

ENGINE, GAS TURBINE
MODEL T55-L-712
NSN 2840-01-030-4890

TM 55-2840-254-23-2, 26 April 1983, is changed as follows:

1. Remove and insert pages as indicated below. New or changed text material is indicated by a vertical bar in the margin. An illustration change is indicated by a miniature pointing hand.

Remove pages	Insert pages
2-51 through 2-54	2-51 through 2-54
2-65 through 2-68	2-65 through 2-68
2-161 and 2-162	2-161 and 2-162
-----	2-162.1/2-162.2
2-187 through 2-190	2-187 through 2-190
-----	2-190.1 through 2-190.3/2-190.4
2-367 through 2-369/2-370	2-367 through 2-369/2-370
2-369 and 2-370	2-369 and 2-370
2-381 and 2-382	2-381 and 2-382
Index 1 through Index 6	Index 1 through Index 6
Index 15 through Index 20	Index 15 through Index 20
Index 25 through Index 30	Index 25 through Index 30
Index 33 and Index 34	Index 33 and Index 34

2. Retain this sheet in front of manual for reference purposes.

By Order of the Secretary of the Army:

CARL E. VUONO
General, United States Army
Chief of Staff

Official:

WILLIAM J. MEEHAN II
Brigadier General, United States Army
The Adjutant General

DISTRIBUTION:

To be distributed in accordance with DA Form 12-31A, AVUM and AVIM Maintenance requirements for Engine, Gas Turbine, T55-L-712 (TM 55-2840-254 Series).

LIST OF EFFECTIVE PAGES

Insert latest changed pages; dispose of superseded pages in accordance with regulations.

NOTE: On changed pages, a vertical line or other change symbol in the outer margin of the page indicates the portion of the text affected by the latest change. Changes to illustrations are indicated by miniature pointing hands. Shaded areas indicate changes to wiring diagrams.

Dates of issue for original and changed pages are:

Original..... 0	26 April 1983	Change..... 5	30 Sep 1993
Change 1	12 June 1989	Change..... 6	30 Sep 1996
Change 2	30 May 1990	Change..... 7	15 Nov 2002
Change 3	13 June 1990	Change..... 8	30 Oct 2003
Change 4	11 Dec 1990	Change 9	15 Nov 2005

Page No.	*Change No.	Page No.	*Change No.
Cover	0	2-162.1	1
A and B	9	2-162.2 blank	1
a through f.....	0	2-163	0
g.....	6	2-164	6
h blank	6	2-165 through 2-186	0
i.....	7	2-187 and 2-188.....	7
ii through iv	6	2-189.....	0
v through xiii.....	0	2-190.....	1
xiv	2	2-190.....	1
2-1 through 2-4	0	2-190.1 through 2-191.3	1
2-5 through 2-12.7	5	2-190.4 blank	1
2-12.8 blank	5	2-191 through 2-217	0
2-13 through 2-16	0	2-218.....	0
2-17 and 2-18	5	2-219 and 2-220.....	5
2-18.1	5	2-221 through 2-223	0
2-18.2 blank	5	2-231	8
2-19 and 2-20	0	2-232.....	7
2-21 through 2-40.13	5	2-233.....	0
2-40.14 blank	5	2-234.....	5
2-41 through 2-45	0	2-235.....	0
2-46.....	7	2-236.....	5
2-47 through 2-51	0	2-237 through 2-239	0
2-52 and 2-53	1	2-240.....	5
2-54 through 2-65	0	2-241 through 2-248	0
2-66.....	1	2-249.....	5
2-67.....	0	2-250.....	2
2-68.....	1	2-251 through 2-253	5
2-69 through 2-153	0	2-254.....	0
2-154.....	6	2-254.1	7
2-155.....	0	2-254.2 through 2-254.28	5
2-156 and 2-157	5	2-255 through 2-282	0
2-158.....	6	2-283.....	3
2-159 and 2-160	0	2-284.....	0
2-161 and 2-162	1	2-285 and 2-286.....	6

*Zero in this column indicates an original page.

LIST OF EFFECTIVE PAGES (Continued)

Page No.	*Change No.	Page No.	*Change No.
2-286.1.....	6	2-453 and 2-454.....	2
2-286.2 blank.....	6	2-470 through 2-482.....	0
2-287 through 2-323.....	0	2-483 and 2-484.....	6
2-324.....	6	2-485 through 2-489.....	0
2-325 through 2-330.....	0	2-490 through 2-496.....	7
2-331 and 2-332.....	6	2-497.....	0
2-333 through 2-347.....	0	2-498.....	6
2-348.....	5	2-498.1.....	5
2-348.1.....	9	2-498.2 blank.....	5
2-348.2 blank.....	9	2-499 through 2-525.....	0
2-349 through 2-367.....	0	2-526.....	5
2-368 through 2-369.....	1	2-526.1.....	5
2-370 blank.....	1	2-526.2 blank.....	5
2-371 through 2-381.....	0	2-527 through 2-529.....	0
2-382.....	1	2-530 and 2-531.....	5
2-383 and 2-389.....	0	2-532 through 2-550.....	0
2-390.....	6	2-551.....	5
2-391 through 2-430.....	0	2-552 and 2-553.....	0
2-431.....	6	2-554.....	5
2-432.....	0	2-555.....	0
2-435 through 2-443.....	0	2-556.....	5
2-444.....	2	2-556.1 through 2-556.60.....	5
2-445 through 2-452.....	0	Index 1 through Index 32.....	6
2-445 through 2-452.....	0		

*Zero in this column indicates an original page.

TECHNICAL MANUAL
Aviation Unit and Aviation Intermediate Maintenance Manual
ENGINE, GAS TURBINE
MODEL T55-L-712
(NSN 2840-01-030-4890)

REPORTING ERRORS AND RECOMMENDING IMPROVEMENTS

You can help improve this manual. If you find any mistakes, or if you know of a way to improve these procedures, please let us know. Mail your letter or DA Form 2028 (Recommended Changes to Publications and Blank Forms), or DA Form 2028-2 located in the back of this manual directly to: Commander, US Army Aviation and Missile Command, ATTN: AMSAM-MMC-MA-NP, Redstone Arsenal, AL 35898-5000. A reply will be furnished to you. You may also provide DA Form 2028 information to AMCOM via e-mail, fax, or the World Wide Web. Our fax number is: DSN 788-6546 or Commercial 256-842-6546. Our e-mail address is: 2028@redstone.army.mil. Instructions for sending an electronic 2028 may be found at the back of this manual immediately preceding the hard copy 2028. For the World Wide Web use: <https://amcom2028.redstone.army.mil>.

OZONE DEPLETING CHEMICAL INFORMATION

This document has been reviewed for the presence of class I ozone depleting chemicals. As of the basic through change 05, dated 30 September 1996, all references to Class I ozone depleting chemicals have been removed from this document by substitution with chemicals by the Engineering, Environment, and Logistics Oversight Office that do not cause atmospheric ozone depletion.

DISTRIBUTION STATEMENT A: Approved for public release; distribution is unlimited

TABLE OF CONTENTS

	PAGE
HOW TO USE THIS MANUAL	vii
CHAPTER I. INTRODUCTION	1-1
Chapter Overview	1-1
Section I General Information	1-1
Section II Equipment Description and Data	1-3
Section III Principles of Operation	1-13
Section IV Repair Parts; Special Tools; Test, Measurement, and Diagnostic Equipment (TMDE); and Support Equipment	1-41
Section V Service Upon Receipt	1-43
Section VI Hoisting	1-109
Section VII Troubleshooting	1-119
Section VIII Servicing	1-219
Section IX Preventive Maintenance Checks and Services	1-239
Section X Maintenance Procedures	1-443
Section XI Preparation for Storage and Shipment	1-553
Section XII Standard Torque Limits	1-623
Section XIII Standard Practices and Procedures	1-627

NOTE

This manual is printed in four volumes as follows:

TM 55-2840-254-23-1, consisting of Warning Pages, Table of Contents, Chapter 1, and Alphabetical Index.

TM 55-2840-254-23-2, consisting of Warning Pages, Table of Contents, Chapter 2, and Alphabetical Index.

TM 55-2840-254-23-3, consisting of Warning Pages, Table of Contents, Chapter 3 through 5 and Alphabetical Index.

TM 55-2840-254-23-4, consisting of Warning Pages, Table of Contents, Chapter 6 through 9, Appendixes A through F, Glossary, and Alphabetical Index.

TABLE OF CONTENTS (Continued)

	Page
CHAPTER 2	COMPRESSOR SECTION – MAINTENANCE INSTRUCTIONS 2-1
	Chapter Overview 2-1
Section I	Interstate Air-Bleed Actuator - Maintenance Procedures 2-5
Section II	Compressor Bleed Band - Maintenance Procedures 2-41
Section III	Anti-Icing Air Gallery Cover - Maintenance Procedures 2-51
Section IV	Compressor Housing - Maintenance Procedures 2-71
Section V	Stator Vane Assemblies - Maintenance Procedures 2-219
Section VI	Compressor Rotor Blades - Maintenance Procedures 2-255
Section VII	Air Diffuser Assembly - Maintenance Procedures 2-351
Section VIII	No. 2 Bearing Package - Maintenance Procedures 2-395
Section IX	Output Shaft Seal and Housing Assembly - Maintenance Procedures 2-431
Section X	Inlet Housing Cover Assembly - Maintenance Procedures 2-455
Section XI	Output Shaft Support Housing - Maintenance Procedures 2-465
Section XII	Air Inlet Housing Assembly - Maintenance Procedures 2-497
Section XIII	No. 3 Bearing Package - Maintenance Procedures 2-501
Section XIV	Air Lines - Maintenance Procedures 2-525
CHAPTER 3	COMBUSTION SECTION – MAINTENANCE INSTRUCTIONS 3-1
	Chapter Overview 3-1
Section I	Fuel Drain Valve- Maintenance Procedures 3-3
Section II	Combustion Section and Power Turbine Maintenance Procedures 3-11
Section III	Combustion Section - Maintenance Procedures 3-151
Section IV	Combustion Chamber Vane Assembly - Maintenance Procedures 3-171
Section V	Combustion Chamber Liner - Maintenance Procedures 3-183
Section VI	Combustion Chamber Housing - Maintenance Procedures 3-213
CHAPTER 4	TURBINE SECTION –MAINTENANCE INSTRUCTIONS 4-1
	Chapter Overview 4-1
Section I	Thermocouple Jumper Lead - Maintenance Procedures 4-5
Section II	Left- and Right-Hand Bus Bar Assemblies – Maintenance Procedures 4-35
Section III	Fireshield Assembly - Maintenance Procedures 4-65
Section IV	Fireshield Section - Maintenance Procedures 4-79
Section V	Thermocouple Harness Assemblies - Maintenance Procedures 4-97
Section VI	Third Turbine Nozzle and Support - Maintenance Procedures 4-123
Section VII	Fourth Stage Power Turbine Rotor - Maintenance Procedures 4-151
Section VIII	No. 4 and 5 Bearing Package - Maintenance Procedures 4-185
Section IX	Fourth Stage Power Turbine Nozzle - Maintenance Procedures 4-269
Section X	Third Stage Power Turbine Rotor - Maintenance Procedures 4-303
Section XI	Second Turbine Disc Assembly - Maintenance Procedures 4-313
Section XII	Second Turbine Nozzle, Spacer, and Case - Maintenance Procedures 4-335

TABLE OF CONTENTS (Continued)

	Page
CHAPTER 4 (Continued)	
Section XIII	First Turbine Disc Assembly - Maintenance Procedures 4-397
Section XIV	First Turbine Nozzle - Maintenance Procedures 4-429
Section XV	Field Replacement First and Second Turbine Disc Assembly - Maintenance Procedures 4-469
Section XVI	Diffuser Curl - Maintenance Procedures 4-479
Section XVII	Exit Vane Assembly - Maintenance Procedures 4-489
CHAPTER 5 ACCESSORY GEAR SECTION – MAINTENANCE INSTRUCTIONS 5-1	
	Chapter Overview 5-1
Section I	Accessory Gearbox Assembly - Maintenance Procedures 5-3
Section II	Accessory Gear Assembly - Maintenance Procedures 5-45
Section III	Starter Drive Assembly - Maintenance Procedures 5-81
Section IV	Overspeed Drive and Outlet Cover Assembly - Maintenance Procedures 5-99
CHAPTER 6 FUEL SYSTEM –MAINTENANCE INSTRUCTIONS 6-1	
	Chapter Overview 6-1
Section I	Fuel Control - Maintenance Procedures 6-5
Section II	Fuel Control - Preparation for Storage or Shipment 6-31
Section III	Fuel Boost Pump Assembly - Maintenance Procedures 6-39
Section IV	Fuel Boost Pump Assembly - Preparation for Storage or Shipment 6-55
Section V	Left- and Right-Hand Fuel Manifold Assemblies - Maintenance Procedures 6-57
Section VI	Primer Tube Assembly – Maintenance Procedures 6-101
Section VII	Start Fuel Nozzles - Maintenance Procedures 6-111
Section VIII	Main Fuel Filter and Bracket - Maintenance Procedures 6-119
section IX	In-Line Fuel Filter Assembly - Maintenance Procedures 6-141
Section X	Flow Divider and Bracket - Maintenance Procedures 6-159
Section XI	Fuel Check Valve - Maintenance Procedures 6-171
Section XII	Starting Fuel Solenoid Valve - Maintenance Procedures 6-177
Section XIII	Fuel Lines - Maintenance Procedures 6-189
CHAPTER 7 ELECTRICAL AND IGNITION SYSTEMS – MAINTENANCE INSTRUCTIONS 7-1	
	Chapter Overview 7-1
section I	Ignition Coil and Cable Assembly - Maintenance Procedures 7-3
Section II	Spark Igniters - Maintenance Procedures 7-69
Section III	Ignition Exciter - Maintenance Procedures 7-85
Section IV	Main Electrical Cable Assembly - Maintenance Procedures 7-99

TABLE OF CONTENTS (Continued)

		Page
CHAPTER 8	LUBRICATION SYSTEM – MAINTENANCE INSTRUCTIONS	8-1
	Chapter Overview	8-1
Section I	Main Oil Pump and Scavenge Oil Screen - Maintenance Procedures . . .	8-7
Section II	Oil Cooler Assembly - Maintenance Procedures	8-21
Section III	Oil Temperature Transmitter - Maintenance Procedures	8-41
Section IV	Oil Filler Assembly and Oil Filler Strainer - Maintenance Procedures	8-47
Section V	Oil Filter Cap and Stem Assembly and Oil Filter Element - Maintenance Procedures	8-63
Section VI	Dual Chip Detector - Maintenance Procedures	8-73
Section VII	Oil Lines - Maintenance Procedures	8-93
Section VIII	Starter Gearbox Filter - Maintenance Procedures	8-249
Section IX	No. 2 Bearing Pressure Oil Strainer - Maintenance Procedures	8-257
Section X	No. 4 and 5 Bearing Filter - Maintenance Procedures	8-263
Section XI	Oil Drain Cock - Maintenance Procedures	8-279
Section XII	Chip Detector- Maintenance Procedures	8-287
Section XIII	Oil Level Indicator - Maintenance Procedures	8-301
Section XIV	Oil Level Float Assembly - Maintenance Procedures	8-335
CHAPTER 9	TORQUEMETER SYSTEM – MAINTENANCE INSTRUCTIONS	9-1
	Chapter Overview	9-1
Section I	Torquemeter Junction Box - Maintenance Procedures	9-3
Section II	Output Shaft - Maintenance Procedures	9-19
Section III	Torquemeter Head Assembly – Maintenance Procedures	9-39

TABLE OF CONTENTS (Continued)

	Page
APPENDIX A REFERENCES	A-1
APPENDIX B MAINTENANCE ALLOCATION CHART	B-1
APPENDIX C EXPENDABLE SUPPLIES AND MATERIALS LIST	C-1
APPENDIX D WIRING DIAGRAMS	D-1
APPENDIX E ILLUSTRATED LIST OF MANUFACTURED ITEMS	E-1
APPENDIX F ABBREVIATIONS	F-1
	GLOSSARY
	GLOSSARY-1
	SUBJECT INDEX
	INDEX-1

HOW TO USE THIS MANUAL

OVERVIEW

This information gives a general description of the entire manual and how to use it along with the repair parts and special tools list (TM 55-2840-254-23P). If you cannot find information, you cannot do the job. Learning how to use this manual can help. Check how the manual is put together and how its system works.

1. DESCRIPTION OF MANUAL

This manual has nine chapters and six appendixes. Each chapter is divided into sections. Each section in Chapter 1 is divided into paragraphs or tasks. Each section in Chapters 2 thru 9 is divided into tasks. The tasks tell you what you need and how to do any job. The paragraphs have specific information you will need to know. The appendixes have general information you will need to know. They list references, expendable supplies and materials etc.

A. Chapters. Chapters divide the manual into usable engine maintenance groups. They align with standard groupings shown in the MAC chart. Refer to Appendix B.

B. Sections. Sections divide the chapters into smaller groups. They have information about the components of parts for which the chapter is titled. They align with components shown in the MAC chart. Refer to Appendix B.

C. Paragraphs/Tasks. Paragraphs make up some of the sections in Chapter 1. They contain specific information about the engine. Tasks make up some of the sections in Chapter 1 and the sections in Chapters 2 thru 9. It is the tasks that have the information you need to do any job. The upper heading after the task number is the task name. It tells the job to be done in the task. The task heading at the top of each page specifies the task to be performed and the lowest maintenance level authorized to perform that task. Tasks to be accomplished by the Aviation Intermediate Maintenance level only will be reflected by the term (AVIM) at the end of the task heading. If the term (AVIM) is not at the end of the task heading, then either the Aviation Unit or Aviation Intermediate Maintenance (AVUM) or (AVIM) level can accomplish that task. All paragraphs and tasks are numbered. This helps you find what you need when you need it. **USE THE INDEX TO FIND THE PARAGRAPH OR TASK YOU NEED. DO NOT USE PAGE NUMBERS.** Paragraphs and tasks are numbered as follows:

(1) Two-element numbers are used as shown in the examples:



(2) The first number is the number of the chapter. The second number is the paragraph or task in that chapter. The two elements are separated by a dash.

HOW TO USE THIS MANUAL (Continued)

D. Page Numbers. Pages are numbered by order of chapters, from front to back of manual, They are used as follows:

(1) Two-element numbers are used as shown in the example:

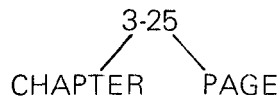

(2) The first number is the number of the chapter. The second number is the page in that chapter.

E. Initial Setup Tables. An initial setup table is the first part of every task in the manual. It lists information you will need to know before you can do the job. How to prepare the work area, what tools will be needed, and other critical information are listed when they apply. The following headings are used when they apply.

(1) Applicable Configuration. If the task does not apply to all engine configurations, different configurations covered by the same procedure will be brought to your attention.

(2) Tool. Tools, kits, or shop sets needed to do the task are listed here. If tools from your repairman's tool kit are needed, the kit is listed. Individual tools from your shop set are listed, as needed, by name, type, and size. Tools you need that are not in the kit or set, are listed by name, type, and size. Special tools and test and support equipment are listed by a T-number. Find these items in Table 1-1.

(3) Materials. This heading lists all expendable items and support materials (things you normally use up doing a job). These are things like solvent, rags, grease, safety wire, etc. They are listed by an E-number; example: Grease (E23). Find these items in Appendix C.

(4) Parts. This heading lists all mandatory replacement parts (parts you must replace if you expose or remove them during the task). These are things like gaskets, packings, cotter pins, lockwashers, etc. They are listed by RPSTL nomenclature.

(5) Personnel Required. This heading lists the people needed to do the job. They are identified by their MOS. The heading identifies the MOS and the recommended skill level to accomplish the subject task. The assigned skill level should not be construed as the only skill level authorized to accomplish that task. The Maintenance Allocation Chart (MAC) (Ref. Appendix B) assigns maintenance functions to the authorized maintenance level without regard to the MOS skill level. When more than one of any MOS is needed, the number needed is shown in parentheses. The text will tell you when the additional MOS is needed.

(6) References. This heading lists related tasks and TM's you will need to do the job. The task steps tell you when these tasks and TM's are needed.

(7) Equipment Condition. This heading lists all the things to be done before you start the job. To help, the number of the task that tells you how to do them is given when applicable.

HOW TO USE THIS MANUAL (Continued)

NOTE

All tasks covered in this manual are off helicopter tasks. If a task is an off engine task, it will be brought to your attention under "Equipment Condition." Example: "Off Engine Task. "

(8) **General Safety Instructions.** Safety precautions that must be observed when you are doing the job are described under this heading. Warnings also include basic first aid instructions.

F. **Locator Illustrations.** When needed (for removal, installation and other procedures) a locator illustration is included on or facing initial setup pages. They show you the area of the engine to be worked on. Parts involved in the task are called out.

G. **Illustration Arrows.** You will find five types of arrows used. They areas shown below:



Locator arrow used to show parts that cannot be easily seen or to indicate area of engine being worked on.



Index arrow used to identify parts on artwork.



Direction arrow used to indicate position; i.e., fwd, aft.



Movement arrow used to indicate direction of movement.



Movement arrow used to indicate direction of rotation.

H. **Procedures.** Step by step procedures tell you how to do the job. They are arranged in logical sequence to help you get the job done efficiently.

HOW TO USE THIS MANUAL (Continued)

I. Use of Clock Positions. Many procedures contain references to or views of clock positions. Comparing engine to face of clock is an easy way to locate specific engine areas. To help find clock positions on the engine, remember the following:

- (1) Clock position is always determined from rear of engine.
- (2) Once a clock position is determined from rear of engine, visualize that clock position along entire length of engine.
- (3) Hoist adapter (1) and starter drive assembly (2) are mounted at the 12-o'clock position.
- (4) Two fuel drain valves (3) are mounted at the 6-o'clock position.
- (5) Some procedures show engine mounted vertical in maintenance stand. This does not change the method for finding clock positions on the engine.

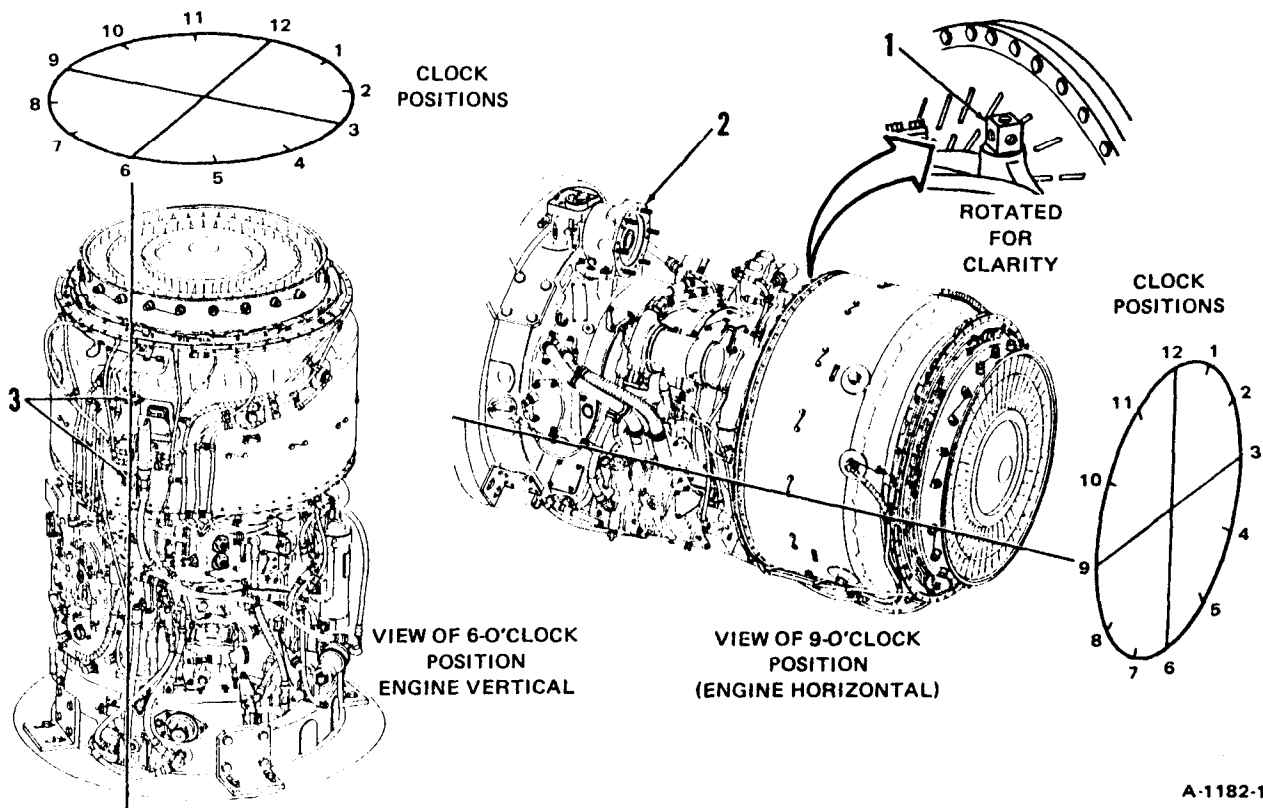

HOW TO USE THIS MANUAL (Continued)

J. Appendix A – References. This appendix lists all referenced publications needed to perform the maintenance procedures in this manual.

K. Appendix B – Maintenance Allocation Chart (MAC). This appendix consists of four sections as follows:

Section I – Introduction. This section is a summary of what is in the MAC.

Section II. This section is the MAC. The MAC assigns maintenance functions in accordance with the Three Levels of Maintenance concept for Army Aviation. The MAC has six columns, containing the following information:

Columns 1 and 2 – Functional Groups. These columns identify maintenance significant components, assemblies, subassemblies, and modules.

Column 3 – Maintenance Function. This column lists the maintenance functions to be performed on the items listed in column 2.

Column 4 – Maintenance Categories. The maintenance categories (levels) AVUM, AVIM, and DEPOT are listed with individual columns. These columns identify the maintenance level at which each maintenance function is to be performed.

Column 5 – Tools and Equipment. This column lists the reference code identifying the tool or test equipment required, as listed in Section III.

Column 6 – Remarks. Remarks identified by an alphabetical code, where applicable, are listed in Section IV and identified in column 6.

Section III – Tool and Test Equipment Requirements. This section consists of five columns, containing the following information:

Tool or Test Equipment Reference Code. This column lists the reference code listed in Column 5 – Tools and Equipment in the MAC.

Maintenance Category. This column lists the maintenance category (level) authorized to use the tool or test equipment.

Nomenclature. This column lists the nomenclature of the tools and test equipment.

National/NATO Stock Number. This column lists the stock number applicable to each tool or test equipment.

Tool Number. The tool number is listed to aid in identifying the tool or test equipment.

Section IV – Remarks. This section has two columns, containing the following information:

Reference Code. This column contains alphabetical codes or numbers in parentheses corresponding to the codes appearing in the applicable columns in the MAC.

Remarks/Notes. This column contains the actual notes cross-referenced by the reference codes to the MAC.

HOW TO USE THIS MANUAL (continued)

L. Appendix C – Expendable Supplies and Materials List. This appendix lists all expendable supplies and materials called out in the manual. The following columns are provided.

(1) Item Number. This is the E-number assigned to the expendable item. It is referred to in the detail procedures. Example: “Use cleaning solution (EI 1).”

(2) National Stock Number. This is the national stock number assigned to the item. Use it to request or requisition the item.

(3) Description. This column lists the Federal name and, if required, a description to identify the item. The last line for each item shows the part number followed by the Federal Supply Code for Manufacturer (FSCM) in parentheses, if applicable.

M. Appendix D – Wiring Diagrams. This appendix contains the engine wiring diagram. Use this appendix to help you understand the description of the engine electrical system.

N. Appendix E – Illustrated List of Manufactured Items. This appendix lists and illustrates any parts or tools you may have to make to do a job.

O. Appendix F – Abbreviations. This appendix lists abbreviations you will find in the manual.

P. Glossary. Definitions of terms you find in the manual are listed here to help you.

Q. Index. This appears at the end of the manual. It lists all subjects in the manual by alphabetical order. Items are listed as follows:

(1) Each paragraph/task number is listed with the subject it applies to:

Example:

	<u>Para./</u>	<u>Page</u>
	<u>Task</u>	
Fuel Boost Pump Assembly		
Clean	6-10	6-42
Inspect	6-11	6-43
Install	6-13	6-48
Package	6-15	6-56
Preserve	6-14	6-55
Remove	6-9	6-39
Repair	6-12	6 44

HOW TO USE THIS MANUAL (Continued)

(2) Some tasks are listed by the job to be done. The subjects or components are listed under them.

Example:

	<u>Para./ Task</u>	<u>Page</u>
Remove		
Accessory Gear Assembly (AVIM)	5-8	5-45
Accessory Gearbox Assembly	5-1	5-3
Air Diffuser Assembly (AVIM)	2-36	2-351
Anti-Icing Air Gallery Cover.	2-14	2-51

Check over the index and see how it can work for you. It can make finding information easy.

R. Part Numbers. Part numbers are not listed in this manual except where absolutely needed for clarity. You can find the part number you need in the Repair Parts and Special Tools List (RPSTL) (TM 55-2840-264-23P) .

2. HOW TO FIND WHAT YOU NEED

A. General Information (Troubleshooting).

(1) Look at the “INDEX.” Find “Symptom Index.” The “INDEX” gives the paragraph number for the symptom index. Go to the Symptom Index.

(2) Find your symptom in the “Symptom Index.” Next to the symptom is the page number of the troubleshooting procedure that will help you solve your problem. Turn to the troubleshooting procedure page.

(3) Follow the troubleshooting procedure until you find the problem. The troubleshooting procedure gives you the task number of the maintenance procedure needed to fix the engine. Turn to that task.

(4) Follow the maintenance procedure and complete all work. Check again and make sure you are right. When the job is done, recheck that the trouble has been corrected.

B. Part Numbers. To find a part number go to the RPSTL (TM 55-2840-254-23P). Find the “How To Locate Repair Parts” paragraph in the introduction. It will tell you how to find your part number.

C. Tasks To find any task, use the “INDEX.” Find the subject you want. The “INDEX” gives you the task number you want.

HOW TO USE THIS MANUAL (Continued)

3. HOW TO PREPARE FOR A TASK

Read the initial setup page carefully before starting. It tells you what you will need and what you have to know to start the job. DO NOT START A JOB UNTIL:

- You know what is needed
- You have the things you need
- You understand what to do

A. If a tool has a T-number in front of it, go to the Special Tools and Test and Support Equipment List in Table 1-1. Read down the far left-hand column to your T-number. This is the tool you need for your task.

B. If an expendable material has an E-number in front of it, go to the Expendable Supplies and Materials List in Appendix C. Read down the Item Number column to your E-number. This is the expendable you need for your task.

C. If parts are listed, they can be drawn from supply. Before you start the job, check and make sure you can get the needed parts. Part numbers are listed in TM 55-2840-254-23P.

D. Check for personnel required.

E. If preliminary procedures are listed under "Equipment Conditions," BE SURE THE LISTED JOBS ARE DONE; then do this job.

4. HOW TO DO THE JOB

Before starting, read the entire task. Familiarize yourself with the entire procedure before you begin the task. As you read, remember the following:

A. PAY ATTENTION TO WARNING, CAUTIONS AND NOTES.

B. Always follow standard maintenance practices (Chapter 1, Section XIII).

C. When values are underlined or followed by the word INSPECT, an inspector must OK the completed step.

D. Major steps and key words are printed in bold type for experienced repairers.

E. A GLOSSARY is provided. It lists the special words and terms used in this manual and gives their meaning. Use it. It may help you understand the instructions.

COMPRESSOR SECTION – MAINTENANCE INSTRUCTIONS

CHAPTER OVERVIEW

This chapter contains maintenance procedures for the compressor section. It is divided into the following sections and tasks:

<u>SECTION</u>	<u>TASK NO.</u>	<u>TITLE</u>	<u>PAGE</u>
1		INTERSTAGE AIR-BLEED ACTUATOR – MAINTENANCE PROCEDURES	
	2-1	Remove Interstate Air-Bleed Actuator	2-5
	2-2	Disassemble Interstate Air-Bleed Actuator	2-12
	2-3	Clean Interstate Air-Bleed Actuator	2-14
	2-4	Inspect Interstate Air-Bleed Actuator	2-16
	2-5	Repair Interstate Air-Bleed Actuator	2-18
	2-6	Assemble Interstate Air-Bleed Actuator	2-19
	2-7	Install Interstate Air-Bleed Actuator	2-21
	2-8	Adjust Interstate Air-Bleed Actuator	2-28
II		COMPRESSOR BLEED BAND – MAINTENANCE PROCEDURES	
	2-9	Remove Compressor Bleed Band	2-41
	2-10	Clean Compressor Bleed Band	2-44
	2-11	Inspect Compressor Bleed Band	2-45
	2-12	Repair Compressor Bleed Band	2-46
	2-13	Install Compressor Bleed Band	2-47
III		ANTI-ICING AIR GALLERY COVER – MAINTENANCE PROCEDURES	
	2-14	Remove Anti-Icing Air Gallery Cover	2-51
	2-15	Clean Anti-Icing Air Gallery Cover	2-55
	2-16	Inspect Anti-Icing Air Gallery Cover	2-58
	2-17	Repair Anti-Icing Air Gallery Cover	2-60
	2-18	Install Anti-Icing Air Gallery Cover	2-62
IV		COMPRESSOR HOUSING – MAINTENANCE PROCEDURES	
	2-19	Remove Upper Compressor Housing	2-71
	2-20	Remove Lower Compressor Housing	2-104
	2-21	Clean Compressor Housing	2-144
	2-22	Inspect Compressor Housing	2-146
	2-23	Repair Compressor Housing	2-147
	2-24	Install Upper Compressor Housing	2-149
	2-25	Install Lower Compressor Housing	2-178

<u>SECTION</u>	<u>TASK NO.</u>	<u>TITLE</u>	<u>PAGE</u>
V		STATOR VANE ASSEMBLIES – MAINTENANCE PROCEDURES	
	2-26	Remove Stator Vane Assemblies	2-219
	2-27	Clean Stator Vane Assemblies	2-228
	2-28	Inspect Stator Vane Assemblies	2-230
	2-29	Repair Stator Vane Assemblies	2-232
	2-30	Install Stator Vane Assemblies	2-234
VI		COMPRESSOR ROTOR BLADES – MAINTENANCE PROCEDURES	
	2-31	Remove Compressor Rotor Blades	2-255
	2-32	Clean Compressor Rotor Blades	2-278
	2-33	Inspect Compressor Rotor Blades	2-281
	2-34	Repair Compressor Rotor Blades	2-312
	2-35	Install Compressor Rotor Blades	2-317
VII		AIR DIFFUSER ASSEMBLY – MAINTENANCE PROCEDURES	
	2-36	Remove Air Diffuser Assembly (AVIM)	2-351
	2-37	Clean Air Diffuser Assembly (AVIM)	2-361
	2-38	Inspect Air Diffuser Assembly (AVIM)	2-363
	2-39	Repair Air Diffuser Assembly (AVIM)	2-371
	2-40	Repair Air Diffuser Assembly	2-375
	2-41	Install Air Diffuser Assembly (AVIM)	2-383
VIII		NO. 2 BEARING PACKAGE – MAINTENANCE PROCEDURES	
	2-42	Remove No. 2 Bearing Package (AVIM)	2-395
	2-43	Disassemble No. 2 Bearing Package (AVIM)	2-402
	2-44	Clean No. 2 Bearing Package (AVIM)	2-411
	2-45	Inspect No. 2 Bearing Package (AVIM)	2-414
	2-46	Assemble No. 2 Bearing Package (AVIM)	2-417
	2-47	Install No. 2 Bearing Package (AVIM)	2-427
IX		OUTPUT SHAFT SEAL AND HOUSING ASSEMBLY – MAINTENANCE PROCEDURES	
	2-48	Remove Output Shaft Seal and Housing Assembly	2-431
	2-49	Clean Output Shaft Seal and Housing Assembly	2-436
	2-50	Inspect Output Shaft Seal and Housing Assembly	2-437
	2-51	Repair Output Shaft Seal and Housing Assembly	2-438
	2-52	Install Output Shaft Seal and Housing Assembly	2-447

<u>SECTION</u>	<u>TASK NO.</u>	<u>TITLE</u>	<u>PAGE</u>
X		INLET HOUSING COVER ASSEMBLY – MAINTENANCE PROCEDURES	
	2-53	Remove Inlet Housing Cover Assembly (AVIM)	2-455
	2-54	Clean Inlet Housing Cover Assembly (AVIM)	2-458
	2-55	Inspect Inlet Housing Cover Assembly (AVIM)	2-459
	2-56	Repair Inlet Housing Cover Assembly (AVIM)	2-460
	2-57	Install Inlet Housing Cover Assembly (AVIM)	2-461
XI		OUTPUT SHAFT SUPPORT HOUSING – MAINTENANCE PROCEDURES	
	2-58	Remove Output Shaft Support Housing (AVIM)	2-465
	2-59	Disassemble Output Shaft Support Housing (AVIM)	2-470
	2-60	Clean Output Shaft Support Housing (AVIM)	2-478
	2-61	Inspect Output Shaft Support Housing (AVIM)	2-481
	2-62	Assemble Output Shaft Support Housing (AVIM)	2-484
	2-63	Install Output Shaft Support Housing (AVIM)	2-490
XII		AIR INLET HOUSING ASSEMBLY – MAINTENANCE PROCEDURES	
	2-64	Clean Air Inlet Housing Assembly	2-497
	2-65	Inspect Air Inlet Housing Assembly	2-498
	2-66	Repair Air Inlet Housing Assembly	2-499
XIII		NO. 3 BEARING PACKAGE – MAINTENANCE PROCEDURES	
	2-67	Remove No. 3 Bearing Package (AVIM)	2-501
	2-68	Disassemble No. 3 Bearing Package (AVIM)	2-506
	2-69	Clean No. 3 Bearing Package (AVIM)	2-508
	2-70	Inspect No. 3 Bearing Package (AVIM)	2-511
	2-71	Assemble No. 3 Bearing Package (AVIM)	2-513
	2-72	Install No. 3 Bearing Package (AVIM)	2-515

<u>SECTION</u>	<u>TASK NO.</u>	<u>TITLE</u>	<u>PAGE</u>
XIV	AIR LINES	–MAINTENANCE PROCEDURES	
	2-73	Remove Hose Assembly (Interstage Air-Bleed Actuator to Fuel Control)	2-525
	2-74	Install Hose Assembly (Interstate Air-Bleed Actuator to Fuel Control)	2-528
	2-75	Remove Hose Assembly (Interstate Air-Bleed Actuator to Air Diffuser Assembly)	2-532
	2-76	Install Hose Assembly (Interstate Air-Bleed Actuator to Air Diffuser Assembly)	2-534
	2-77	Remove Hose Assembly (Compressor Housing to Inlet Housing)	2-536
	2-78	Install Hose Assembly (Compressor Housing to Inlet Housing)	2-543
	2-79	Remove Hose Assembly (Air Diffuser Assembly to Fuel Control)	2-550
	2-80	Install Hose Assembly (Air Diffuser Assembly to Fuel Control)	2-553

Section I. INTERSTAGE AIR-BLEED ACTUATOR - MAINTENANCE PROCEDURES

**2-1 REMOVE INTERSTAGE AIR-BLEED ACTUATOR-MAINTENANCE PROCEDURES
P/N 2-200-071-54 INSTALLED**

2-1

INITIAL SETUP

Applicable Configurations:
All

Tools:
Powerplant Mechanic's Tool Kit,
NSN 5180-00-323-4944

Materials:
None

Personnel Required:
68B10 Aircraft Powerplant Repairer

Equipment Condition:

Oil Cooler Assembly Removed (Task 8-5)

General Safety Instructions:

WARNING

The ignition exciter stores very high and possibly fatal voltage. Use extreme care when working around ignition exciter. Serious injur could result if exciter is accidentally grounded. Do not probe inside of putpit receptacles with fingers or metal object. Discharge exciter only with insulated screwdriver. In case of shock or injury, get medical attention

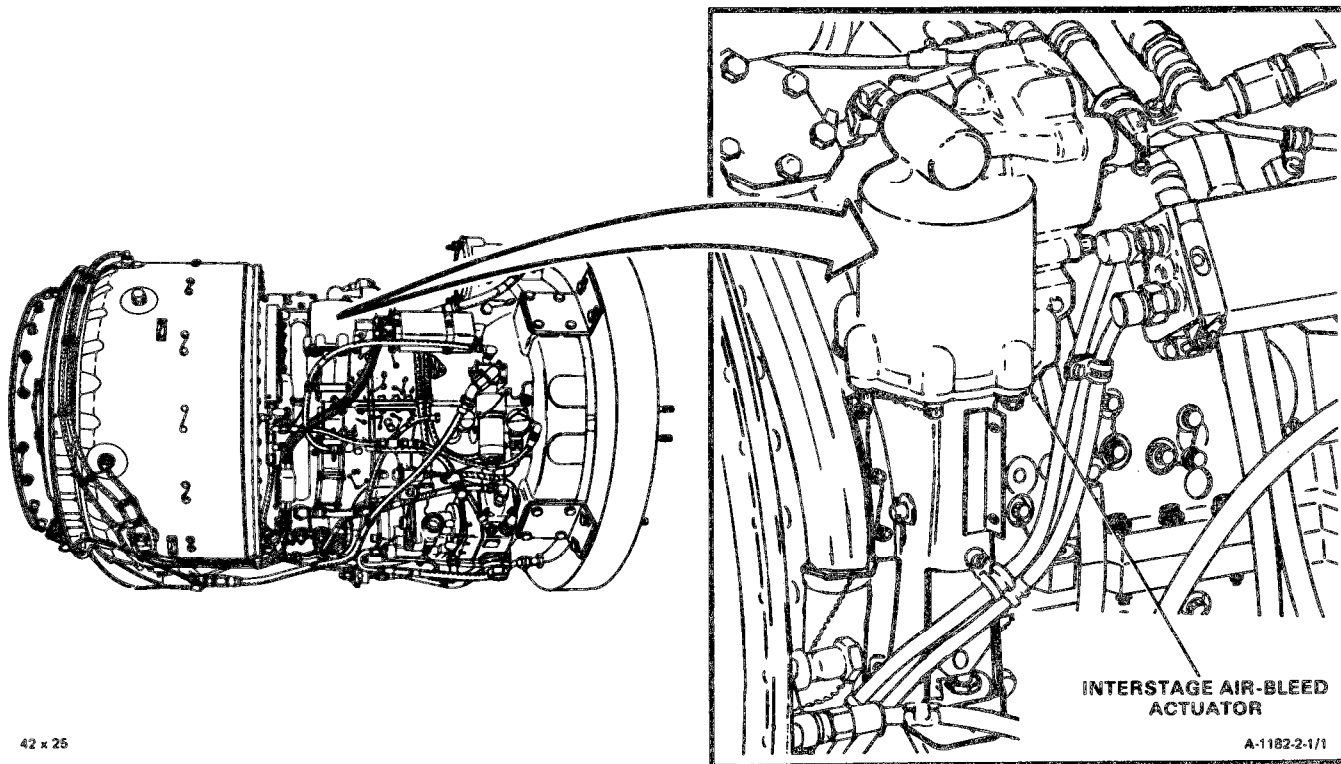

42 x 25

GO TO NEXT PAGE

WARNING

When discharging ignition exciter, remove one lead at a time and discharge receptacle that lead was removed from. Failure to do so may result in serious shock when you are removing second lead. In case of serious shock, get medical attention.

1. Remove nut (1) and screw (2).

NOTE

Steps 2. and 3. apply to both output receptacles.

2. Remove lockwire and disconnect coil and cable assembly leads (3).
3. Discharge ignition exciter (4) by placing tip of insulated screwdriver (5) against pin (6) and edge (7) of receptacle (8).
4. Place leads (3) to one side.

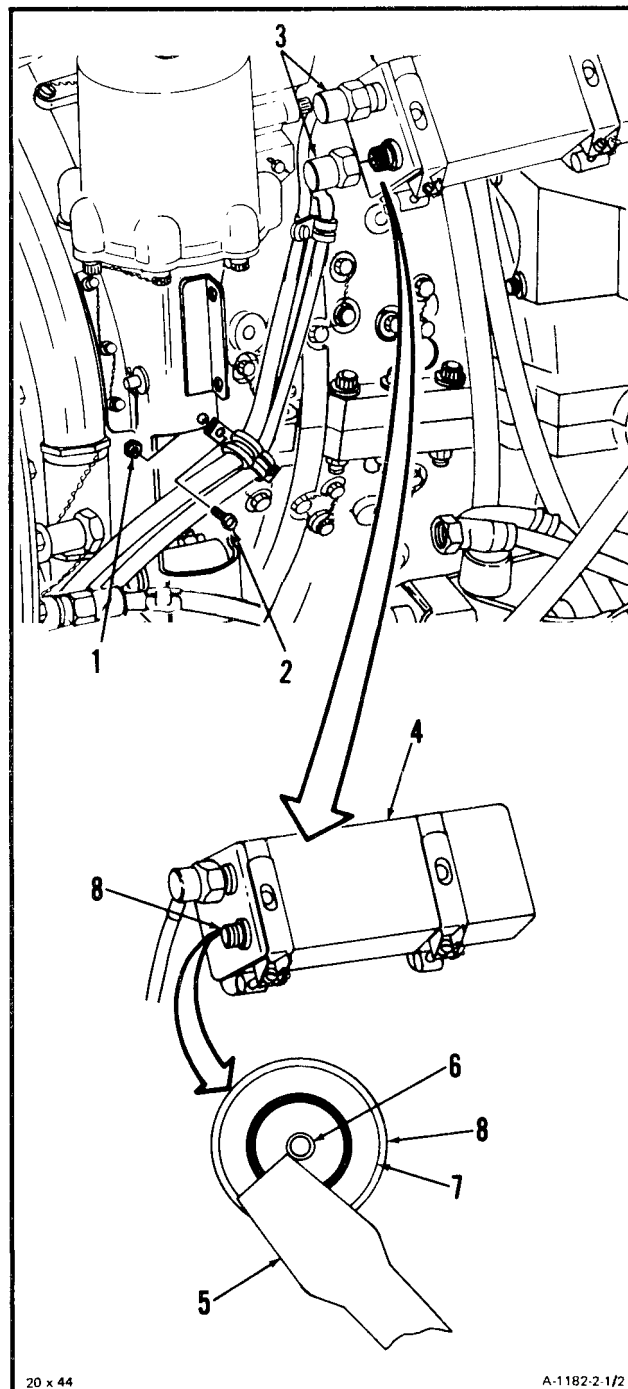

20 x 44

A-1182-2-1/2

GO TO NEXT PAGE

2-1 REMOVE INTERSTAGE AIR-BLEED ACTUATOR (WITHOUT WATER WASH KIT P/N 2-200-071-54 INSTALLED) (Continued)

2-1

5. Disconnect hose assemblies (9 and 10).

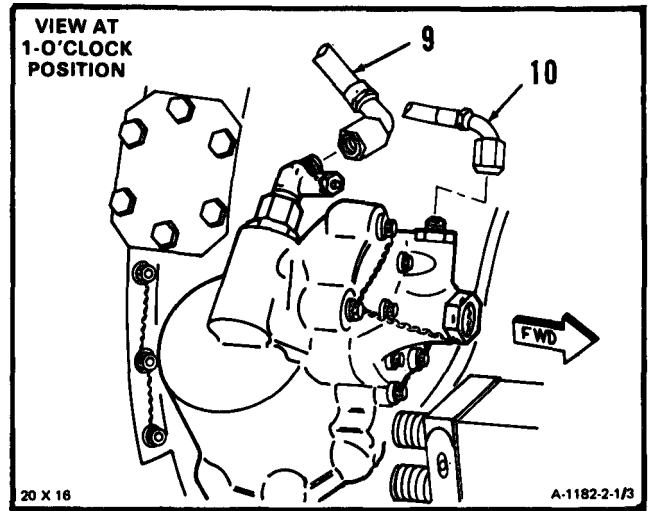

6. Disconnect and remove tee (11).

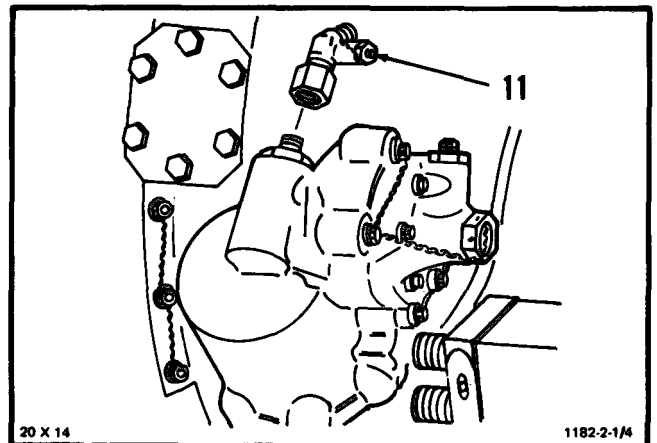

7. Remove cotter pin (12), washer (13), and pin (14).

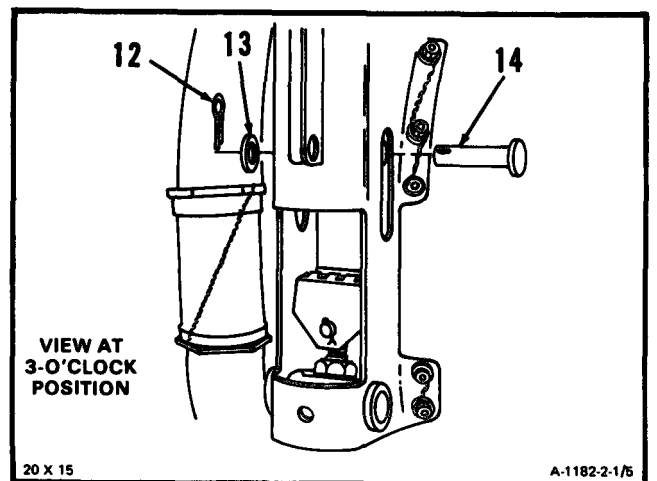

GO TO NEXT PAGE

2-1 REMOVE INTERSTAGE AIR-BLEED ACTUATOR (WITHOUT WATER WASH KIT
P/N 2-200-077-54 INSTALLED) (Continued)

8. Position piston assembly (15) so pin (16) can be seen through slot (17) in actuator bracket (18).

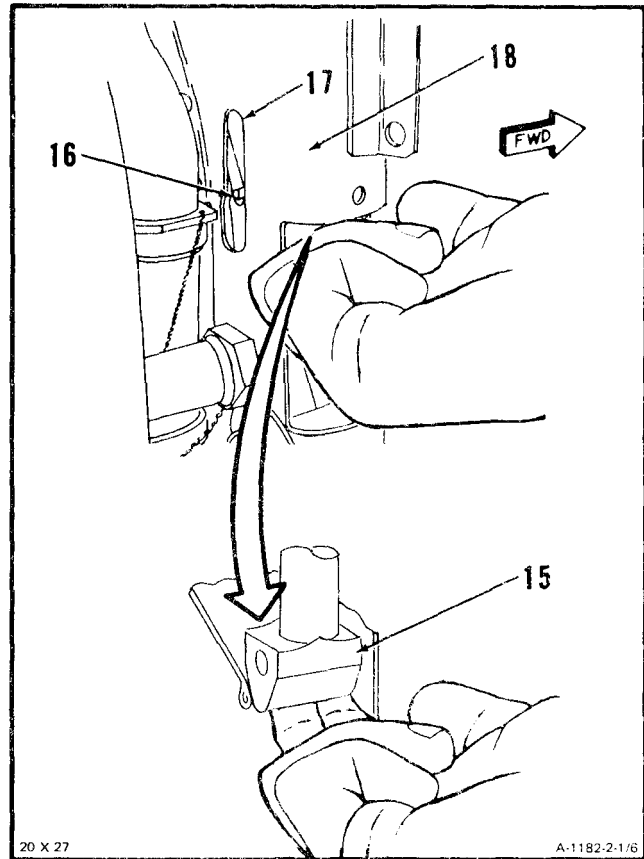

9. Push pin (16) forward as far as possible.

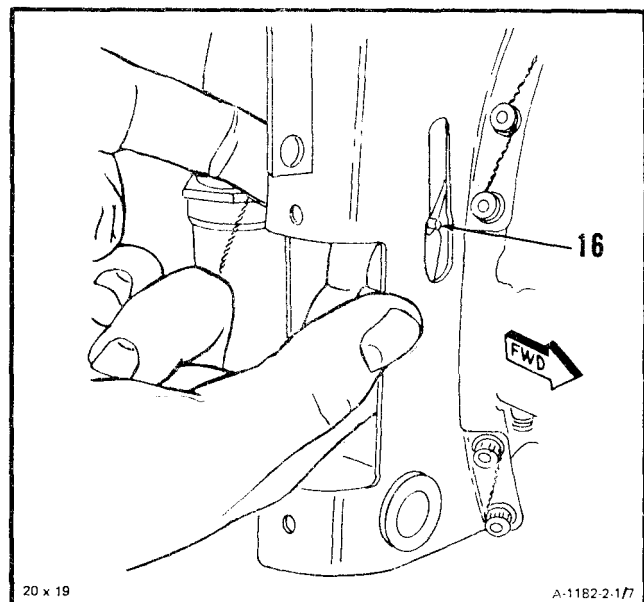

GO TO NEXT PAGE

2-1 REMOVE INTERSTAGE AIR-BLEED ACTUATOR (WITHOUT WATER WASH KIT PIN 2-200-071-54 INSTALLED) (Continued)

2-1

10. Remove pin (16)

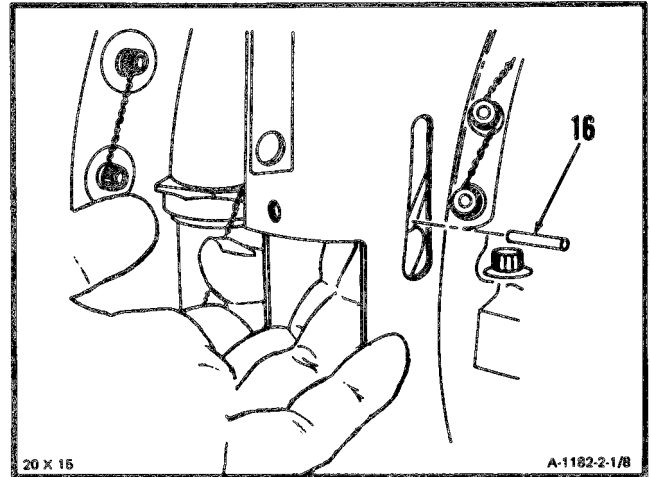

11. Pull lower yoke (19) outward, and push pin (20) forward as far as possible.

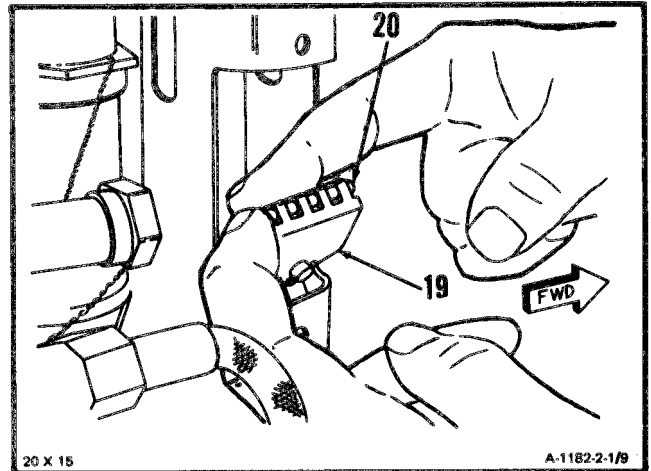

12. Remove pin (20).

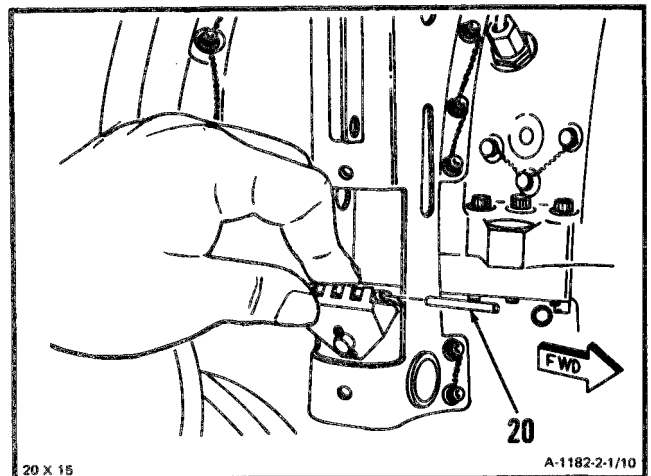

Go TO NEXT PAGE

2-1 REMOVE INTERSTAGE AIR-BLEED ACTUATOR (WITHOUT WATER WASH KIT
PIN 2-200-071-54 INSTALLED) (Continued)

13. Disconnect tube assembly (21) from union (22).

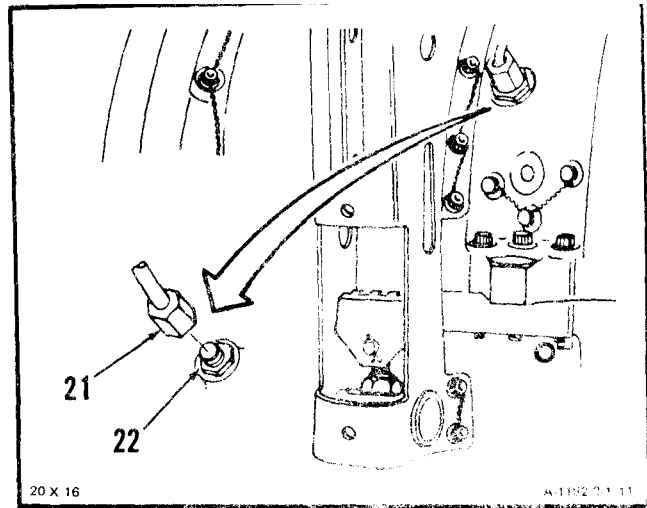

14. Remove lockwire and ten bolts (23). Remove interstage air-bleed actuator (24).

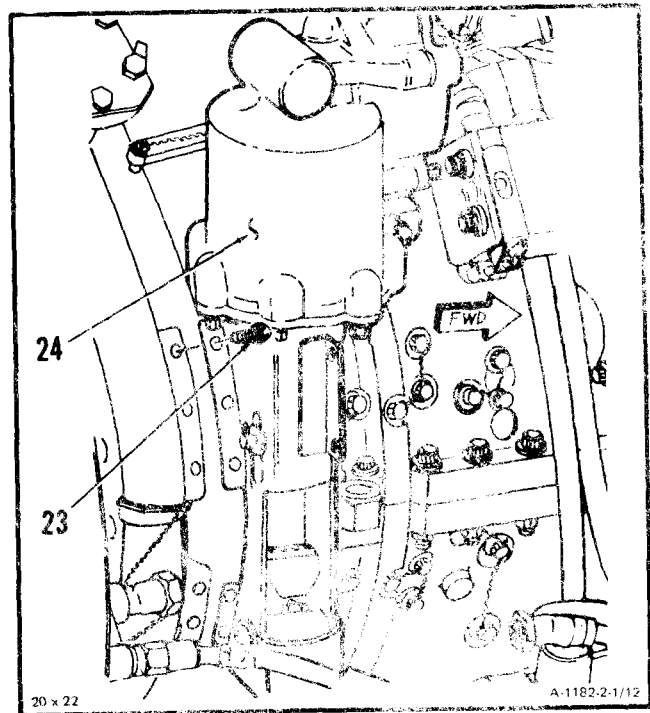

GO TO NEXT PAGE

**2-1 REMOVE INTERATAGE AIR-BLEED ACTUATOR (WITHOUT WATER WASH KIT
P/N 2-200-071 INSTALLED (CONTINUED))**

2-1

FOLLOW-ON MAINTENANCE:

None

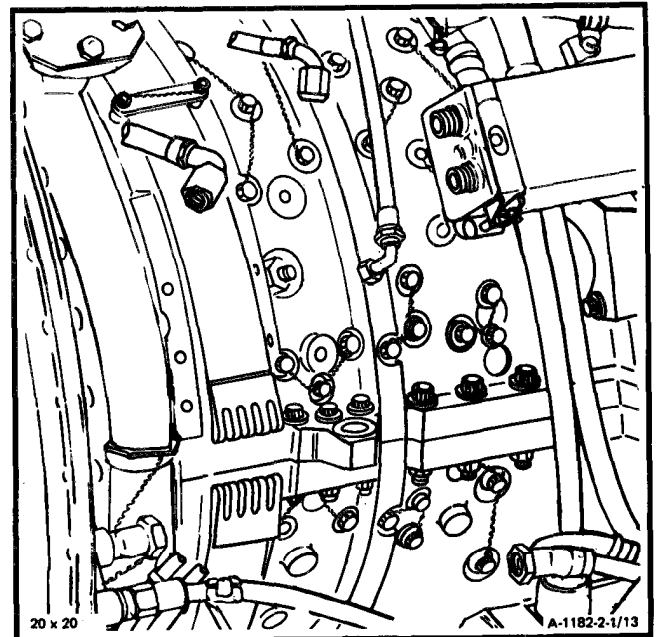
**END OF TASK**

2-1.1 REMOVE INTERSTAGE AIR-BLEED ACTUATOR WITH WATER WASH KIT
 P/N 2-200-071-54 INSTALLED)

2-1.1

INITIAL SETUP

Applicable Configurations:
 All

Tools:
 Powerplant Mechanic's Tool Kit,
 NSN 5180-00-323-4944

Materials:
 None

Personnel Required:
 68B10 Aircraft Powerplant Repairer

Equipment Condition:

Oil cooler Assembly Removed (Task 8-5)

General Safety Instructions:

WARNING

The ignition exciter stores very high and possibly fatal voltage. Use extreme care when working around ignition exciter. serious injury could result if exciter is accidentally grounded. Do not probe inside of output receptacles with fingers or metal object. Discharge exciter only with insulated screwdriver. In case of shock or injury, get medical attention.

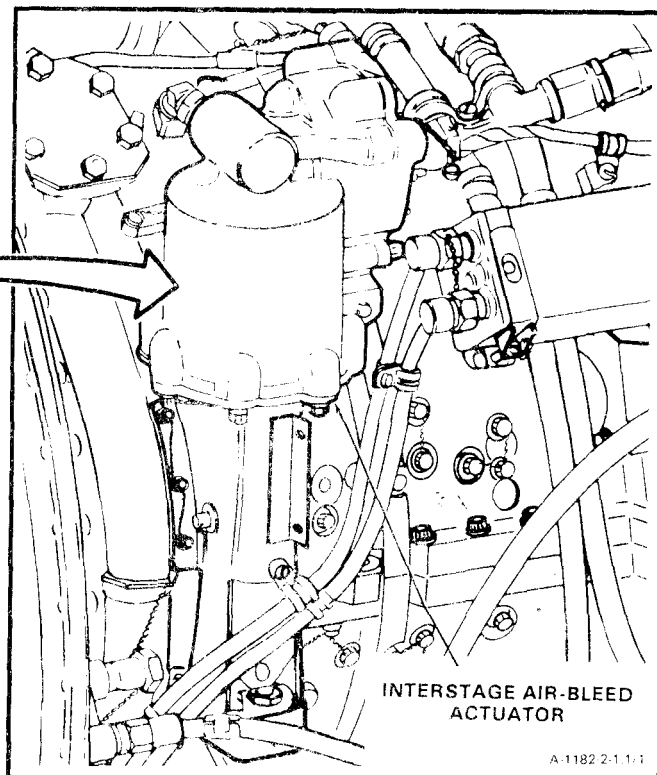
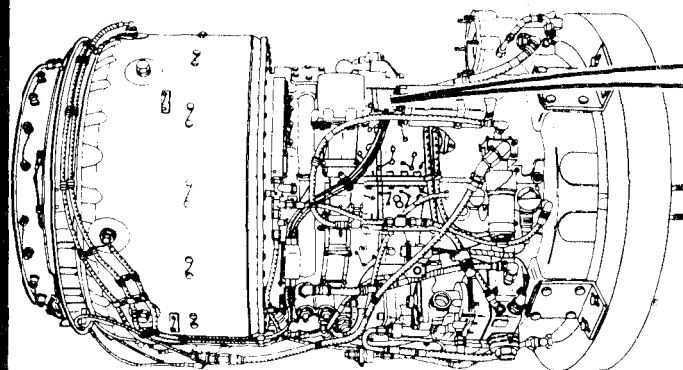

42 x 24

A-1182 2-1.1.1

GO TO NEXT PAGE

2-1.1 REMOVE INTERSTAGE AIR-BLEED ACTUATOR (WITH WATER WASH KIT P/N 2-200-071-54 INSTALLED)(Continued)

2-1.1

WARNING

When discharging ignition exciter, remove one lead at a time and discharge receptacle that lead was removed from. Failure to do so may result in serious shock when you are removing second lead. In case of serious shock, get medical attention.

1. Remove nut (1) and screw (2)

NOTE

Steps 2. and 3. apply to both output receptacles.

2. Remove lockwire and disconnect coil and cable assembly leads (3).
3. Discharge ignition exciter (4) by placing tip of insulated screwdriver (5) against pin (6) and edge (7) of receptacle (8).
4. Place leads (3) to one side.

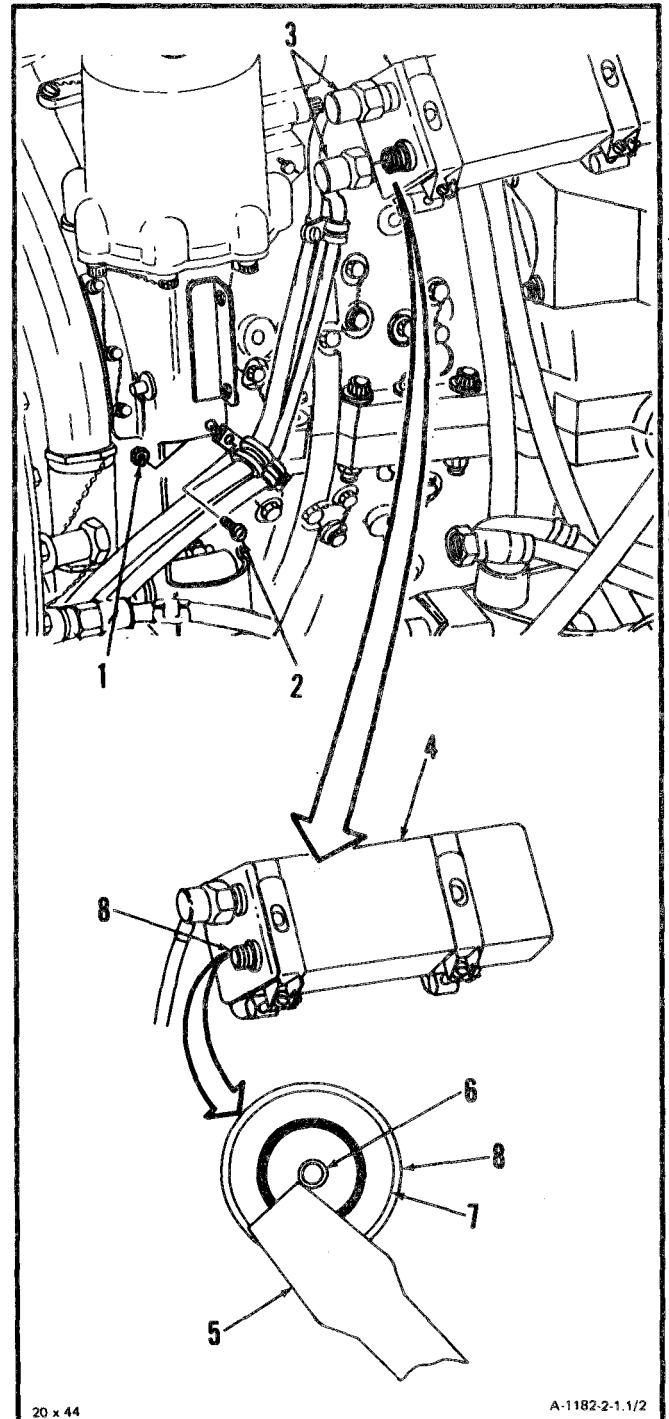

GO TO NEXT PAGE

Change 5 2-12.1

2-1.1 REMOVE INTERSTAGE AIR-BLEED ACTUATOR (WITH WATER WASH KIT P/N 2-200-071-54 INSTALLED) (Continued)

2-1.1

5. Disconnect hose assemblies (9, 10, 11 and 12).

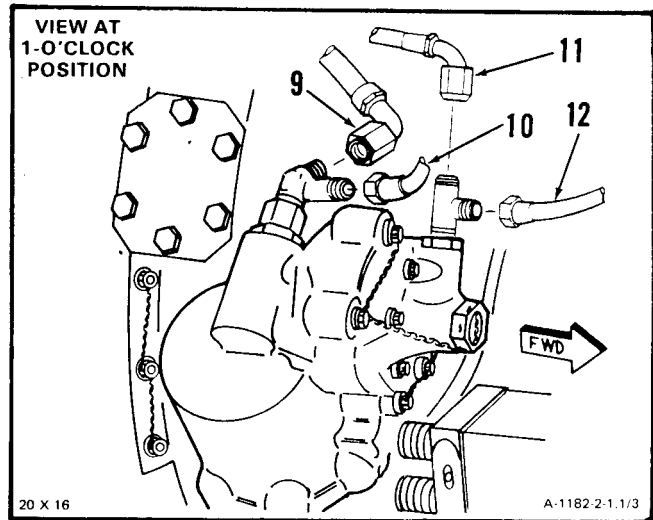

6. Disconnect and remove tee (13).

7. Disconnect and remove tee (14), nut (15), and packing (16).

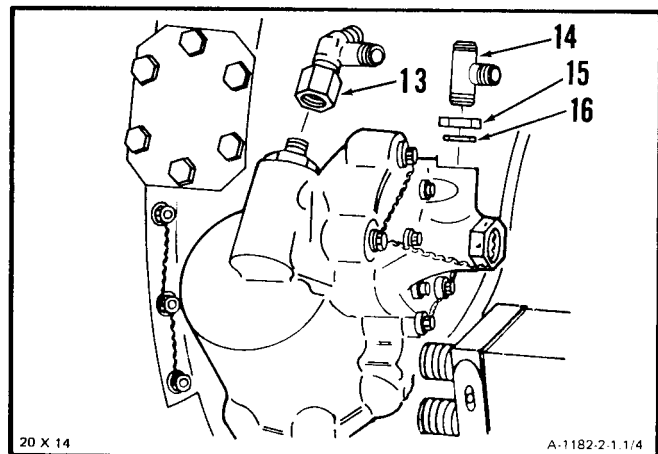

8. Remove cotter pin (17), washer (18), and pin (19).

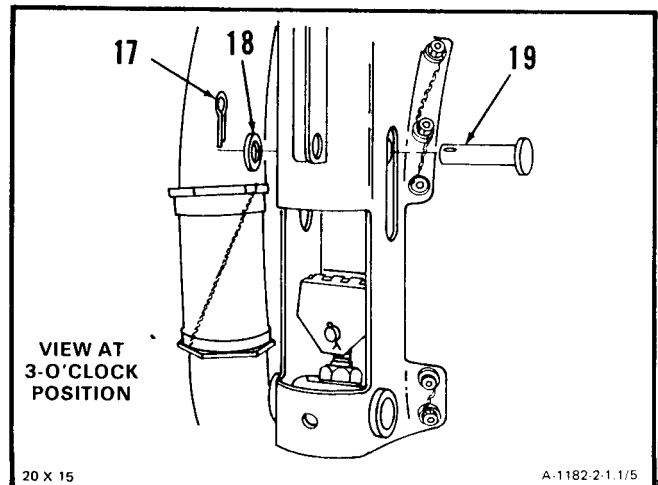

GO TO NEXT PAGE

2-1.1 REMOVE INTERSTAGE AIR-BLEED ACTUATOR (WATER WASH KIT P/N 2-200-071-54 INSTALLED) (Continued)

2-1.1

9. Position piston assembly (20) so pin (21) can be seen through slot (22) in actuator bracket (23).

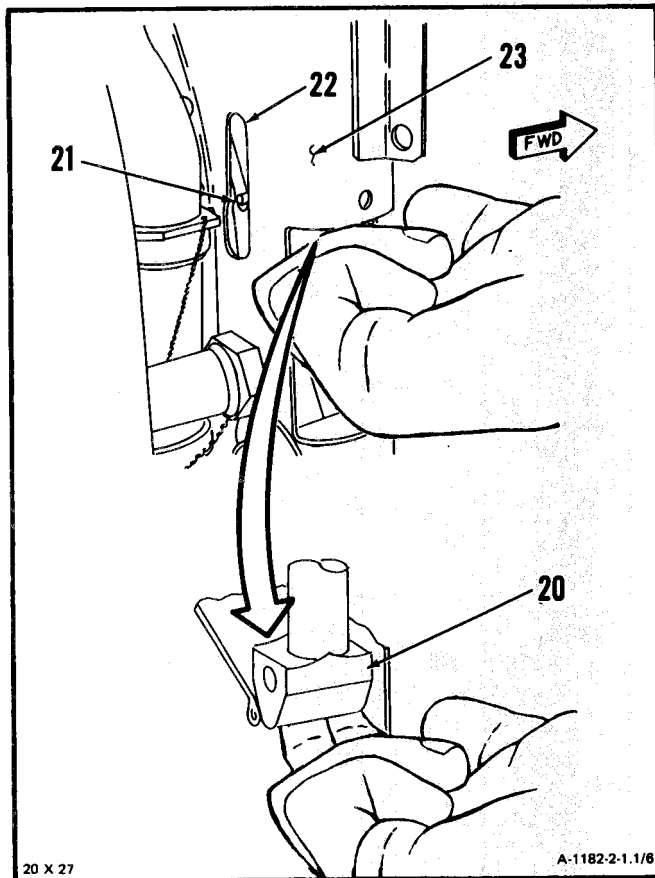

10. Push pin (21) forward as far as possible.

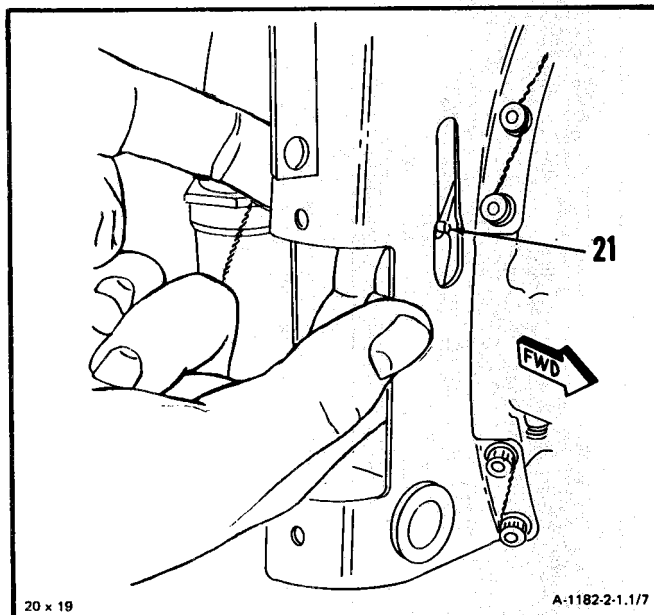

GO TO NEXT PAGE

2-1.1 REMOVE INTERSTAGE AIR-BLEED ACTUATOR (WITH WATER WASH KIT P/N 2-200-071-54 INSTALLED) (Continued)

2-1.1

11. Remove pin (21)

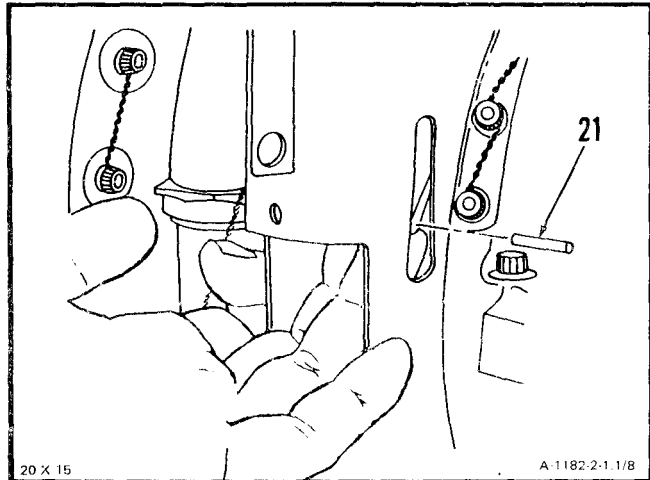

12. Pull lower yoke (24) outward, and push pin (25) forward as far as possible.

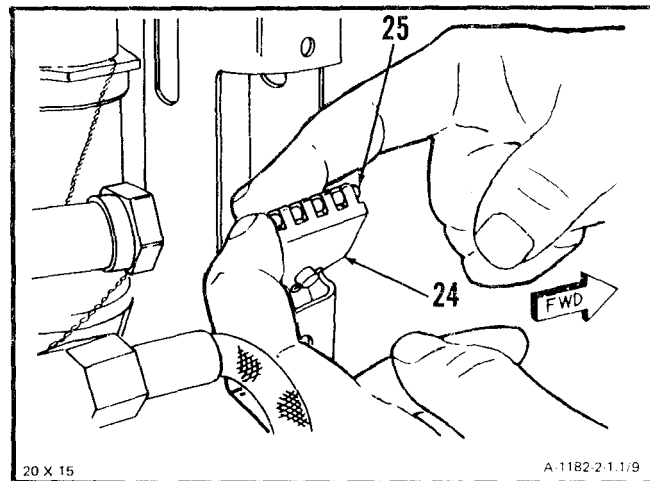

13. Remove pin (25)

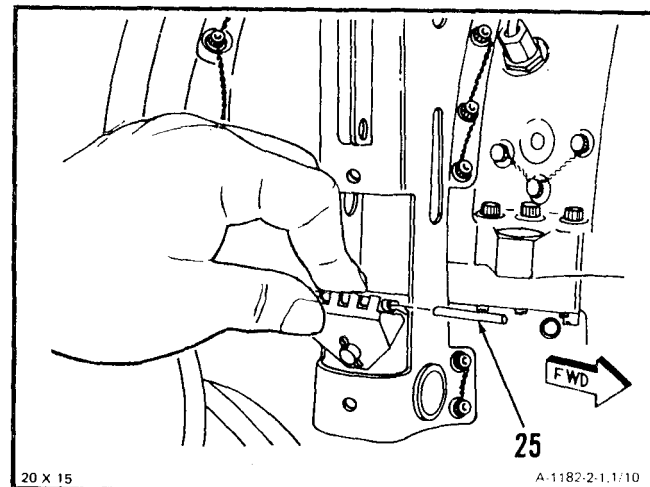

GO TO NEXT PAGE

2-1.1 REMOVE INTERSTAGE AIR-BLEED ACTUATOR (WITH WATER WASH KIT P/N 2-200-071-54 INSTALLED) (Continued)

14. Disconnect tube assembly (26) from union (27).

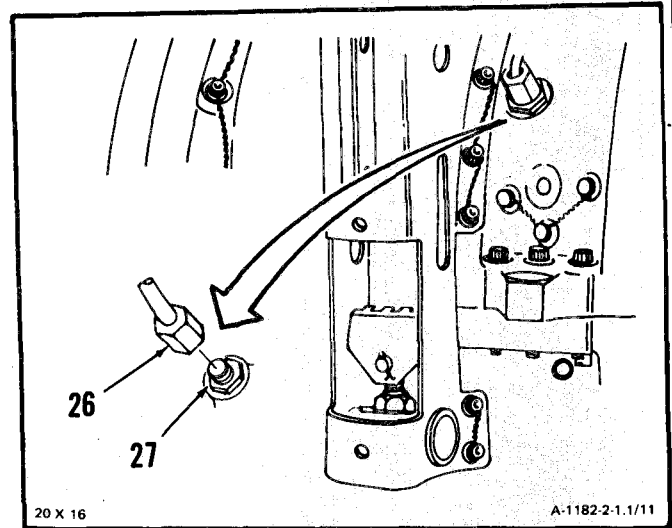

15 Remove lockwire and ten bolts (28). Remove interstage air-bleed actuator (29).

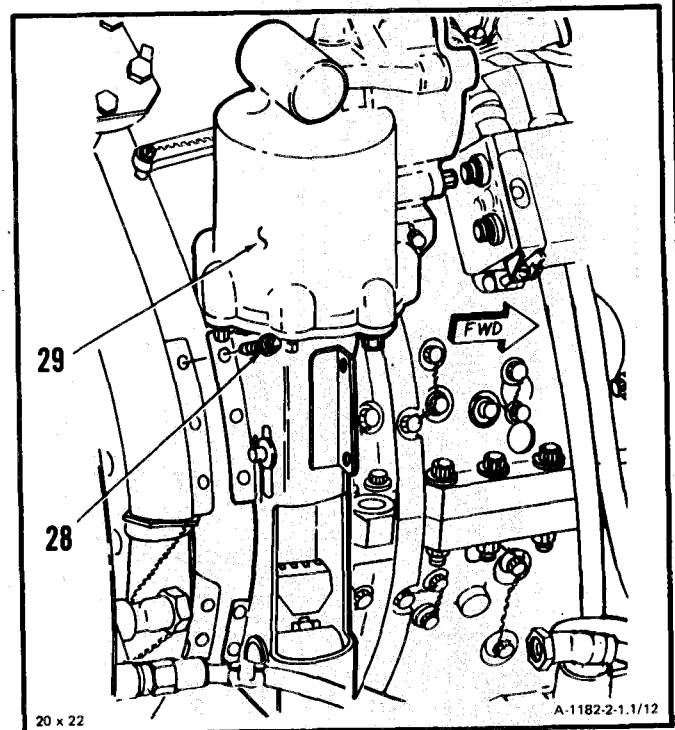

GO TO NEXT PAGE

2-1.1 REMOVE INTERSTAGE AIR-BLEED ACTUATOR (WITH WATER WASH KIT
P/N 2-200-071-54 INSTALLED) (Continued)

2-1.1

FOLLOW-ON MAINTENANCE:

None

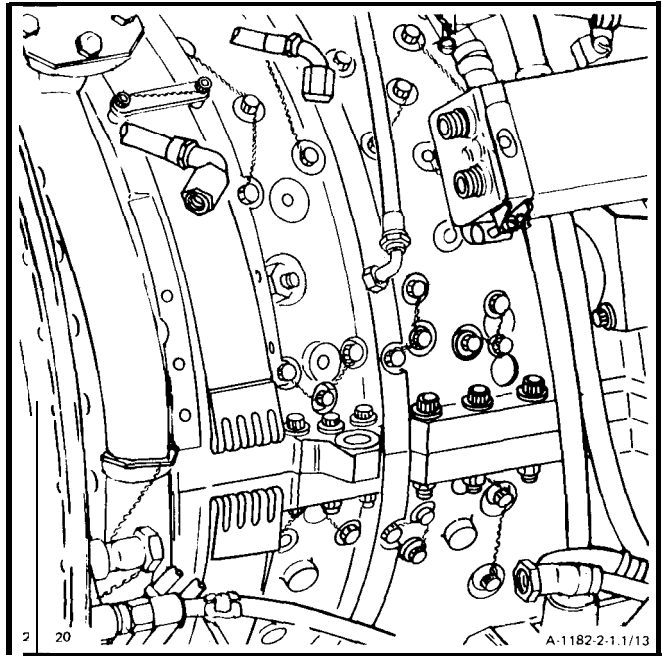

END OF TASK

2-2 DISASSEMBLE INTERSTAGE AIR-BLEED ACTUATOR

2-2**INITIAL SETUP****Applicable Configurations:**

All

Tools:

Powerplant Mechanic's Tool Kit,
NSN 5180-00-323-4944
Deep Style Socket, 1-Inch
Vise
Jaw Caps

Materials:

Crocus Cloth (EI 5)

Personnel Required:

68B10 Aircraft Powerplant Repairer

Equipment Condition:

Off Engine Task
Oil Cooler Assembly Removed (Task 8-5)
Interstage Air-Bleed Actuator Removed)
(Task 2-1)

-
1. Remove reducer (1) using vise with jaw caps and deep style socket. Remove packing (2).

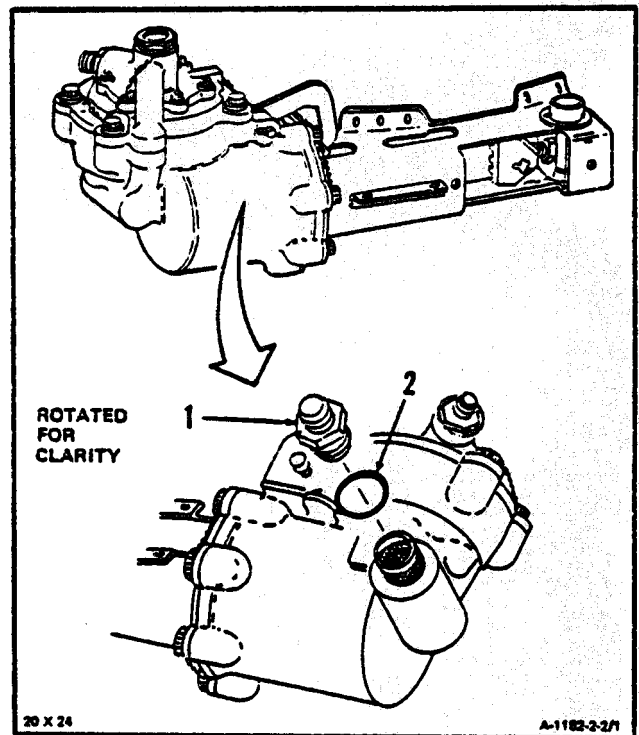

GO TO NEXT PAGE

2-2 DISASSEMBLE INTERSTAGE AIR-BLEED ACTUATOR (Continued)

2-2

2. Remove strainer element (3).

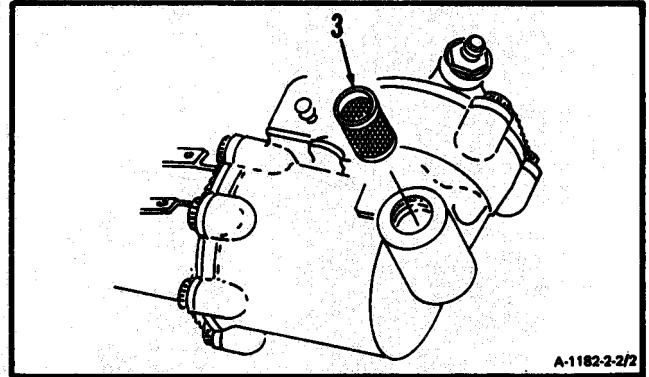

3. Remove spring (4).

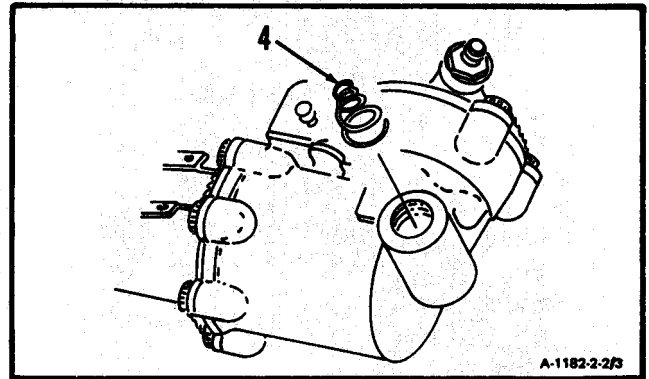

FOLLOW-ON MAINTENANCE:

None

END OF TASK

INITIAL SETUP

Applicable Configurations:

All

Tools:

Goggles

Compressed Air Source

Materials:

Dry Cleaning Solvent (E1 7)

Gloves (E20)

Lint-Free Cloth (E26)

Personnel Required:

68B10 Aircraft Powerplant Repairer

Equipment Condition:

Off Engine Task

Oil Cooler Assembly Removed (Task 8-5)

Interstage Air-Bleed Actuator Removed
(Task 2-1)

Interstage Air-Bleed Actuator Disassembled
(Task 2-2)

General Safety Instructions:



Dry cleaning solvent (E17) is flammable and toxic. It can irritate skin and cause burns. Use only in well-ventilated area, away from heat and open flame. In case of contact, immediately flush skin or eyes with water for at least 15 minutes. Get medical attention for eyes.

1. Wear gloves (E20). **Clean interstage air-bleed actuator (1)** with lint-free cloth (E26) dampened in dry cleaning solvent (E17).

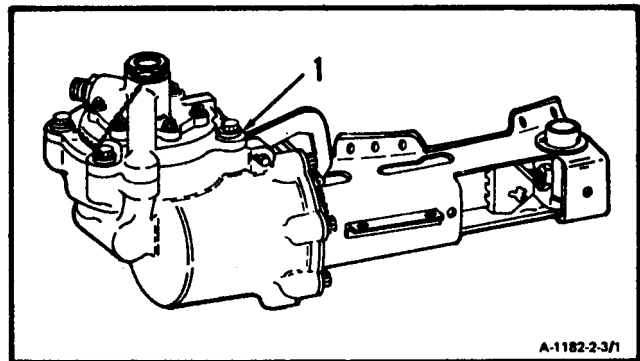

A-1182-2-3/1

GO TO NEXT PAGE

2-3 CLEAN INTERSTAGE AIR-BLEED ACTUATOR (Continued)

2-3

- Clean strainer element (2) and spring (3).
Use dry cleaning solvent (E17).

WARNING

When using compressed air for cleaning, use approved protective equipment for eye and face. Do not use more than 30 psig air pressure. Do not direct air toward yourself or another person. Failure to comply could result in injury to eyes or skin. In case of injury, get medical attention

- Wear goggles. Blow dry strainer element (2) using clean, dry compressed air.

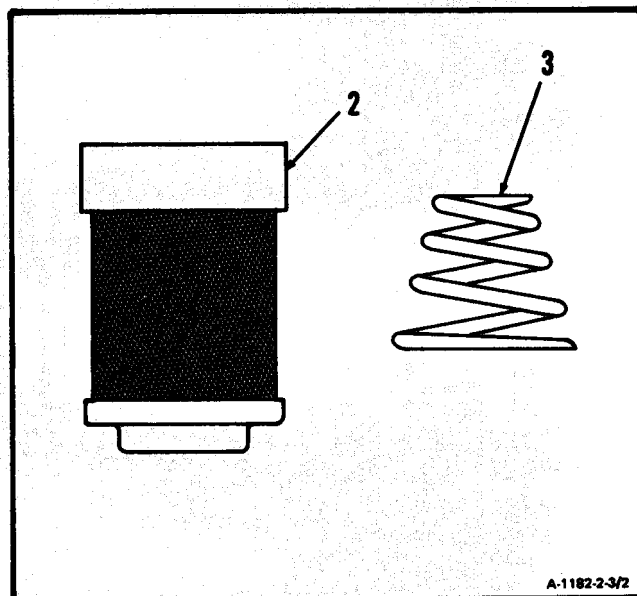
**FOLLOW-ON MAINTENANCE:**

Inspect Interstate Air-Bleed Actuator (Task 2-4).

END OF TASK

INITIAL SETUP

Personnel Required:

68B30 Aircraft Powerplant Inspector

Applicable Configurations:

All

Equipment Condition:

Off Engine Task

Tools:

Technical Inspection Tool Kit,
NSN 5180-00-323-5114

Materials:

None

1. **Inspect strainer element (1).** There shall be no tears, punctures, or broken wires in screen.

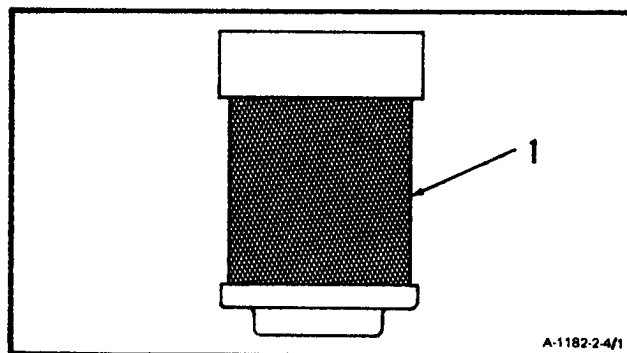

2. **Inspect spring (2).** There shall be no broken coils.

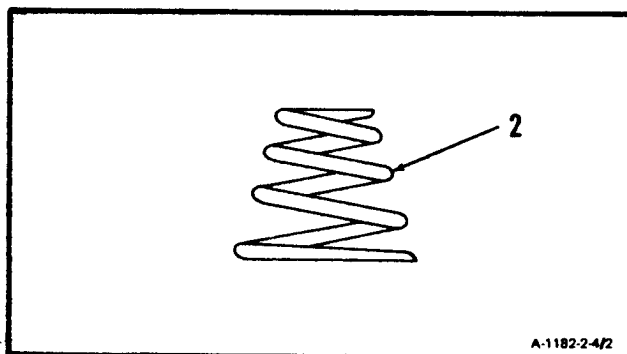

GO TO NEXT PAGE

2-4 INSPECT INTERSTAGE AIR-BLEED ACTUATOR (Continued)

2-4

3. Inspect interstage air-bleed actuator as follows:

a. Inspect bracket (3).

(1) There shall be no more than one crack in the gusset support area (4) of the uppermost holes less than 0.500 inch in length that is acceptable without stop drilling. one crack that exceeds 0.500 inch in length is allowed providing it is stop drill repaired.

(2) There shall be no sharp corners or protrusions which result from tears or gouges.

(3) There shall be no bending.

b. Inspect housing (5) and cover (6). There shall be no cracks.

FOLLOW-ON MAINTENANCE:

None

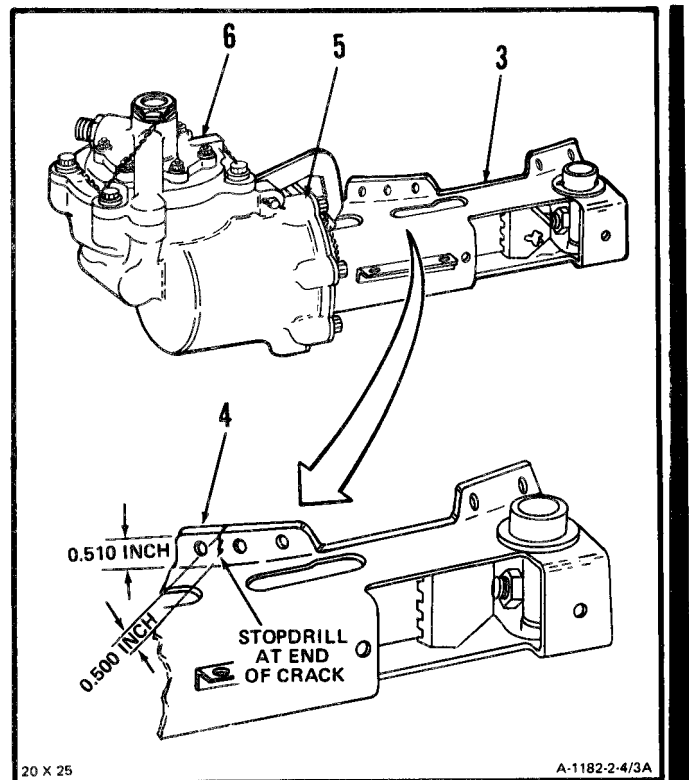

END OF TASK

2-5 REPAIR INTERSTAGE AIR-BLEED ACTUATOR

2-5**INITIAL SETUP***Applicable Configurations:*

All

*Tools:*Powerplant Mechanic's Tool Kit,
NSN 5180-00-323-4944Technical Inspection Tool Kit,
NSN 5180-00-323-5114

Hand File Set

Portable Electric Drill

Drill Bit, 3/32-inch

Drill Bit, 1/8 inch

Materials:

Crocus Cloth (E 5)

Personnel Required:

68B10 Aircraft Powerplant Repairer

68B30 Aircraft Powerplant Inspector

Equipment Condition:

Off Engine Task

1. Remove sharp comers or protrusions from tears or gouges in bracket (1) as follows:

NOTE

This repair is allowed as long as it does not change original shape of existing holes or slots.

- a. Blend-repair using file.
 - b. Polish repaired area. Use crocus cloth (E 15).
2. Straighten bends in bracket (1).

NOTE

This repair is allowed as long as it does not generate cracks or affect actuator operation.

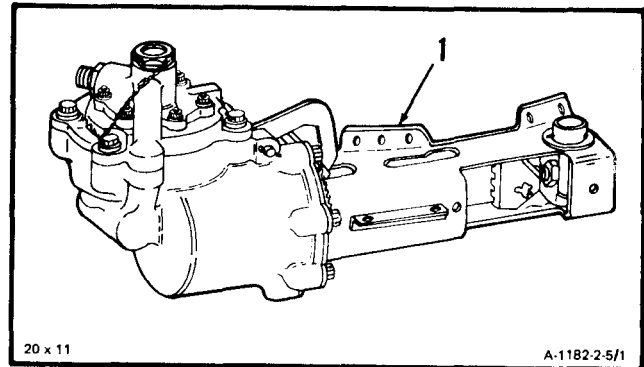
**GO TO NEXT PAGE**

2-5 REPAIR INTERSTAGE AIR-BLEED ACTUATOR (Continued)

2-5

3. Repair one crack (2) gusset support area, adjacent to the uppermost bolt holes (3).

- a. Stop drill crack (2) using portable electrical drill and a 3/32 inch drill bit.
- b. Remove burrs on each side of stop drilled hole using 1/8 inch drill bit.

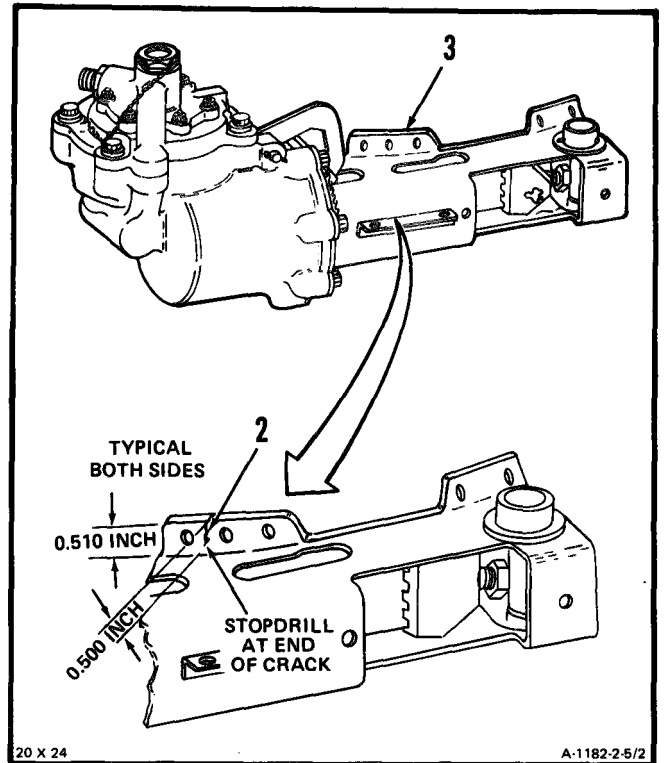

INSPECT

FOLLOW-ON MAINTENANCE:

None

END OF TASK

2-6 ASSEMBLE INTERSTAGE AIR-BLEED ACTUATOR

2-6

INITIAL SETUP**Applicable Configuration:**

All

Tools:

Powerplant Mechanic's Tool Kit,
NSN 5180-00-323-4944
Technical inspection Tool Kit,
NSN 5180-00-323-5114
Deep Style Socket, 1-Inch

Materials:

None

Parts:

Packing

Personnel Required:

68B10 Aircraft Powerplant Repairer
68B30 Aircraft Powerplant Inspector

References:

TM 55-2840-254-23P

Equipment Condition:

Off Engine Task

-
1. Install spring (1), large end down.

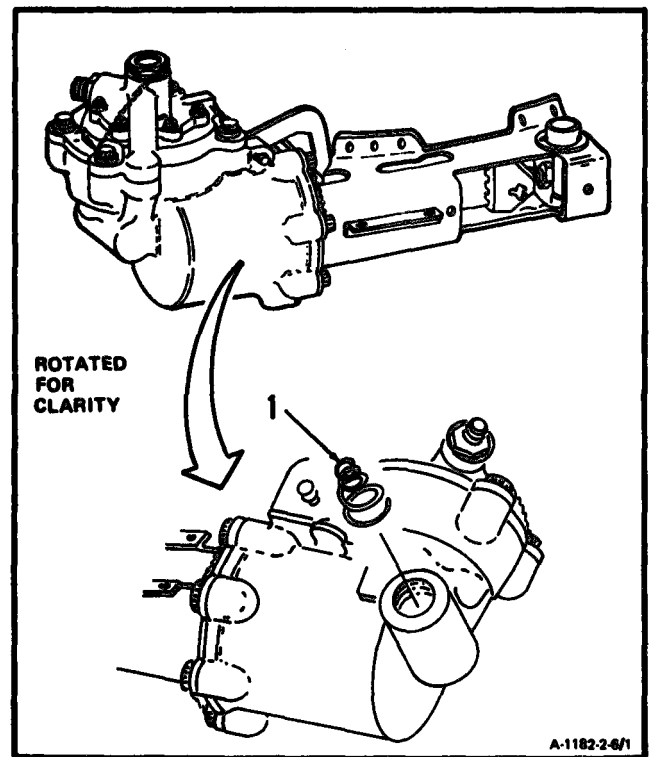

GO TO NEXT PAGE

2-6 ASSEMBLE INTERSTAGE AIR-BLEED ACTUATOR (Continued)

2-6

2. Install strainer element (2), open end up.

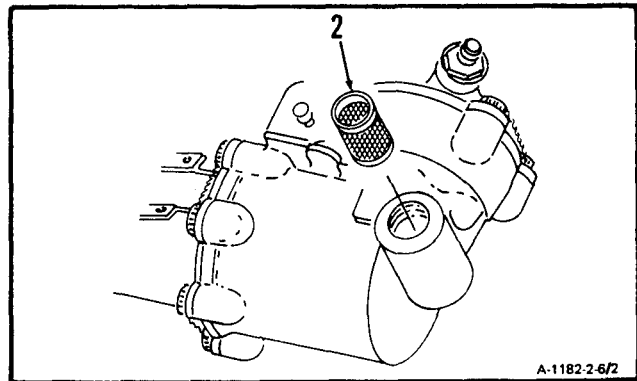

3. Install packing (3) and reducer (4). Use deep style socket,

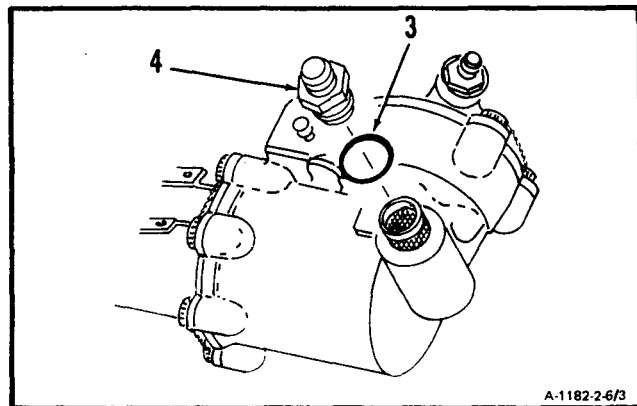

INSPECT

FOLLOW-ON MAINTENANCE:

None

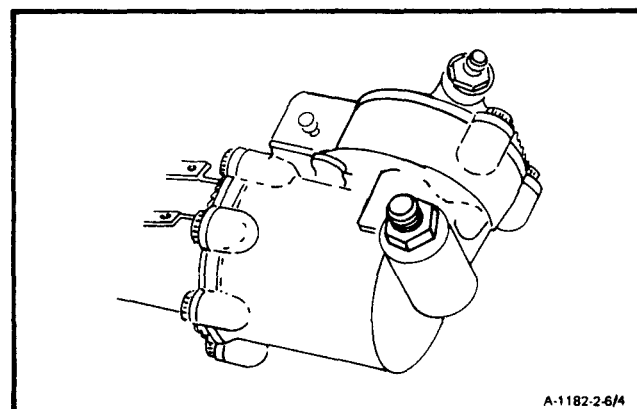

END OF TASK

2-7 INSTALL INTERSTAGE AIR-BLEED ACTUATOR (WITHOUT WATER WASH KIT
P/N 2-200-071-54 INSTALLED)

2-7

INITIAL SETUP

Applicable Configurations

All

Tools:

- Powerplant Mechanic's Tool Kit,
NSN 5180-00-323-4944
- Technical Inspection Tool Kit,
NSN 5180-00-323-5114
- Torque Wrench, 0-30 Inch-Pounds
- Torque Wrench, 30-150 Inch-Pounds

Materials:

- Lockwire (E29)

Parts:

- Cotter Pin

Personnel Required;;

- 68B10 Aircraft Powerplant Repairer
- 68B10 Aircraft Powerplant Inspector

References:

- TM 55-2840-254-23P
- Task 2-8

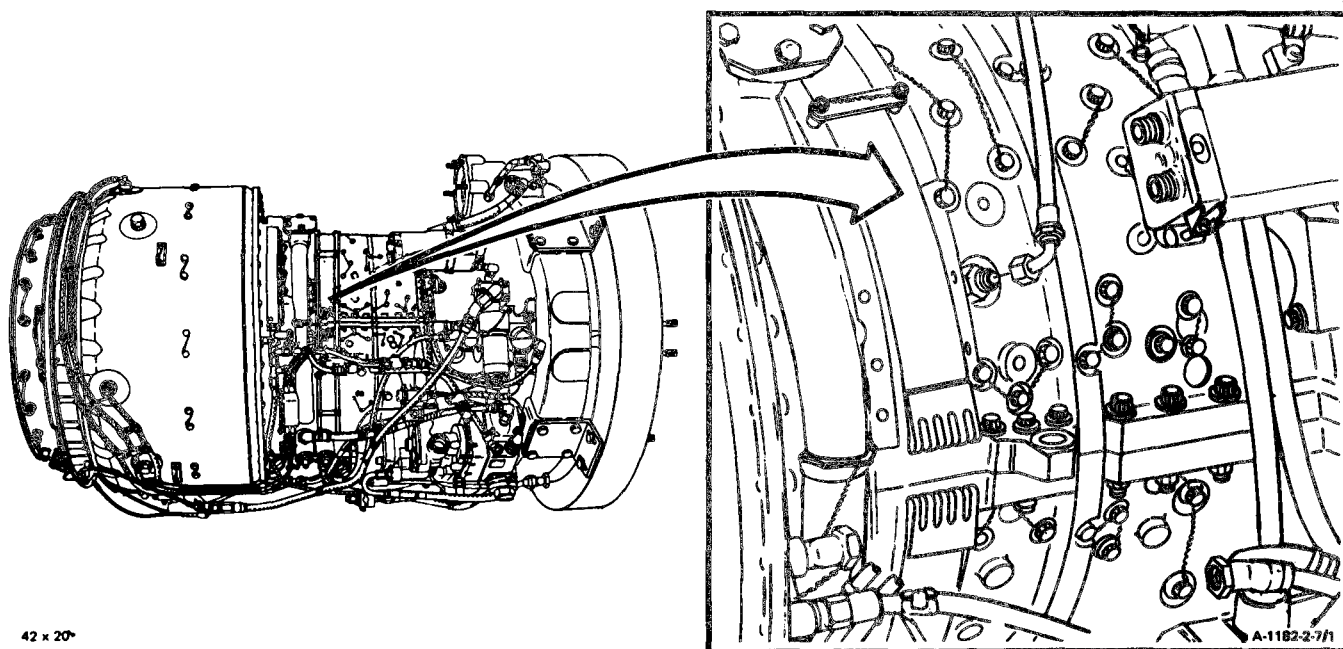

GO TO NEXT PAGE

2-7 INSTALL INTERSTAGE AIR-BLEED ACTUATOR WITHOUT WATER WASHKIT
 P/N 2-200-071-54 INSTALLED) (Continued)

1. Install interstate air-bleed actuator (1) over ends of bleed band (2) and on compressor housing (3).

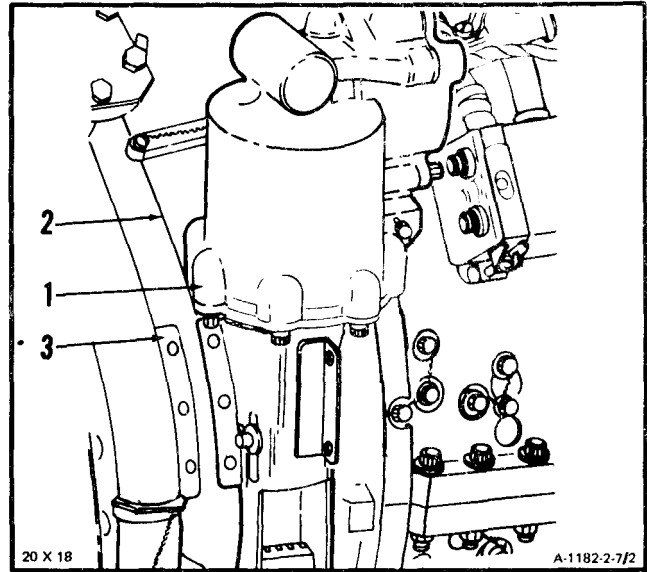

2. Position bleed band (2) and interlock bleed band upper end (4) with tangs on piston assembly (5).

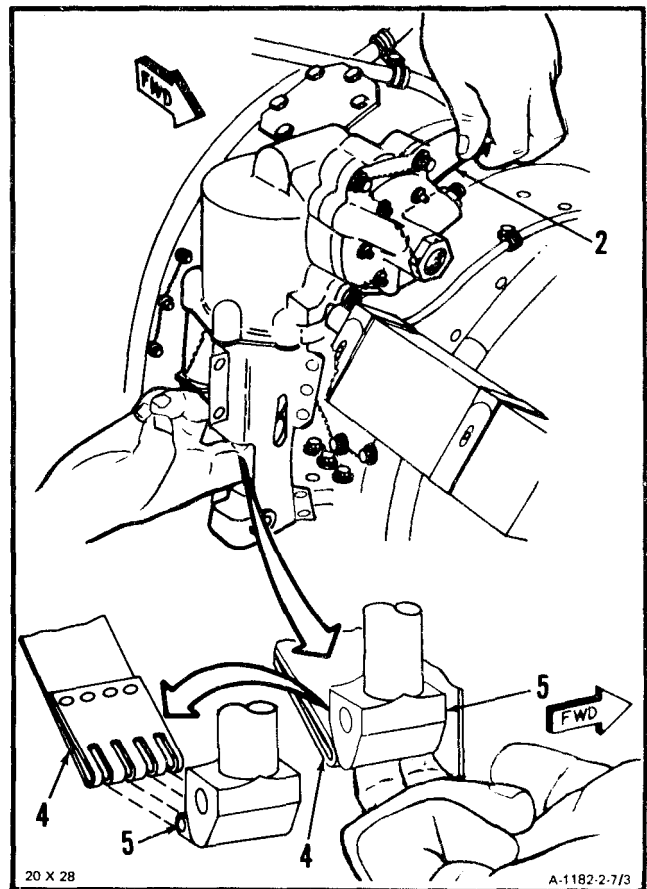

GO TO NEXT PAGE

2-7 INSTALL INTERSTAGE AIR-BLEED ACTUATOR (WITHOUT WATER WASH KIT P/N 2-200-071-54 INSTALLED) **(Continued)**

2-7

3. Hold interlock parts together and position them so bleed band upper end (4) is seen through slot (69.) install pin (7).

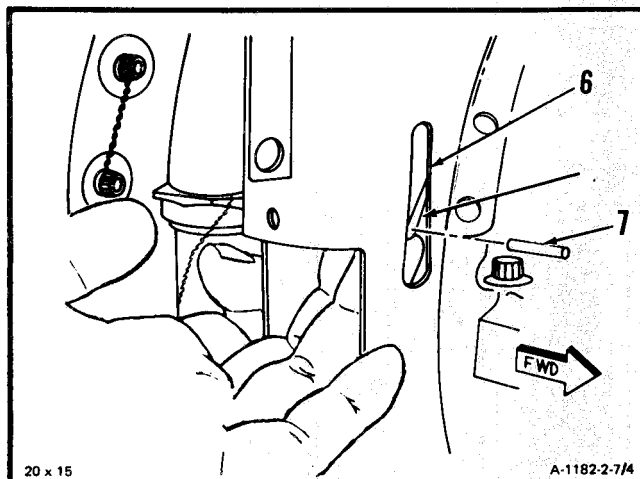

4. Interlock bleed band lower end (8) and tangs of yoke (9). Hold interlocked parts together and position them out of bracket (10). Install pin (11).

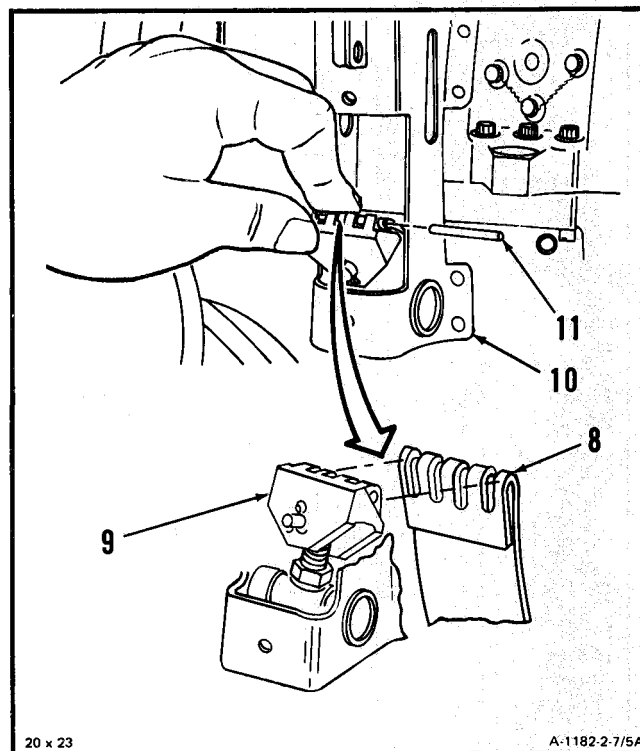

GO TO NEXT PAGE

2-7 INSTALL INTERSTAGE AIR-BLEED ACTUATOR (WITHOUT WATER WASH KIT
P/N 2-200-071-54 INSTALLED) (Continued)

- Position piston assembly (5) so hole (12) can be seen through slot (6). Install pin (13), washer (14), and cotter pin (15).

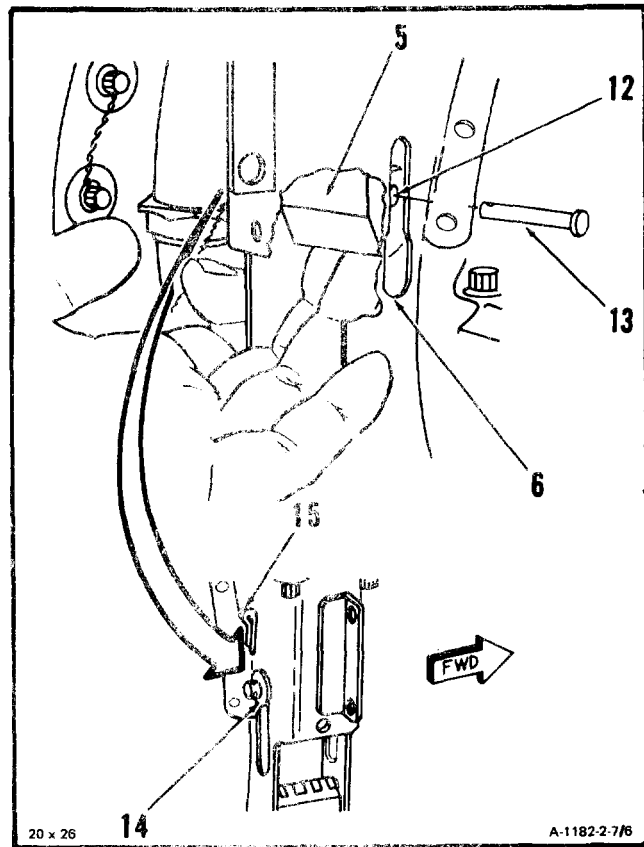

- Install on compressor housing. Secure with two bolts (16) and eight bolts (17). Torque two top bolts (16) to ten inch-pounds, Torque remaining eight bolts (17) in pairs, 180 degrees apart, in rotation to 20 inch-pounds initial torque. Retorque same eight bolts (17) in same sequence to 35 to 40 inch-pounds. Lockwire ten bolts (16 and 17). Use lockwire (E29).

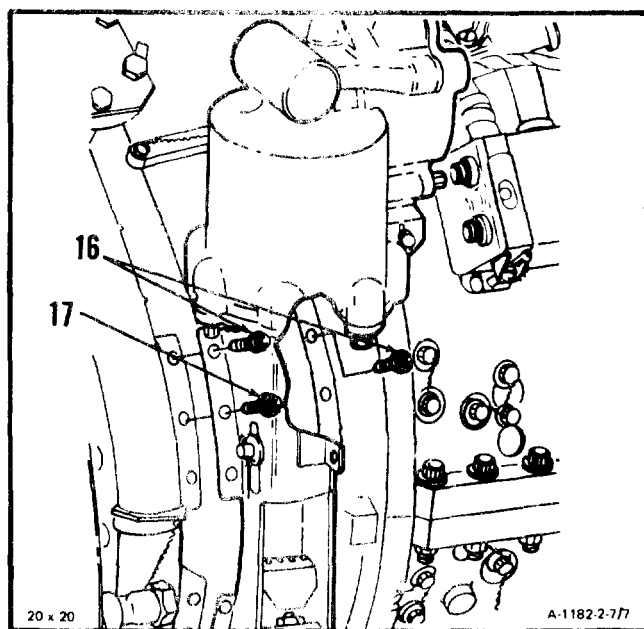

GO TO NEXT PAGE

2-7 INSTALL INTERSTAGE AIR-BLEED ACTUATOR (WITHOUT WATER WASH KIT PIN 2-200-071-54 INSTALLED) (Continued)

2-7

7. Connect tube assembly(18) to union (19).

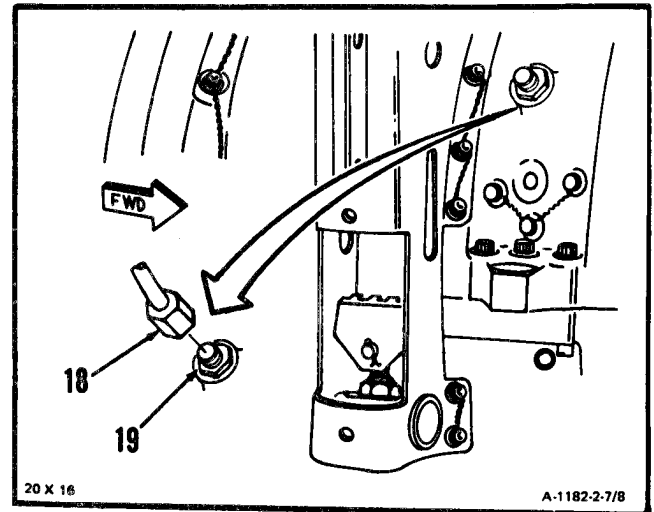

8. Install tee (20) on reducer (21).

9. Adjust interstate air-bleed actuator (Ref. Task 2-8, steps 6. thru 17.)

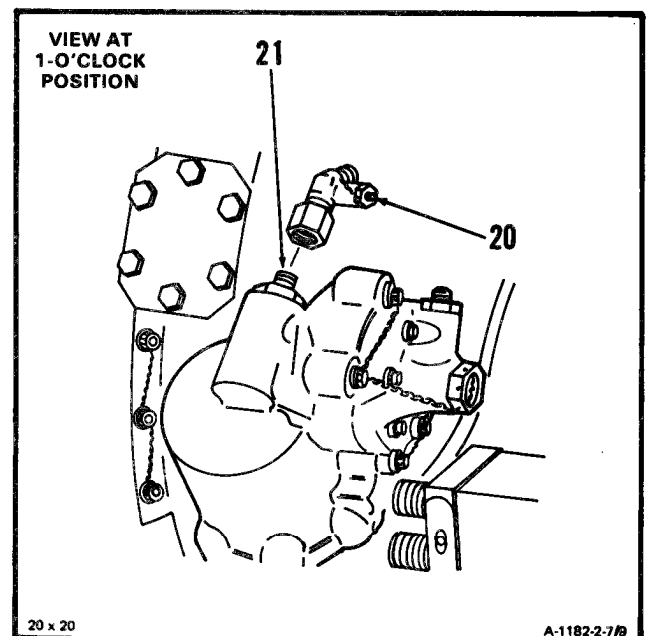

GO TO NEXT PAGE

2-7 INSTALL INTERSTAGE AIR-BLEED ACTUATOR (WITHOUT WATER WASH KIT P/N 2-200-071-54 INSTALLED) (Continued)

- 10. Connect hose assembly (22) to union (23).
- 11. Connect hose assembly (24) to tee (20).

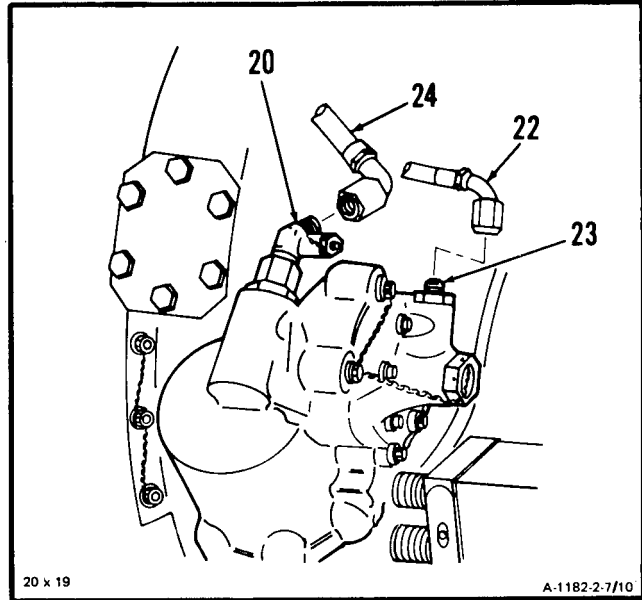

- 12. Connect two coil and cable assembly leads (25) to ignition exciter output receptacles (26). LockWire leads. Use lockwire (E29).
- 13. Install screw (27) and nut (28).

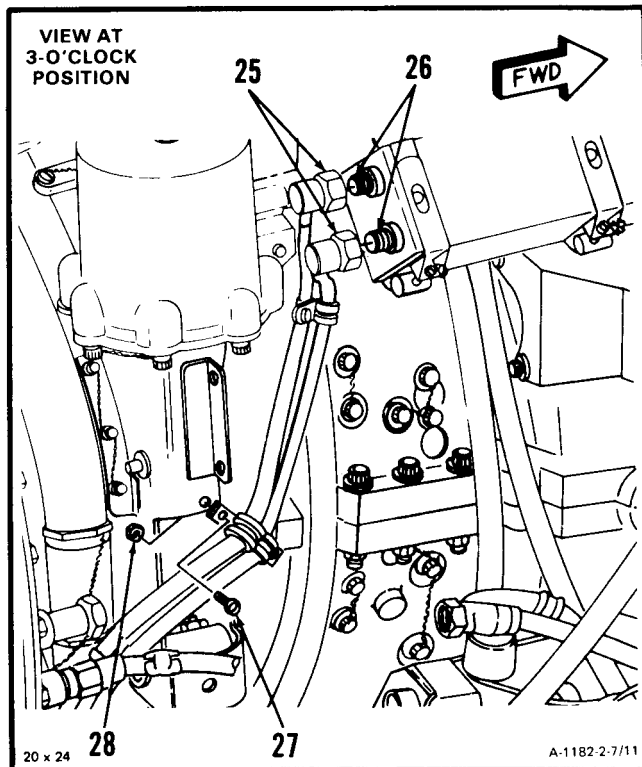

INSPECT

GO TO NEXT PAGE

**2-7 INSTALL INTERSTAGE AIR-BLEED ACTUATOR (WITHOUT WATER WASH KIT
P/N 2-200-071-54 INSTALLED) (Continued)**

2-7

FOLLOW-ON MAINTENANCE:

Install Oil Cooler Assembly (Task 8-11).

Perform Bleed Band Closure Check (Task 1-107).

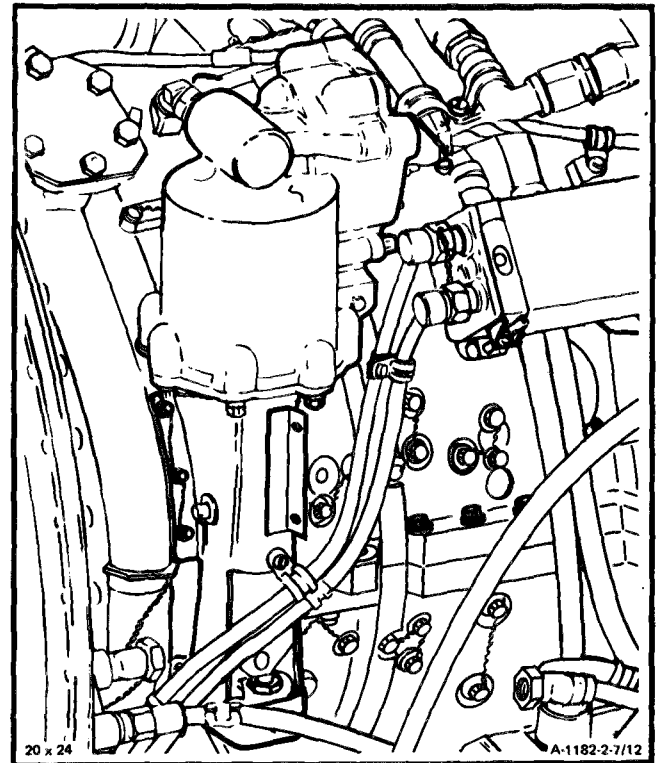
**END OF TASK****Change 5 2-27**

2-7.1 INSTALL INTERSTAGE AIR-BLEED ACTUATOR (WITH WATER WASH KIT
P/N 2-200-071-54 INSTALLED)

2-7.1

INITIAL SETUP

Applicable Configurations:

All

Tools:

- Powerplant Mechanic's Tool Kit,
NSN 5180-00-323-4944
- Technical Inspection Tool Kit,
NSN 5180-00-3235114
- Torque Wrench, 0-30 Inch-Pounds
- Torque Wrench, 30-150 Inch-Pounds

Materials:

Lockwire (E29)

Parts:

Cotter Pin

Personnel Required:

- 68B10 Aircraft Powerplant Repairer
- 68B30 Aircraft Powerplant Inspector

References:

- TM 55-2840-254-23P
- Task 2-8

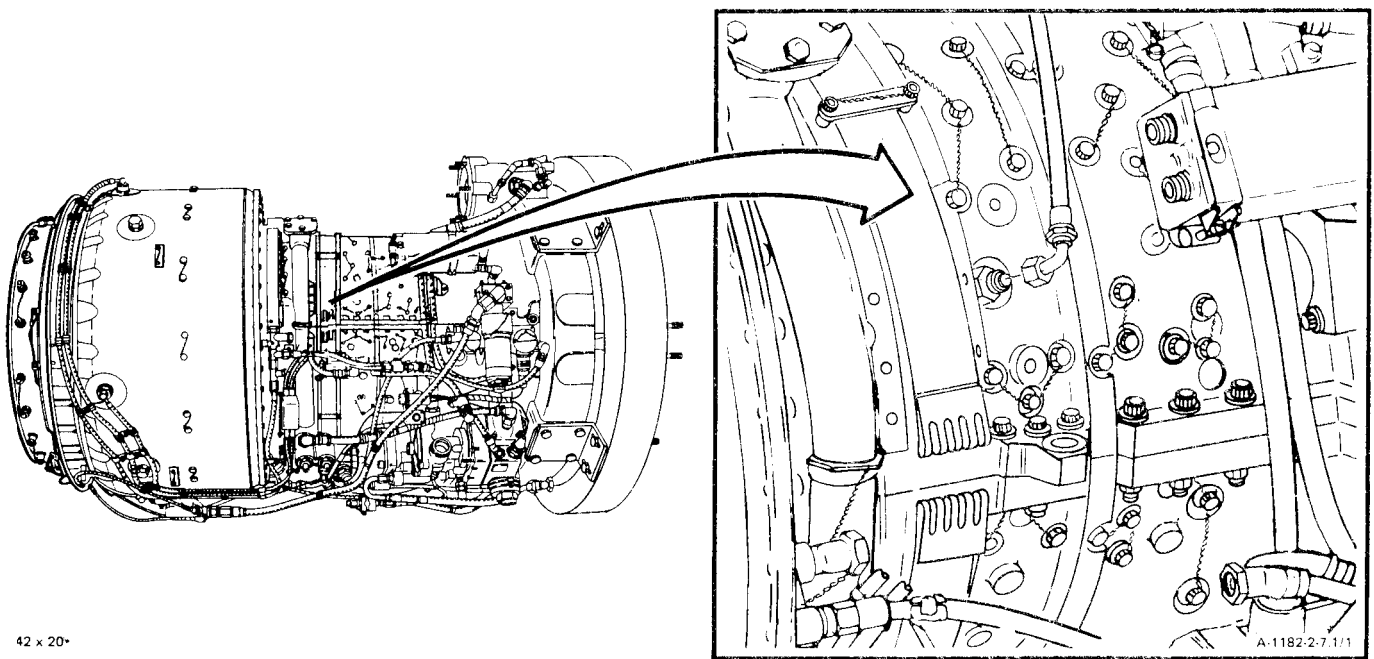

GO TO NEXT PAGE

2-7.1 INSTALL INTERSTAGE AIR-BLEED ACTUATOR WITH WATER WASH KIT
 P/N 2-200-071-54 INSTALLED) (Continued)

2-7.1

1. Install interstage air-bleed actuator (1) over ends of bleed band (2) and on compressor housing (3).

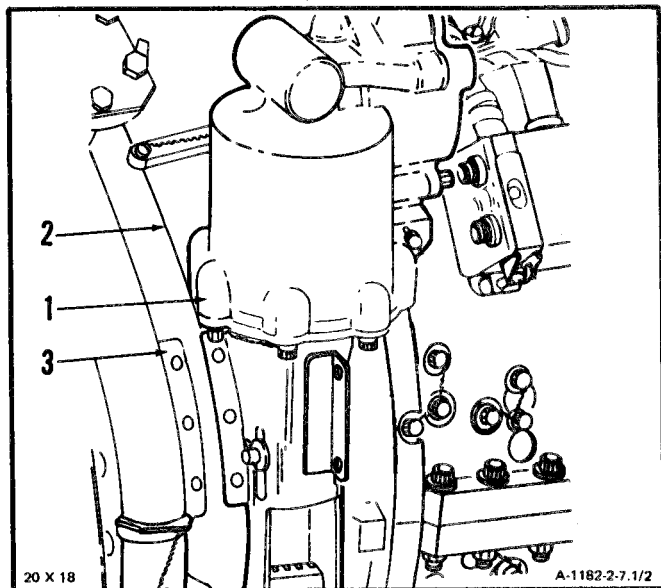

2. Position bleed band (2) and interlock bleed band upper and (4) with tangs on piston assembly (5).

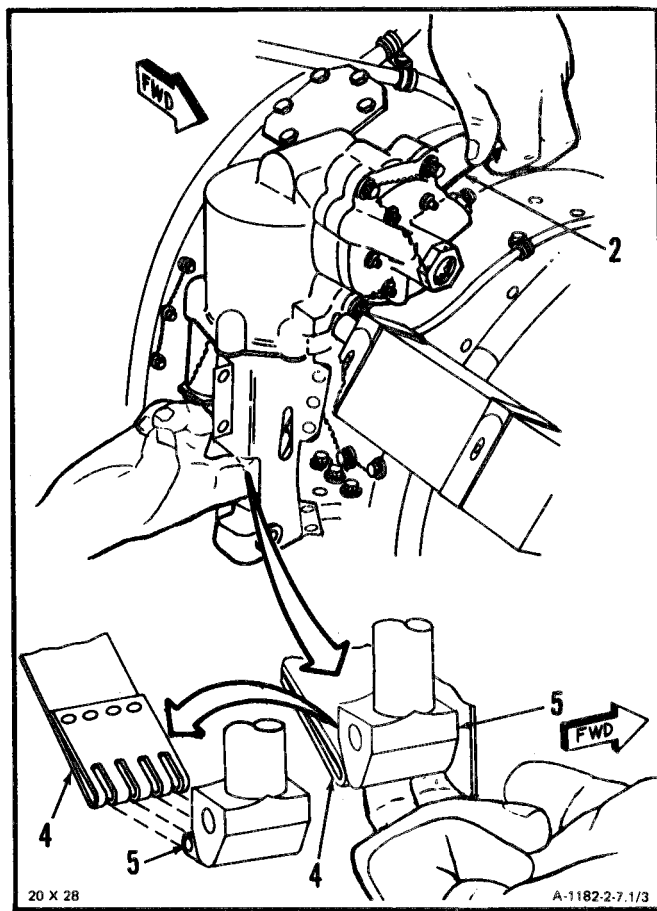

GO TO NEXT PAGE

2-7.1 INSTALL INTERSTAGE AIR-BLEED ACTUATOR (WITH WATER WASH KIT P/N 2-200-071-54 INSTALLED) (Continued)

2-7.1

3. Hold interlocked parts together and position them so bleed band upper end (4) is seen through slot (6). Install pin (7).

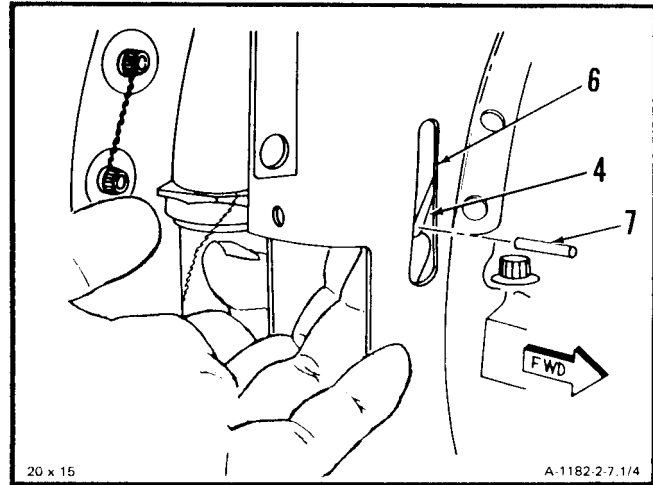

4. Interlock bleed band lower end (8) and tangs of yoke (9). Hold interlocked parts together and position them out of bracket (10). Install pin (11).

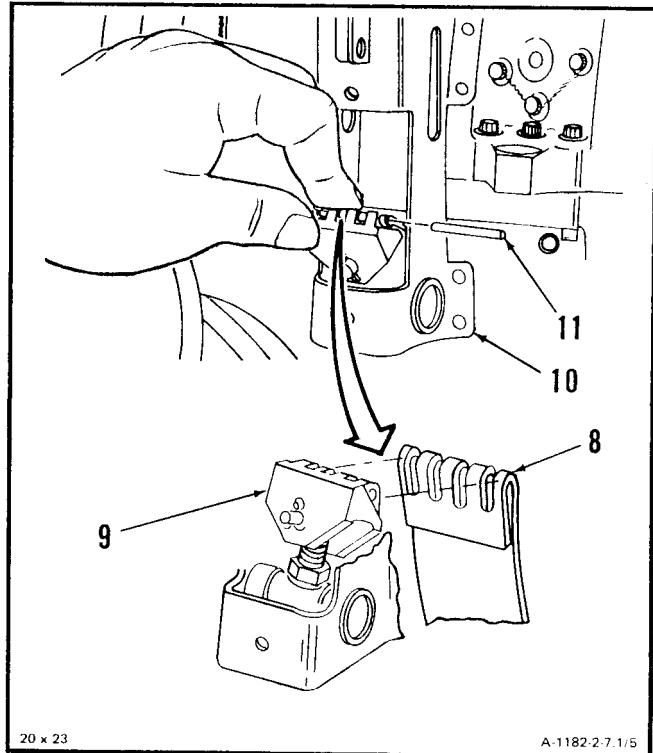

GO TO NEXT PAGE

2-7.1 INSTALL INTERSTAGE AIR-BLEED ACTUATOR (WITH WATER WASH KIT PIN 2-200-071-54 INSTALLED) (Continued)

2-7.1

5. Position piston assembly (5) so hole (12) can be seen through slot (6). Install pin (13), washer (14), and cotter pin (15).

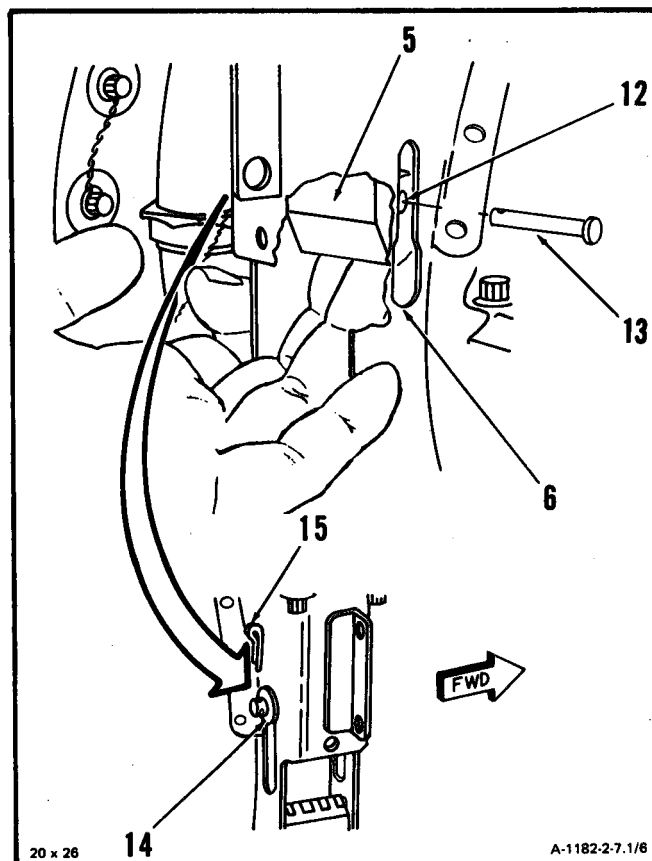

6. Install on compressor housing. Secure with two bolts (16) and eight bolts (17). Torque two top bolts (16) to ten inch-pounds. Torque remaining eight bolts (17) in pairs 180 degrees apart in rotation to 20 inch-pounds initial torque. Retorque same eight bolts (17) in same sequence to 35 to 40 inch-pounds. LockWire ten bolts (16 and 17). Use lockwire (E29).

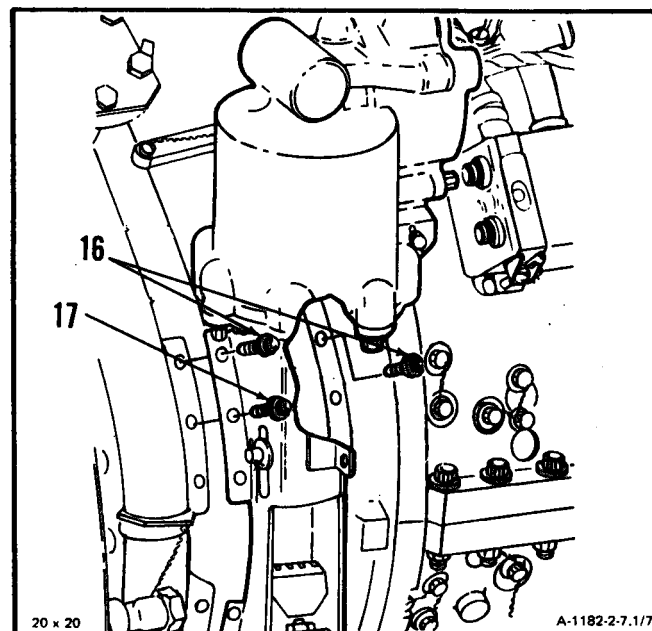

GO TO NEXT PAGE

2-7.1 INSTALL INTERSTAGE AIR-BLEED ACTUATOR (WITH WATER WASH KIT P/N 2-200-071-54 INSTALLED) (Continued)

2-7.1

7. Connect tube assembly(18) to union (19).

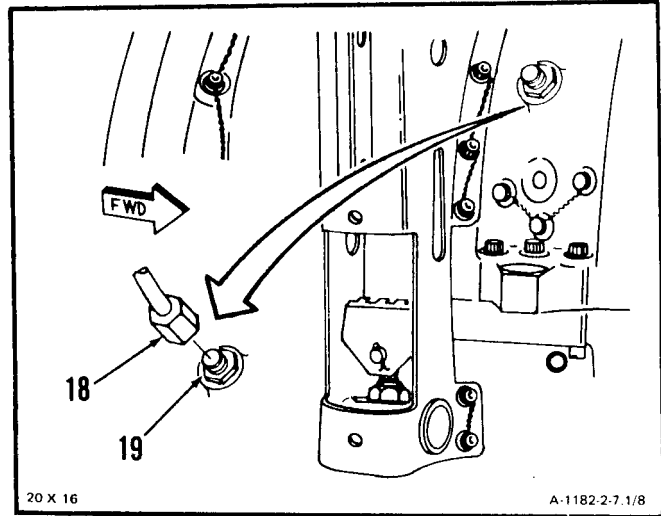

8. Install tee (20) on reducer (21).
9. Install nut (22) on tee (23). Install packing (24) on tee (23). Position nut to make sure packing is in groove between two sets of threads on tee.
10. Install tee (23) into air-bleed port (25).
11. Adjust interstate air-bleed actuator (Ref. Task 2-8, steps 6. thru 17.)

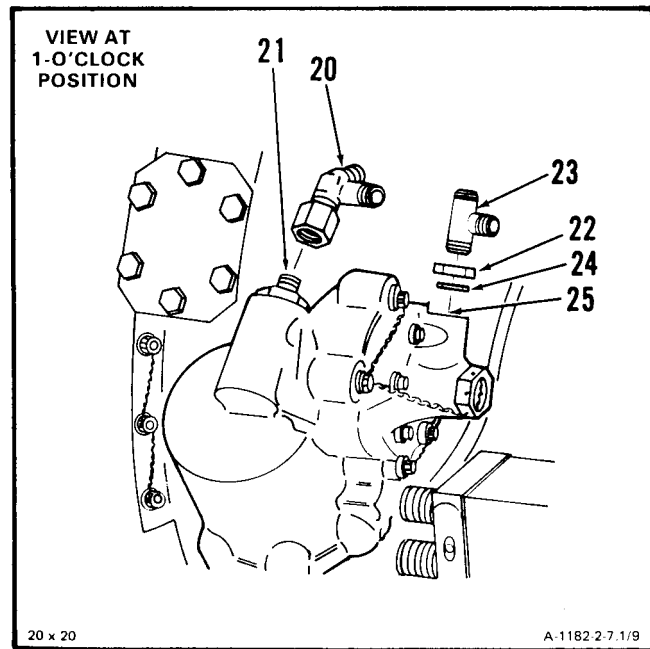

GO TO NEXT PAGE

2-7.1 INSTALL INTERSTAGE AIR-BLEED ACTUATOR (WATER WASH KIT
P/N 2-200-071-54 INSTALLED) (Continued)

2-7.1

12. Connect hose assembly (26 and 27) to tee (20).
13. Connect hose assembly (28 and 29) tee (23).

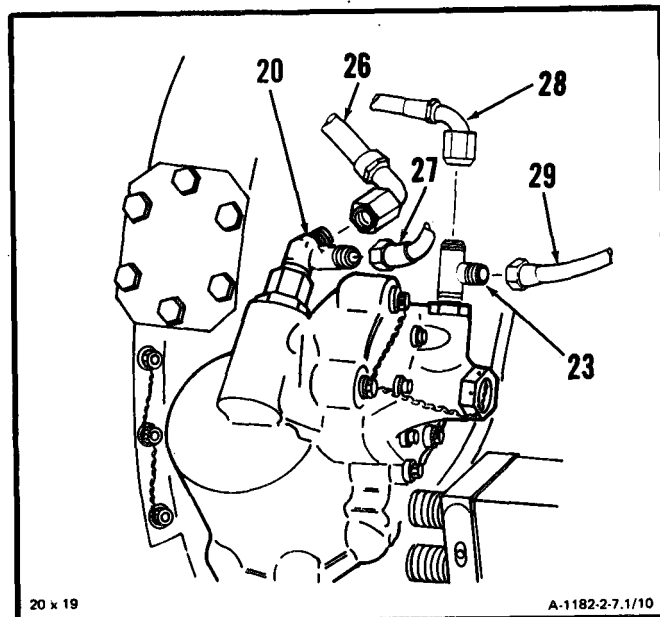

14. Connect two coil and cable assembly leads (30) to igniton exciter output receptacles (31). Lockwire leads. Use lockwire (E29).
15. Install screw (32) and nut (33).

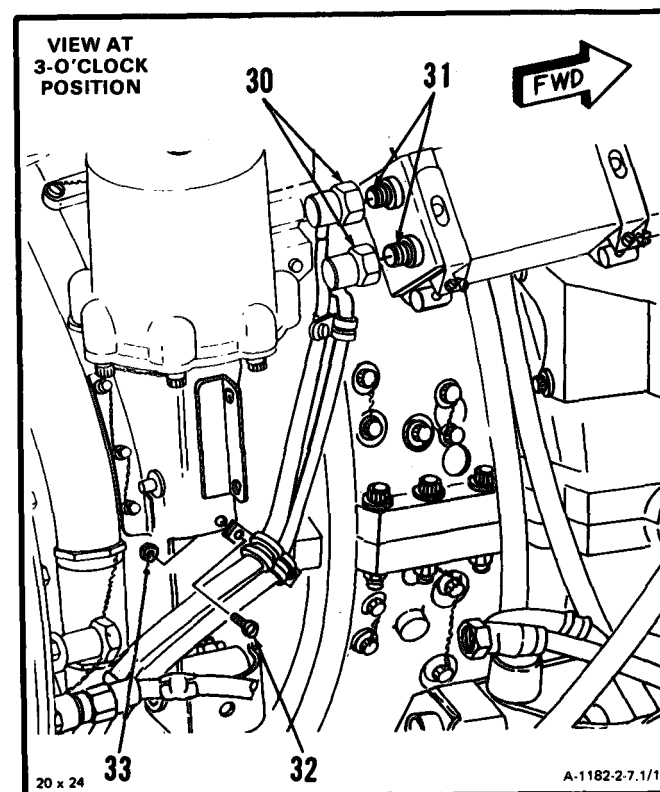

INSPECT

GO TO NEXT PAGE

2-7.1 INSTALL INTERSTAGE AIR-BLEED ACTUATOR (WITH WATER WASH KIT 2-7.1
P/N 2-200-071-54 INSTALLED) (Continued)

FOLLOW-ON MAINTENANCE:

Install Oil Cooler Assembly (Task 8-11).

Perform Bleed Band Closure Check (Task 1-107).

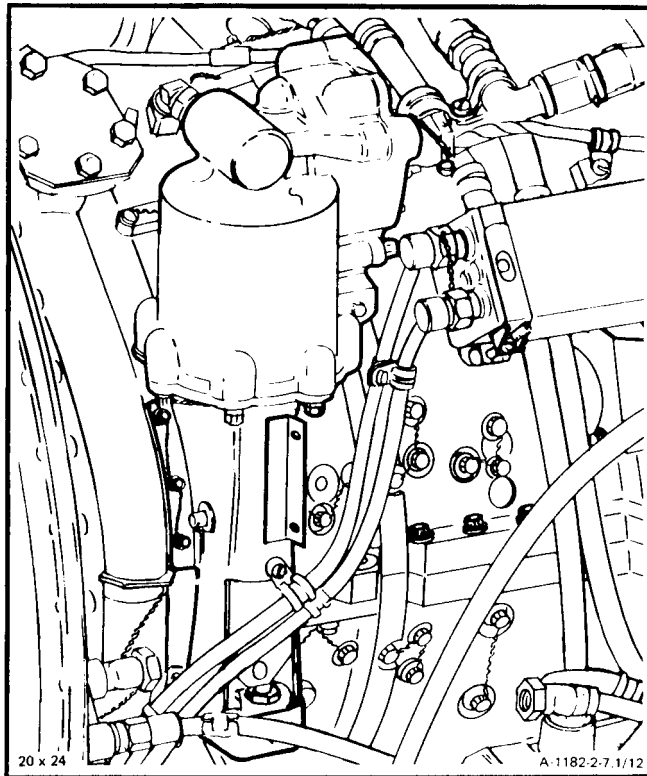

END OF TASK

2-28.6 Change 5

2-8 ADJUST INTERSTAGE AIR-BLEED ACTUATOR (WITHOUT WATER WASH KIT-8 P/N 2-200-071-54 INSTALLED)

INITIAL SETUP

Applicable Configurations:
All

Tools:

- Powerplant Mechanic's Tool Kit,
NSN 5180-00-323-4944
- Technical Inspection Tool Kit,
NSN 5180-00-323-5114
- Compressed Air Source
- Torque Wrench, 30-150 Inch-Pounds

Materials:

- Carborundum Stone (E10)
- Crocus Cloth (E15)
- Dry Cleaning Solvent (E17)
- Gloves (E20)
- Lockwire (E29)
- Wiping Rag (E58)

Personnel Required:

- 68B10 Aircraft Powerplant Repairer
- 68B30 Aircraft Powerplant Inspector

References:

- Task 2-9
- Task 2-13

Equipment Condition:

- Oil Cooler Assembly Removed (Task 8-5)

General Safety Instructions:

WARNING

The ignition exciter stores very high and possibly fatal voltage. Use extreme care when working around ignition exciter. Serious injury could result if exciter is accidentally grounded. Do not probe inside of output receptacles **with fingers** or metal object. Discharge exciter only with insulated screwdriver. In case of shock or injury, get medical attention.

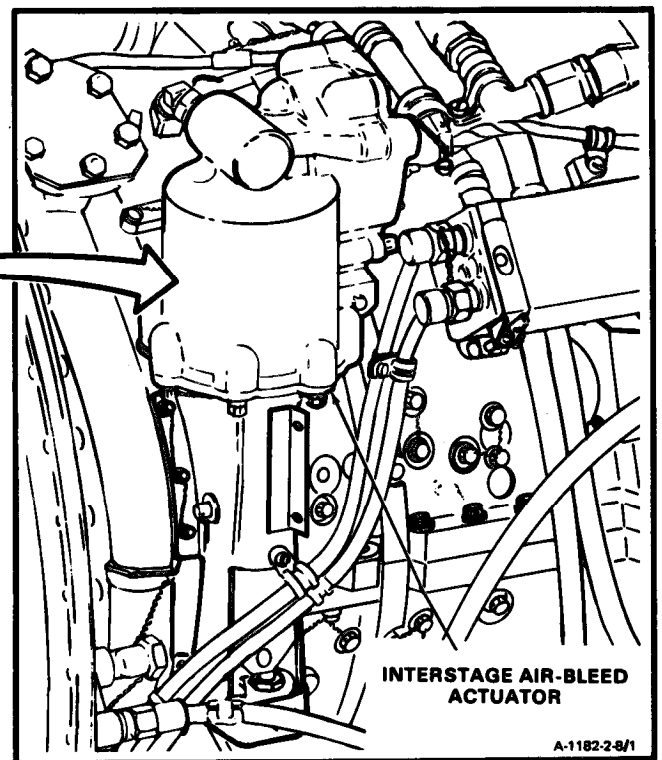
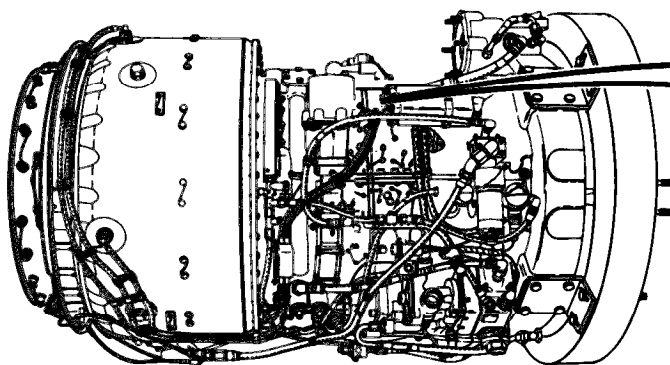

42 x 24

GO TO NEXT PAGE

2-8 ADJUST INTERSTAGE AIR-BLEED ACTUATOR (WITHOUT' WATER WASH KIT P/N 2-200-071-54 INSTALLED) (Continued)

2-8

NOTE

Adjustment of interstate air-bleed actuator can be done with oil cooler removed or installed. This task is shown with oil cooler removed. Procedure is the same.

When discharging ignition exciter, remove one lead at a time and discharge receptacle that lead was removed from. Failure to do so may result in serious shock when you are removing second lead. In case of serious shock, get medical attention.

1. Remove nut (1) and screw (2).

NOTE

Steps 2. and 3. apply to both output receptacles.

2. Remove lockwire and disconnect coil and cable assembly lead (3).

3. **Discharge ignition exciter (4)** by placing tip of insulated screwdriver (5) against pin (6) and edge (7) of receptacle (8).

4. Place leads (3) to one side.

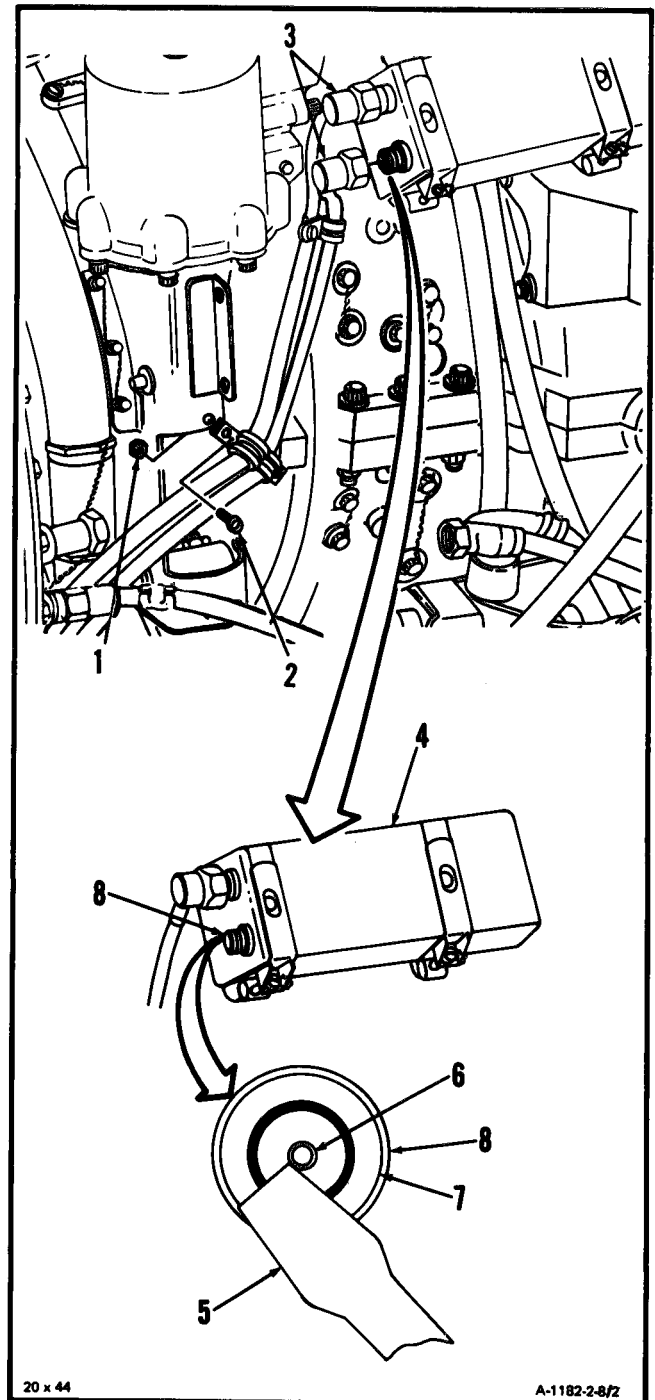

20 x 44

A-1182-2-8/2

GO TO NEXT PAGE

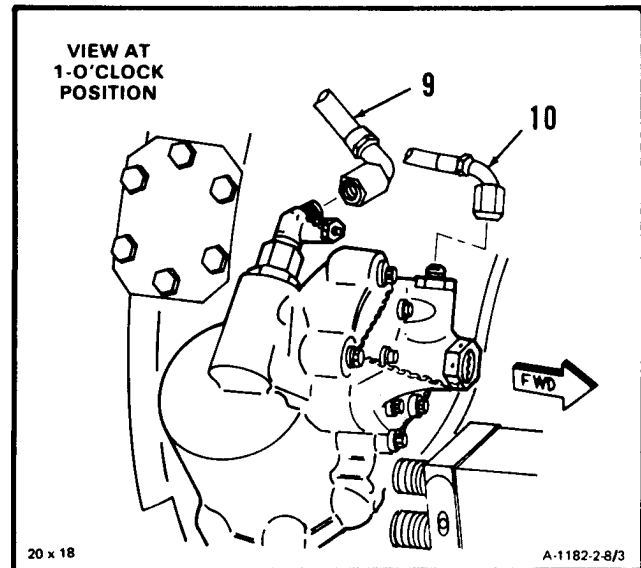
5. Disconnect hose assemblies (9 and 10).

Remove lockwire and **loosen upper nut (11)**
and lower nut (12) to allow full travel of actua-
tor piston (13).

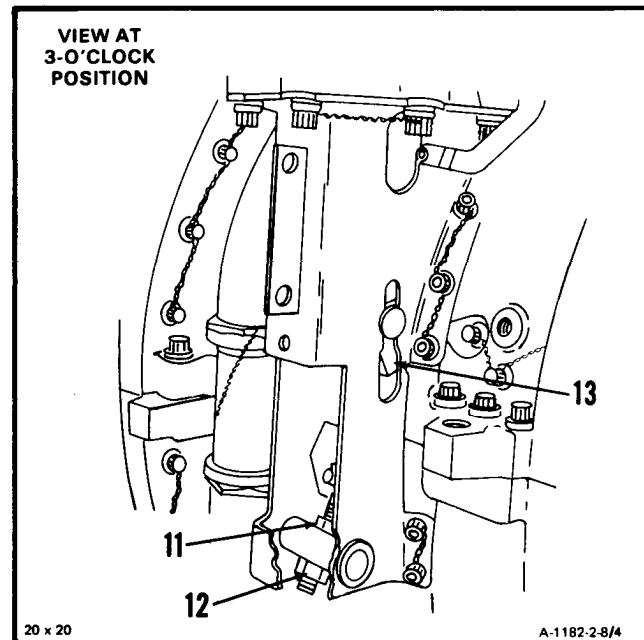
**NOTE**

Before adjusting actuator, area under bleed band
should be checked for foreign objects.

GO TO NEXT PAGE

2-8 ADJUST INTERSTAGE AIR-BLEED ACTUATOR (WITHOUT WATER WASH KIT P/N 2-200-071-54 INSTALLED) (Continued)

2-8

7. Connect air pressure hose from air compressor to tee (14). Apply 60 psig. air pressure.

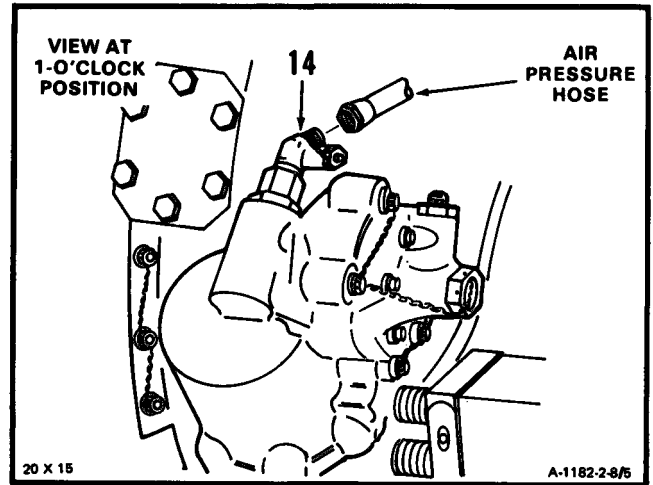

- 7.1 Visually check that there is no piston (13) movement in the open position.

8. Activate piston (13) to closed position by placing finger over union (15).

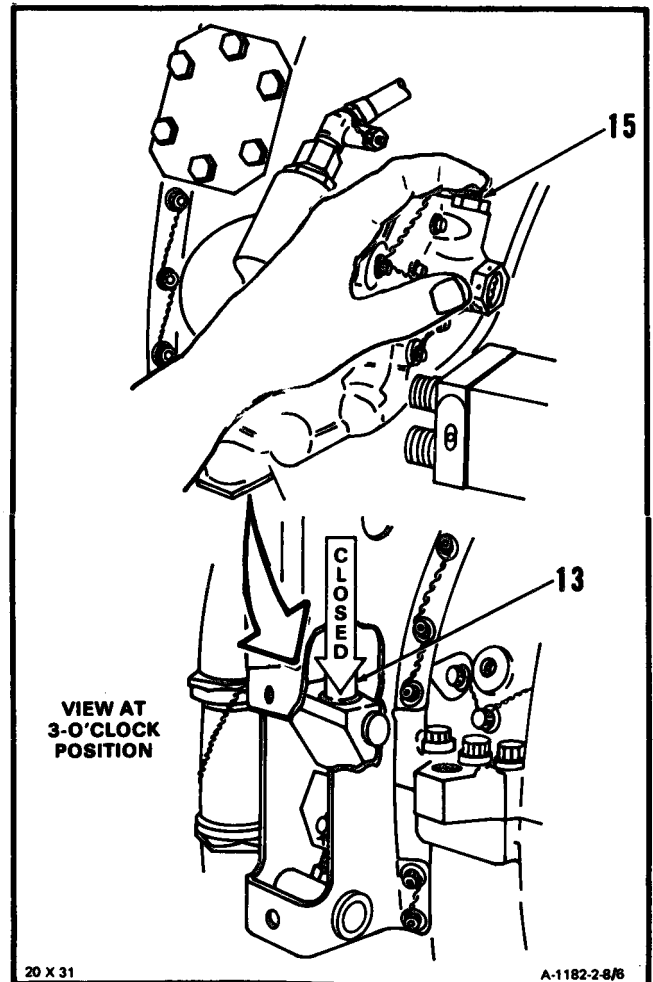

GO TO NEXT PAGE

2-8 ADJUST INTERSTAGE AIR-BLEED ACTUATOR (WITHOUT WATER WASH KIT
P/N 2-200-071-54 INSTALLED) (Continued)

2-8

9. Adjust nuts (11 and 12) until clearance between shaft of pin (16) and bottom of slot (17) is 1/8 to 3/16-inch.
10. Allow piston (13) to return to open position by removing finger from union.

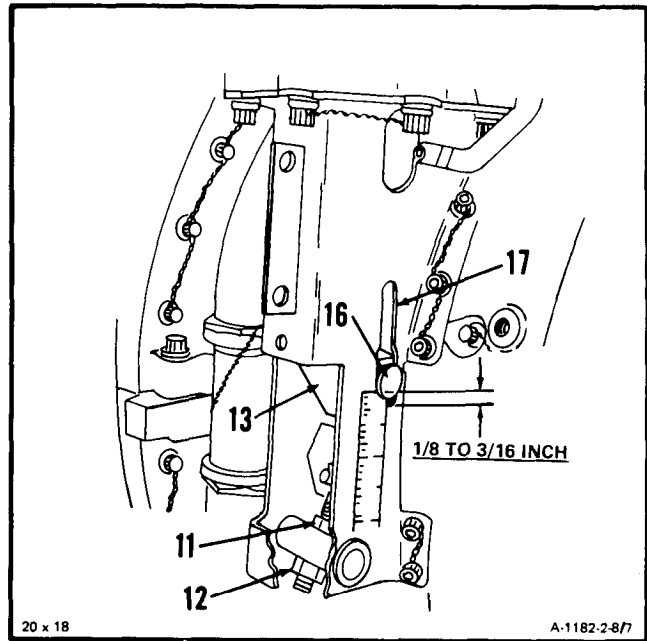

CAUTION

Do not allow yoke to twist when torquing nut. Twisting of yoke may cause binding and will not allow bleed band to close properly.

CAUTION

After torquing, two threads must remain showing below nut. Failure to comply may cause nut to break loose and prevent bleed band from closing. Replace bleed band if two threads do not show.

11. Position yoke (18) against compressor housing (19) and hold upper nut (11). Torque lower nut (12) to 145 pound-inch.

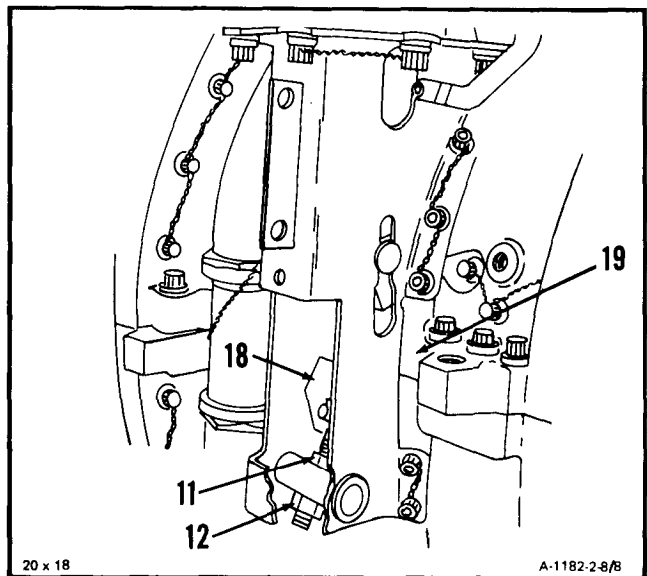

GO TO NEXT PAGE

2-8 ADJUST INTERSTAGE AIR-BLEED ACTUATOR (WITHOUT WATER WASH KIT P/N 2-200-071-54 INSTALLED) (Continued)

CAUTION

Make sure bleed band pins do not bind against actuator when piston moves to closed position. Binding will not allow bleed band to close properly.

12. Activate and release piston (13) several times. **Check that pins (20) are not binding.** If pins (20) are binding, reposition or replace pins (20).

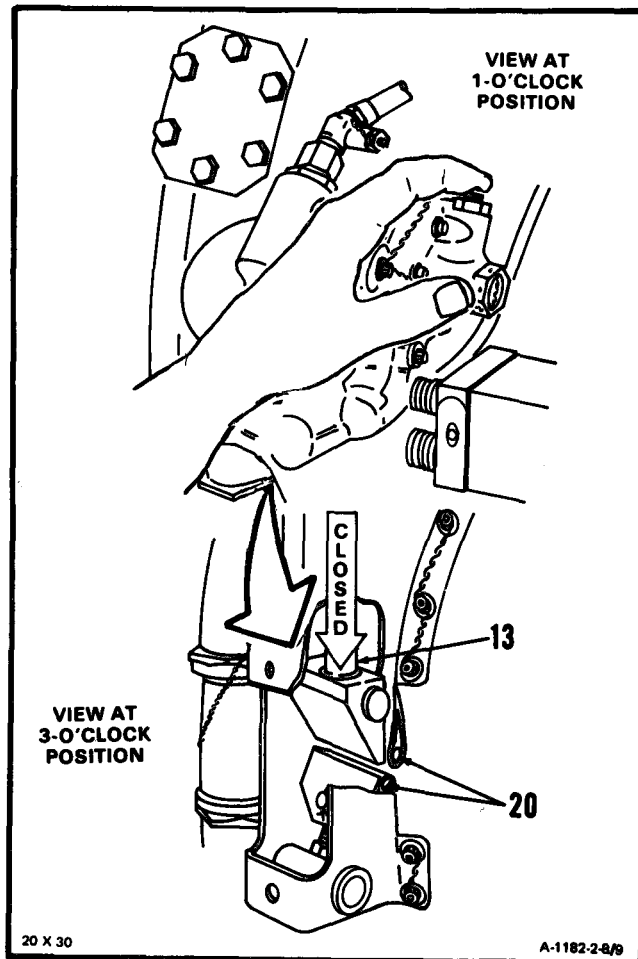

13. With piston (13) in closed position, **check clearance between shaft of pin (16) and bottom of slot (17).** Clearance shall be 1/8 to 3/16-inch. Allow piston(13) to return to open position.

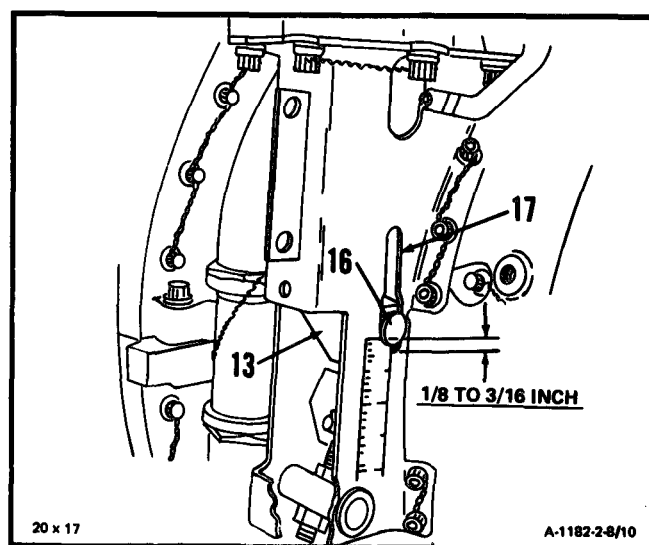

GO TO NEXT PAGE

14. Note location of pin (16). Activate piston (13) to closed position, and **measure distance pin (16) moves from open to closed**. Pin shall move at least 1.0 inch.

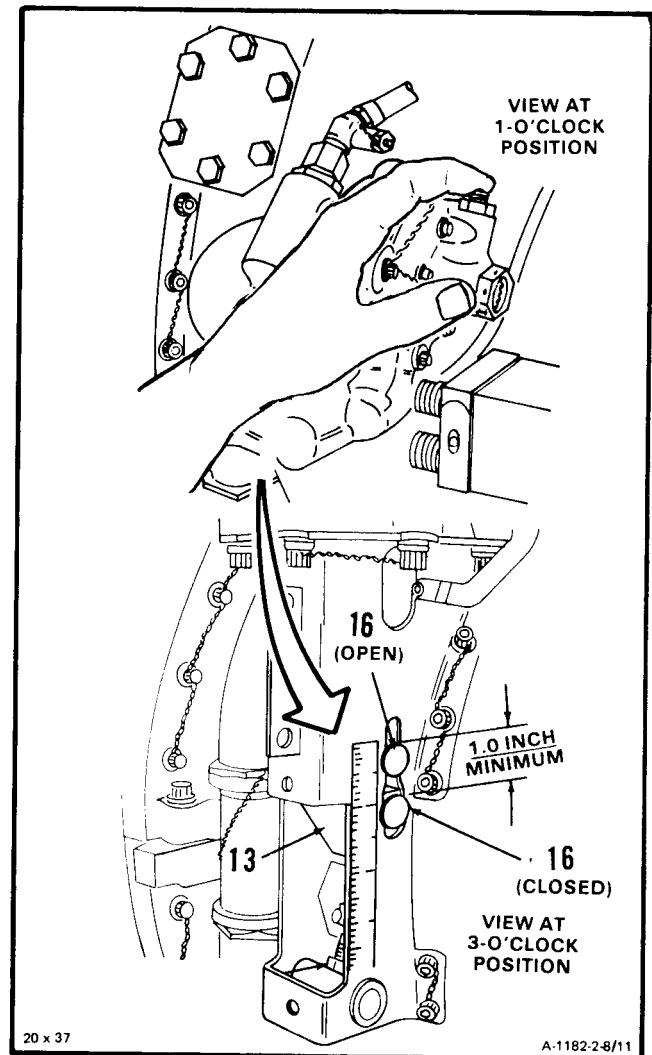

15. If you can not obtain clearance and minimum pin movement, proceed as follows until requirements are met:
- Readjust interstage air-bleed actuator** (steps 8. thru 13.).
 - If clearance and minimum pin movement cannot be obtained after readjustment replace compressor bleed band** (Ref. Tasks 2-9 and 2-13).

GO TO NEXT PAGE

**2-8 ADJUST INTERSTAGE AIR-BLEED ACTUATOR (WITHOUT WATER WASH KIT
P/N 2-200-071-54 INSTALLED) (Continued)**

2-8

16. Place finger over union (15). **Check clearance between bleed band (21) and compressor housing (19) at 12-, 5-, and 8-o'clock positions.** Use thickness gage. Clearance shall not be more than 0.002-inch drag fit. If fit is too loose, proceed as follows:
- Check bleed band (21)** for twists, kinks, and dirt or other deposits on side that goes against compressor housing (19). **Replace bleed band (21) if twisted or kinked** (Ref. Task 2-9 and 2-13).

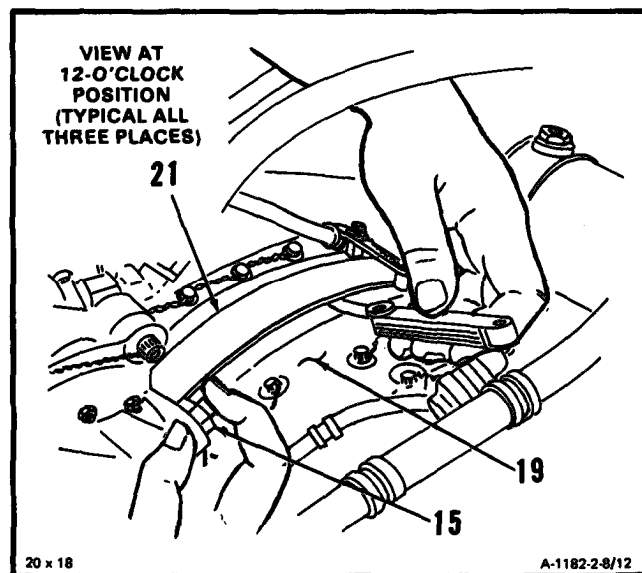
**GO TO NEXT PAGE**

- b. **Check compressor housing (19)** for nicks, chafing, and dirt or other deposits in bleed band area. If nicks, chafing, dirt or other deposits are found, proceed as follows:

- (1) **Remove compressor bleed band** (Ref. Task 2-9).

WARNING

Dry cleaning solvent (E17) is flammable and toxic. It can irritate skin and cause burns. Use only in well-ventilated area, away from heat and open flame. In case of contact immediately flush skin or eyes with water for at least **15 minutes**. Get medical attention for eyes.

- (2) **Clean compressor housing** as follows:

- (a) Wear gloves (E20), and clean compressor housing (19). Use brush and wiping rag (E58) dampened in dry cleaning solvent (E17).

WARNING

When using compressed air for cleaning, use approved protective equipment for eyes and face. Do not use more than **30 psig** air pressure. Do not direct air toward yourself or another person. Failure to comply could result in injury to eyes or skin. In case of injury, get medical attention.

- (b) Wear goggles. Blow dry compressor housing (19) using clean, dry compressed air.

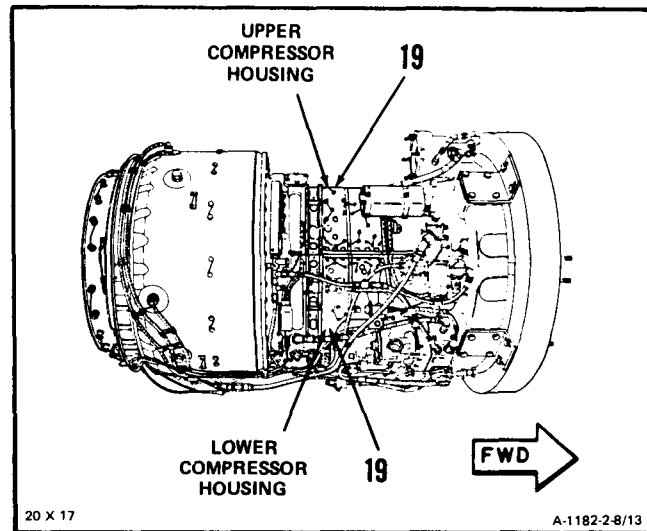

GO TO NEXT PAGE

(3) Inspect compressor housing (19) as follows:

- (a) There shall be no cracks.
- (b) There shall be no nicks, dents or gouges greater than 0.500 inch length to 0.007 inch depth.
- (c) There shall be no corrosion or paint

(4) Repair compressor housing as follows:

Repair of nicks, dents and gouges on outside diameter of compressor housing (19), is acceptable after blend-repair as follows:

- 1 Defects shall not project into mating surfaces.
- 2 **Repair gouges** up to 0.500 inch length to 0.070 inch depth.
 - a Blend all sharp edges using Carborundum stone (E10).
 - b Polish to smooth finish using crocus cloth (E15).
- 3 **Repair dents** up to 0.500 inch length to 0.070 inch depth.
 - a Blend all sharp edges using Carborundum stone (E10).
 - b Polish to smooth finish using crocus cloth (E15).
- 4 **Repair nicks** up to 0.500 inch length to 0.070 inch depth.
 - a Blend all sharp edges using Carborundum stone (E10).
 - b Polish to smooth finish using crocus cloth (E15).

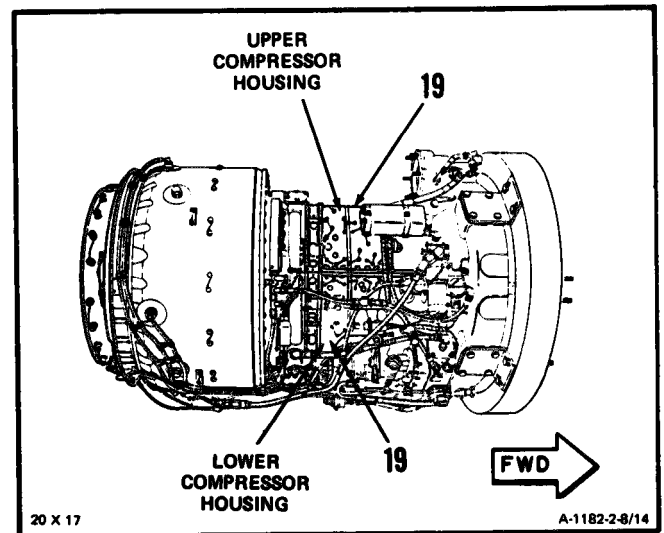

GO TO NEXT PAGE

2-8 ADJUST INTERSTAGE AIR-BLEED ACTUATOR (WITHOUT WATER WASH KIT
P/N 2-200-071-54 INSTALLED) (Continued)

(b) **Repair corrosion damage** up to 0.070
inch depth.

1 Blend all sharp edges using
Carborundum stone (E10).

2 Polish to smooth finish using crocus
cloth (E15).

(5) **Install compressor bleed band** (Ref. Task
2-13)

17. **Lockwire nuts (11 and 12) together.** Use
lockwire (E29).

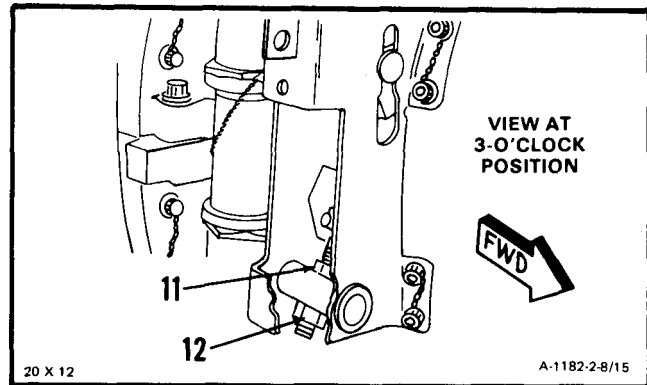

18. Disconnect air pressure hose from tee (14).

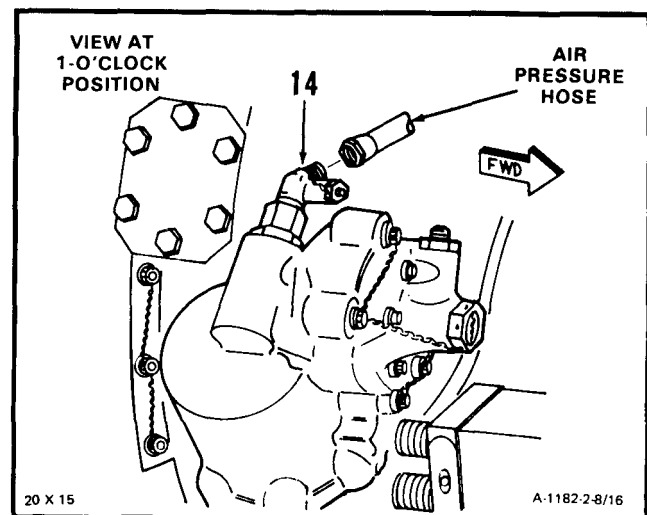

GO TO NEXT PAGE

2-8 ADJUST INTERSTAGE AIR-BLEED ACTUATOR (WITHOUT WATER WASH KIT P/N 2-200-071-54 INSTALLED) (Continued)

19. **Connect hose assembly (9) to tee (14).**

20. **Connect hose assembly (10) to union (15).**

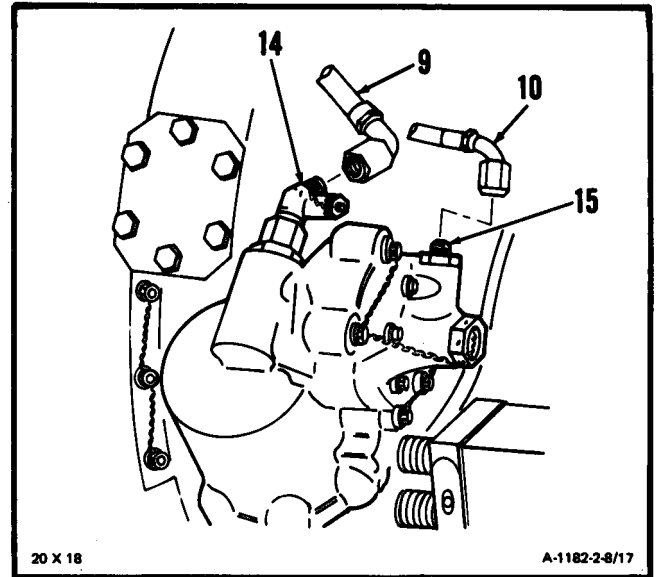

21. **Connect two coil and cable assembly leads (3) to ignition excitor output receptacles (8). Lockwire lead connectors. Use lockwire (E29).**

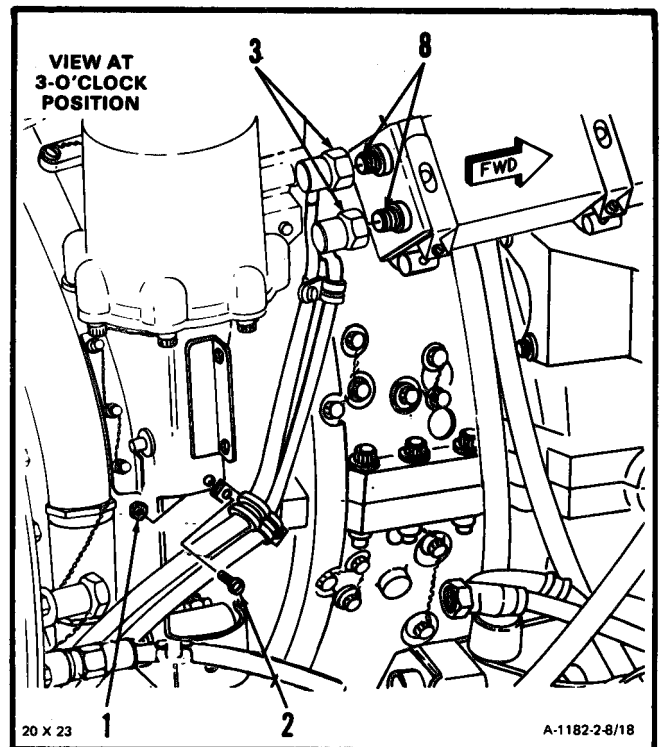

22. **Install screw (2) and nut(1).**

INSPECT

GO TO NEXT PAGE

FOLLOW-ON MAINTENANCE:

If Removed, Install Oil Cooler Assembly
(Task 8-11).

Perform Bleed Band Closure Check (Task 1-107).

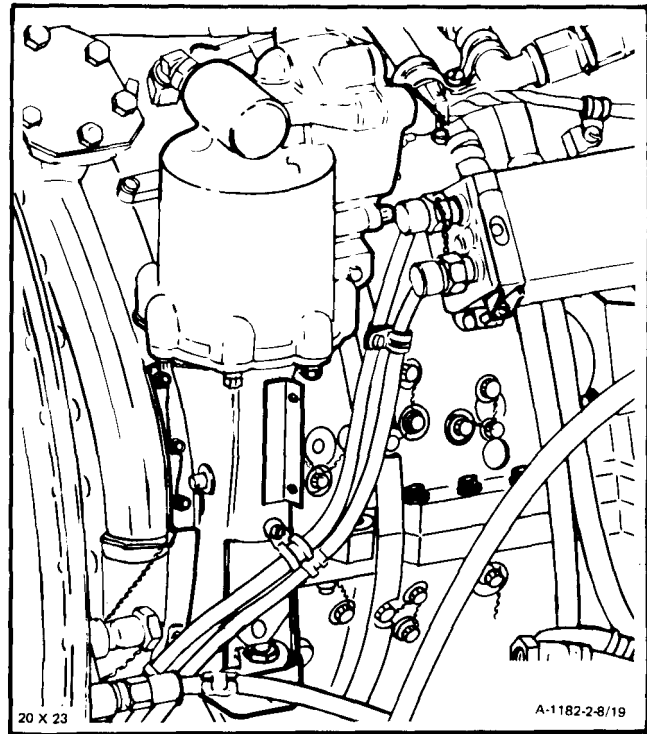

END OF TASK

2-8.1 ADJUST INTERSTAGE AIR-BLEED ACTUATOR (WITH WATER WASH KIT PIN 2-200-071-54 INSTALLED)

2-8.1

INITIAL SETUP

Applicable Configurations:

All

Tools:

Powerplant Mechanic's Tool Kit,
NSN 5180-00-323-4944
Technical Inspection Tool Kit,
NSN 5180-00-3235114
Compressed Air Source
Torque Wrench, 30-150 Inch-Pounds

Materials:

Carborundum Stone (E10)
Crocus cloth (E15)
Dry Cleaning Solvent (E17)
Gloves (E20)
Lockwire (E29)
Vviping Rag (E58)
Tube cap MS9314-03

Personnel Required:

68B100 Aircraft Powerplant Repairer
68B30 Aircraft Powerplant Inspector

References:

Task 2-9
Task 2-13

Equipment Condition:

Oil Cooler Assembly Removed (Task 8-5)

General Safety Instructions:

WARNING

The ignition exciter stores very high and possibly fatal voltage. Use extreme care when working around ignition exciter. Serious injury could result if exciter is accidentally grounded. Do not probe inside of output receptacles with fingers or metal object. Discharge exciter only with insulated screwdriver. In case of shock or injury, get medical attention.

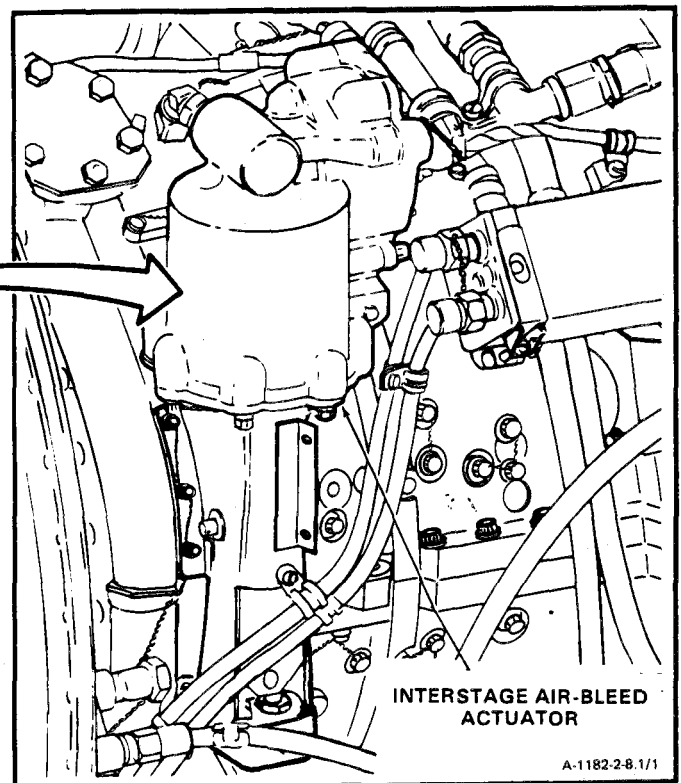
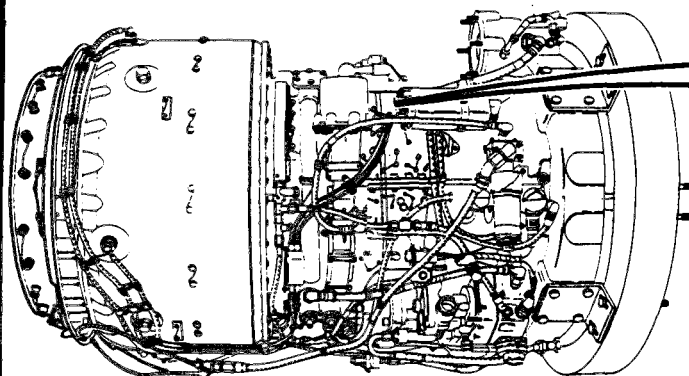

A-1182-2-8.1/1

42 x 24
GO TO NEXT PAGE

2-8.1 ADJUST INTERSTAGE AIR-BLEED ACTUATOR (WITH WATER WASH KIT
P/N 2-200-071-54 INSTALLED) (Continued)

2-8.1

NOTE

Adjustment of interstage air-bleed actuator can be done with oil cooler removed or installed. This task is shown with oil cooler removed. Procedure is the same.

WARNING

When discharging ignition exciter, remove one lead at a time and discharge receptacle that lead was removed from. Failure to do so may result in serious shock when you are removing second lead. In case of serious shock, get medical attention.

1. Remove nut (1) and screw (2).

NOTE

Steps 2. and 3. apply to both output receptacles.

2. Remove lockwire and disconnect coil and cable assembly lead (3).

3. Discharge ignition exciter (4) by placing tip of insulated screwdriver (5) against pin (6) and edge (7) of receptacle (8).

4. Place leads (3) to one side.

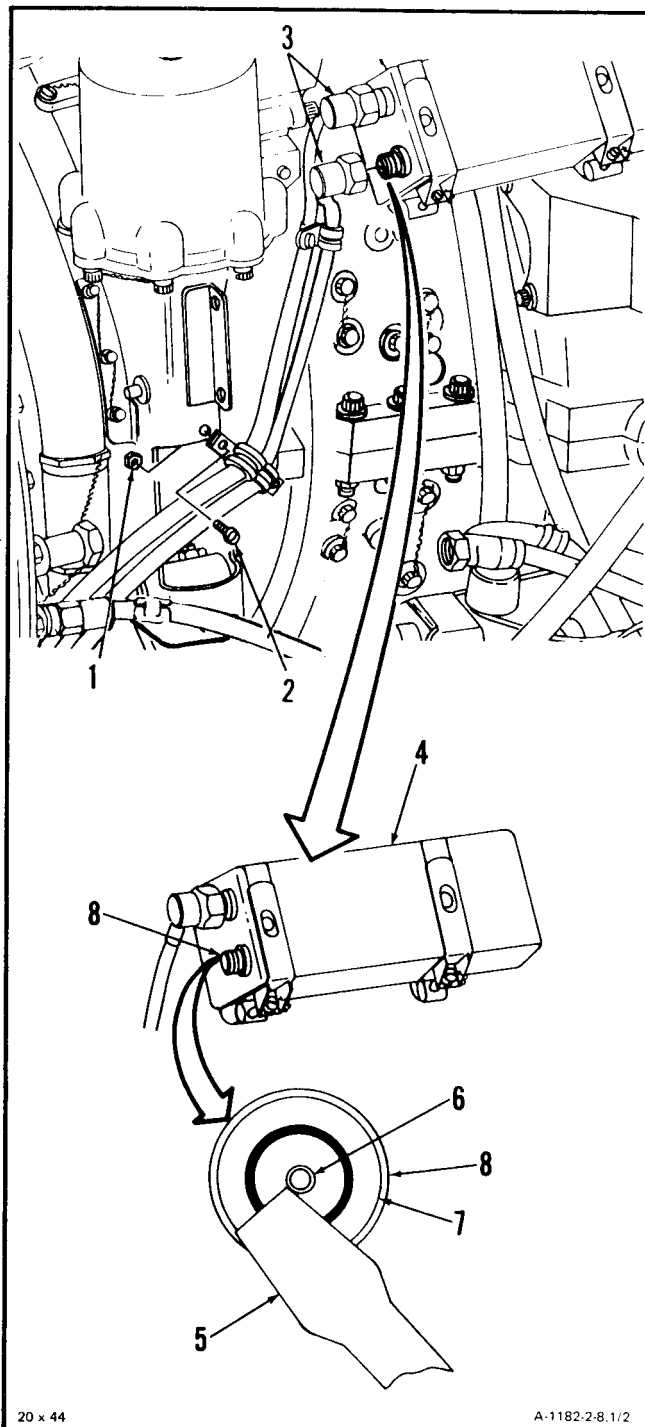

20 x 44

A-1182-2-8.1/2

GO TO NEXT PAGE

2-8.1 ADJUST INTERSTAGE AIR-BLEED ACTUATOR (WITH WATER WASH KIT P/N 2-200-071-54 INSTALLED) (Continued)

2-8.1

5. Disconnect hose assemblies (9, 10, 11 and 12).

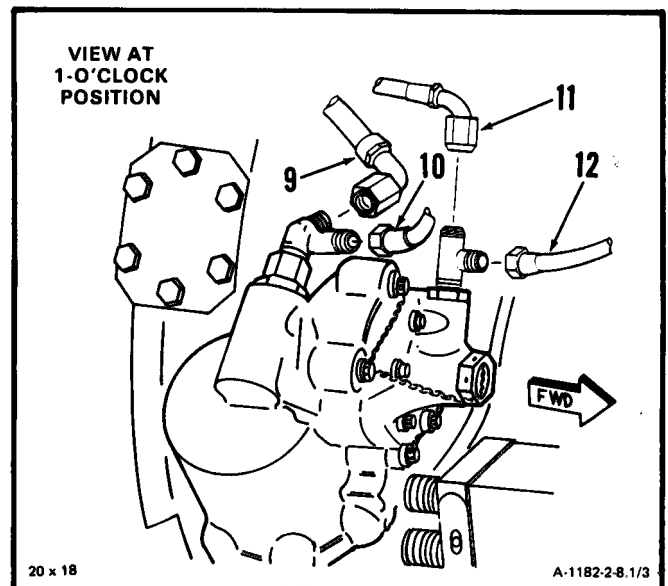

6. Remove lockwire and loosen **upper nut (13)** and **lower nut (14)** to allow full travel of actuator piston (15).

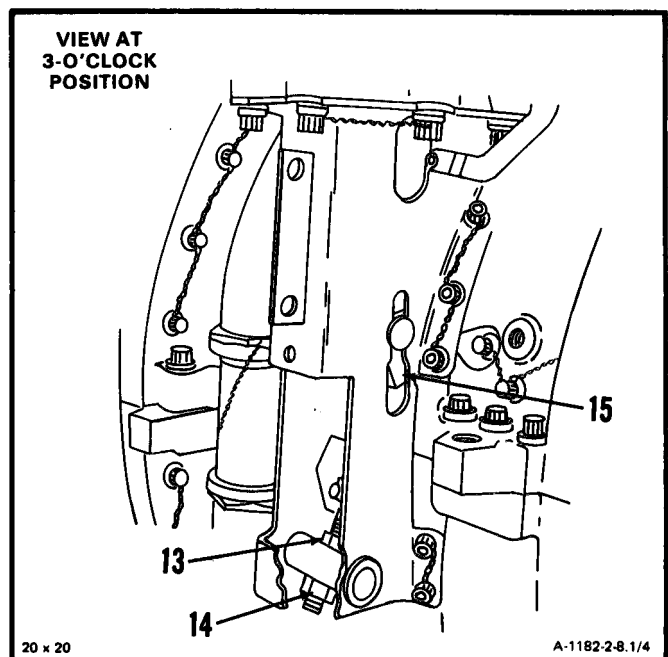

NOTE

Before adjusting actuator, area under bleed band should be checked for foreign objects.

GO TO NEXT PAGE

2-8.1 ADJUST INTERSTAGE AIR-BLEED ACTUATOR (WITH WATER WASH KIT P/N 2-200-071-54 INSTALLED) (Continued)

2-8.1

7. Install tube cap (16) to tee (17).
8. Connect air pressure hose from air compressor to tee (17). Apply 60 psig air pressure.

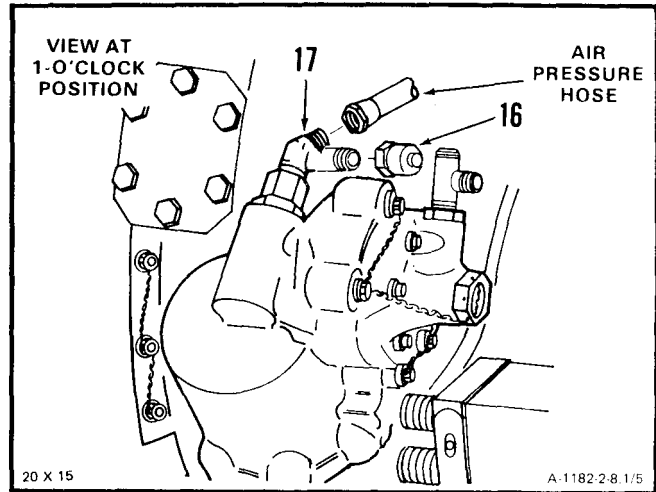

- 8.1. Visually check that there is no piston (5) movement in the open position.
9. **Activate piston (15) to closed position** by placing fingers over two opening of tee (18).

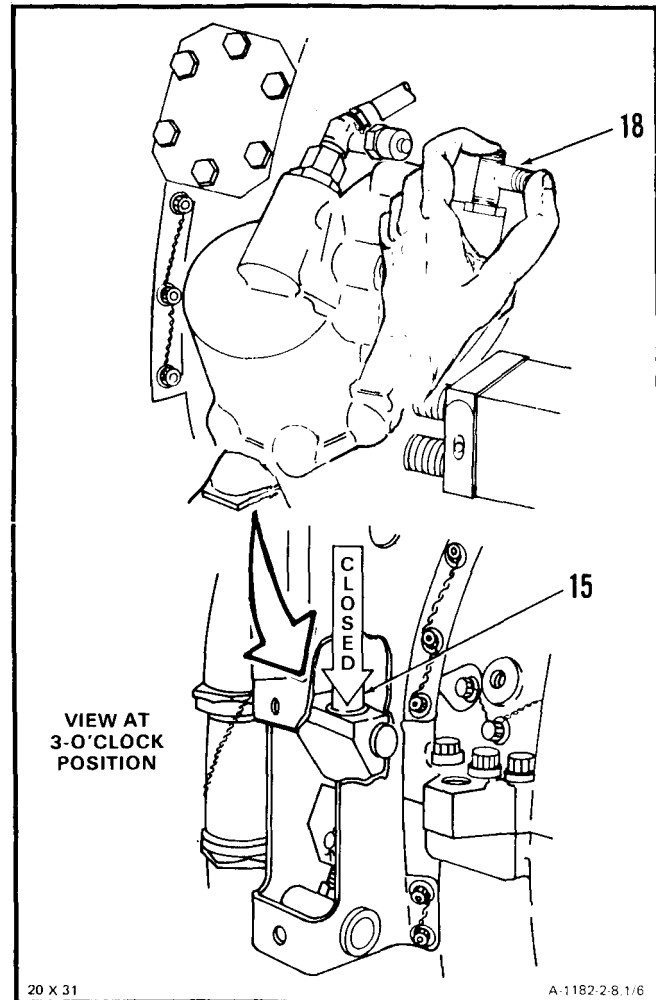

GO TO NEXT PAGE

2-8.1 ADJUST INTERSTAGE AIR-BLEED ACTUATOR (WITH WATER WASH KIT P/N 2-200-071-54 INSTALLED) (Continued)

2-81

10. Adjust nuts (13 and 14) until clearance between shaft of pin (19) and bottom of slot (20) is 1/8 to 3/16-inch.
11. **Allow piston (15) to return to open position** by removing fingers from tee.

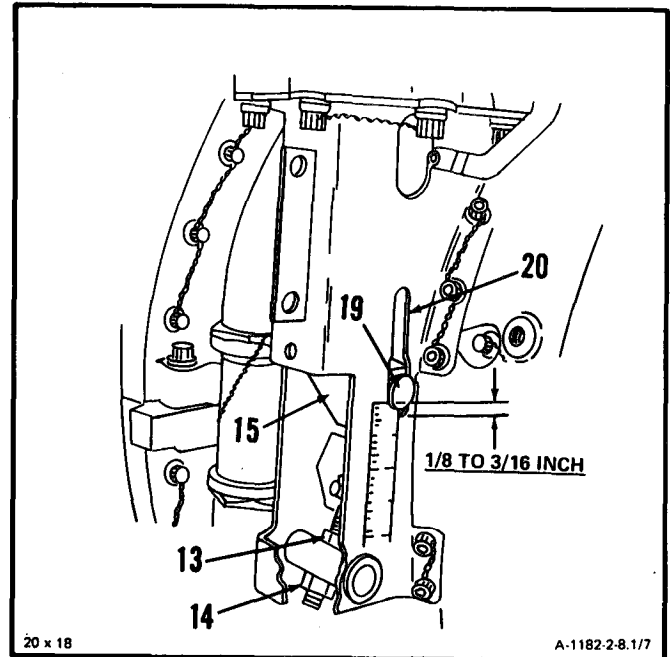

CAUTION

Do not allow yoke to twist when torquing nut. Twisting of yoke may cause binding and will not allow bleed band to close properly.

CAUTION

After torquing, two threads must remain showing below nut. Failure to comply may cause nut to break **hose** and prevent bleed band from closing. Replace bleed band if two threads do not show.

112. **Position yoke (21) against compressor housing (22) and hold upper nut (13).** Torque lower nut (14) 145 inch-pounds.

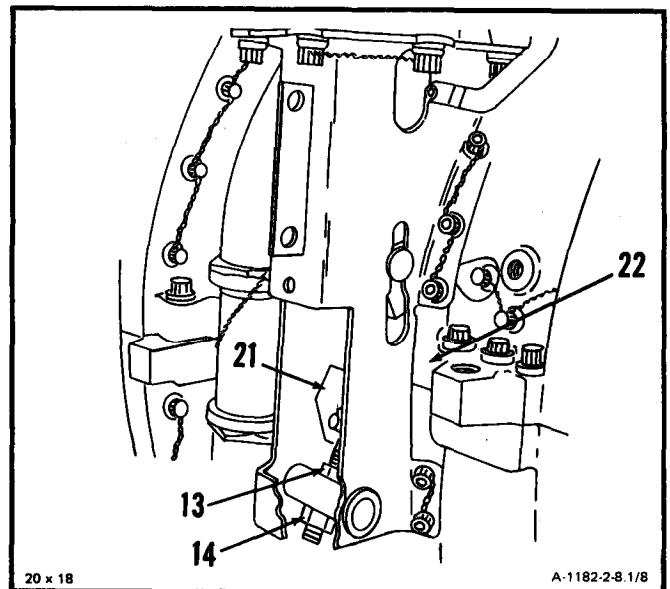

GO TO NEXT PAGE

2-8.1 ADJUST INTERSTAGE AIR-BLEED ACTUATOR (WITH WATER WASH KIT P/N 2-200-071-54 INSTALLED) (Continued)

2-8.1

CAUTION

Make sure bleed band pins do not bind against actuator when piston moves to closed position. Binding will not allow bleed band to close properly.

13. Activate and release piston (15) several times, **Check that pins (23) are not binding.** If pins (23) are binding, reposition or replace pins (23).

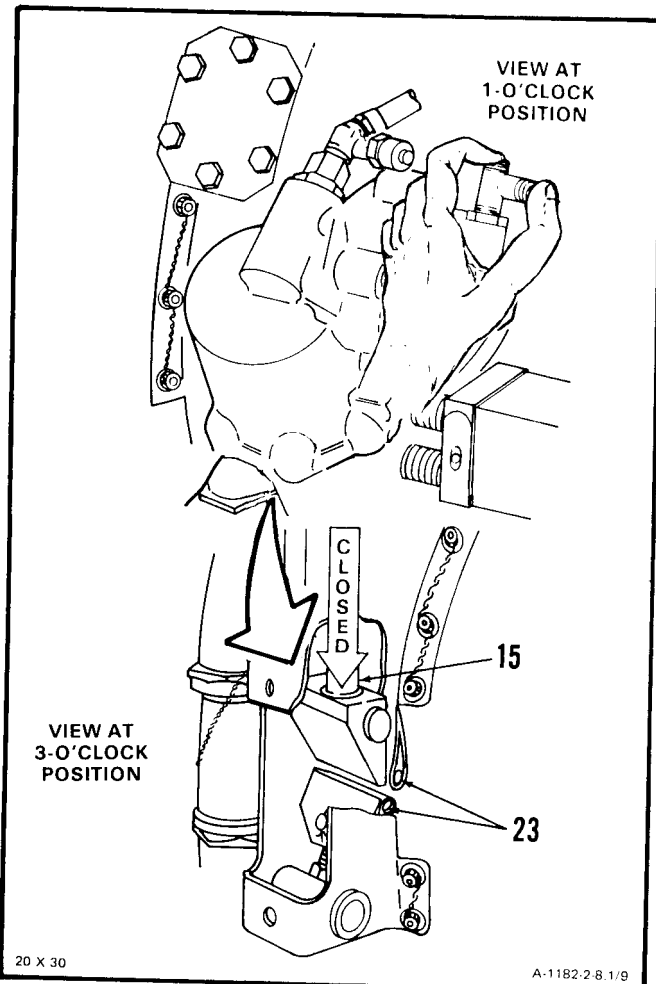

14. With piston (15) in closed position, **check clearance between shaft of pin (19) and bottom of slot (20).** Clearance shall be 1/8 to 3/16-inch. Allow piston (15) to return to open position.

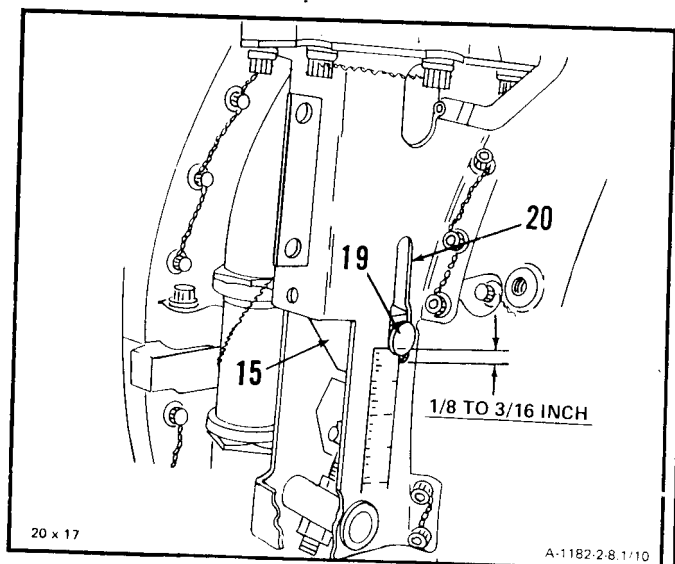
**GO TO NEXT PAGE**

2-8.1 ADJUST INTERSTAGE AIR-BLEED ACTUATOR (WITH WATER WASH KIT P/N 2-200-071-54 INSTALLED) (Continued)

2-8.1

15. Note location of pin (19). Activate piston (15) to closed position, and **measure distance pin (19) moves from open to closed**. Pin shall move at least 1.0 inch.

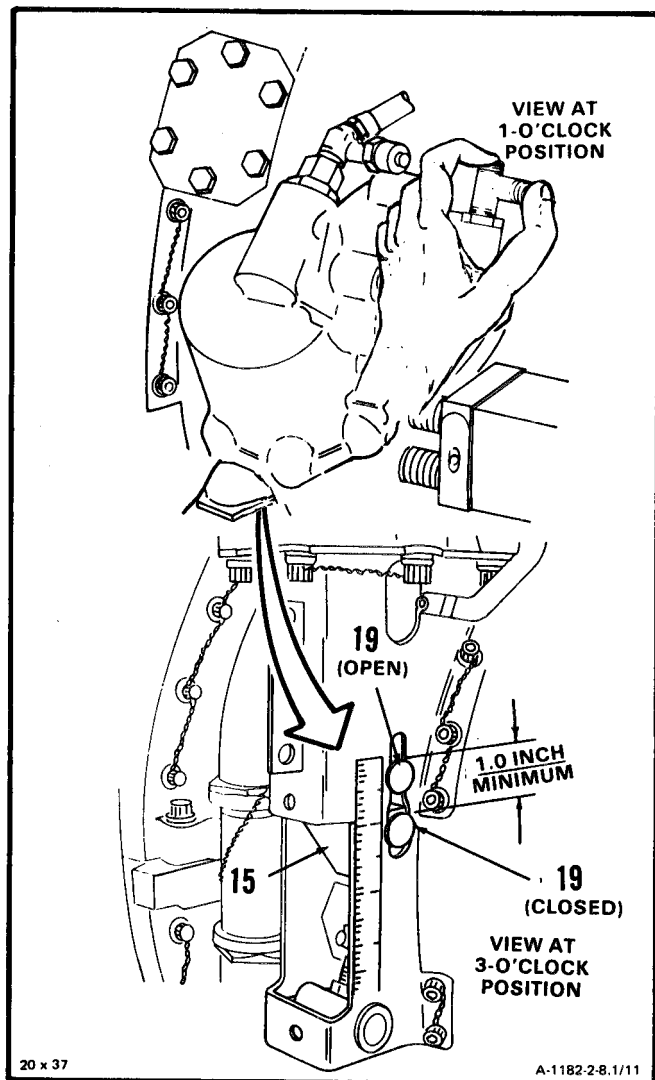

16. If you can not obtain clearance and minimum pin movement, proceed as follows until requirements are met

- a. **Readjust interstage air-bleed actuator** (steps 8. thru 13.).
- b. **If clearance and minimum pin movement cannot be obtained after readjustment replace compressor bleed band** (Ref. Tasks 2-9 and 2-13).

GO TO NEXT PAGE

2-8.1 ADJUST INTERSTAGE AIR-BLEED ACTUATOR (WITH WATER WASH KIT P/N 2-200-071-54 INSTALLED) (Continued)

2-8.1

17. Place fingers over two port openings on tee (18). **Check clearance between bleed band (24) and compressor housing (22) at 12-, 5-, and 8-o'clock positions.** Use thickness gage. Clearance shall not be more than 0.002-inch drag fit. **If fit is too loose**, proceed as follows:

- a. **Check bleed band (24)** for twists, kinks, and dirt or other deposits on side that goes against compressor housing (22). **Replace bleed band (24) if twisted or kinked** (Ref. Task 2-9 and 2-13).

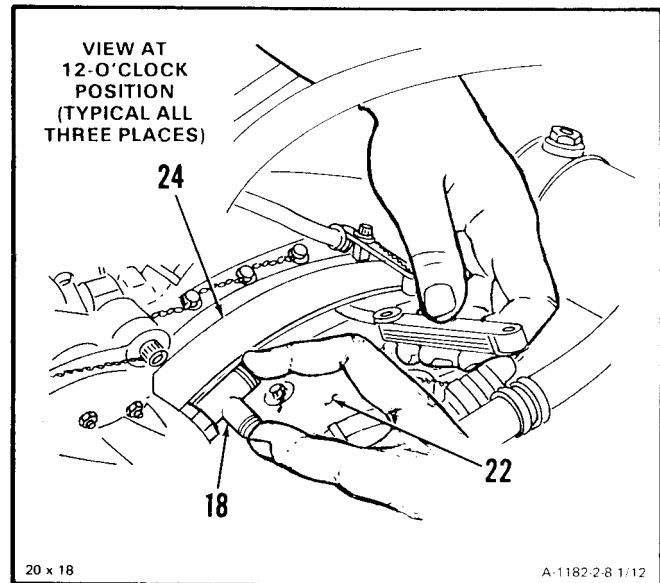

GO TO NEXT PAGE

2-8.1 ADJUST INTERSTAGE AIR-BLEED ACTUATOR (WITH WATER WASH KIT P/N 2-200-071-54 INSTALLED) (Continued)**2-8.1**

- b. Check compressor housing (22) for nicks, chafing, and dirt or other deposits in bleed band area. If nicks, chafing, dirt or other deposits are found, proceed as follows:

- (1) Remove compressor bleed band (Ref. Task 2-9).

WARNING

Dry cleaning solvent (E17) is flammable and toxic. It can irritate skin and cause burns. Use only in well-ventilated area, away from heat and open flame. In case of contact immediately flush skin or eyes with water for at least 15 minutes. Get medical attention for eyes.

- (2) Clean compressor housing as follows:

- (a) Wear gloves (E20), and clean compressor housing (22). Use brush and wiping rag (E58) dampened in dry cleaning solvent (E17).

WARNING

when using compressed air for cleaning, use approved protective equipment for eyes and face. Do not use more than 30 psig air pressure. Do not direct air toward yourself or another person. Failure to comply could result in injury to eyes or skin. In case of injury, get medical attention.

- (b) Wear goggles. Blow dry compressor housing (22) using clean, dry compressed air.

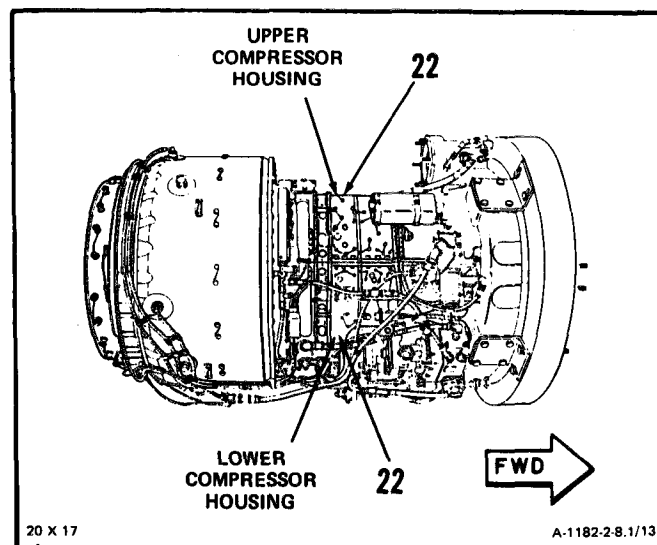
**GO TO NEXT PAGE**

**2-8.1 ADJUST INTERSTAGE AIR-BLEED ACTUATOR (WITH WATER WASH KIT
P/N 2-200-071-54 INSTALLED) (Continued)**

2-8.1

(3) **Inspect compressor housing (22)** as follows:

- (a) There shall be no cracks.
- (b) There shall be no nicks, dents or gouges greater than 0.500 inch length to 0.070 inch depth.
- (c) There shall be no corrosion or paint damage.

(4) **Repair compressor housing** as follows:

(a) Repair of nicks, dents and gouges on outside diameter of compressor housing (22), is acceptable after blend-repair as follows:

- 1 Defects shall not project into mating surfaces.
- 2 **Repair gouges** up to 0.500 inch length to 0.070 inch depth.
 - a Blend all sharp edges using Carborundum stone (E10).
 - b Polish to smooth finish using crocus cloth (E15).
- 3 **Repair dents** up to 0.500 inch length to 0.070 inch depth.
 - a Blend all sharp edges using Carborundum stone (E10).
 - b Polish to smooth finish using crocus cloth (E15).
- 4 **Repair nicks** up to 0.500 inch length to 0.070 inch depth.
 - a Blend all sharp edges using Carborundum stone (E10).
 - b Polish to smooth finish using crocus cloth (E15).

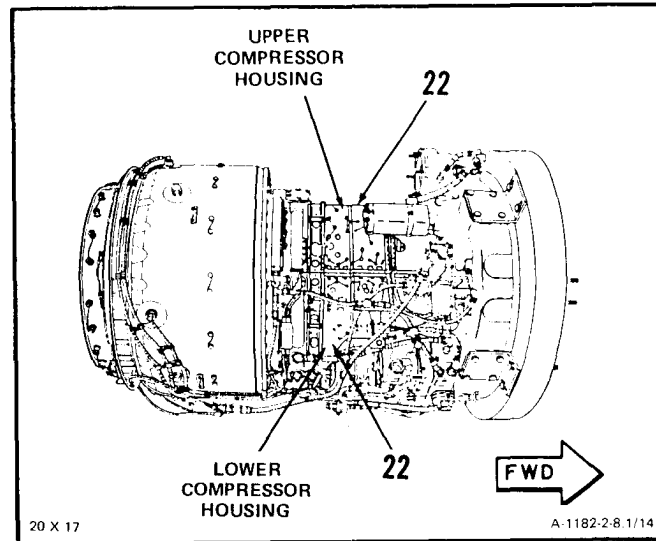

GO TO NEXT PAGE

2-8.1 ADJUST INTERSTAGE AIR-BLEED ACTUATOR (WITH WATER WASH KIT P/N 2-200071-54 INSTALLED) (Continued)

2-8.1

(b) **Repair corrosion damage** up to 0.070 inch dept

- 1 Blend all sharp edges using Carborundum stone (E10).
- 2 Polish to smooth finish using crocus cloth (E15).

(5) **Install compressor bleed band** (Ref. Task 2-13).

17. **Lockwire nuts (13 and 14) together.** Use

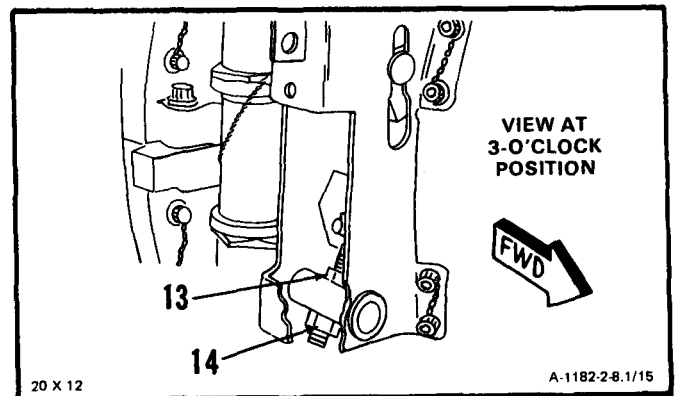

18. **Disconnect air pressure hose** from tee (17)

19. **Disconnect tube cap (16)** from tee (17).

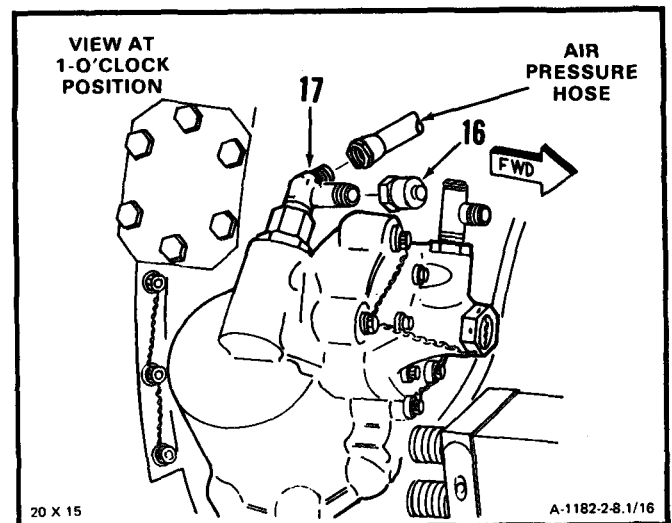

GO TO NEXT PAGE

2-8.1 ADJUST INTERSTAGE AIR-BLEED ACTUATOR (WITH WATER WASH KIT P/N 2-200-071-54 INSTALLED) (Continued)

2-8.1

20. Connect hose assembly (9 and 10) to tee (17).

21. Connect hose assembly (11 and 12) to tee (18).

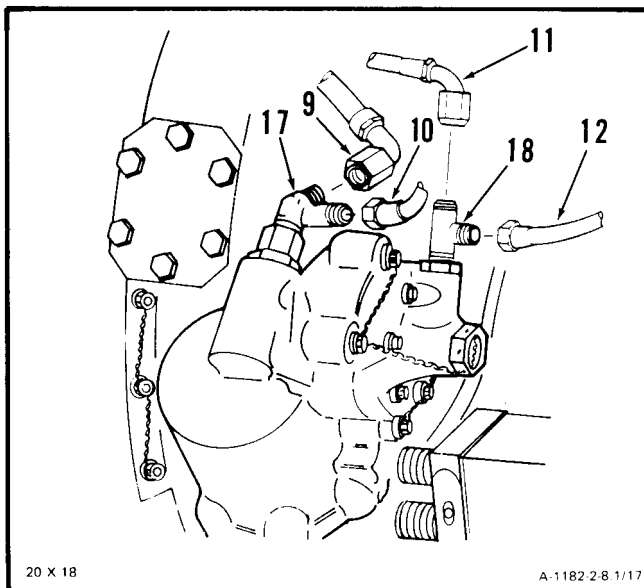

22. Connect two coil and cable assembly leads (3) to ignition exciter output receptacles (8). Lockwire lead connectors. Use lockwire (E29).

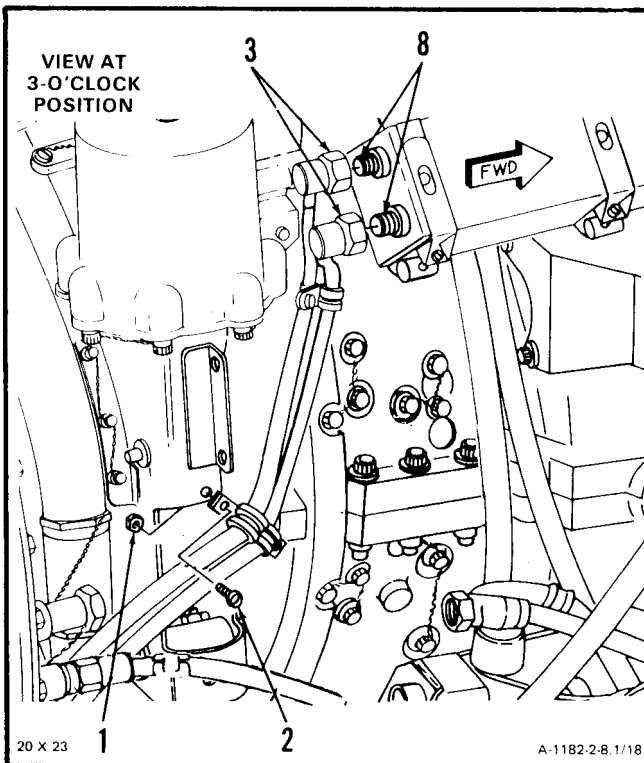

23. Install screw (2) and nut (1).

INSPECT

GO TO NEXT PAGE

**2-8.1 ADJUST INTERSTAGE AIR-BLEED ACUATOR (WITH WATER WASH KIT
P/N 2-200-071-54 INSTALLED) (Continued)**

2-8.1

FOLLOW-ON MAINTENANCE:

If Removed, Install Oil Cooler Assembly
(Task 8-11).

Perform Bleed Band Closure Check
(Task 1-107).

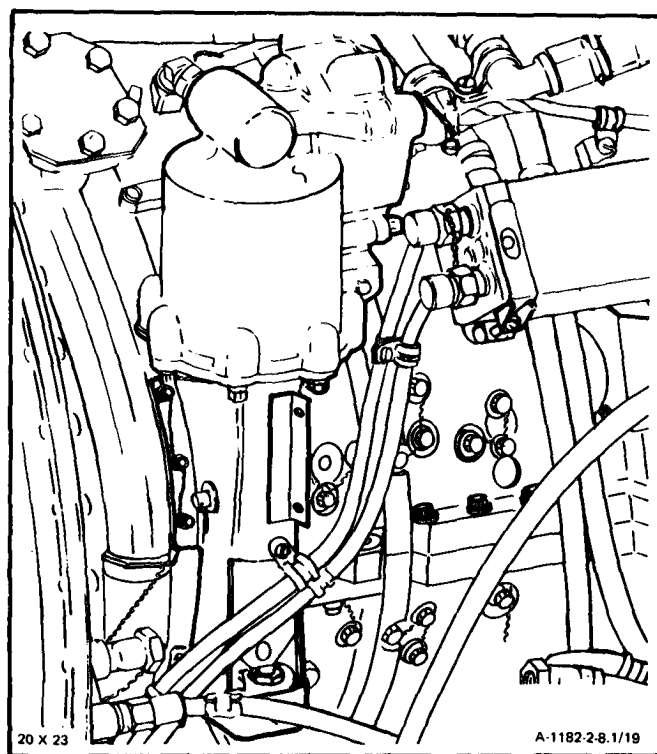

END OF TASK

Section II. COMPRESSOR BLEED BAND - MAINTENANCE PROCEDURES

2-9 REMOVE COMPRESSOR BLEED BAND

2-9

INITIAL SETUP

Applicable Configurations:

All

Tools:

None

Materials:

None

Personnel Required:

68B10 Aircraft Powerplant Repairer (2)

Equipment Condition:

Oil Cooler Assembly Removed (Task 8-5)

Interstage Air-Bleed Actuator Removed
(Task 2-1)

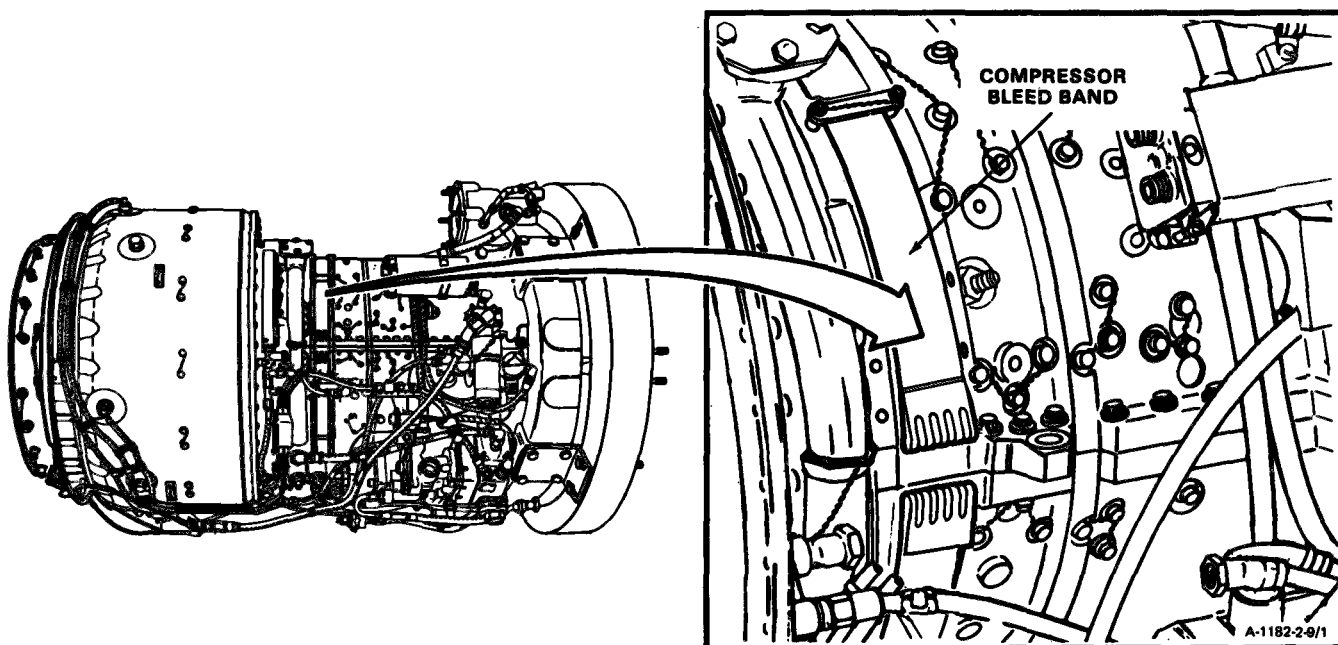

GO TO NEXT PAGE

2-9 REMOVE COMPRESSOR BLEED BAND (Continued)

CAUTION

The bleed band is very thin and bends easily. Be careful not to kink or bend it during handling. If kinked or bent, bleed band must be replaced.

1. Pull lower end (1) of bleed band (2) until trailing end (3) reaches first of five retainers (4).

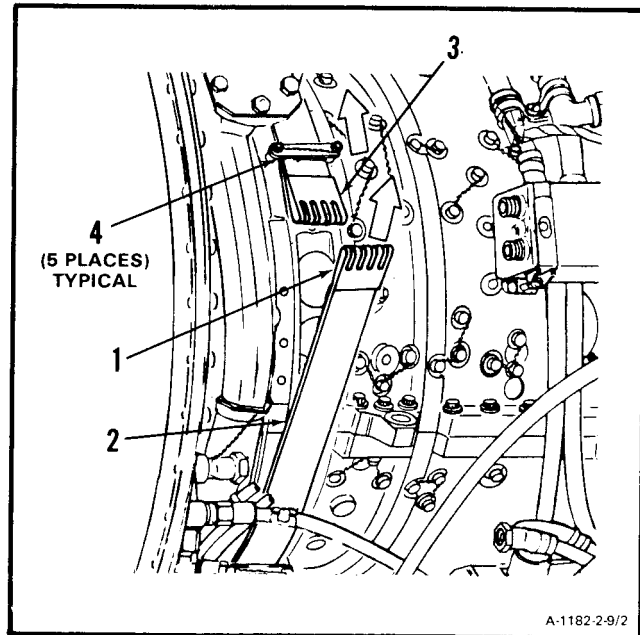

2. Continue pulling bleed band (2). Have helper guide trailing end (3) through five retainers (4).

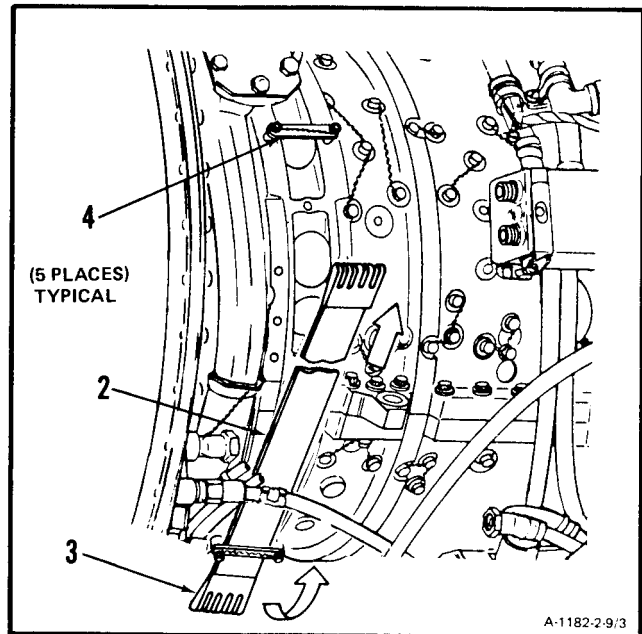

GO TO NEXT PAGE

3. Remove bleed band (2).

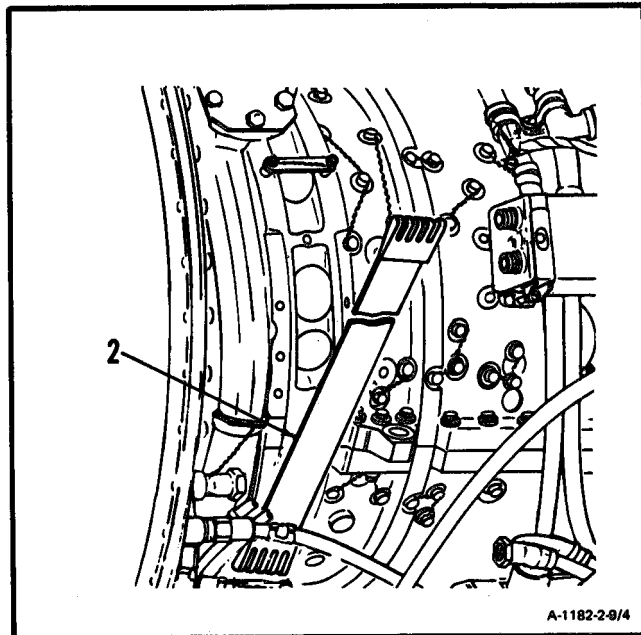

FOLLOW-ON MAINTENANCE:

None

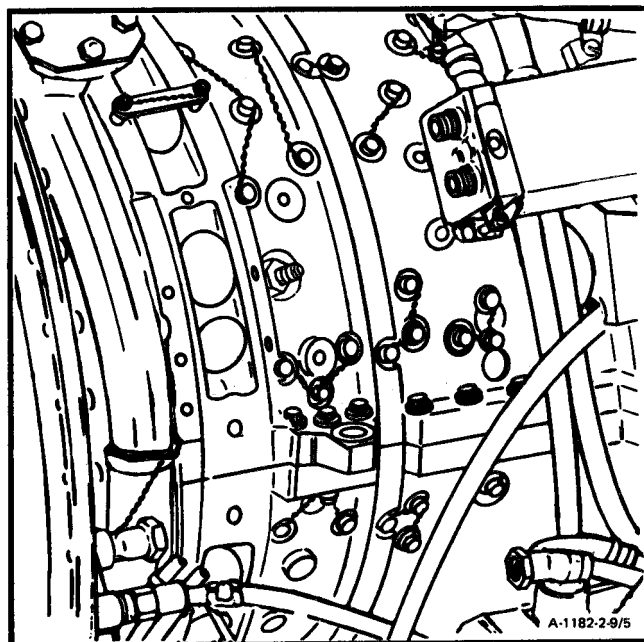

END OF TASK

2-10 CLEAN COMPRESSOR BLEED BAND

2-10

INITIAL SETUP

General Safety Instructions:**Applicable Configurations:**

All

Tools:

None

Materials:

Dry Cleaning Solvent (E17)
Gloves (E20)
Lint-Free Cloth (E26)

Personnel Required:

68B10 Aircraft Powerplant Repairer

Equipment Condition:

Off Engine Task
Oil Cooler Assembly Removed (Task 8-5)
Interstage Air-Bleed Actuator Removed
(Task 2-1)
Compressor' Bleed Band Removed (Task 2-9)

WARNING

Dry cleaning solvent (E17) is flammable and toxic. It can irritate skin and cause burns. Use only in well-ventilated area, away from heat and open flame. In case of contact, immediately flush skin or eyes with water for at least 15 minutes. Get medical attention for eyes.

CAUTION

The bleed band is very thin and bends easily. Be careful not to kink or bend it during handling. If kinked or bent, bleed band must be replaced.

1. Wear gloves (E20). **Clean bleed band (1)** with clean lint-free cloth (E26) dampened in dry cleaning solvent (E17).
2. **Remove residue from band ends** with clean, dry lint-free cloth (E26) after cleaning.

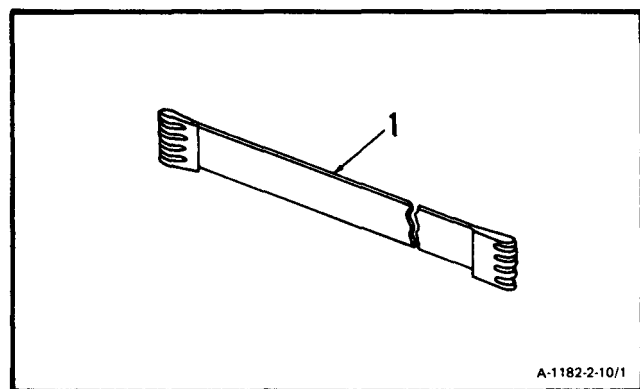

A-1182-2-10/1

FOLLOW-ON MAINTENANCE:

Inspect Compressor Bleed Band (Task 2-11).

END OF TASK

2-11 INSPECT COMPRESSOR BLEED BAND

2-11

INITIAL SETUP**Applicable Configurations:**

All

Tools:Technical Inspection Tool Kit,
NSN 5180-00-323-5114**Materials:**

None

Personnel Required:

68B30 Aircraft Powerplant Inspector

References:

Task 2-12

Equipment Condition:

Off Engine Task

CAUTION

The bleed band is very thin and bends easily. Be careful not to kink or bend it during handling. If kinked or bent, bleed band must be replaced.

1. Inspect bleed band (1).

- a. There shall be no cracks or distortion.
- b. There shall be no edge wear deeper than 0.100 inch on either side over entire length. **Repair edge wear up to 0.100 inch deep** (Ref. Task 2-12).
- c. There shall be no scratches deeper than 30 percent of band thickness. There shall be no scratches that cause band to be deformed.

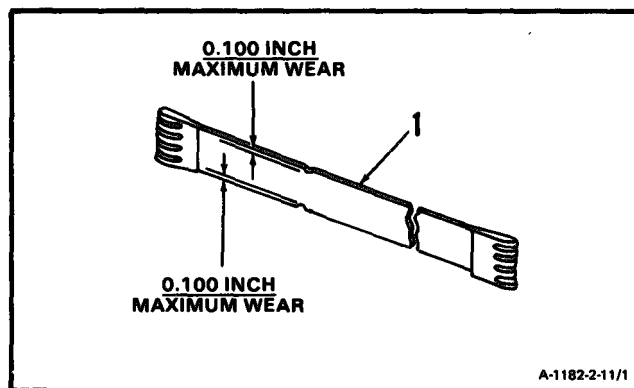
**FOLLOW-ON MAINTENANCE:**

None

END OF TASK

2-12 REPAIR COMPRESSOR BLEED BAND

2-12

INITIAL SETUP**Applicable Configurations:**

All

Tools:

Technical Inspection Tool Kit.
NSN 5180-00-323-5114
Hand File Set

Materials/Parts:

Carborundum Stone (E 11)
Crocus Cloth (E16)
Perchloroethylene (E-68)
Isopropyl Alcohol (E-69)
Fluorescent-Penetrant Materials (E73),
Appendix C

Personnel Required:

68B10 Aircraft Powerplant Repairer
68B30 Aircraft Powerplant Inspector

References:

TM 1-1500-335-23

Equipment Condition:

Off Engine Task

CAUTION

The bleed band is very thin and bends easily. Be careful not to kink or bend it during handling. If kinked or bent, bleed band must be replaced.

1. Repair edge wear up to 0.100 inch deep, on bleed band (1) as follows:

NOTE

Repair is allowed only if depth after repair is not more than 0.100 inch.

- a. **Blend-repair** to a smooth contour using carborundum stone (E11).
- b. **Remove burrs** around repair from both sides of band. Use file.
- c. **Final polish** area with crocus cloth (E16).
- d. **Fluorescent-penetrant inspect** per paragraph 2-12.1.3, repaired area (Ref. TM 1-1500-335-23).
- e. Parts requiring fluorescent penetrant inspection shall be cleaned using perchloroethylene (item E-68, appendix C) to remove surface contamination. Parts must be visibly dry prior to application of penetrant. To facilitate drying, parts may be wiped with isopropyl alcohol (item E-69, appendix C) or dried with air circulation at 130°F for a minimum of five minutes.

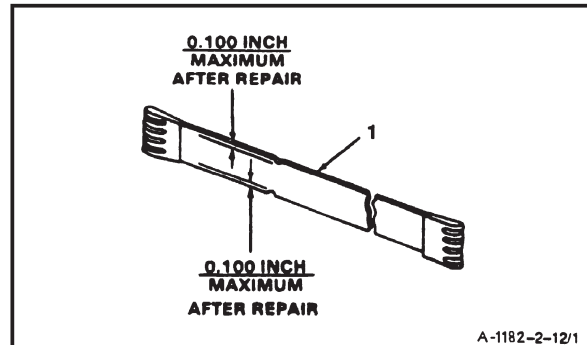
**INSPECT**

FOLLOW-ON MAINTENANCE
None

END OF TASK

2-13 INSTALL COMPRESSOR BLEED BAND

2-13

INITIAL SETUP**Applicable Configurations:**

All

Tools:Technical Inspection Tool Kit,
NSN 5180-00-323-5114**Materials:**

None

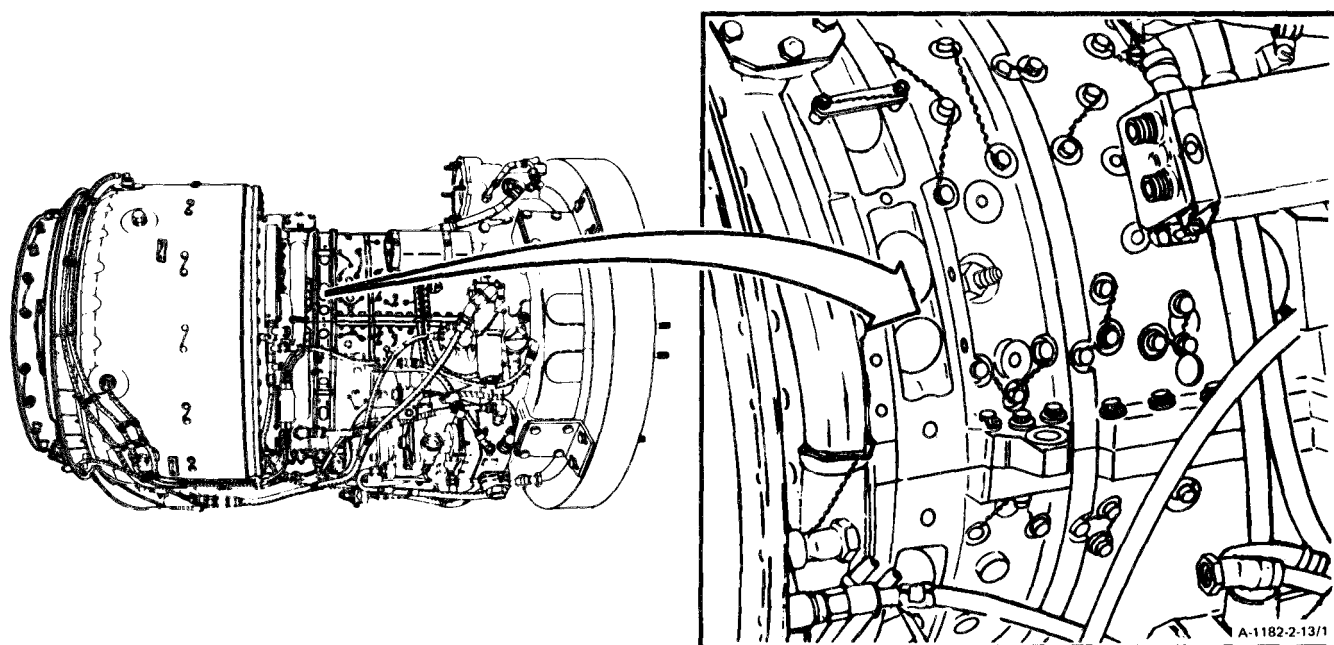
Personnel Required:68B10 Aircraft Powerplant Repairer
68B30 Aircraft Powerplant Inspector**GO TO NEXT PAGE**

CAUTION

The bleed band is very thin and bends easily. Be careful not to kink or bend it during handling. If kinked or bent, bleed band must be replaced.

1. Locate retainer (1) and align bleed band (2) with it.

NOTE

Welded lap must face away from engine.

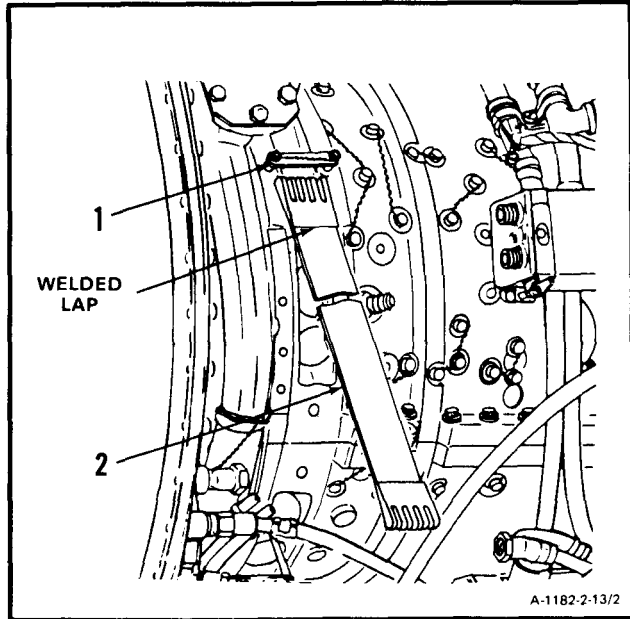

2. Position end of bleed band (2) under and through retainer (1).

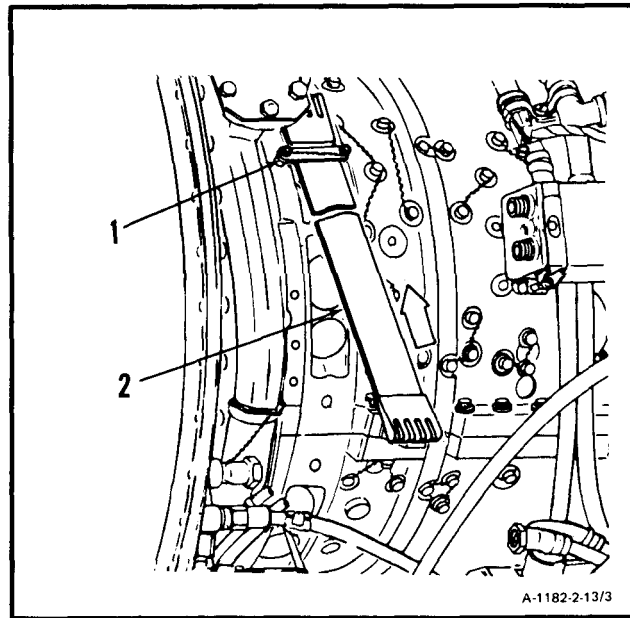

GO TO NEXT PAGE

2-13 INSTALL COMPRESSOR BLEED BAND (Continued)

2-13

3. Slide bleed band (2) up and over compressor housing (3) and through two retainers (4).

4. Continue sliding bleed band (2) around compressor housing (3). Guide it between fuel control (5) and compressor housing (3).

5. Continue sliding bleed band (2) around compressor housing (3). **Install bleed band (2) under and through two retainers (6) and into position shown.**

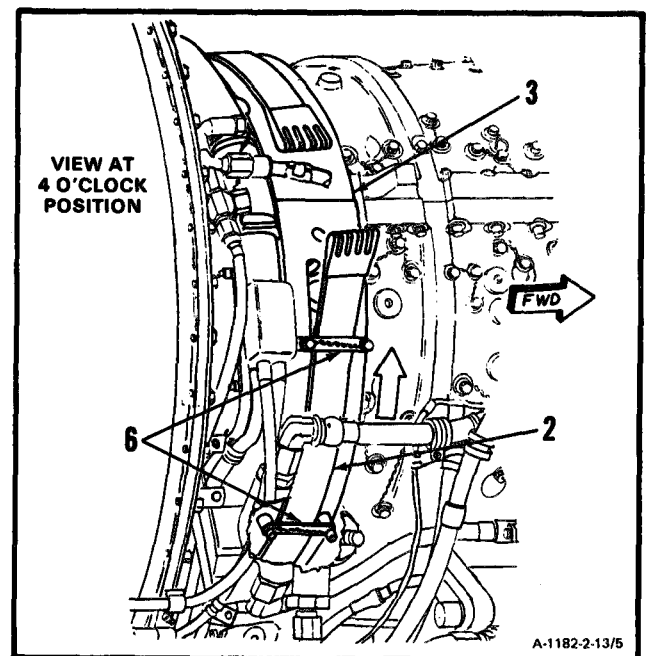
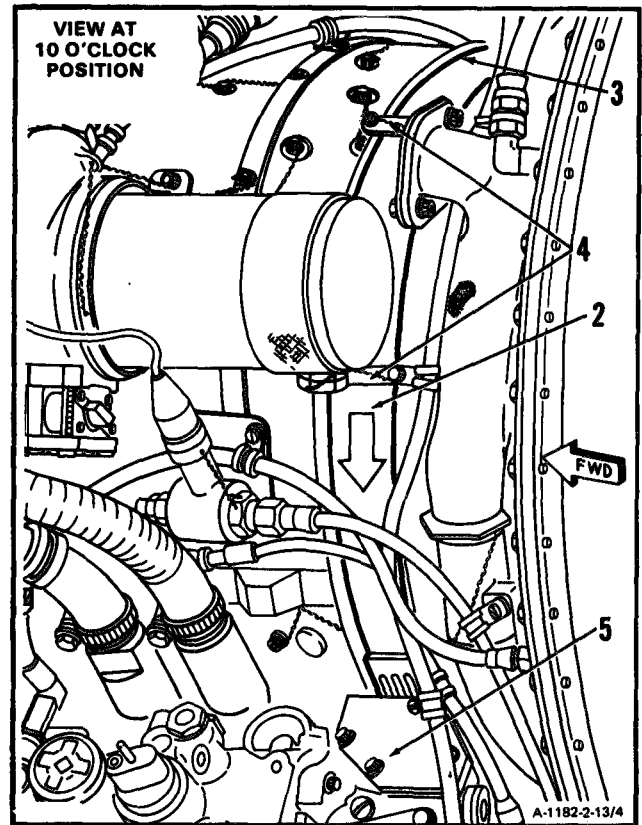

INSPECT

GO TO NEXT PAGE

FOLLOW-ON MAINTENANCE:

Install Interstage Air-Bleed Actuator (Task 2-7).

Install Oil Cooler Assembly (Task 8-11).

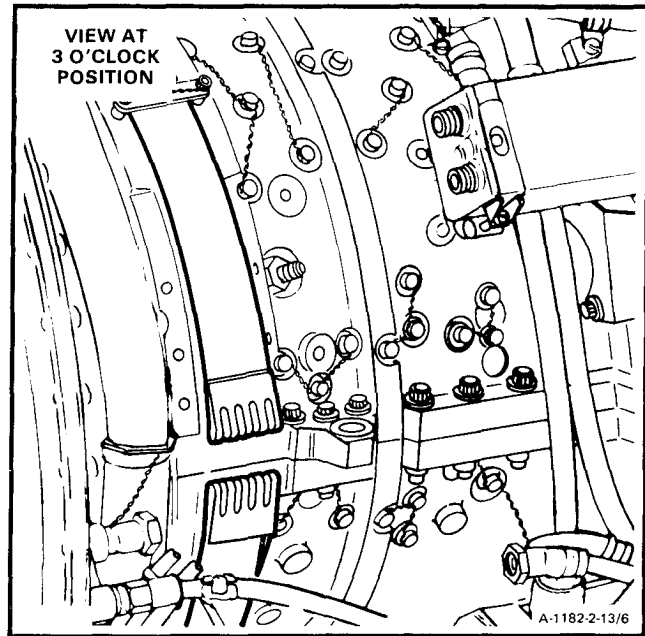

END OF TASK

2-14 REMOVE ANTI-ICING AIR GALLERY COVER

2-14

INITIAL SETUP

Applicable Configurations:

All

Tools:

Powerplant Mechanic's Tool Kit,
NSN 5180-00-323-4944
Padded Conduit Pliers

Materials:

None

Personnel Required:

68B10 Aircraft Powerplant Repairer

Equipment Condition:

Oil Cooler Assembly Removed (Task 8-5)
Interstate Air-Bleed Actuator Removed
(Task 2-1)
Dual Chip Detector Removed (Task 8-28)
Fuel Control Removed (Task 6-1)
Main Fuel Filter and Bracket Removed
(Task 6-29)

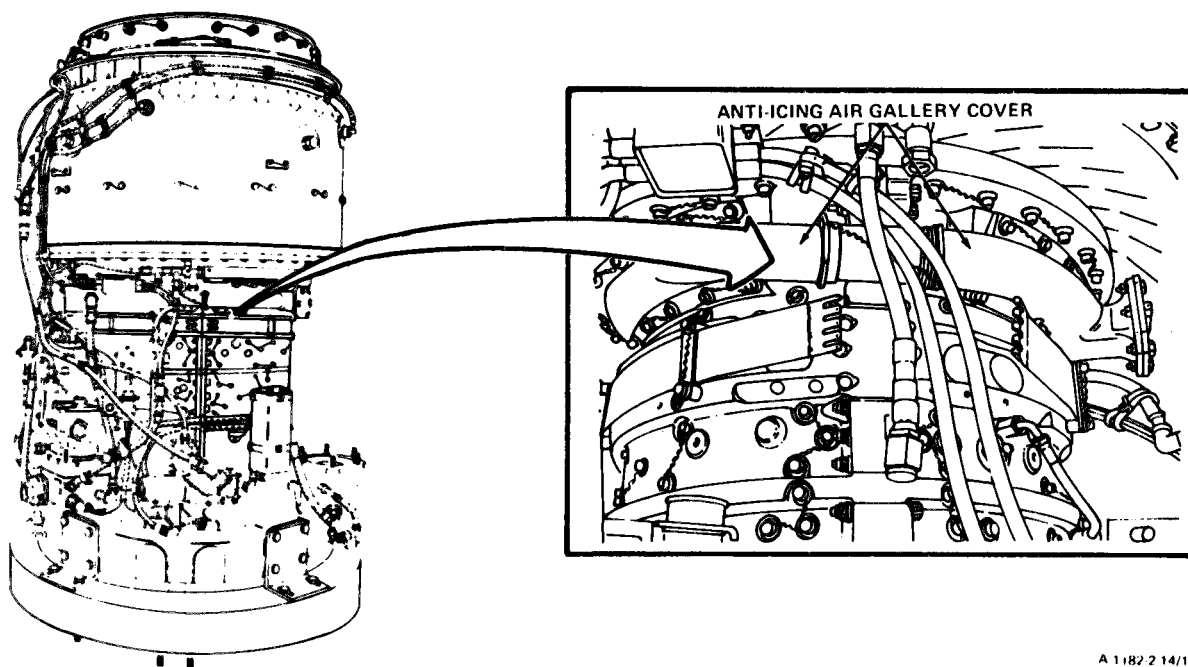

A 1182 2 14/1

GO TO NEXT PAGE

2-14 REMOVE ANTI-ICING AIR GALLERY COVER (Continued)

2-14

NOTE

Step 1. applies to connectors at both 3- and 9-o'clock positions. Connector at 3-o'clock position is shown.

NOTE

Do not remove nuts from connector.

1. Remove lockwire and **loosen two nuts (1) on connector (2)**. Use padded conduit pliers.
2. **Disconnect hose assembly (3)**.
3. **Remove lockwire and two bolts (4)**.

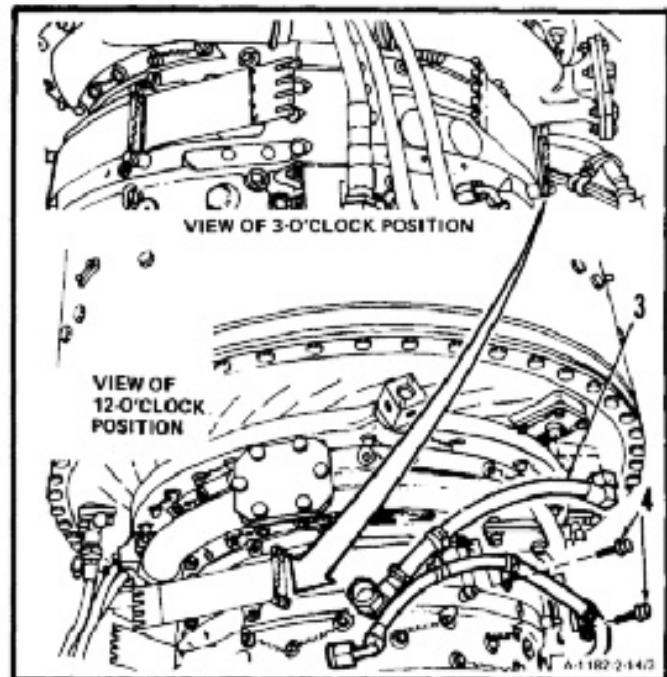
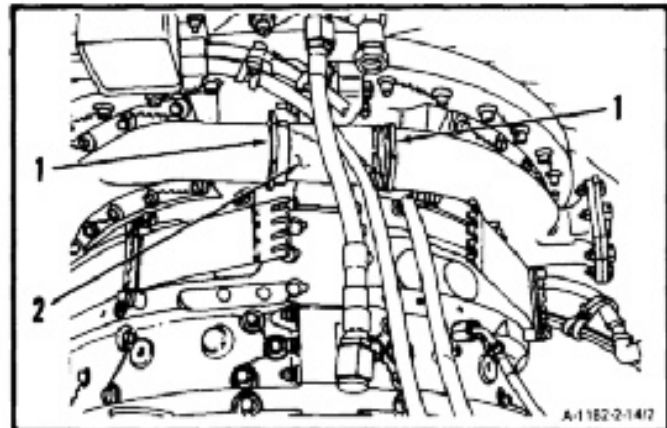

4. **Remove lockwire, 23 bolts (5), and washers (6)**.
5. **Remove anti-icing gallery cover upper half (7) and gasket (8)**.

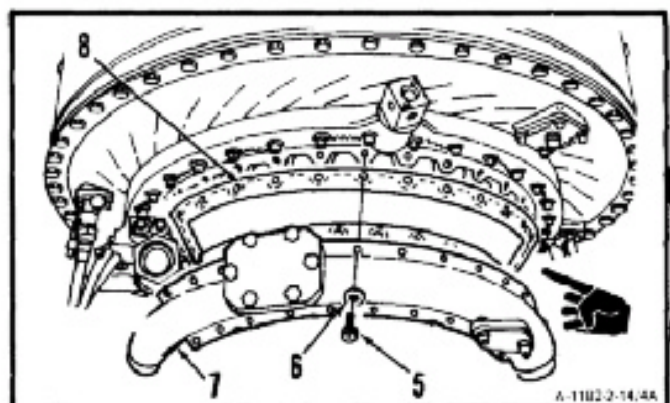

GO TO NEXT PAGE

2-14 REMOVE ANTI-ICING AIR GALLERY COVER (Continued)

2-14

NOTE

Steps 6. and 7. apply to connectors at both 3- and 9-o'clock positions. Connector at 3-o'clock position is shown.

6. **Remove connector (2)** with two nuts (1) installed.
7. **Remove two nuts (1)** spacers (9), and retainers (10) from connector (2).

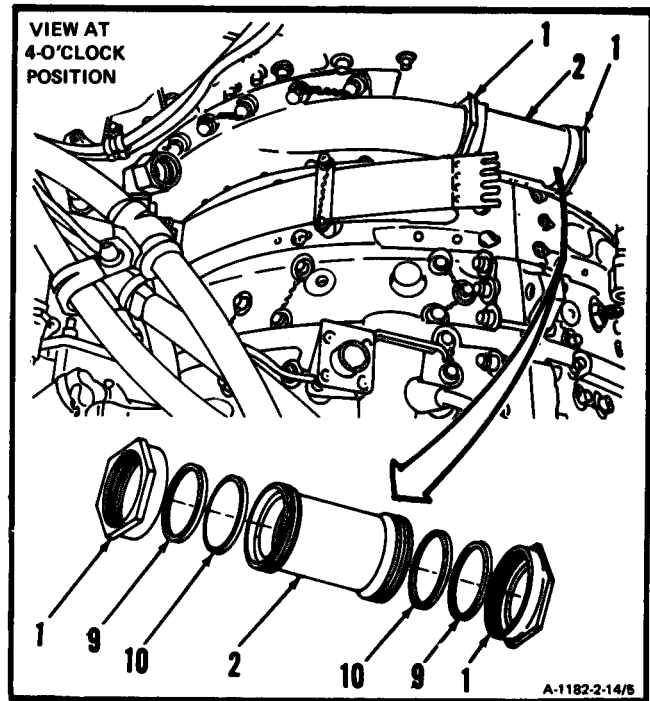

8. **Remove lockwire, 23 bolts (11),** and two strips (12 and 13).
9. **Remove air gallery cover lower half (14)** and gasket (15).

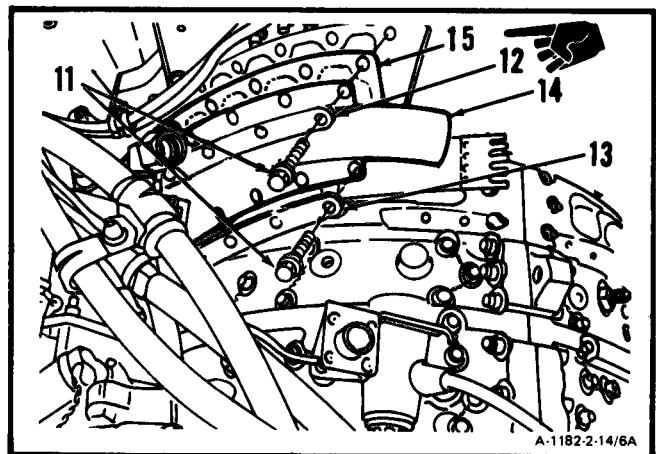

GO TO NEXT PAGE

FOLLOW-ON MAINTENANCE:

None

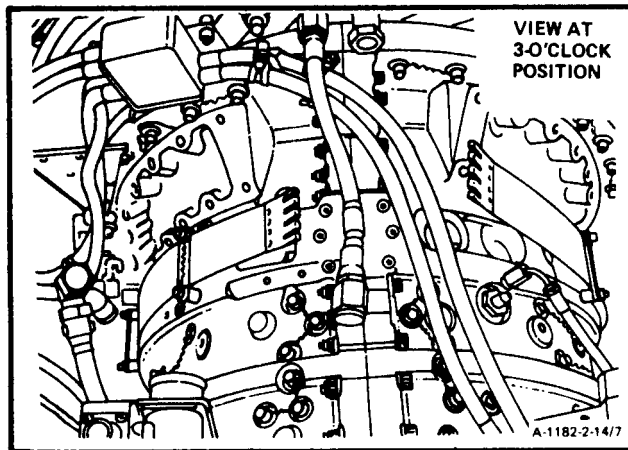

END OF TASK

2-15 CLEAN ANTI-ICING AIR GALLERY COVER

2-15

INITIAL SETUP**General Safety Instructions:****Applicable Configurations:**

All

Tools:

Powerplant Mechanic's Tool Kit,
NSN 5180-00-323-4944
Putty Knife

Materials:

Dry Cleaning Solvent (E17)
Gloves (E20)
Lint-Free Cloth (E26)

Personnel Required:

68B10 Aircraft Powerplant Repairer

Equipment Condition:

Off Engine Task
Oil Cooler Assembly Removed (Task 8-5)
Interstage Air-Bleed Actuator Removed
(Task 2-1)
Dual Chip Detector Removed (Task 8-28)
Fuel Control Removed (Task 6-1)
Main Fuel Filter and Bracket Removed
(Task 6-29)
Anti-Icing Air Gallery Cover Removed
(Task 2-14)

WARNING

Dry cleaning solvent (E17) is flammable and toxic. It can irritate skin and cause burns. Use only in well-ventilated area, away from heat and open flame. In case of contact, immediately flush skin or eyes with water for at least 15 minutes. Get medical attention for eyes.

GO TO NEXT PAGE

1. Wear gloves (E20). **Clean anti-icing air gallery cover upper half (1) and lower half (2).** Use lint-free cloth (E26) dampened in dry cleaning solvent (E17). Use putty knife to remove gasket material from sealing surfaces (3). Use brush to clean inside surfaces (4).

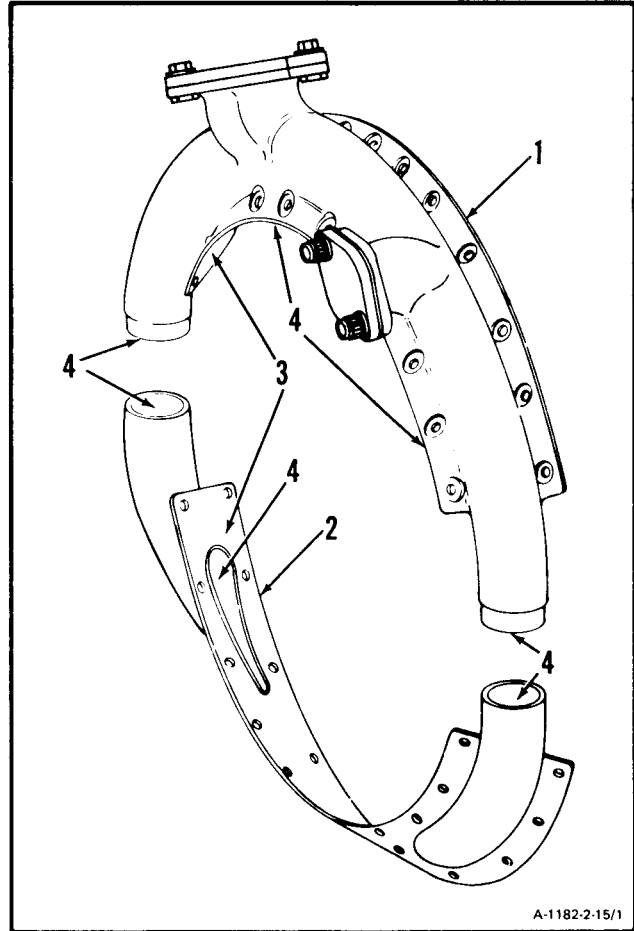

GO TO NEXT PAGE

2. Clean two connectors (5), four nuts (6), four spacers (7), four retainers (8) and two strips (9). Use lint-free cloth (E26) dampened in dry cleaning solvent (E17). Use brush to clean inside surfaces (10).

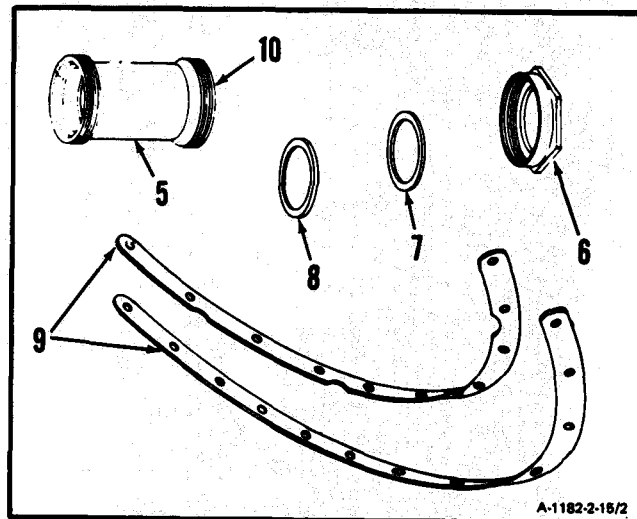

FOLLOW-ON MAINTENANCE:

Inspect Anti-Icing Air Gallery Cover (Task 2-16).

END OF TASK

INITIAL SETUP

Applicable Configurations:

All

Tools:

Technical Inspection Tool Kit,
NSN 5180-00-323-5114

Materials:

None

Personnel Required:

68B30 Aircraft Powerplant Inspector

Equipment Condition:

Off Engine Task

1. Inspect anti-icing air gallery cover upper half (1).

- a. There shall be no cracks or corrosion.
- b. There shall be no gouges or chafes deeper than 0.030 inch in cover (2). Any length or width gouge or chafe is acceptable.
- c. There shall be no gouges or chafes deeper than 0.015 inch in tubes (3). Any length or width gouge or chafe is acceptable.
- d. There shall be no two gouges or chafes closer to each other than 1 -inch.

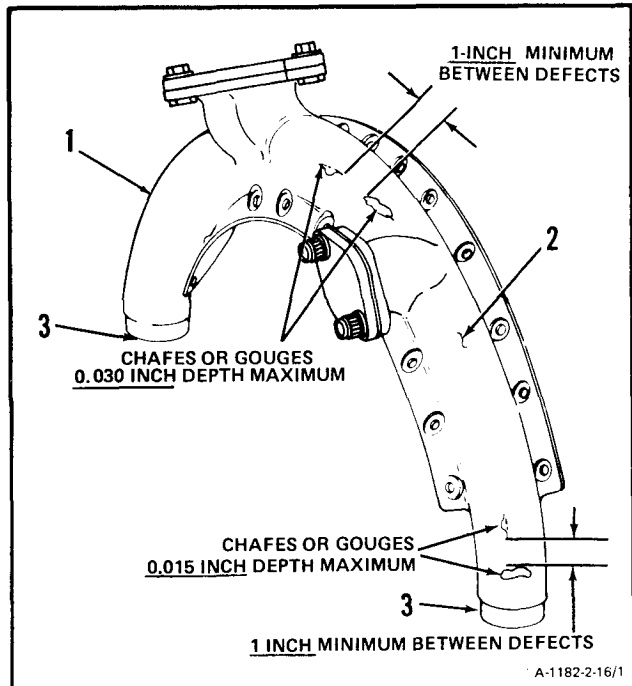

GO TO NEXT PAGE

2. Inspect anti-icing air gallery cover lower half (4).

- a. There shall be no cracks.
- b. There shall be no gouges or chafes deeper than 0.030 inch in cover (5). Any length or width gouge or chafe is acceptable.
- c. There shall be no gouges or chafes deeper than 0.015 inch in tubes (6), Any length or width gouge or chafe is acceptable.
- d. There shall be no two gouges or chafes closer to each other than 1 -inch.

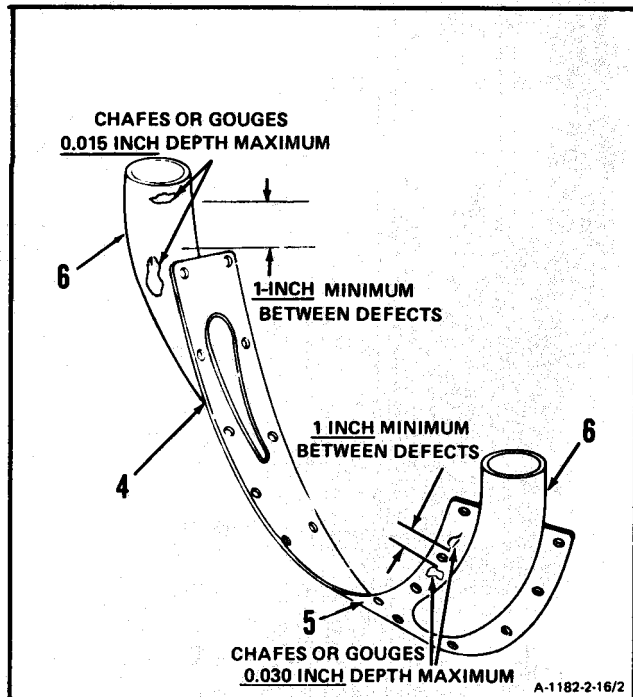

3. Inspect two connectors (7), four nuts (8), four spacers (9), four retainers (10) and two strips (11). There shall be no cracks.

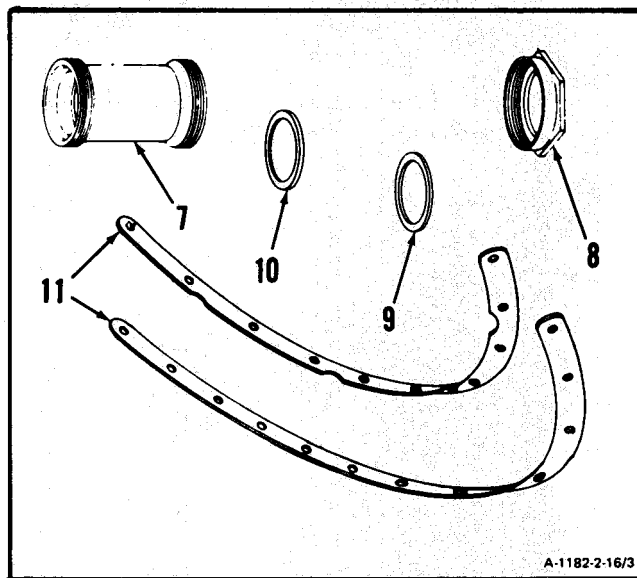

FOLLOW-ON MAINTENANCE:

None

END OF TASK

2-17 REPAIR ANTI-ICING AIR GALLERY COVER

2-17

INITIAL SETUP

Applicable Configurations:

All

Tools:

Technical Inspection Tool Kit,
NSN 5180-00-323-5114

Materials:

Acid Swabbing Brush (E2)
Carborundum Stone (E10)
Crocus Cloth (E15)
Engine Gray Enamel (E22)

Personnel Required:

68B10 Aircraft Powerplant Repairer
68B30 Aircraft Powerplant Inspector

References:

Task 1-119

Equipment Condition:

Off Engine Task

1. Repair anti-icing air gallery cover upper half (1).

- a. Repair gouges or chafes up to 0.015 inch deep on tubes (2). Blend repair. Use carborundum stone (E10) and crocus cloth (E15).
- b. Repair gouges or chafes up to 0.030 inch deep on cover (3). Blend repair. Use carborundum stone (E10) and crocus cloth (E15).
- c. Repair corroded surfaces or damaged paint. **Use engine gray enamel (E22)** (Ref. Task 1-119),

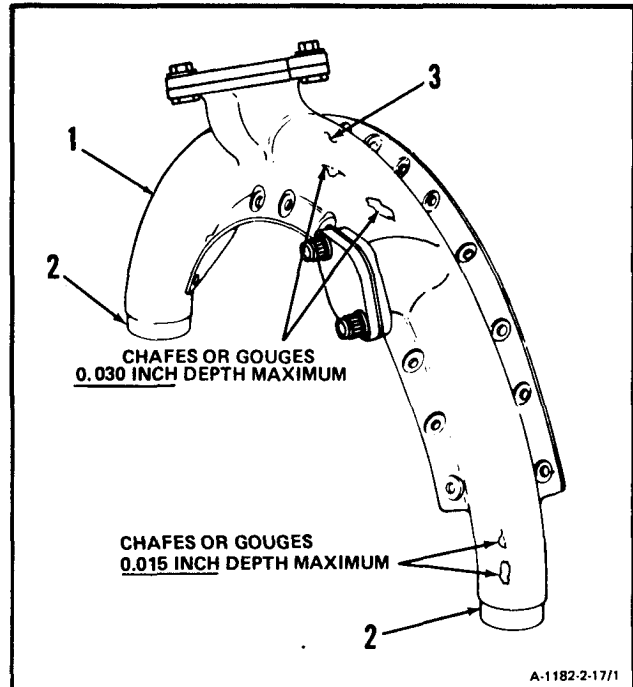
**GO TO NEXT PAGE**

2-17 REPAIR ANTI-ICING AIR GALLERY COVER (Continued)

2-17

2. Repair anti-icing air gallery cover lower half (4).

- a. Repair gouges or chafes up to 0.015 inch deep on tubes (5). Blend repair. Use carborundum stone (E10) and crocus cloth (E15).
- b. Blend repair gouges or chafes up to 0.030 inch deep on cover (6). Blend repair. Use Carborundum stone (E10) and crocus cloth (E15).
- c. Repair corroded surfaces or damaged paint. **Use engine gray enamel (E22)** (Ref. Task 1-119).

INSPECT**FOLLOW-ON MAINTENANCE**

None

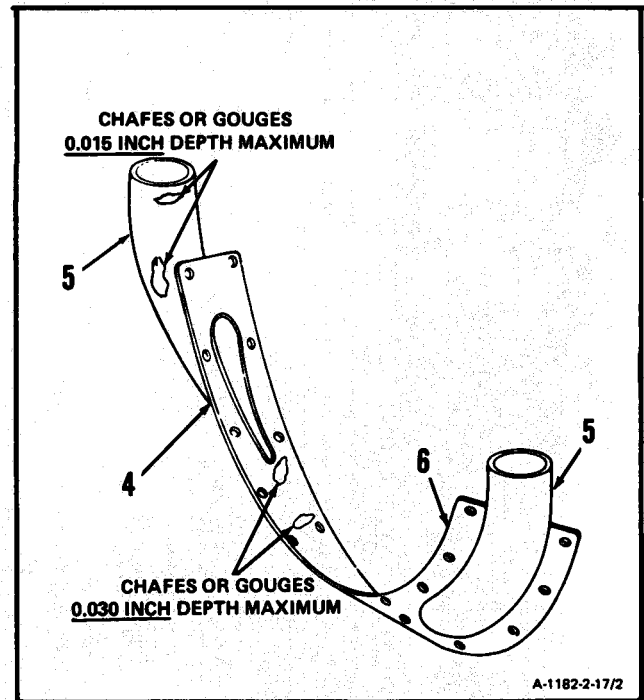
**END OF TASK**

2-18 INSTALL ANTI-ICING AIR GALLERY COVER

2-18

INITIAL SETUP**Applicable Configurations:**

All

Tools:

Powerplant Mechanic's Tool Kit,

NSN 5180-00-323-4944

Technical Inspection Tool Kit,

NSN 5180-00-323-5114

Torque Wrench, 30-150 Inch-Pounds

Crowfoot Attachment (T66)

Open-End Wrench, 1 -5/8 Inch

Materials:

Lockwire (E29)

Parts:

Gaskets

Seals

Personnel Required:

68B10 Aircraft Powerplant Repairer

68B30 Aircraft Powerplant Inspector

References:

TM 55-2840-254-23P

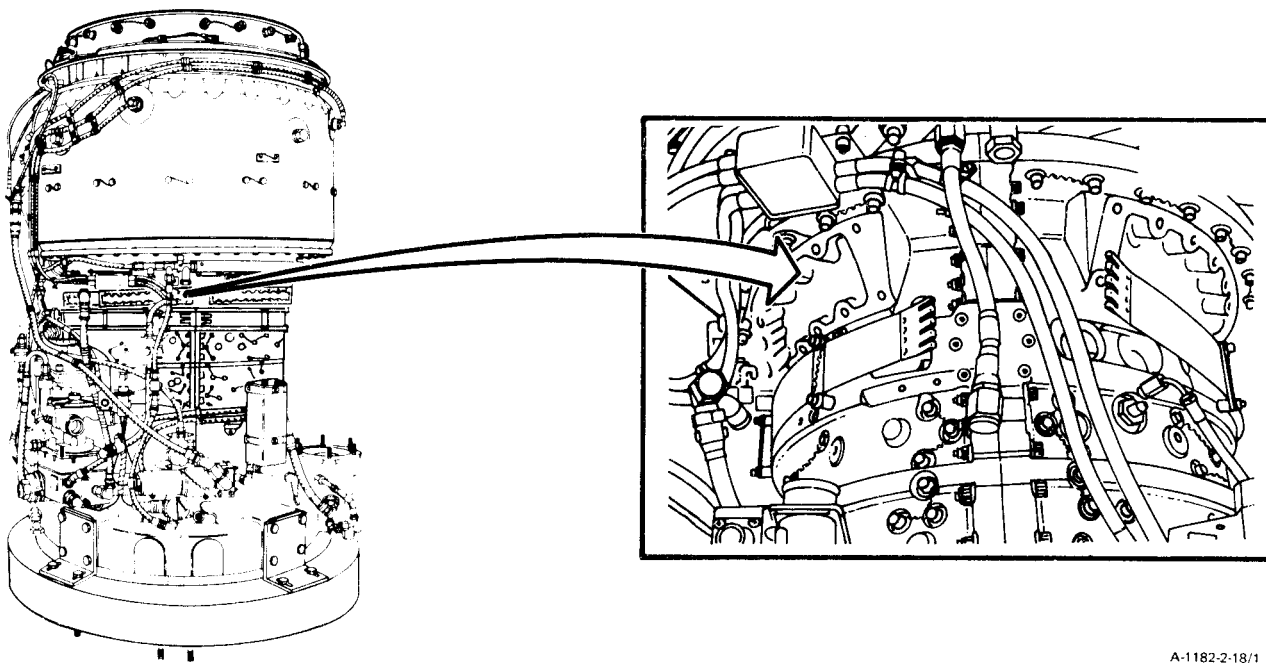

A-1182-2-18/1

GO TO NEXT PAGE

2-18 INSTALL ANTI-ICING AIR GALLERY COVER (Continued)**2-18****NOTE**

If anti-icing air gallery cover is a replacement, do steps 1. thru 4. If same anti-icing air gallery cover that was removed is to be installed, skip steps 1. thru 4.

1. **Remove six nuts (1), six bolts (2), cover (3), and gasket (4) from removed air gallery cover upper half (5).**

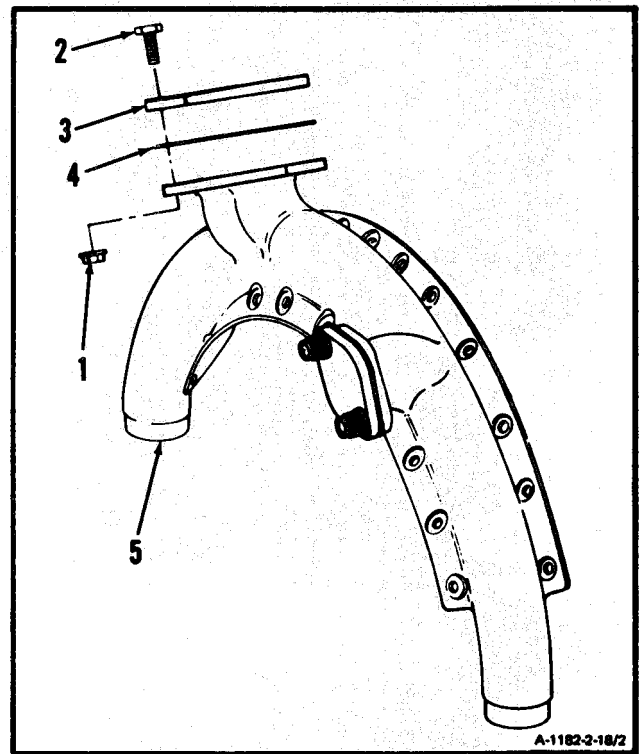
**GO TO NEXT PAGE**

2. Remove two nuts (6), two bolts (7), four washers (8), **cover (9)**, and gasket (10) from removed air gallery cover upper half (5).

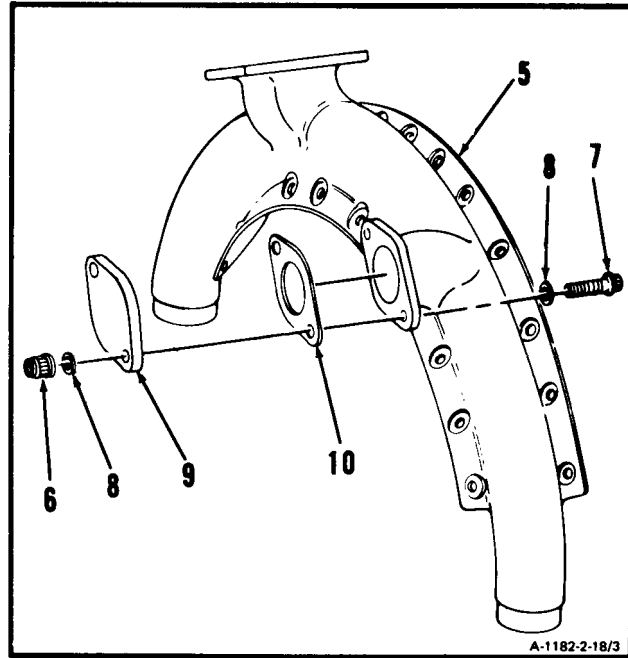

3. **Install** gasket (10), **cover (9)**, two bolts (7), four washers (8), and two nuts (6) on serviceable air gallery cover upper half (11).

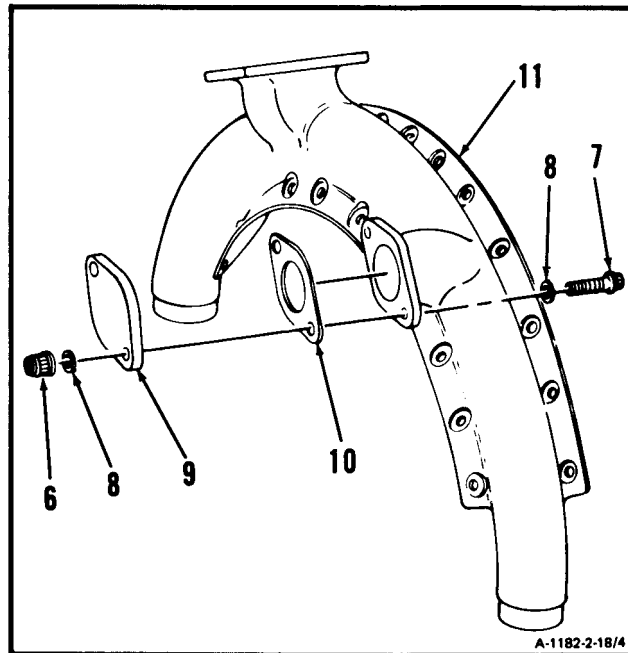

GO TO NEXT PAGE

2-18 INSTALL ANTI-ICING AIR GALLERY COVER (Continued)

2-18

4. **Install** gasket (4), **cover** (3), six bolts (2), and nuts (1) on serviceable air gallery cover upper half (11).

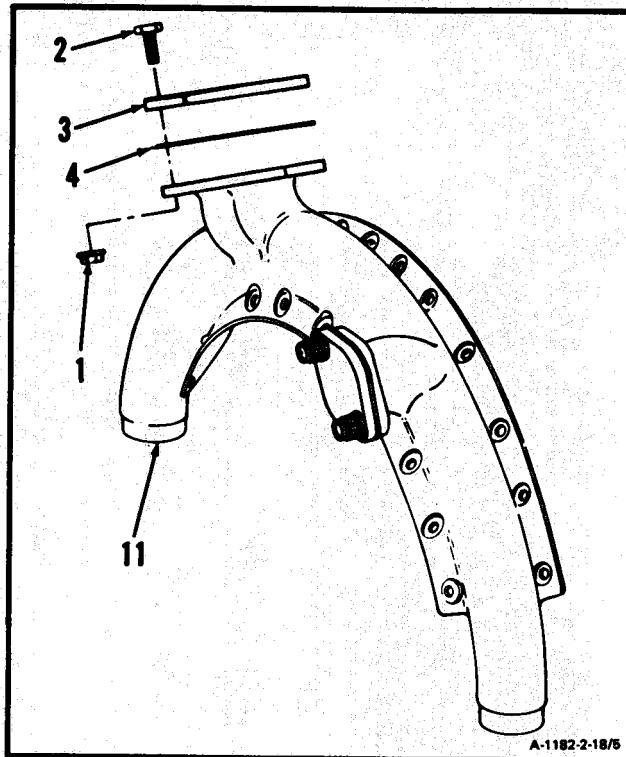

GO TO NEXT PAGE

2-18 INSTALL ANTI-ICING AIR GALLERY COVER (Continued)

2-18

NOTE

In following step, engage only two or three threads of 23 bolts.

5. **Install gasket (12), air gallery cover lower half (13), and strips (14 and 15) on compressor housing (16).** Loosely install 23 bolts (17).

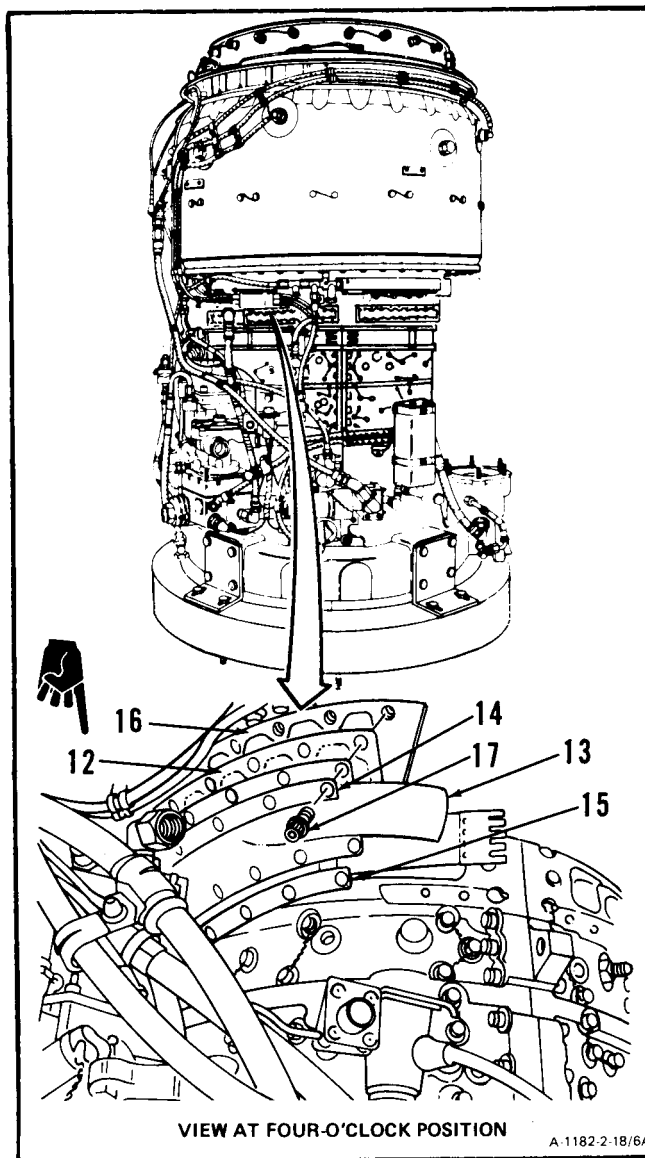

GO TO NEXT PAGE

2-18 INSTALL ANTI-ICING AIR GALLERY COVER (Continued)

2-18

NOTE

Steps 6. and 7. apply to connectors at each end of air gallery cover lower half (3- and 9-o'clock positions). Connector at 3-o'clock position is shown.

NOTE

When installing nuts on connector, engage about two threads only,

6. **Install** two retainers (18), spacers (19), and **nuts (20)** on connector (21).
7. **Install connectors (21)** on ends of air gallery cover lower half (13).
8. **Torque 23 bolts (17) to 85 inch-pounds** and lockwire. Use lockwire (E29).

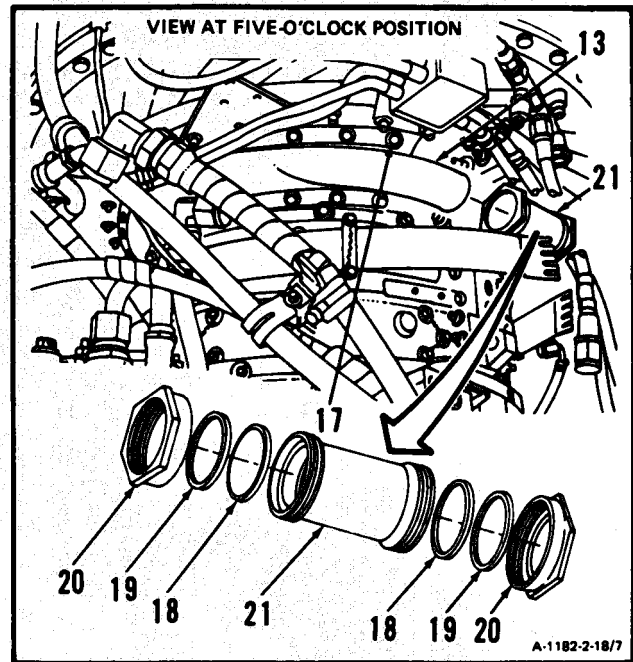

GO TO NEXT PAGE

2-18 INSTALL ANTI-ICING AIR GALLERY COVER (Continued)

9. **Install** gasket (22) and **air gallery cover upper half (11)** on compressor housing (16) with ends of air gallery cover upper half (11) in two connectors (21).

NOTE

In following step, engage only two or three threads of 23 bolts.

10. Loosely **install** 23 washers (23) and **bolts (24)**. **Torque bolts (24) to 85 inch-pounds** and lockwire. Use lockwire (E29).

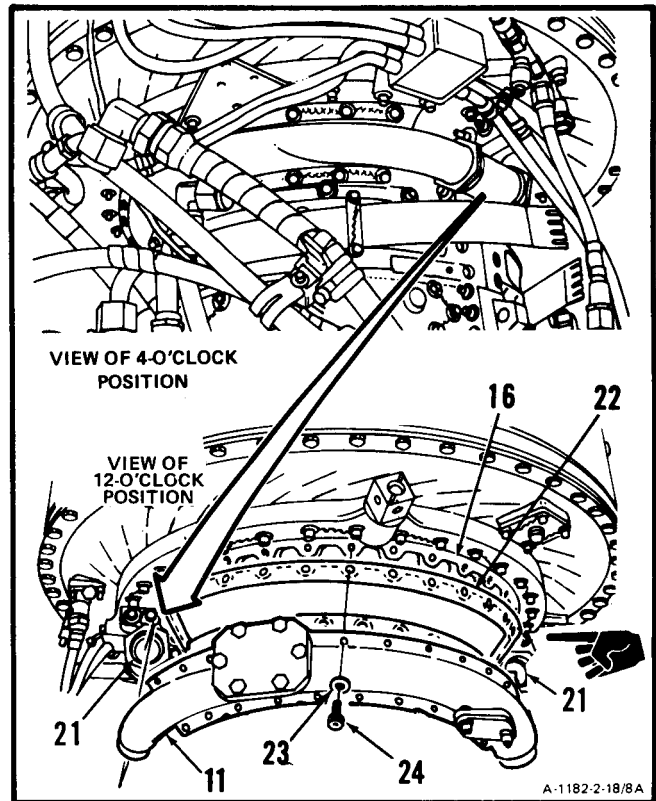

11. **Connect hose assembly (25)** to adapter (26).
12. **Install two bolts (27)** and lockwire. Use lockwire (E29).

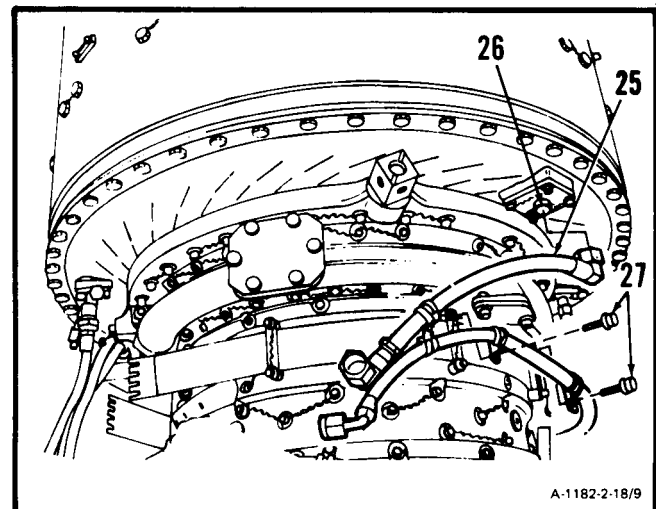

GO TO NEXT PAGE

2-18 INSTALL ANTI-ICING AIR GALLERY COVER (Continued)

2-18

NOTE

Step 12. applies to connectors at 3- and 9-o'clock positions. Connector at 3-o'clock position is shown.

13. **Torque two nuts (20) on connectors (21) to 90 inch-pounds.** Use crowfoot attachment (T66) and open-end wrench. Lockwire nuts (20). Use lockwire (E29).

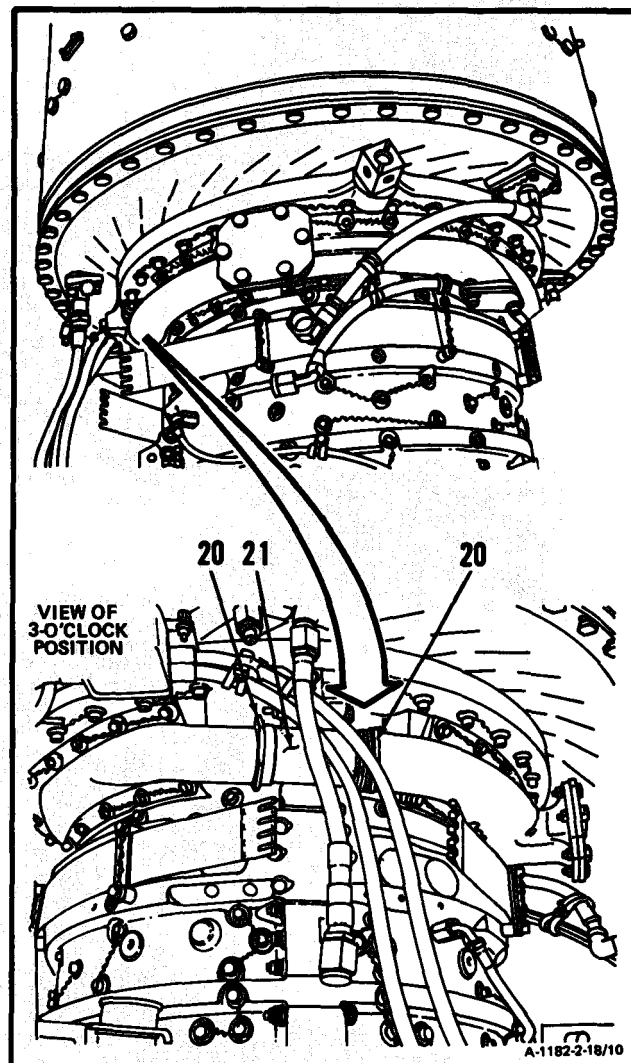
**INSPECT****GO TO NEXT PAGE**

FOLLOW-ON MAINTENANCE:

- Install Main Fuel Filter and Bracket (Task 6-35).
- Install Fuel Control (Task 6-6).
- Install Dual Chip Detector (Task 8-35).
- Install Interstate Air-Bleed Actuator (Task 2-7).
- Install Oil Cooler Assembly (Task 8-11).

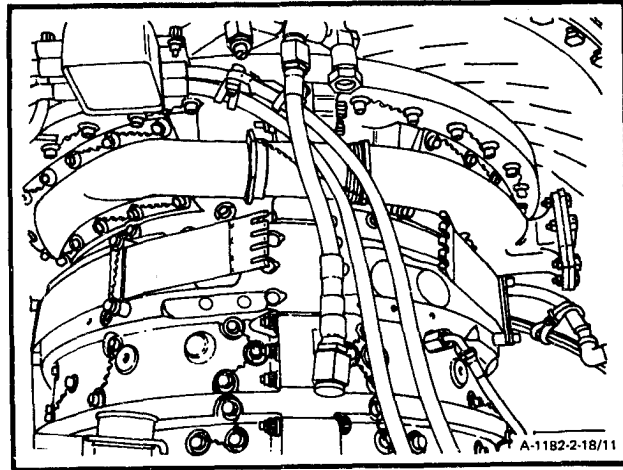
**END OF TASK**

Section IV. COMPRESSOR HOUSING - MAINTENANCE PROCEDURES

2-19 REMOVE UPPER COMPRESSOR HOUSING

2-19

INITIAL SETUP

Applicable Configurations:

All

Tools:

Powerplant Mechanic's Tool Kit,
NSN 5180-00-323-4944
Mechanical Puller (T6)
Padded Conduit Pliers

Materials:

None

Personnel Required:

68B10 Aircraft Powerplant Repairer (2)

Equipment Condition:

Engine Oil System Drained (Task 1-75)
Oil Cooler Assembly Removed (Task 8-5)
In-Line Fuel Filter Assembly Removed
(Task 6-36)
Ignition Exciter Removed (Task 7-11)
Oil Filler Assembly and Oil Filler Strainer
Removed (Task 8-16)
Starter Drive Removed (Task 5-12)
Main Fuel Filter and Bracket Removed
(Task 6-29)
Interstage Air-Bleed Actuator Removed
(Task 2-1)
Compressor Bleed Band Removed (Task 2-9)

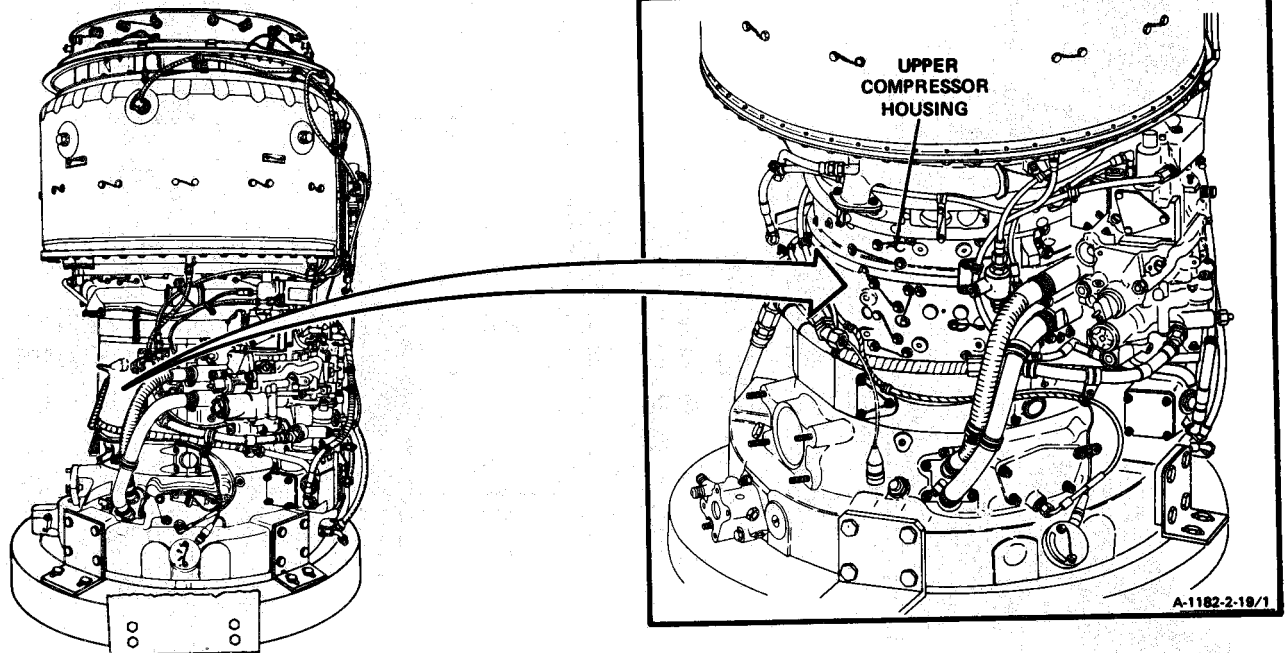

GO TO NEXT PAGE

CAUTION

When removing compressor housing, only upper or lower compressor housing half shall be removed at one time. At no time shall personnel attempt to remove both upper and lower compressor housing halves simultaneously, Failure to comply will cause engine damage,

1. Remove nut (1), bolt (2) and two clamps (3).

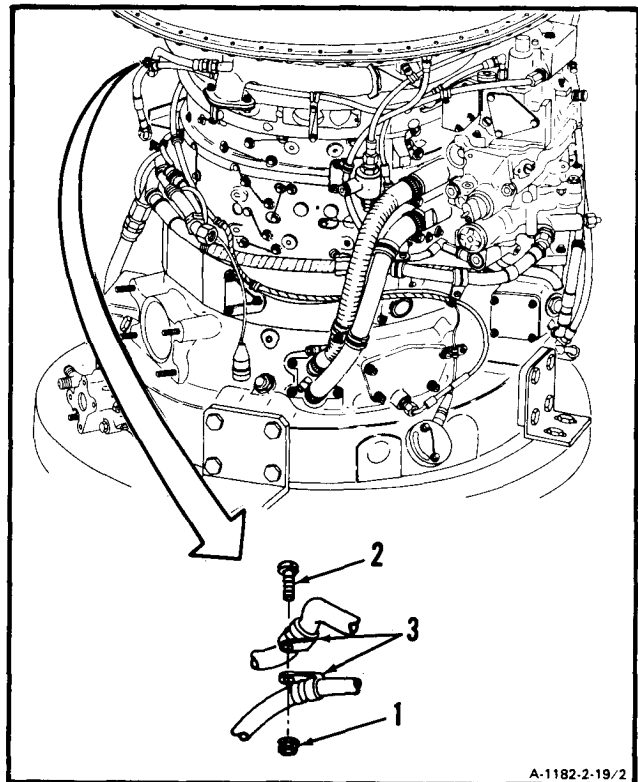

A-1182-2-19/2

GO TO NEXT PAGE

2-19 REMOVE UPPER COMPRESSOR HOUSING (Continued)

2-19

2. Disconnect and remove hose assembly (4) from adapter (5).

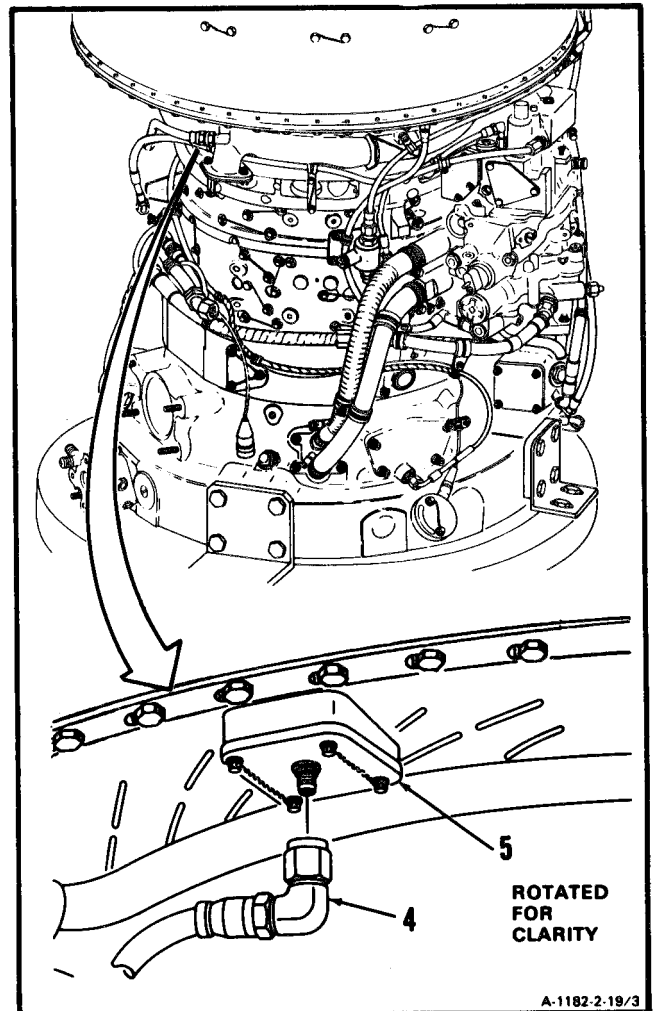

GO TO NEXT PAGE

3. **Remove** lockwire, four bolts (6), **adapter** (7), and packing (8).

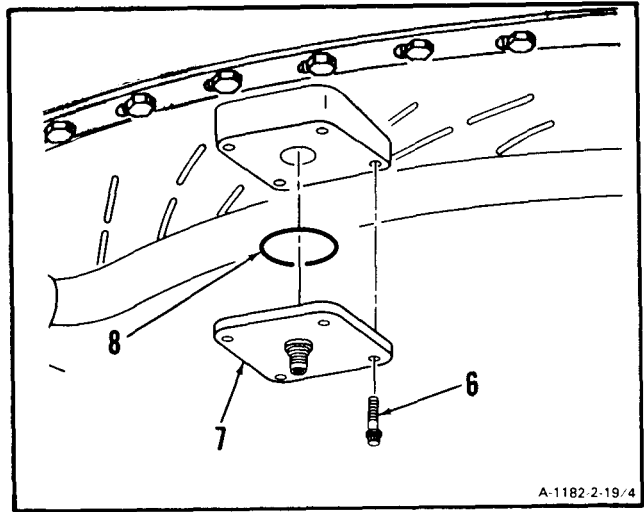

4. **Remove** lockwire, screw (9), and **clamp** (10).

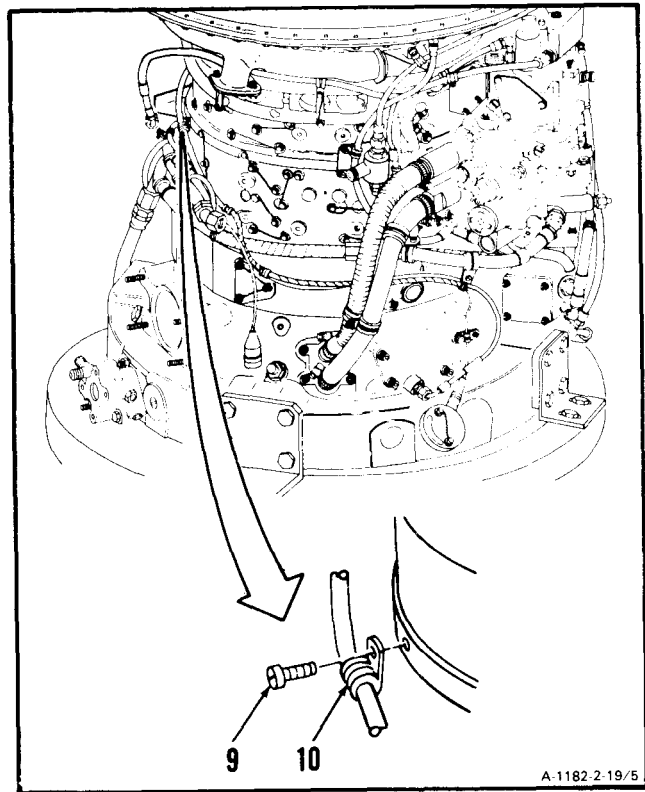

GO TO NEXT PAGE

2-19 REMOVE UPPER COMPRESSOR HOUSING (Continued)**2-19**

5. Remove lockwire, two bolts (11), and clamps (12).

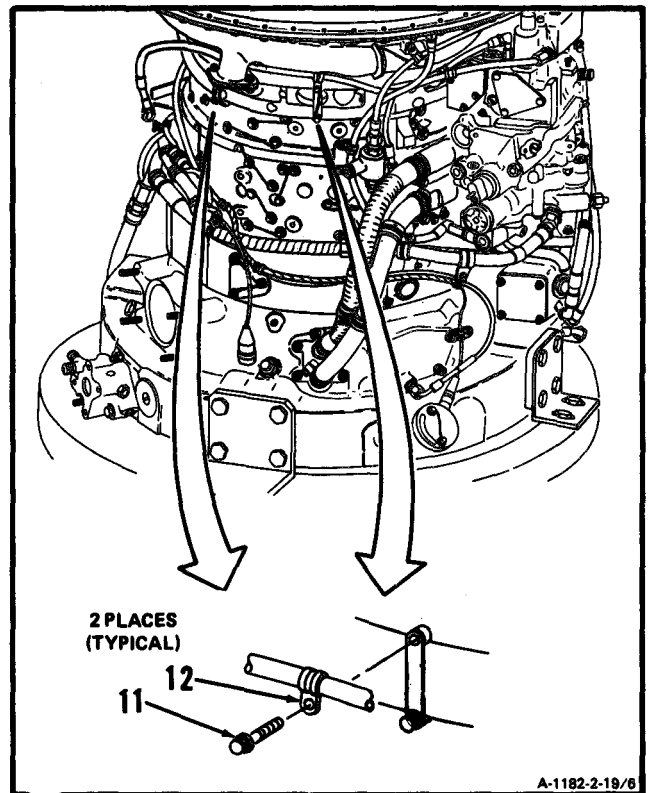

GO TO NEXT PAGE

6. **Disconnect hose assembly (13) from union (14).**

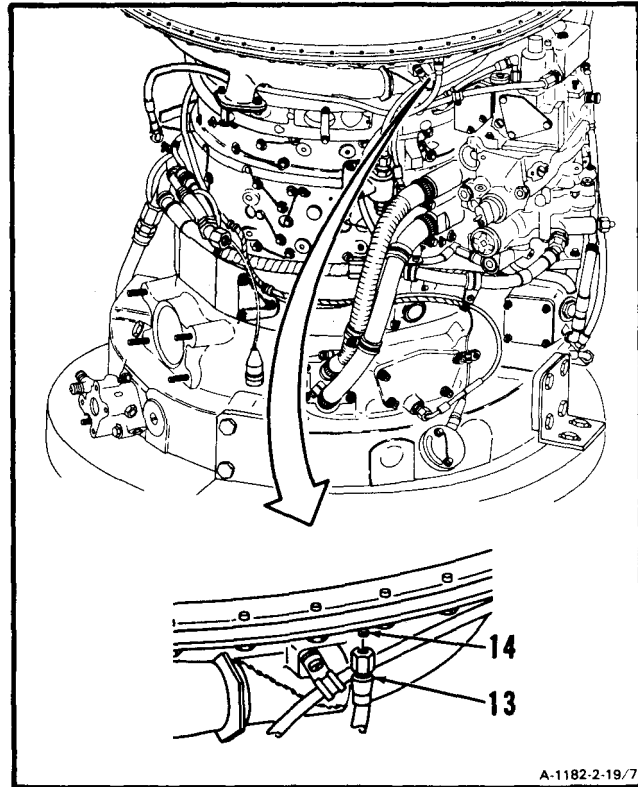

GO TO NEXT PAGE

2-19 REMOVE UPPER COMPRESSOR HOUSING (Continued)

2-19

7. **Disconnect hose assembly (13) from nipple (15).**

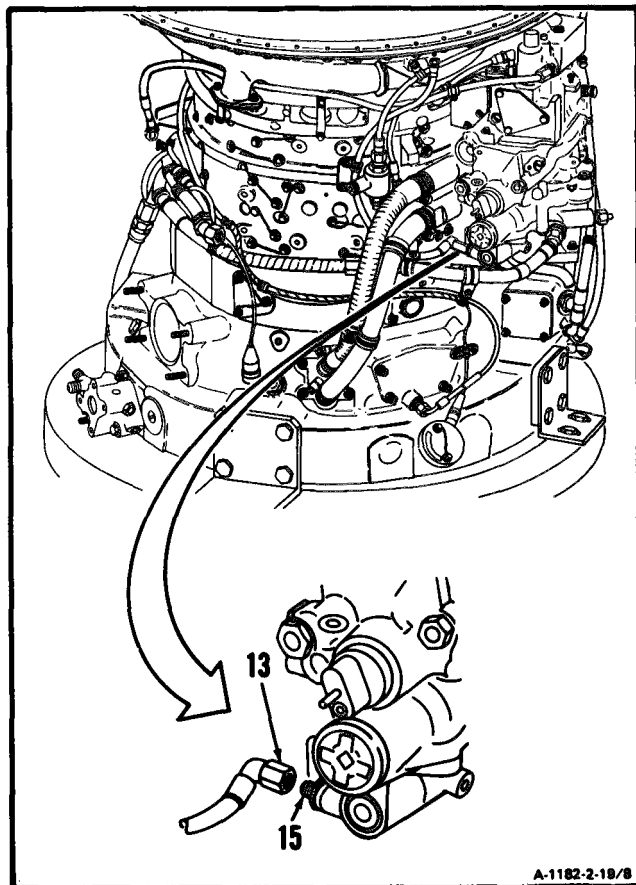

A-1182-2-19/8

GO TO NEXT PAGE

8. **Remove** lockwire, screw (16), and **clamp** (17).

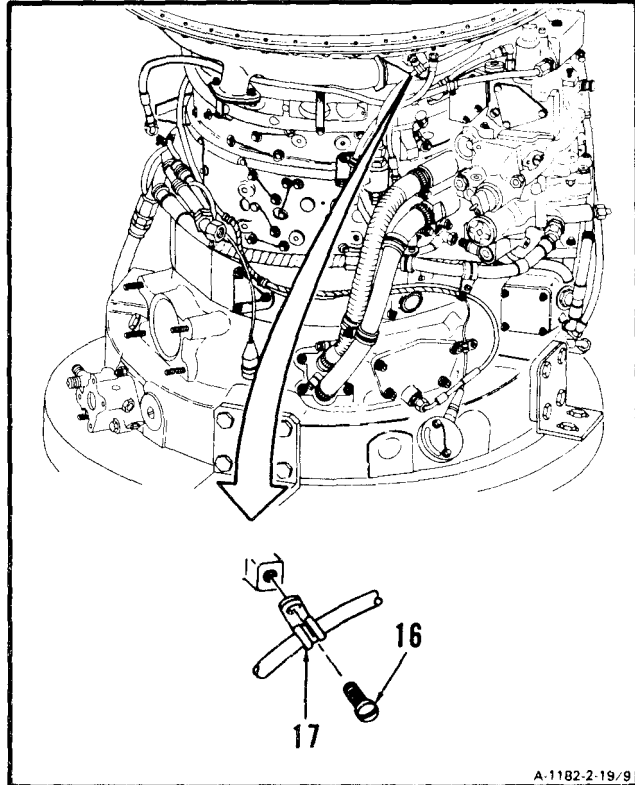

GO TO NEXT PAGE

9. Disconnect hose assembly (18).

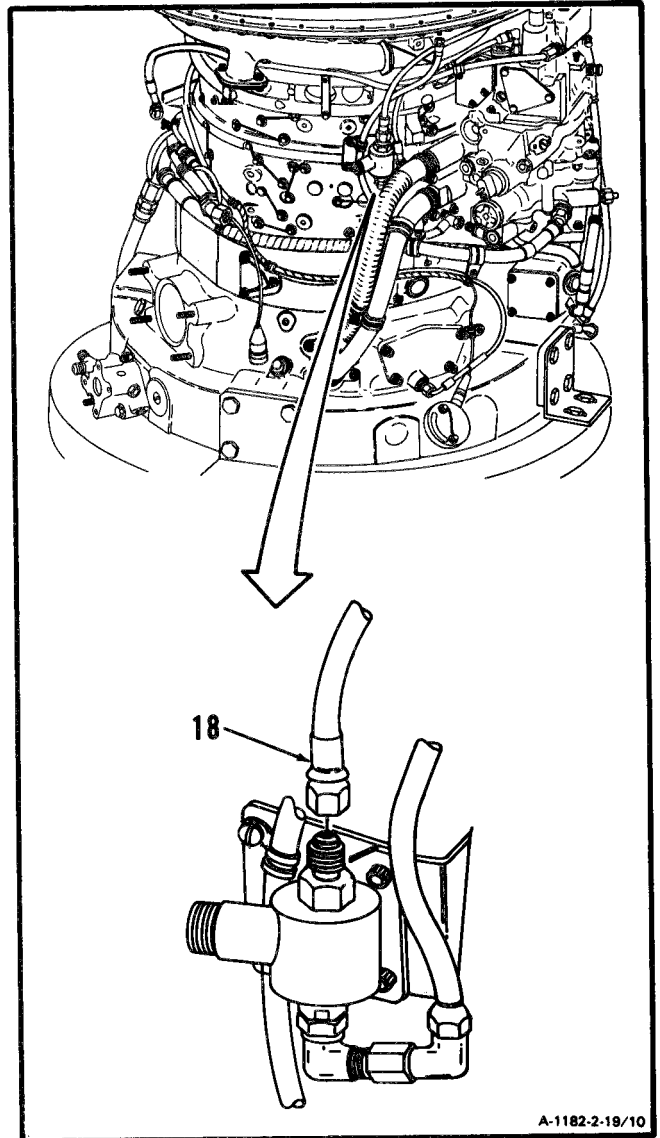

GO TO NEXT PAGE

10. Disconnect hose assembly (19).

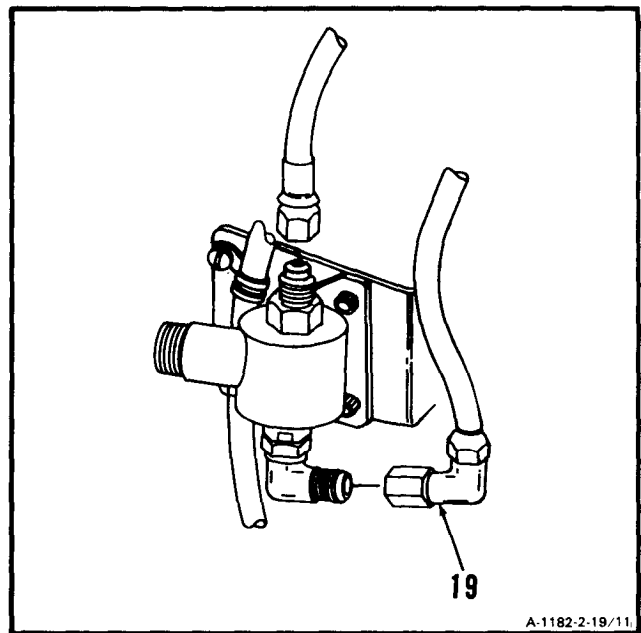

GO TO NEXT PAGE

2-19 REMOVE UPPER COMPRESSOR HOUSING (Continued)

2-19

11. Remove two nuts (20), washers (21), bolts (22), and spacers (23).
12. Remove solenoid valve (24), hose assembly (13), and bracket (25) as an assembly.

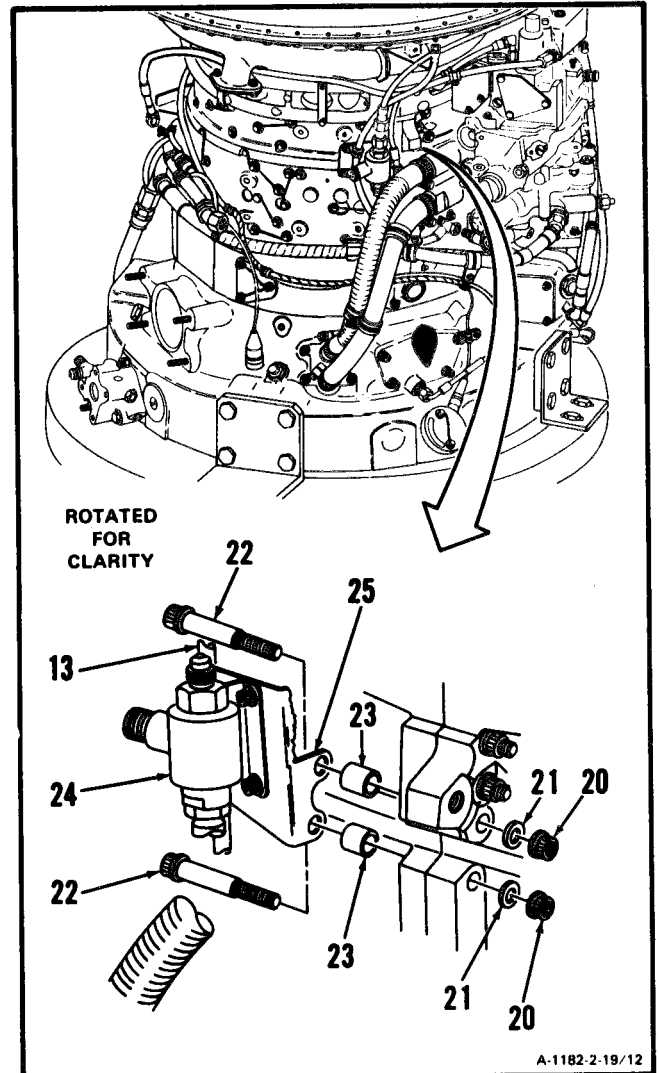
**GO TO NEXT PAGE**

13. Disconnect hose assembly (26).

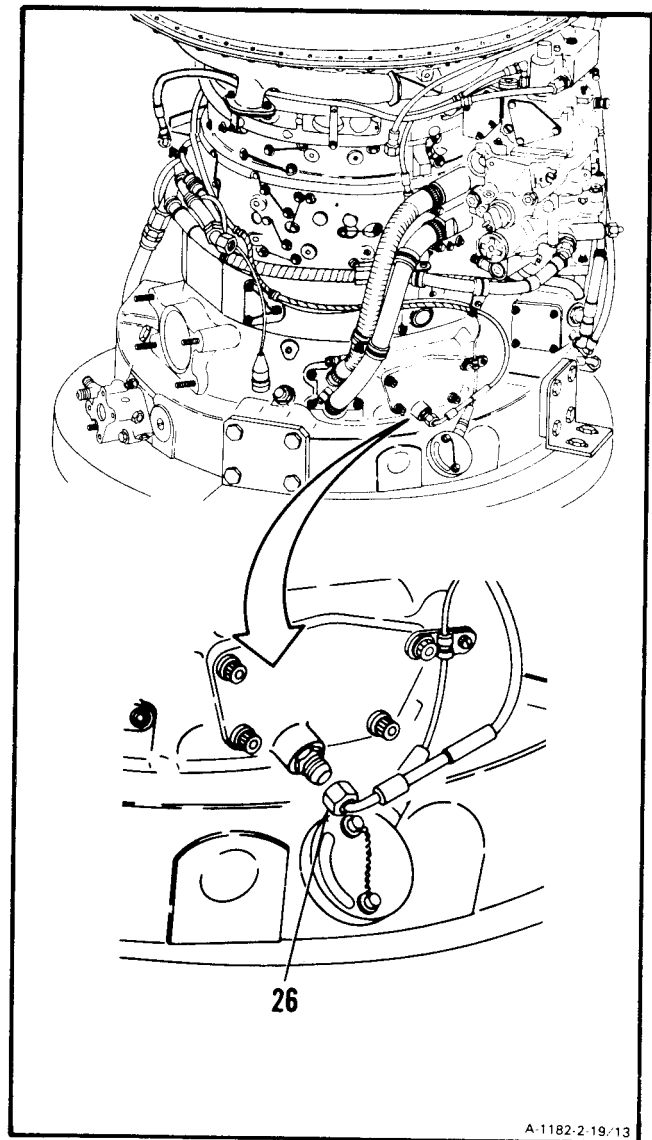

GO TO NEXT PAGE

2-19 REMOVE UPPER COMPRESSOR HOUSING (Continued)

2-19

14. Disconnect electrical connector (27).

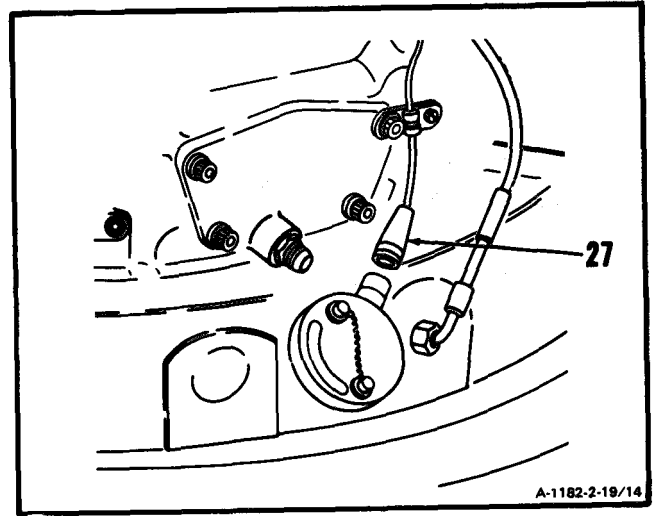

15. Remove nut (28), screw (29), and clamp (30).

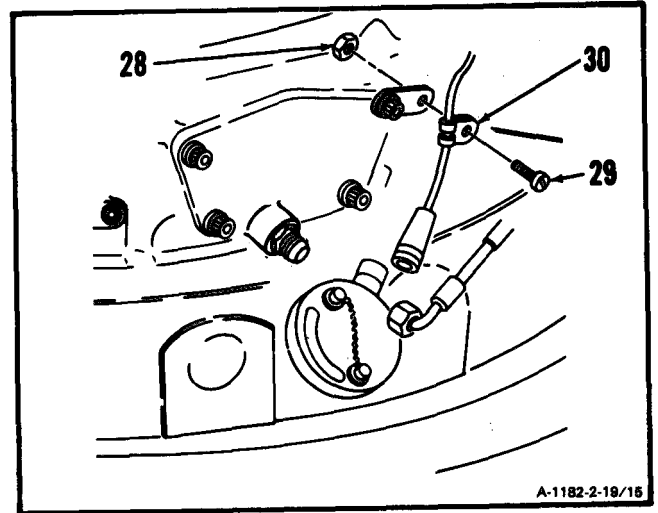

GO TO NEXT PAGE

16. Disconnect hose assembly (31).

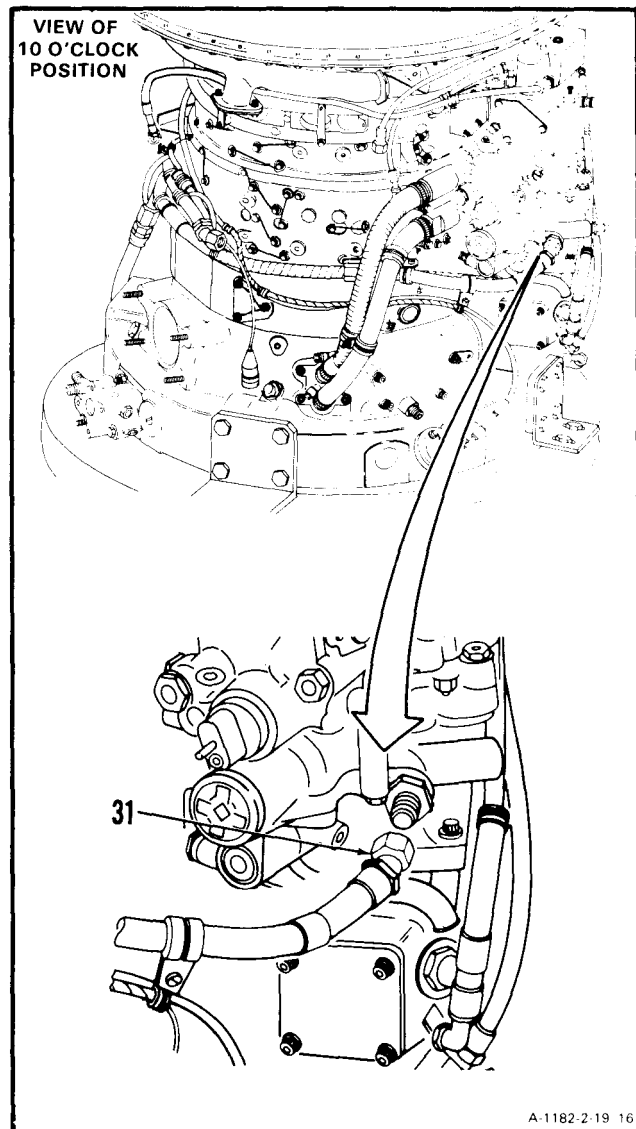

GO TO NEXT PAGE

2-19 REMOVE UPPER COMPRESSOR HOUSING (Continued)

2-19

17. Disconnect tube and hose assembly (32).

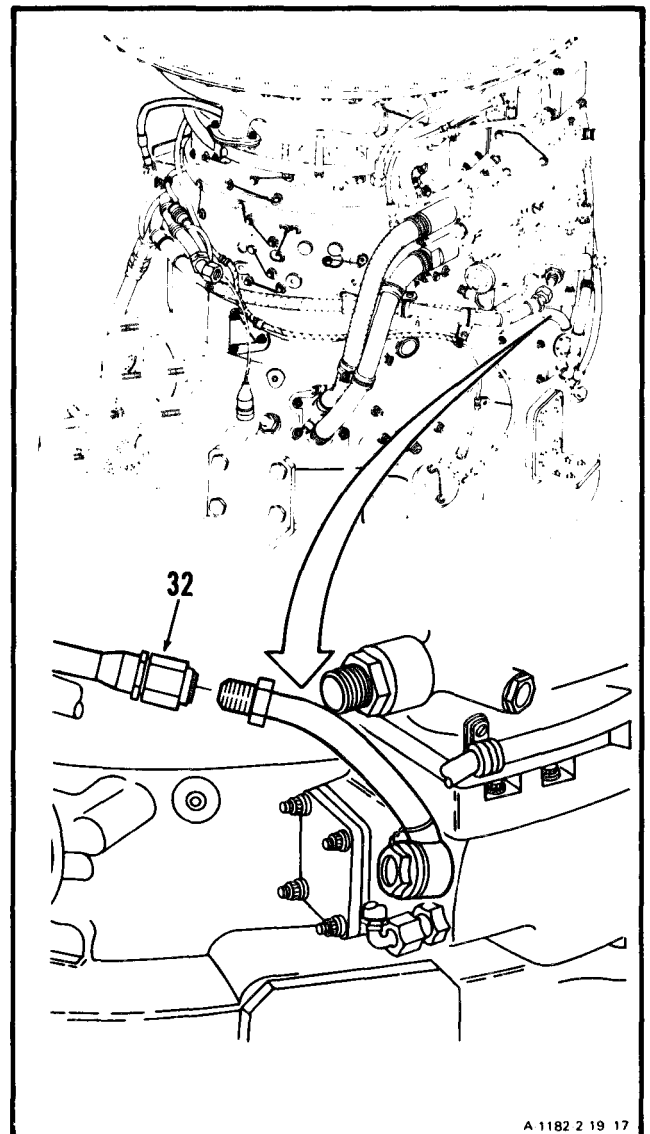

GO TO NEXT PAGE

2-19 REMOVE UPPER COMPRESSOR HOUSING (Continued)

2-19

18. Move hose assemblies (26, 31, and 32) and electrical cable leads (33 and 34) away from compressor housing (35).

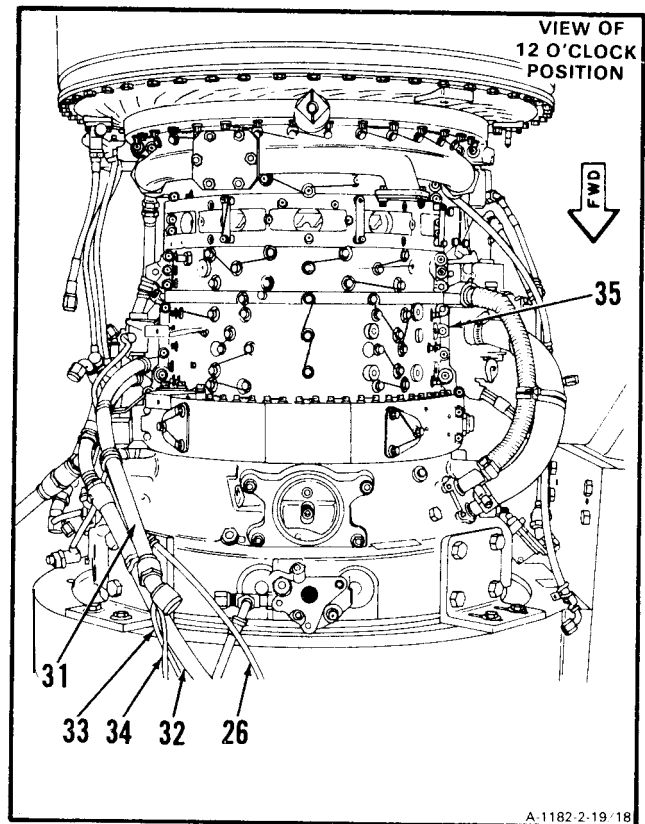

A-1182-2-19-18

GO TO NEXT PAGE

2-19 REMOVE UPPER COMPRESSOR HOUSING (Continued)

2-19

19. **Remove** lockwire, two bolts (36), washers (37), **bracket (38)**, and spacers (39).

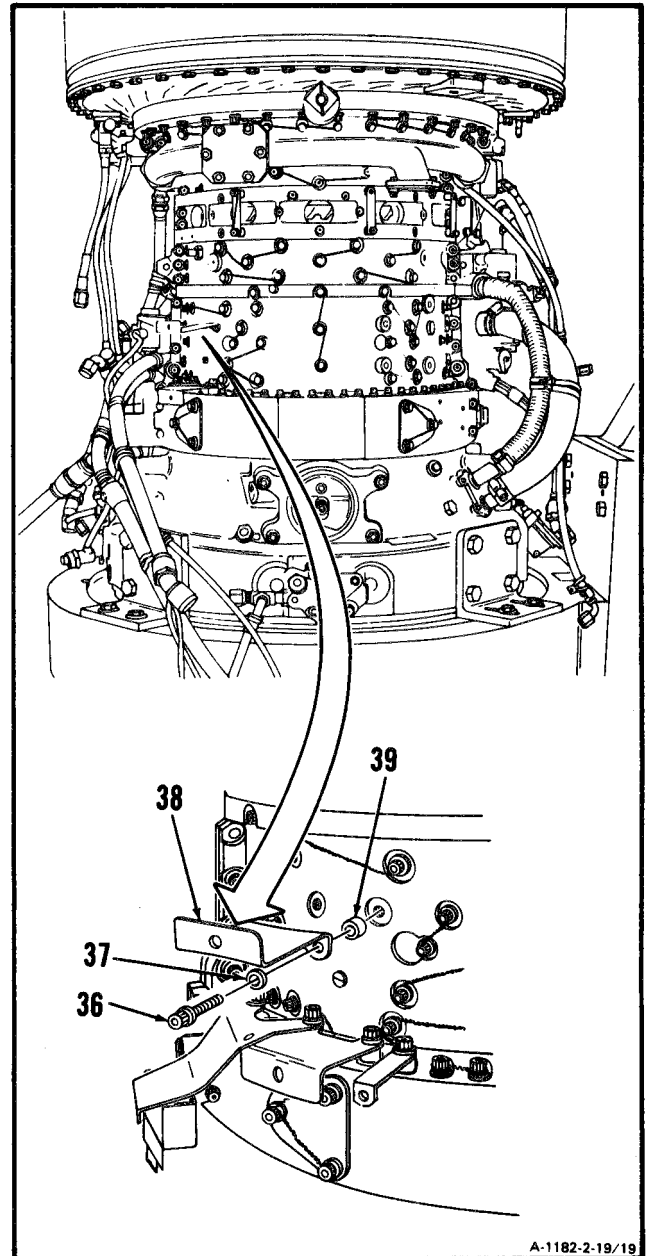

GO TO NEXT PAGE

2-19 REMOVE UPPER COMPRESSOR HOUSING (Continued)

20. **Remove** lockwire, two bolts (40), washers (41), **bracket (42)**, and spacer (43).

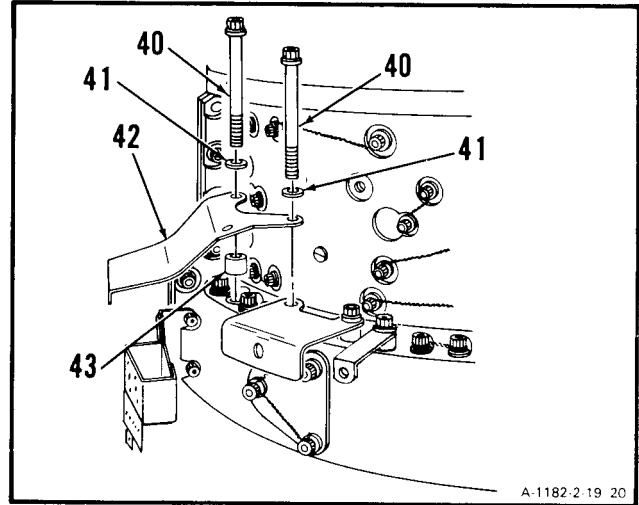

21. **Remove** lockwire, bolt (44), washer (45), **bracket (46)** and spacers (47 and 48).

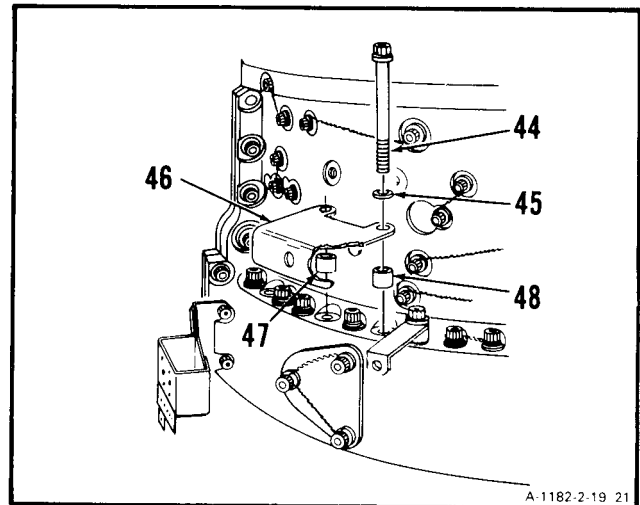

GO TO NEXT PAGE

2-19 REMOVE UPPER COMPRESSOR HOUSING (Continued)

2-19

22. Remove lockwire, two bolts (49), brackets (50 and 51), and spacers (52).

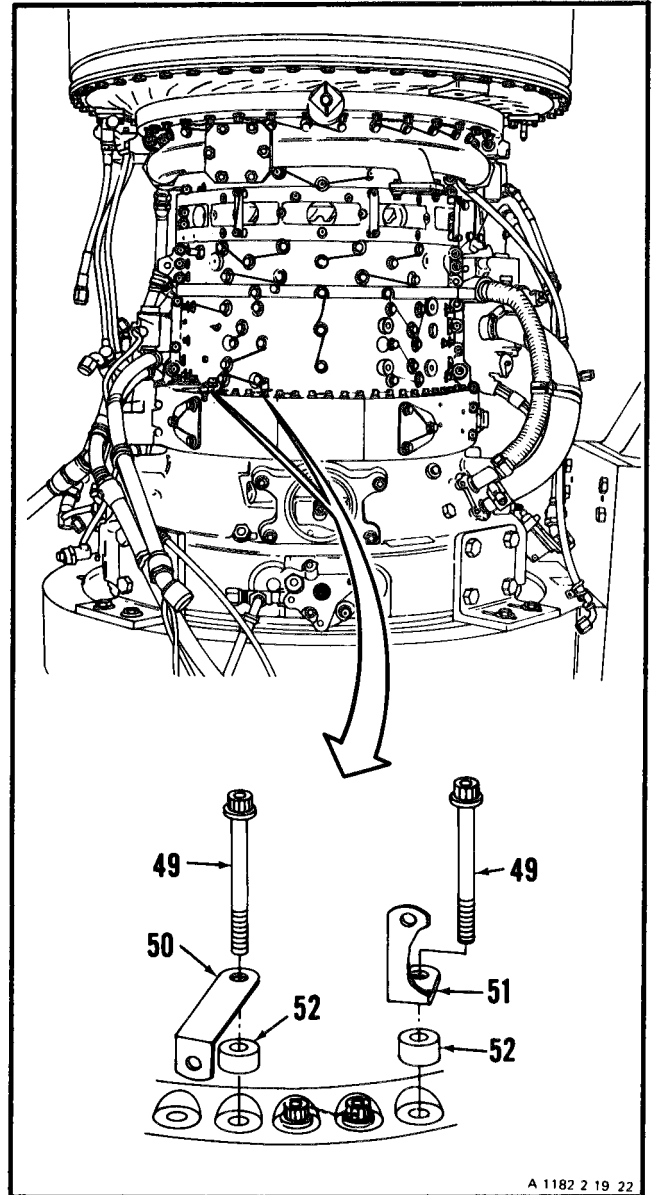

GO TO NEXT PAGE

23. **Remove** lockwire, 23 **bolts** (53), and washers (54).

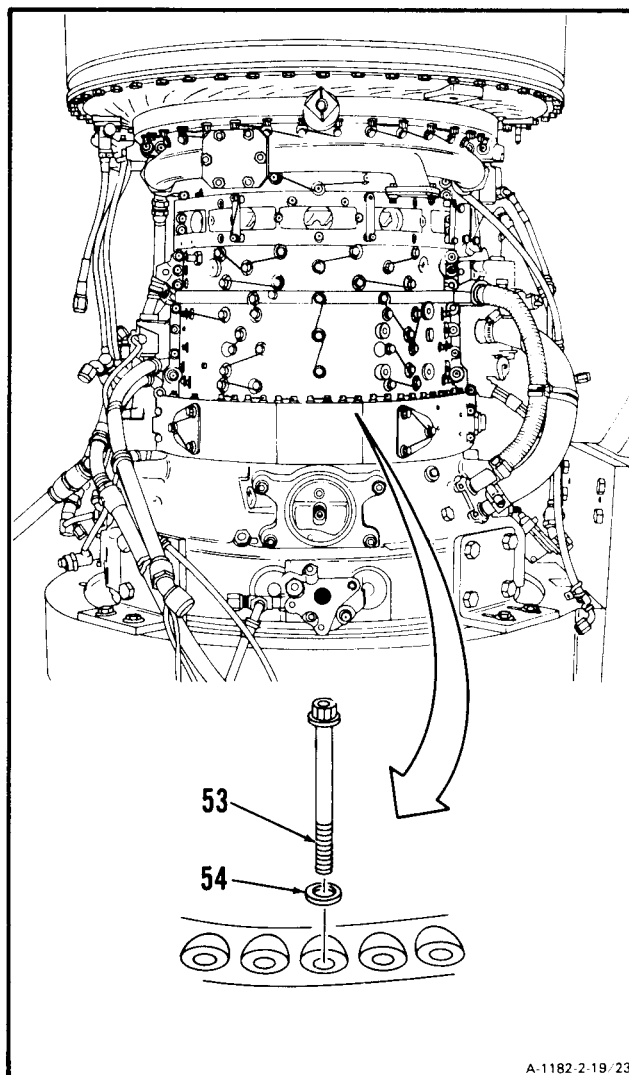

A-1182 2-19 / 23

GO TO NEXT PAGE

24. **Remove** lockwire, **16 bolts (55)**, and washers **(56)**.

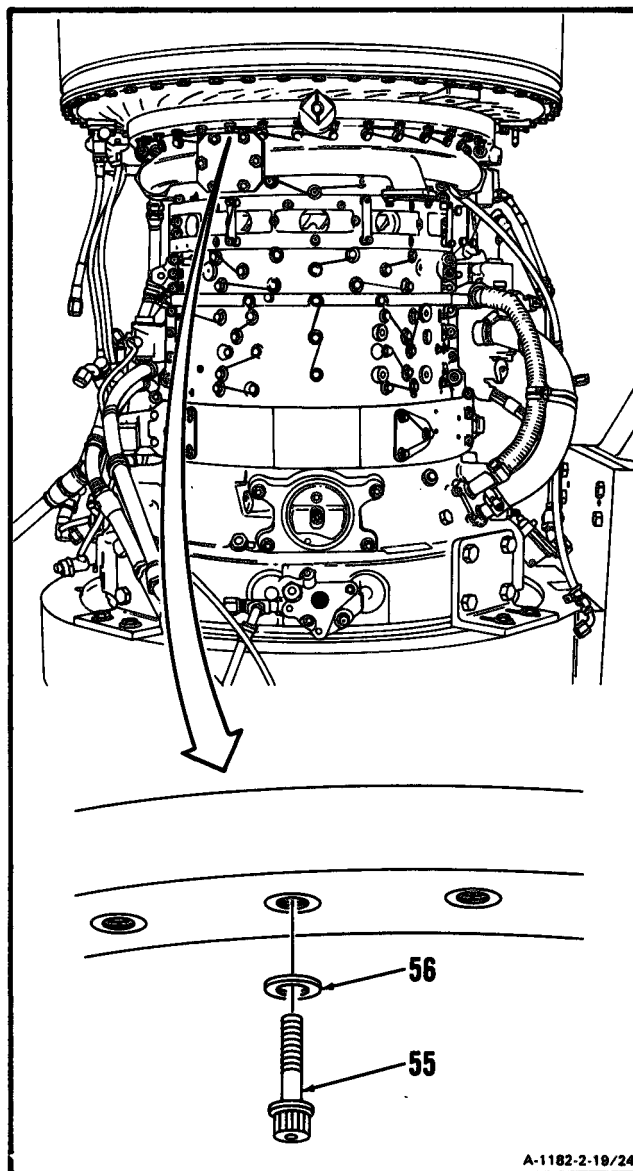

A-1182-2-18/24

GO TO NEXT PAGE

25. Remove lockwire. **Disconnect nut (57)** from connector (58). Use padded conduit pliers.

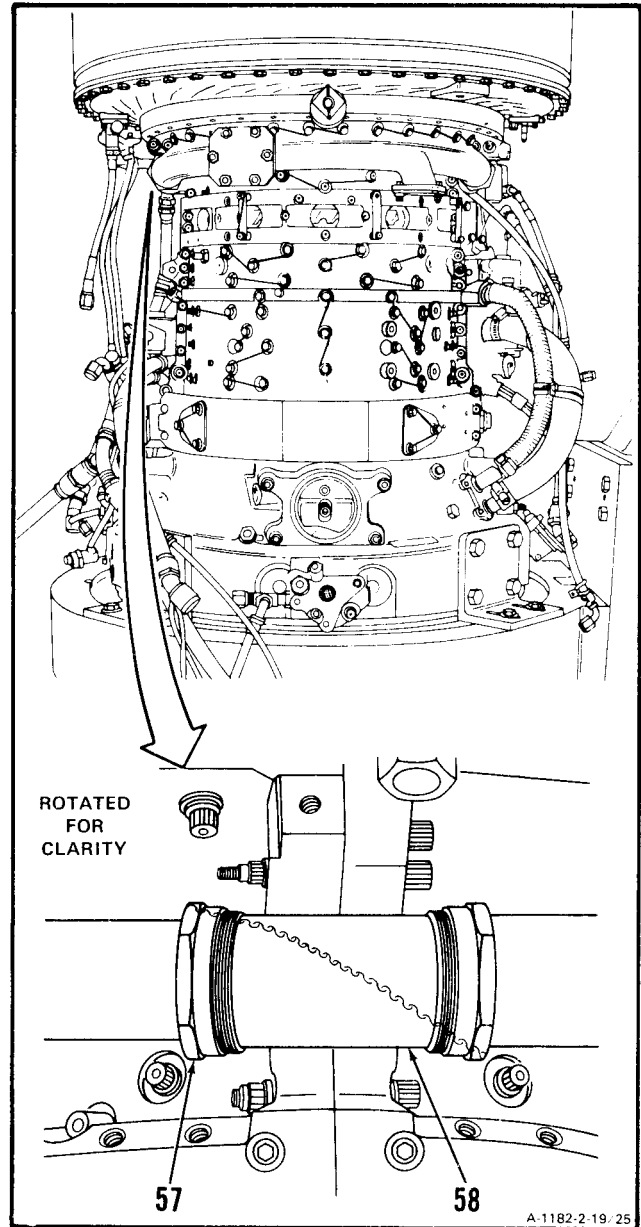

GO TO NEXT PAGE

2-19 REMOVE UPPER COMPRESSOR HOUSING (Continued)

2-19

26. Remove lockwire. **Disconnect nut (59)** from connector (60). Use padded conduit pliers.

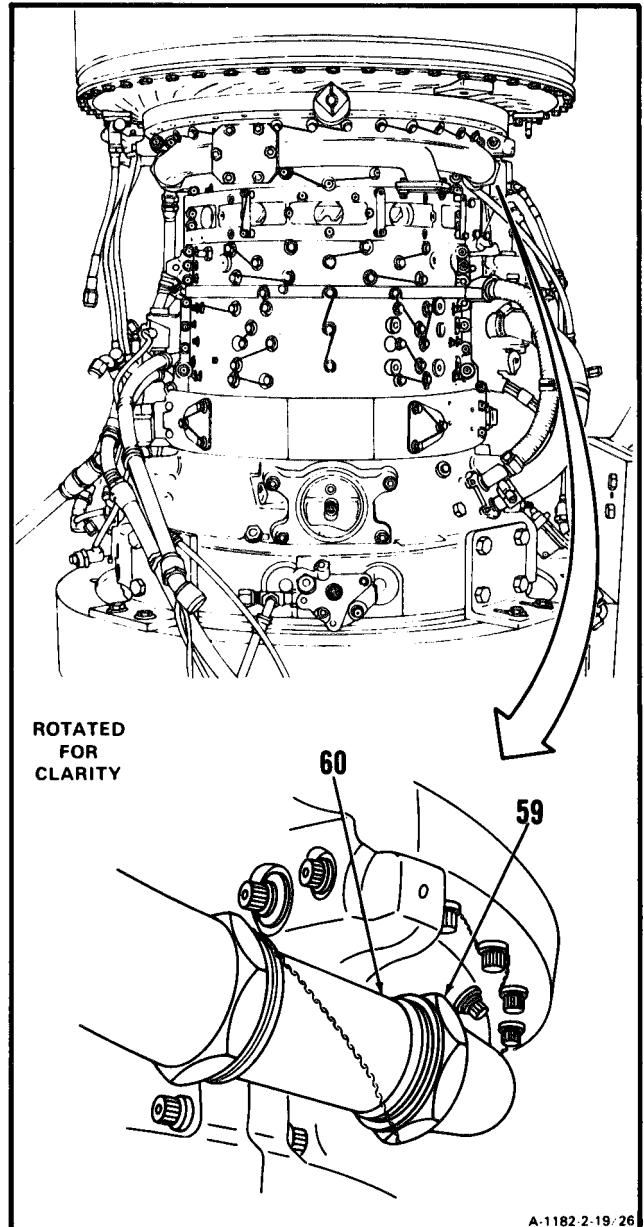

GO TO NEXT PAGE

- 27. Remove lockwire and bolt (61).
- 28. **Remove** two nuts (62), washers (63), bolts (64), bracket (65), and spacers (66).

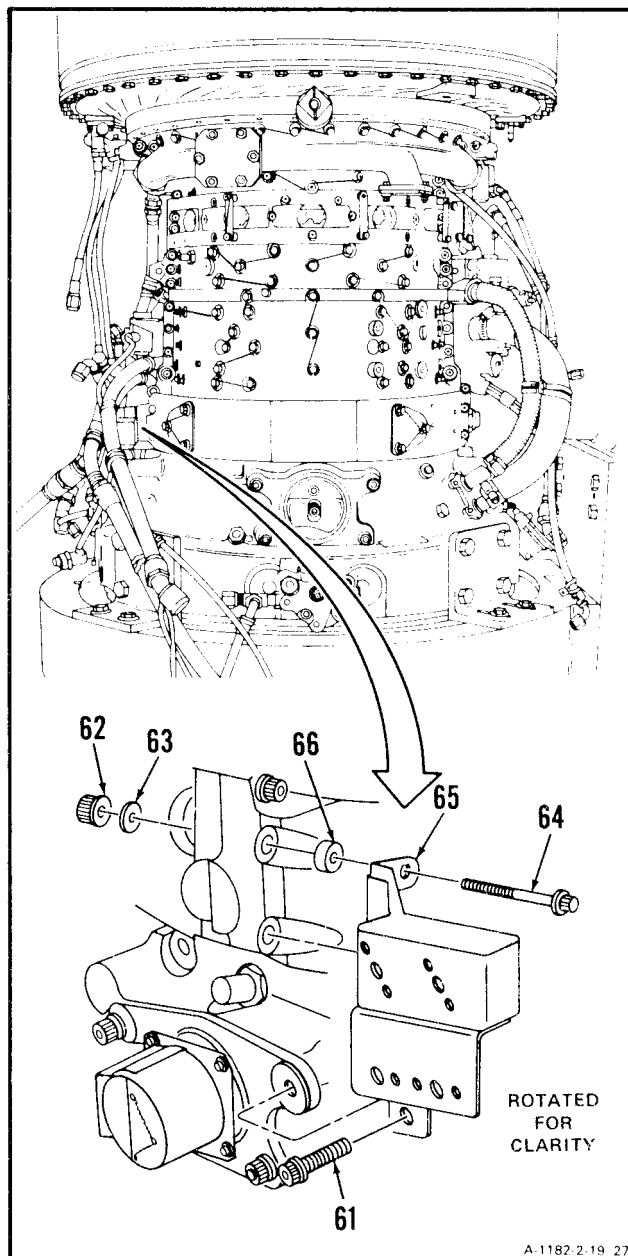

GO TO NEXT PAGE

NOTE

Procedure for removing nuts, bolts and washers from four dowel pins is the same.

- 29 **Remove** four nuts (67), washers (68), and bolts (69) from dowel pins (70).

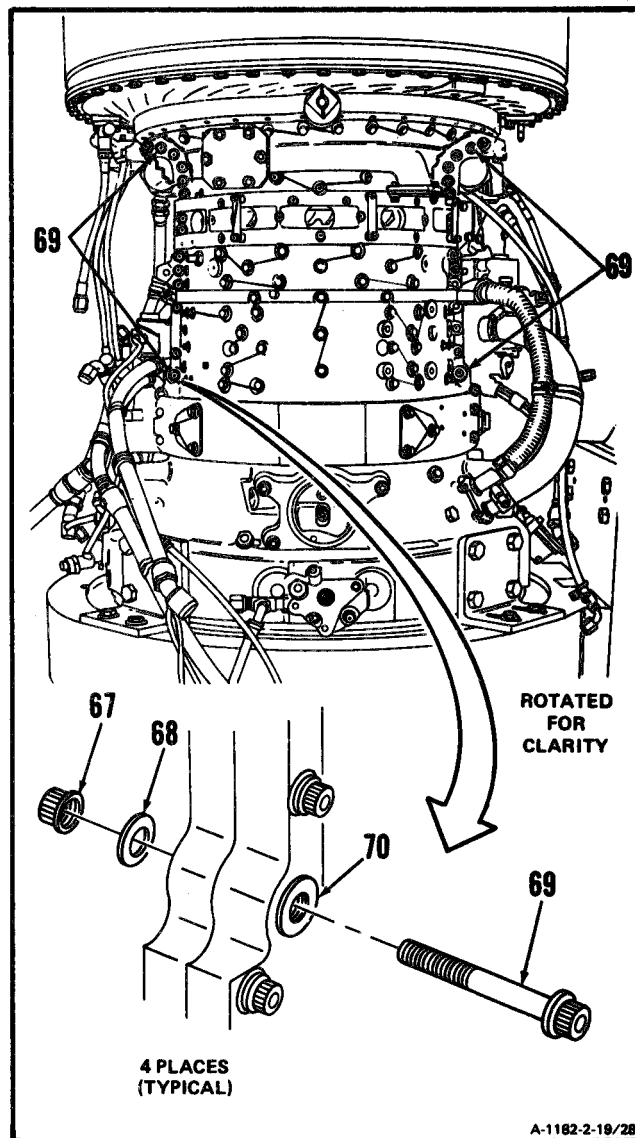

GO TO NEXT PAGE

NOTE

Procedure for removing four dowel pins is the same. Procedure for only one is shown.

30. Thread mechanical puller (T6) (71) into dowel pin (70).

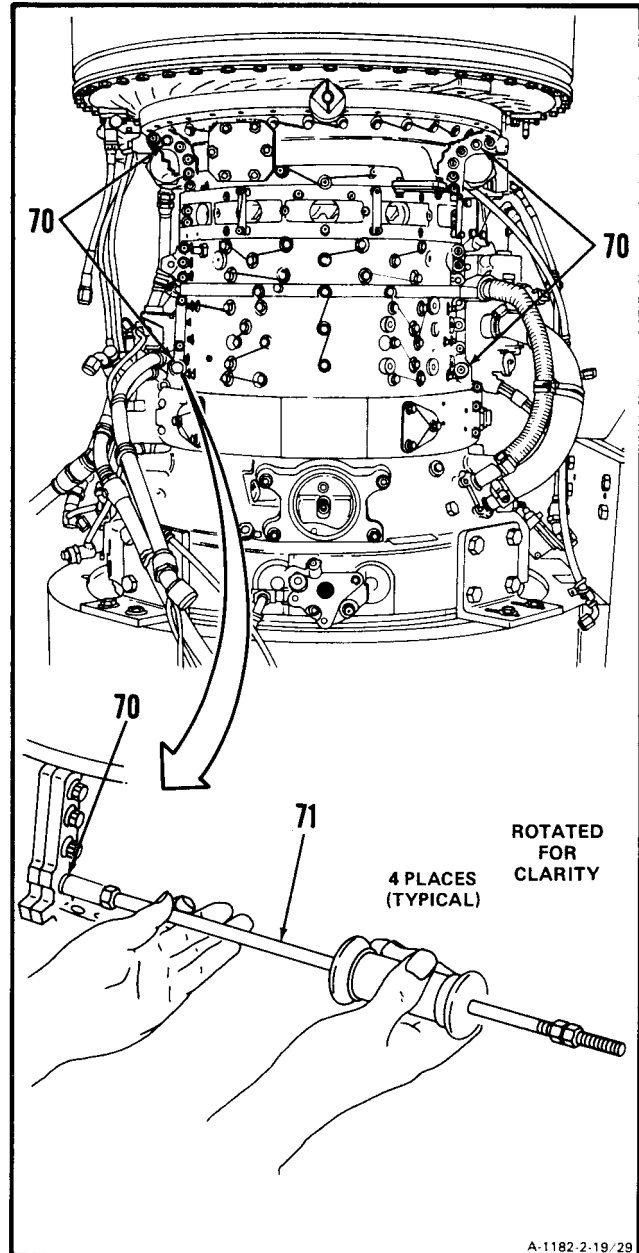

A-1182-2-19/29

GO TO NEXT PAGE

31. Slide mechanical puller handle (72) up against nuts (73) and **remove dowel pin (70)**.
32. Remove dowel pin (70) from mechanical puller (T6) (71).

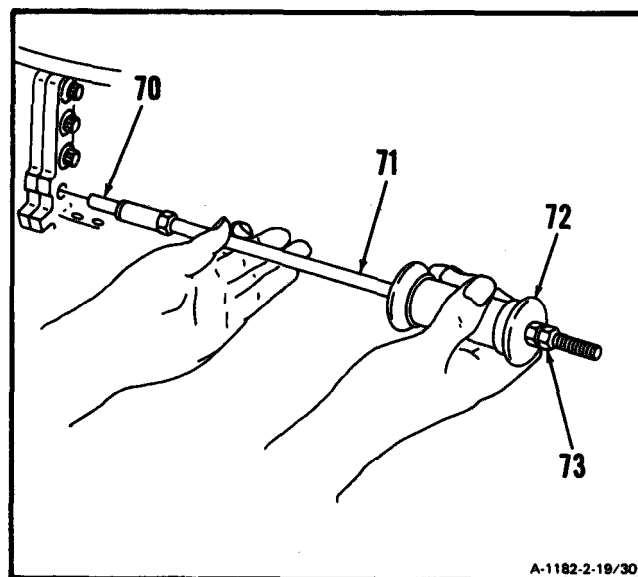

GO TO NEXT PAGE

33. **Remove** two nuts (74), four washers (75), and two bolts (76) .

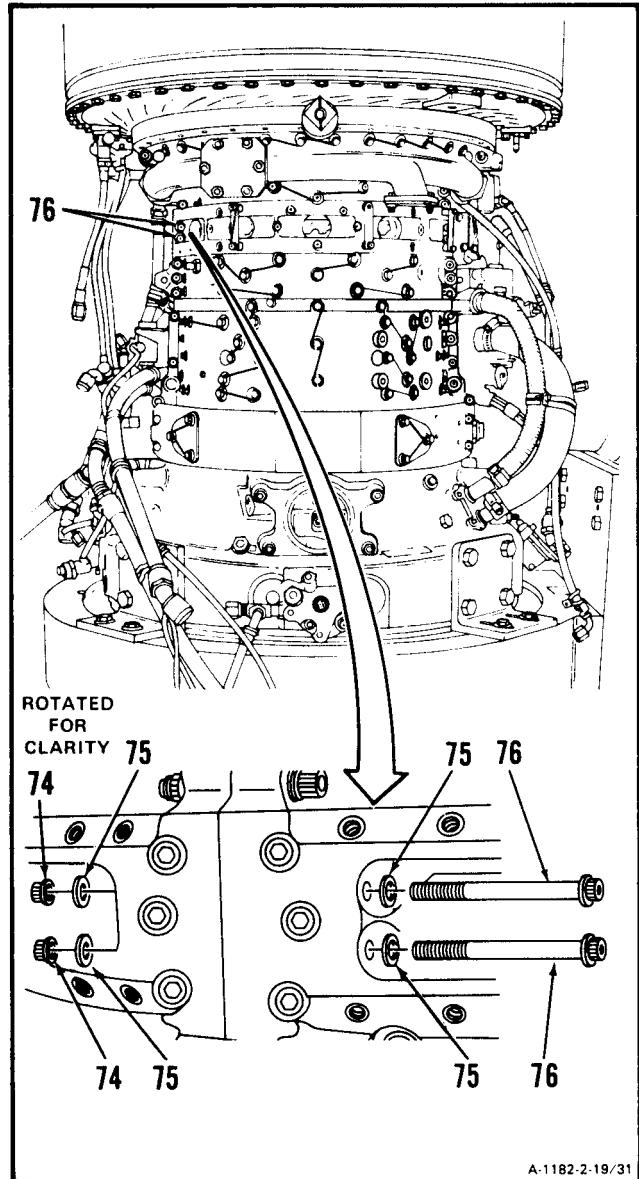

GO TO NEXT PAGE

34. Remove lockwire, bolt (77), and bleed bend retainer (78).

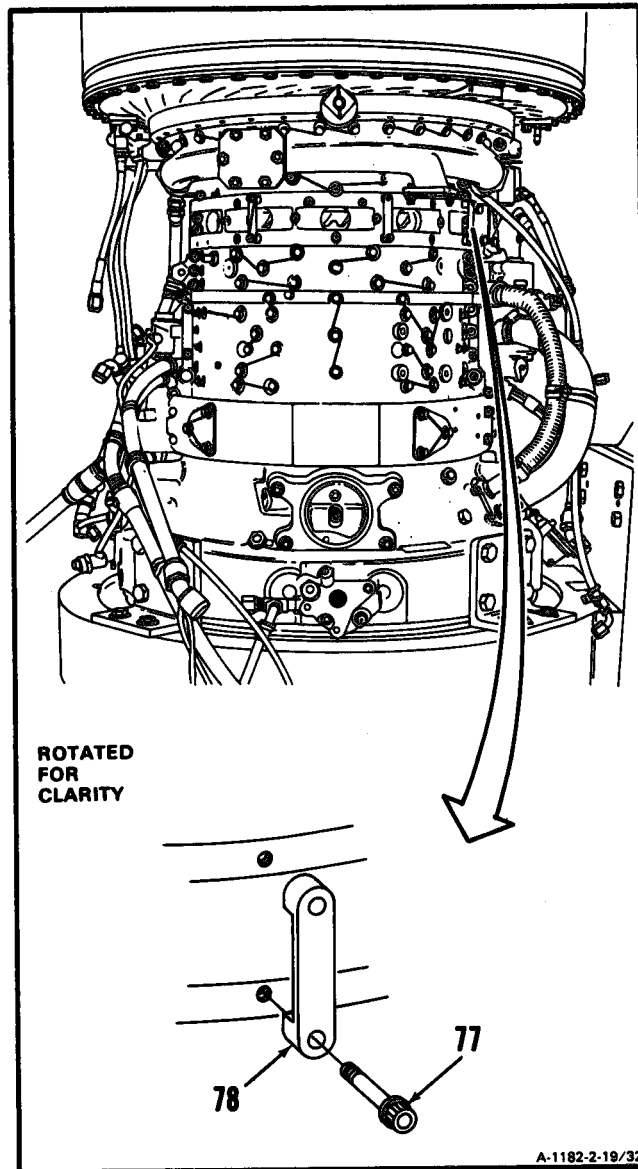

A-1182-2-19/32

GO TO NEXT PAGE

35. **Remove** two nuts (79), four washers (80), and two bolts (81).

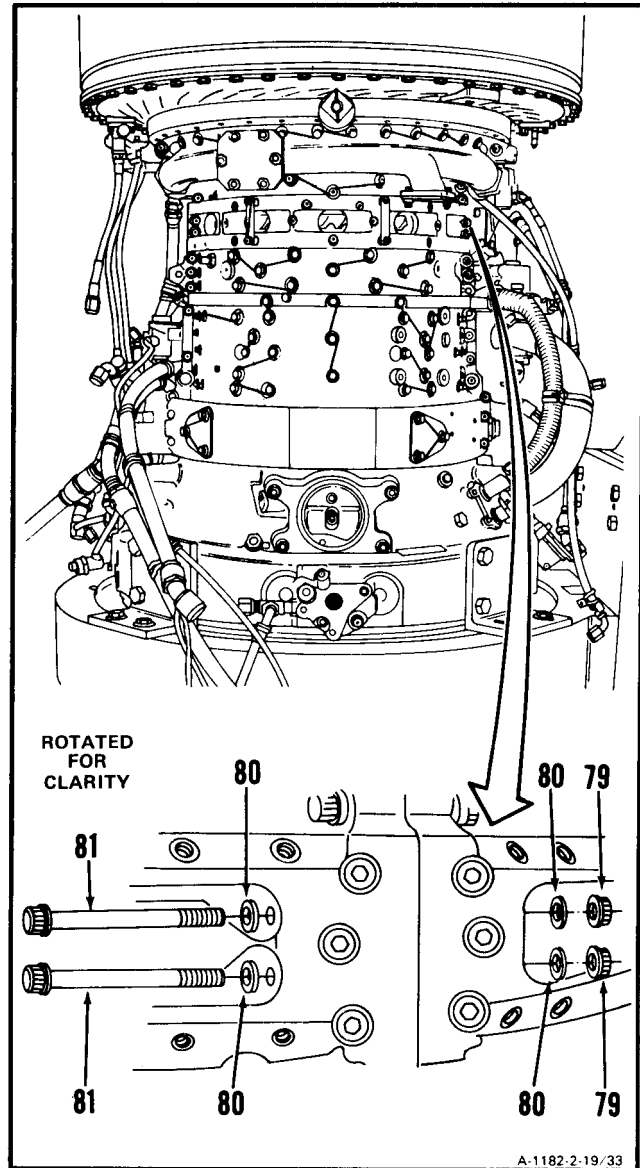

GO TO NEXT PAGE

2-19 REMOVE UPPER COMPRESSOR HOUSING (Continued)

2-19

36. **Remove** three nuts (82), six washers (83), and three bolts (84).

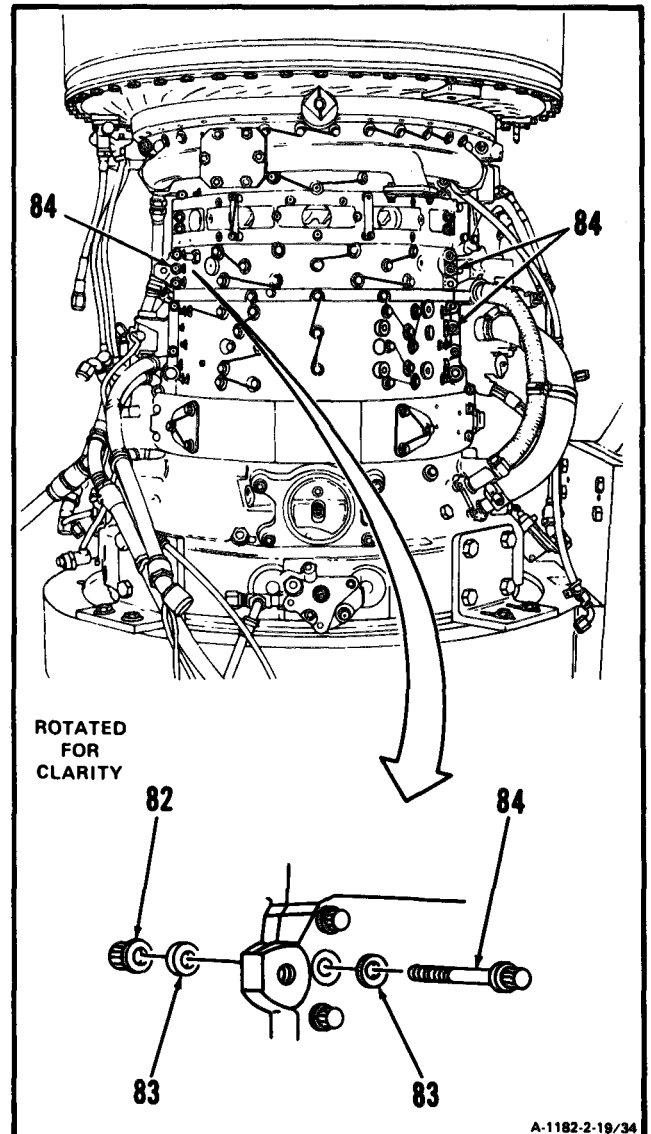

GO TO NEXT PAGE

37. **Remove** 21 nuts (85), 42 washers (86), and 21 bolts (87).

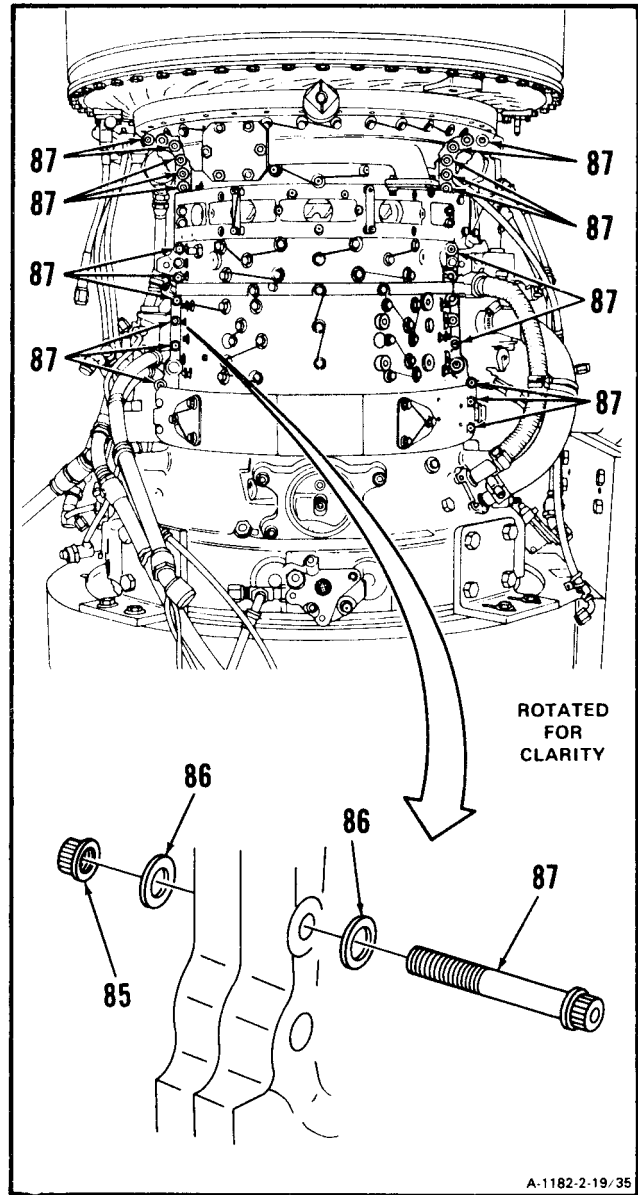

GO TO NEXT PAGE

2-19 REMOVE UPPER COMPRESSOR HOUSING (Continued)

2-19

38. Have helper lift upon combustion section and power turbine (88) and **remove upper compressor housing (89)**.

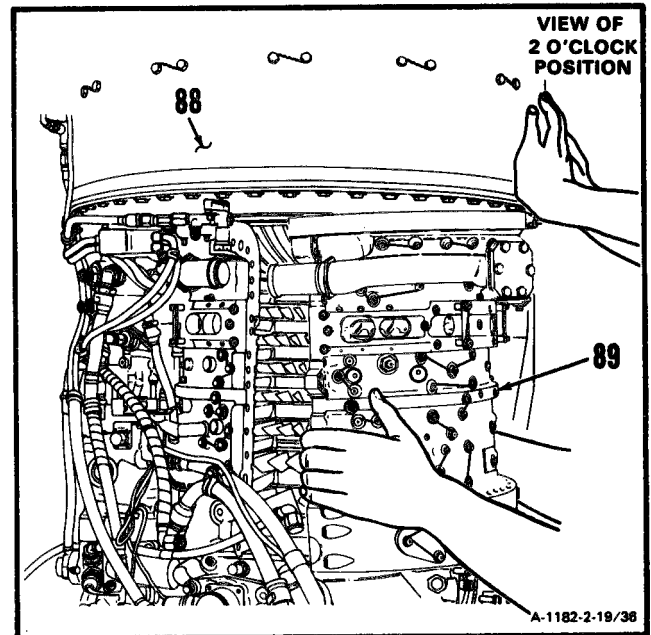

FOLLOW-ON MAINTENANCE:

None

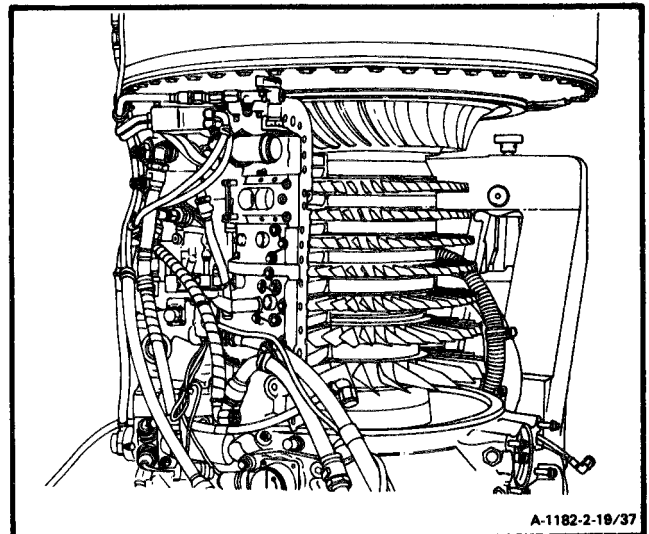

END OF TASK

INITIAL SETUP

Applicable Configurations:

All

Tools:

Powerplant Mechanic's Tool Kit,
NSN 5180-00-323-4944
Mechanical Puller (T6)
Padded Conduit Pliers

Materials:

None

Personnel Required:

68B10 Aircraft Powerplant Repairer (2)

Equipment Condition:

Engine Oil System Drained (Task 1-75)
Ignition Exciter Removed (Task 7-11)
Oil Cooler Assembly Removed (Task 8-5)
In-Line Fuel Filter Assembly Removed
(Task 6-36)
Dual Chip Detector Removed (Task 8-28)
Fuel Boost Pump Assembly Removed (Task 6-9)
Hose Assembly (Inlet Housing to Mail Oil Pump)
Removed (Task 8-50)
Main Oil Pump and Scavenge Oil Screen Re-
moved (Task 8-1)
Fuel Control Removed (Task 6-1)
Accessory Gearbox Assembly Removed
(Task 5-1)
Main Fuel Filter and Bracket Removed
(Task 6-29)
Interstage Air-Bleed Actuator Removed
(Task 2-1)
Compressor Bleed Band Removed (Task 2-9)

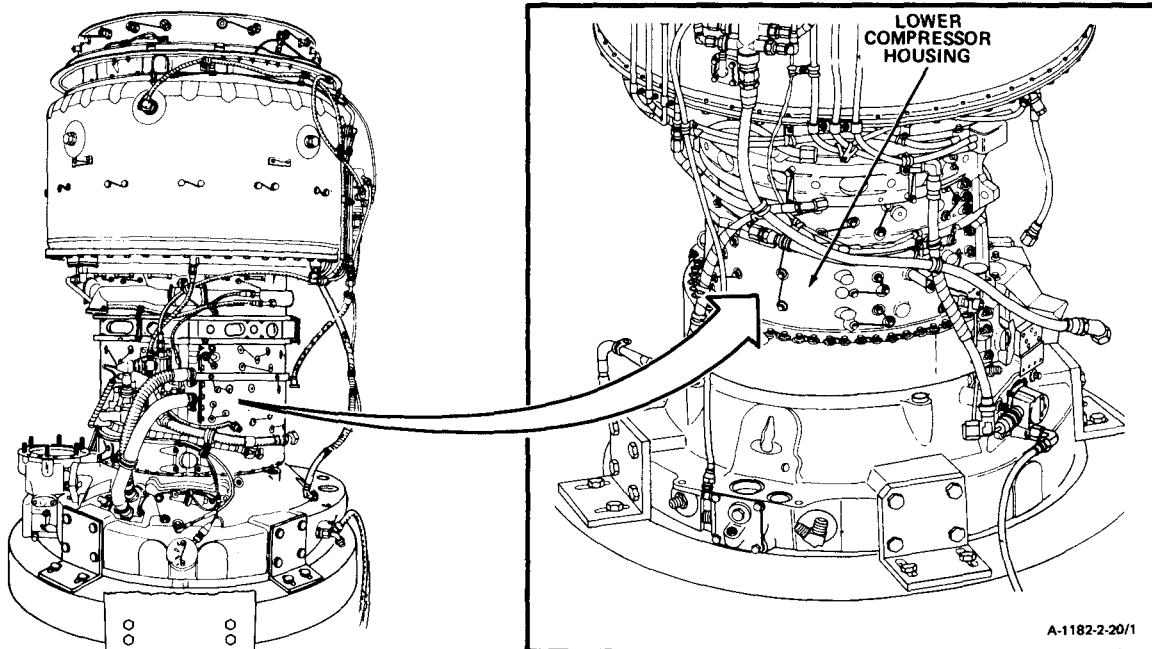

GO TO NEXT PAGE

2-20 REMOVE LOWER COMPRESSOR HOUSING (Continued)

2-20

CAUTION

When removing compressor housing, only upper or lower compressor housing half shall be removed-at one time. At no time shall personnel attempt to remove both upper and lower compressor housing halves at the same time. Failure to comply will cause engine damage.

1. Disconnect hose assembly (1).

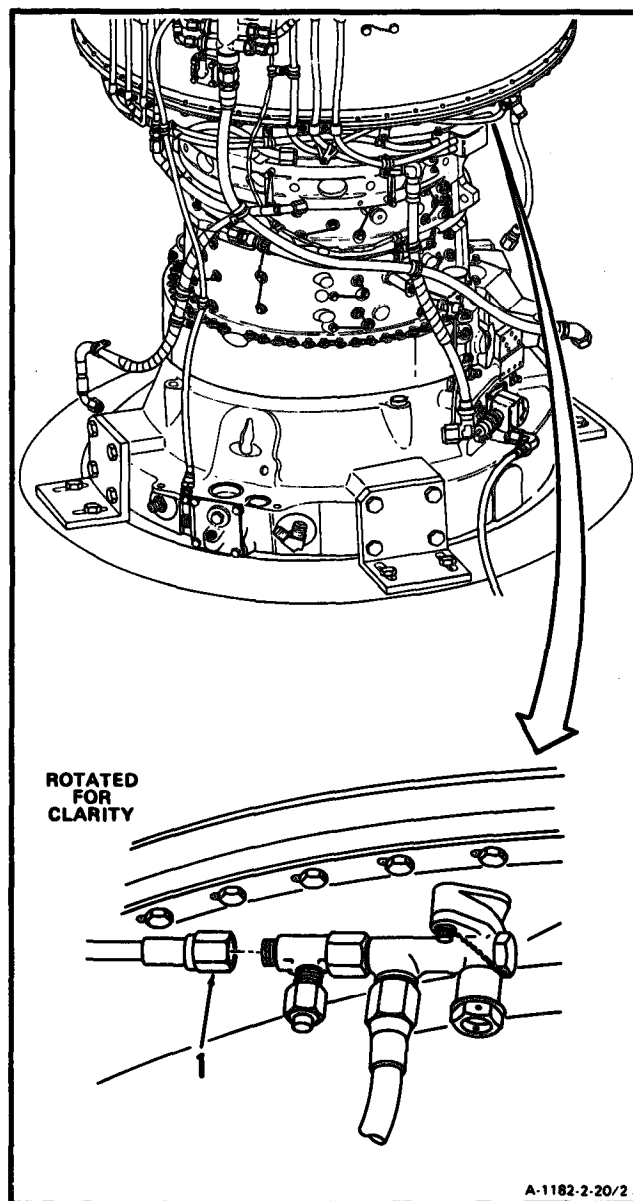

A-1182-2-20/2

GO TO NEXT PAGE

2. **Remove** lockwire, two bolts (2), **connector (3),** and packing (4).

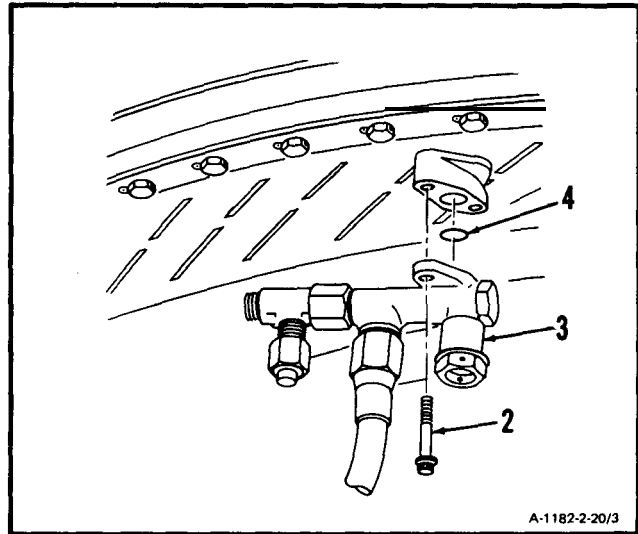

3. Remove two nuts (5) and bolts (6) and **remove ignition coil and cable (7)** from bracket (8).

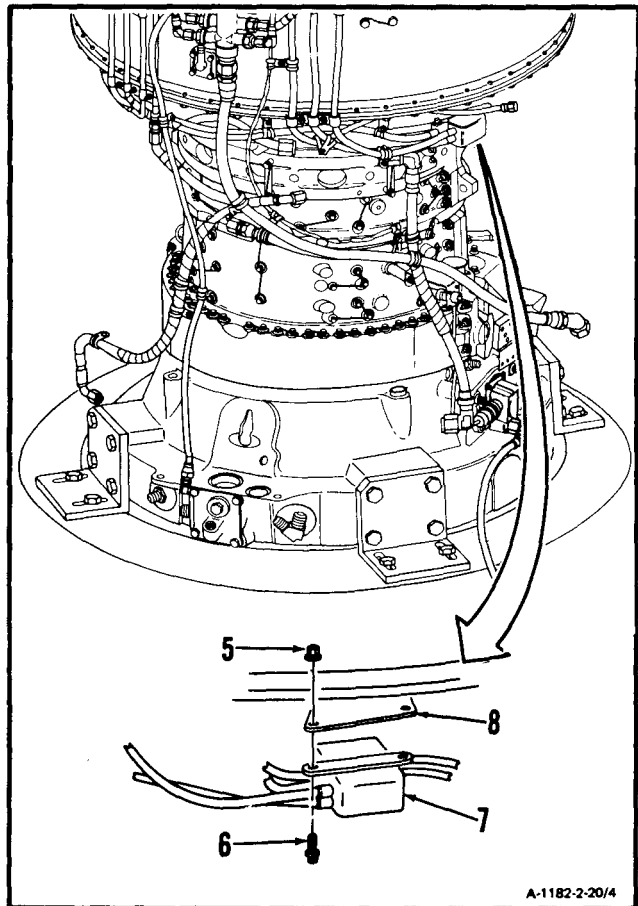

GO TO NEXT PAGE

2-20 REMOVE LOWER COMPRESSOR HOUSING (Continued)

2-20

4. Disconnect electrical cable (9).

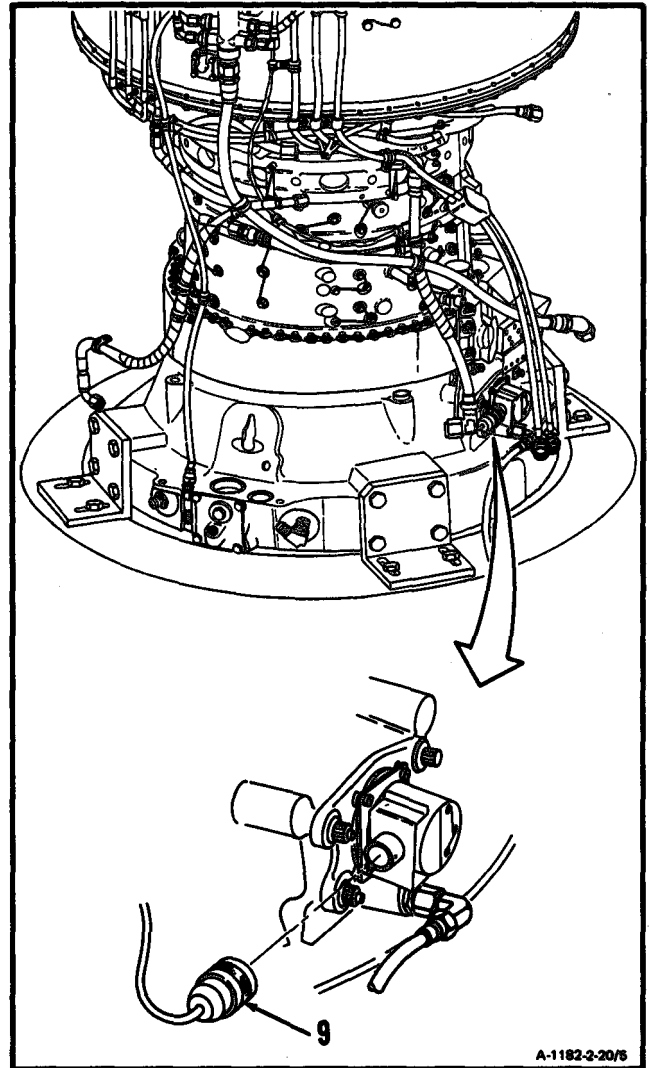

GO TO NEXT PAGE

5. **Remove** lockwire, two bolts (10), washers(11), **bracket (12)** and two spacers (13).

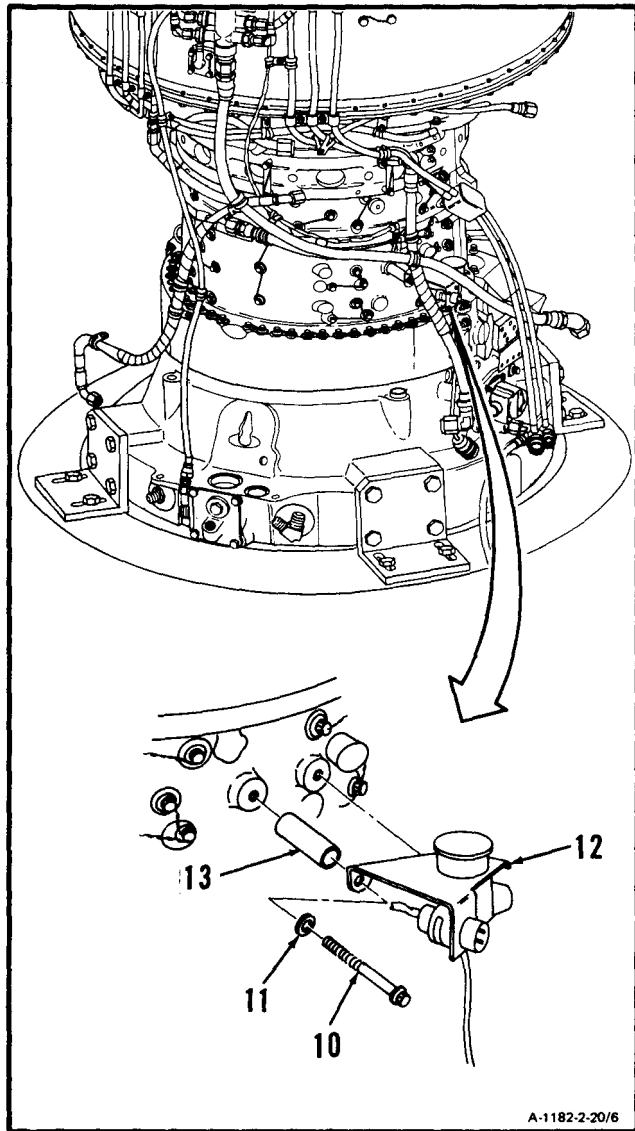

GO TO NEXT PAGE

2-20 REMOVE LOWER COMPRESSOR HOUSING (Continued)

2-20

6. Remove two screws (14) and thermocouple leads (15).

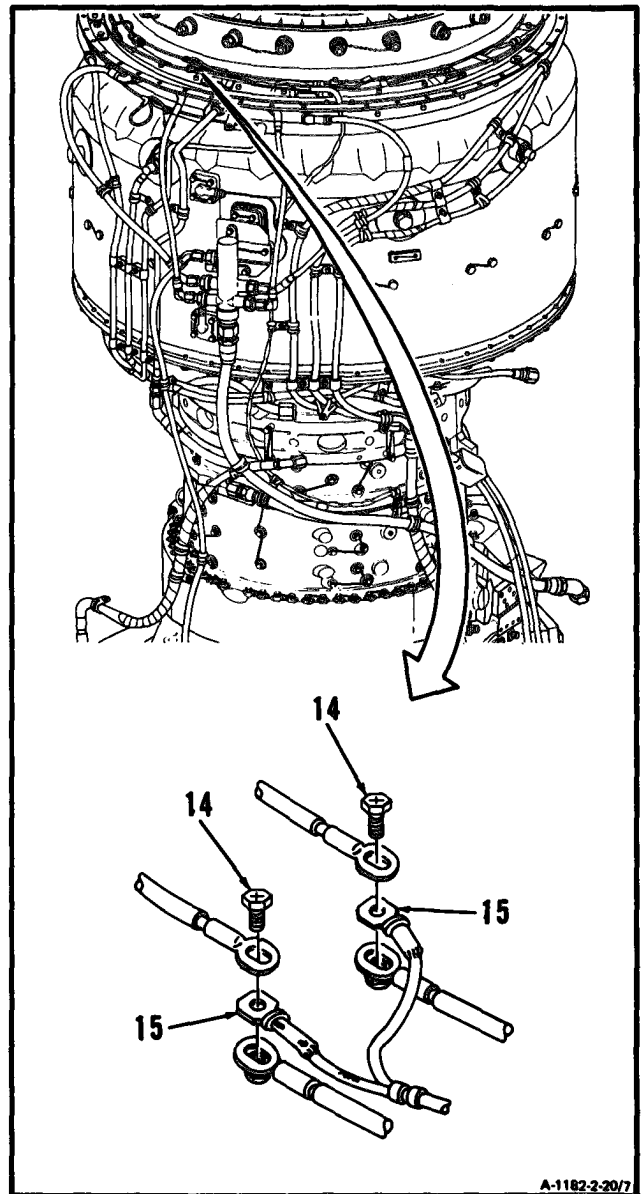

GO TO NEXT PAGE

7. Remove two bolts (16) and nuts (17) and pull thermocouple leads (18) through fireshield (19).

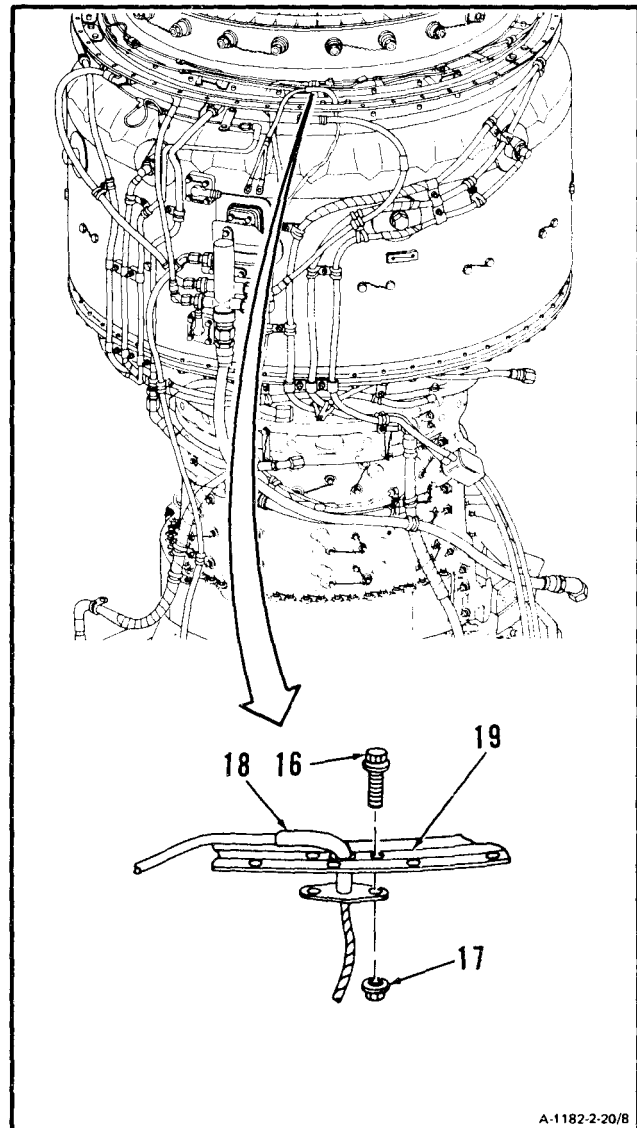

A-1182-2-20/8

GO TO NEXT PAGE

2-20 REMOVE LOWER COMPRESSOR HOUSING (Continued)

2-20

8. Remove lockwire, screw (20), and clamp (21).

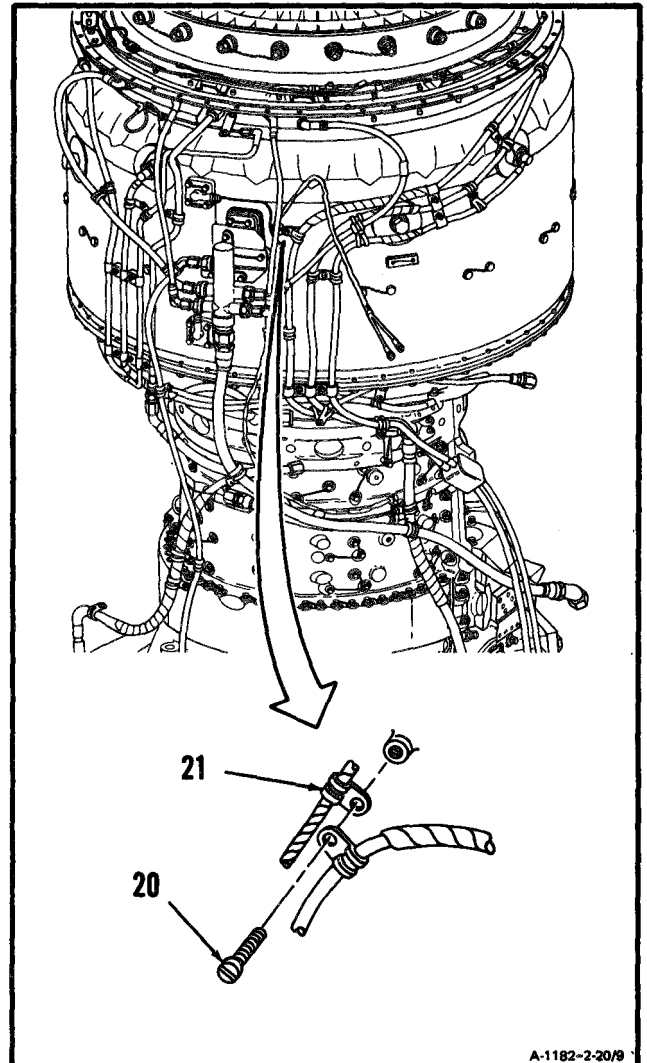

GO TO NEXT PAGE

9. Remove screw (22), nut (23), and clamp (24).

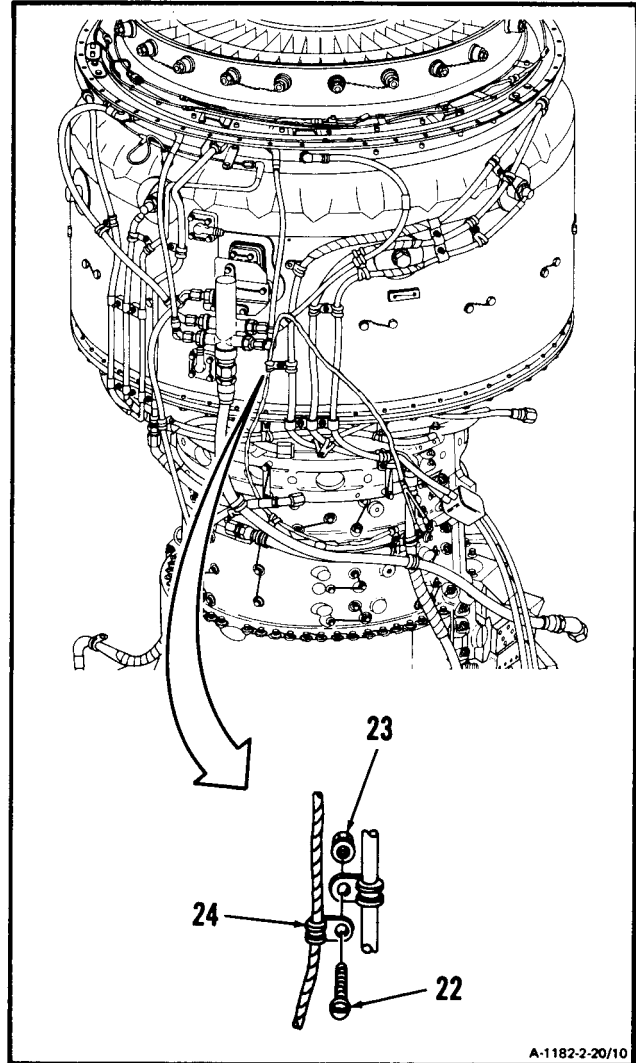

A-1182-2-20/10

GO TO NEXT PAGE

2-20 REMOVE LOWER COMPRESSOR HOUSING (Continued)

2-20

10. Bend tabs of key washer (25) and **remove** bolt (26), key washer (25), and **bracket (27)**.

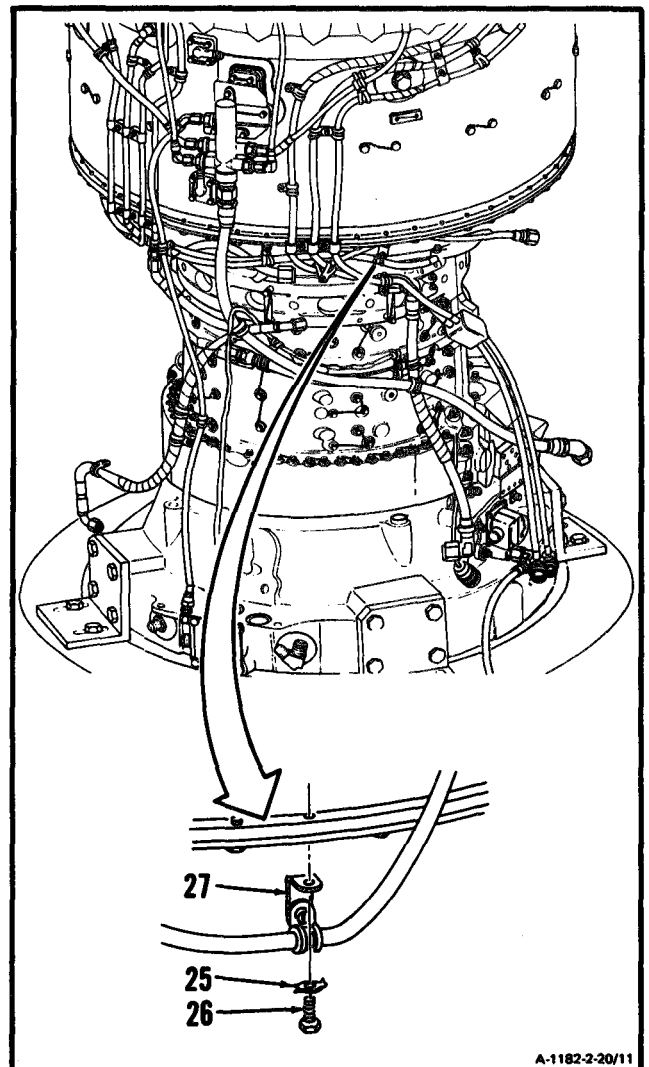

GO TO NEXT PAGE

11. Bend tabs of two key washers (28) and **remove** two bolts (29), key washers (28), and **bracket (30)**.

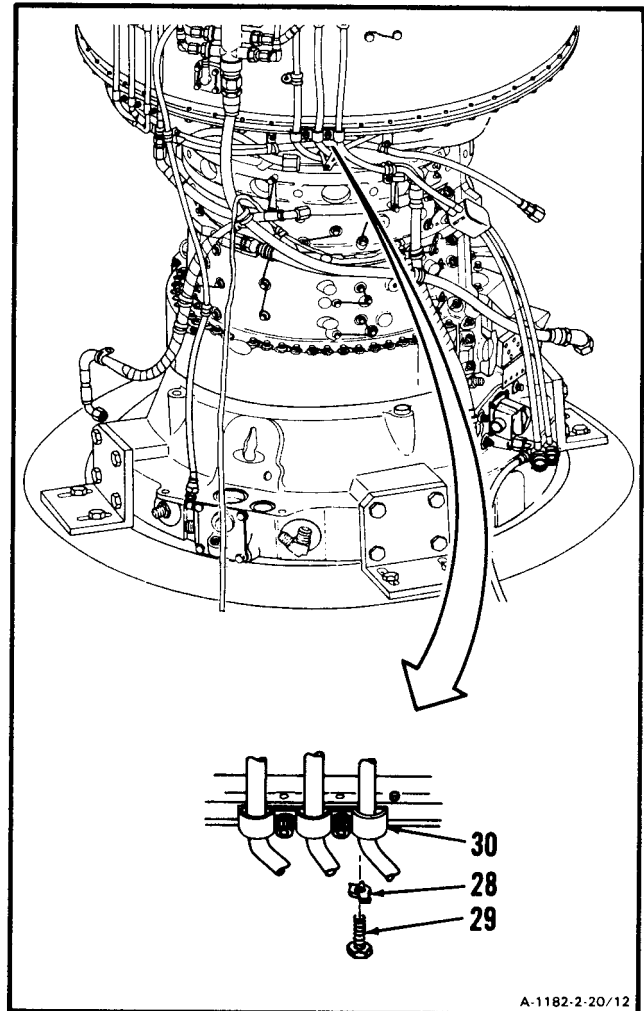

A-1182-2-20/12

GO TO NEXT PAGE

2-20 REMOVE LOWER COMPRESSOR HOUSING (Continued)

2-20

12. Disconnect hose assembly (31).

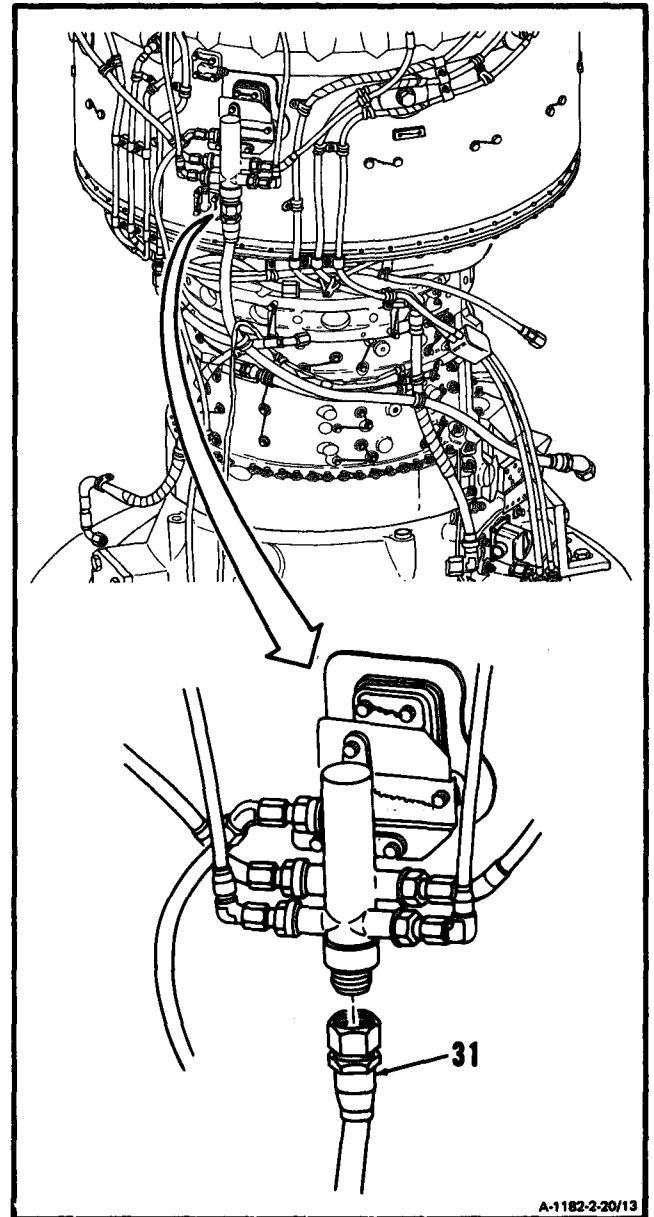

GO TO NEXT PAGE

13. **Disconnect hose assembly (32).**

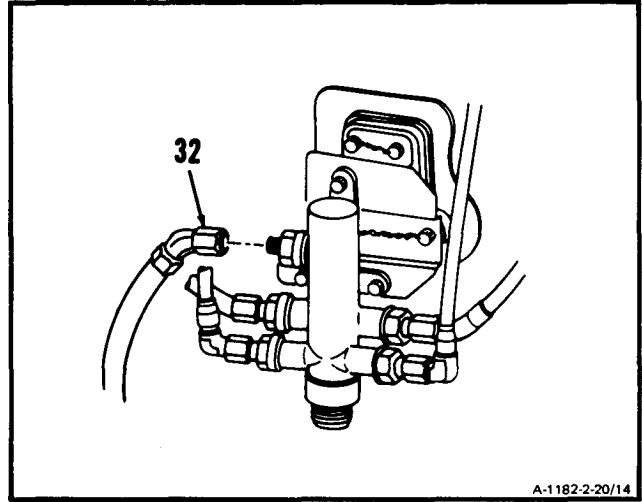

GO TO NEXT PAGE

14. Remove nut (33), screw (34), and two clamps (35).

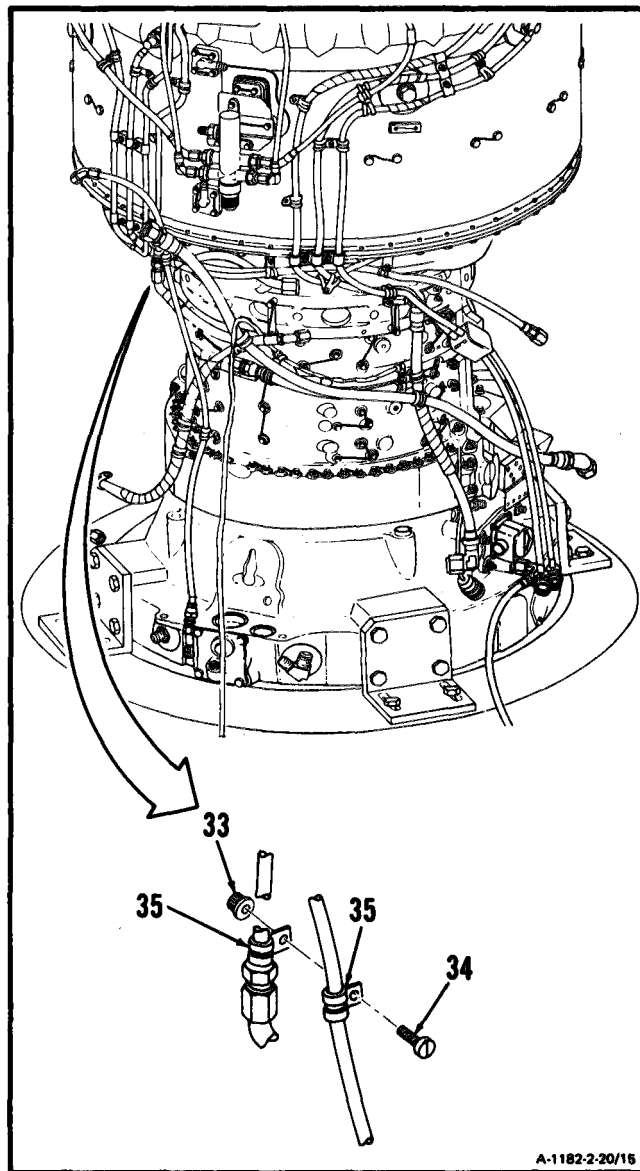

A-1182-2-20/16

GO TO NEXT PAGE

15. **Remove** lockwire, screw (36), and two **clamps** (37).

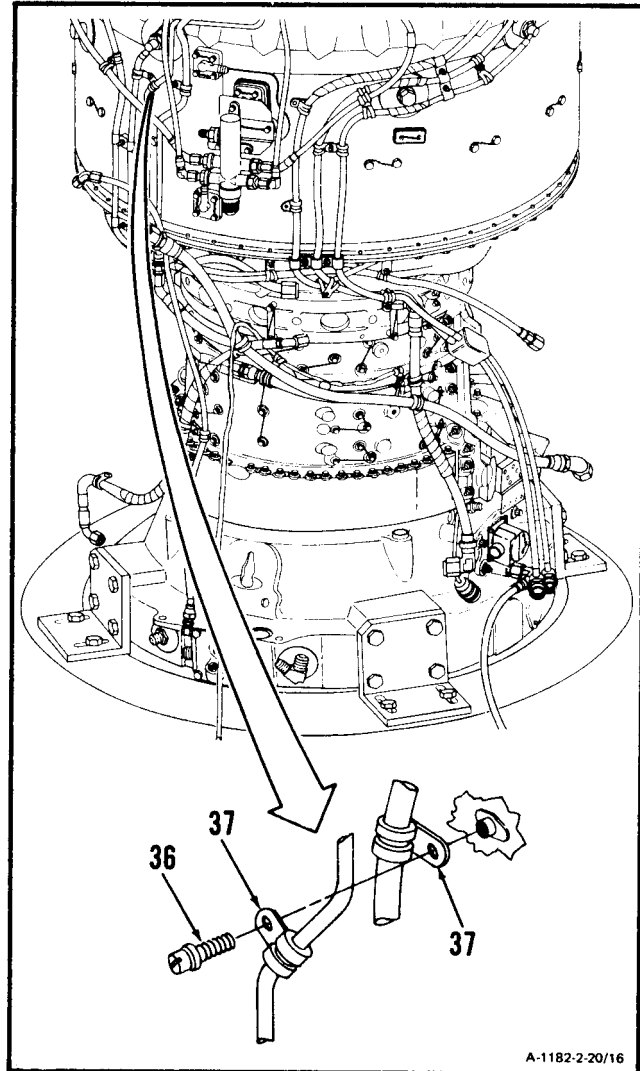

A-1182-2-20/16

GO TO NEXT PAGE

2-20 REMOVE LOWER COMPRESSOR HOUSING (Continued)

2-20

16. **Remove** lockwire, screw (38), and **clamp (39)**.

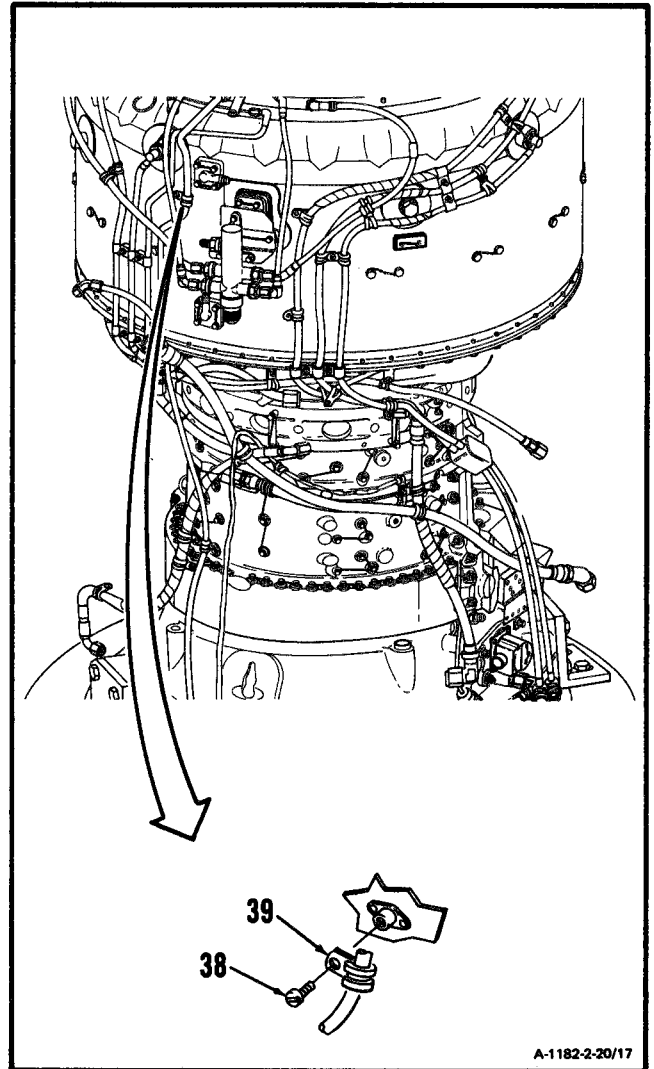

GO TO NEXT PAGE

17. Disconnect hose assembly (40).

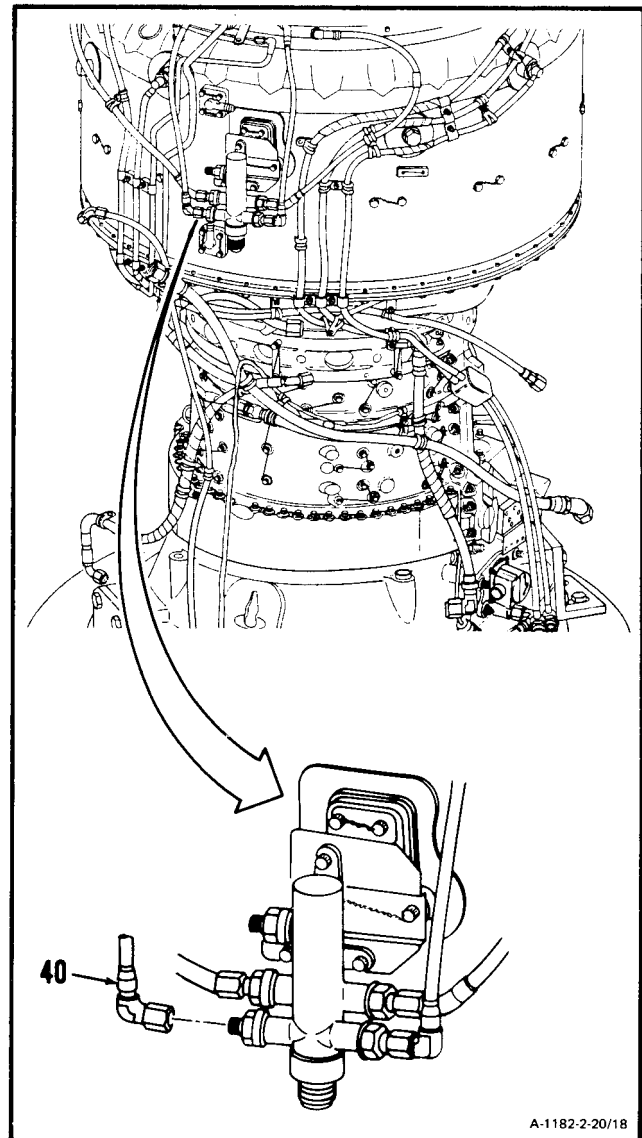

A-1182-2-20/18

GO TO NEXT PAGE

18. Disconnect hose assembly (41).

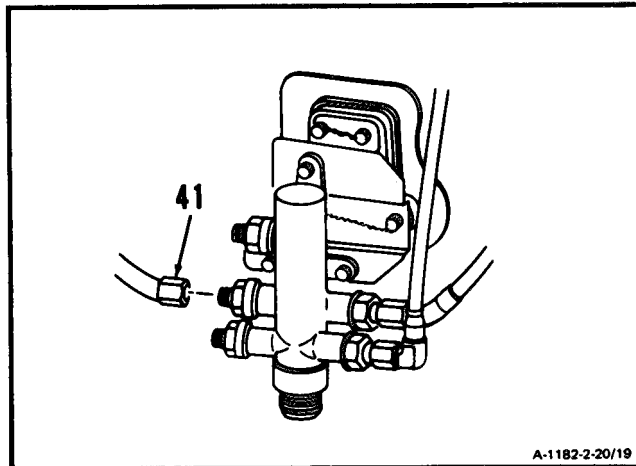

19. Disconnect hose assembly (42).

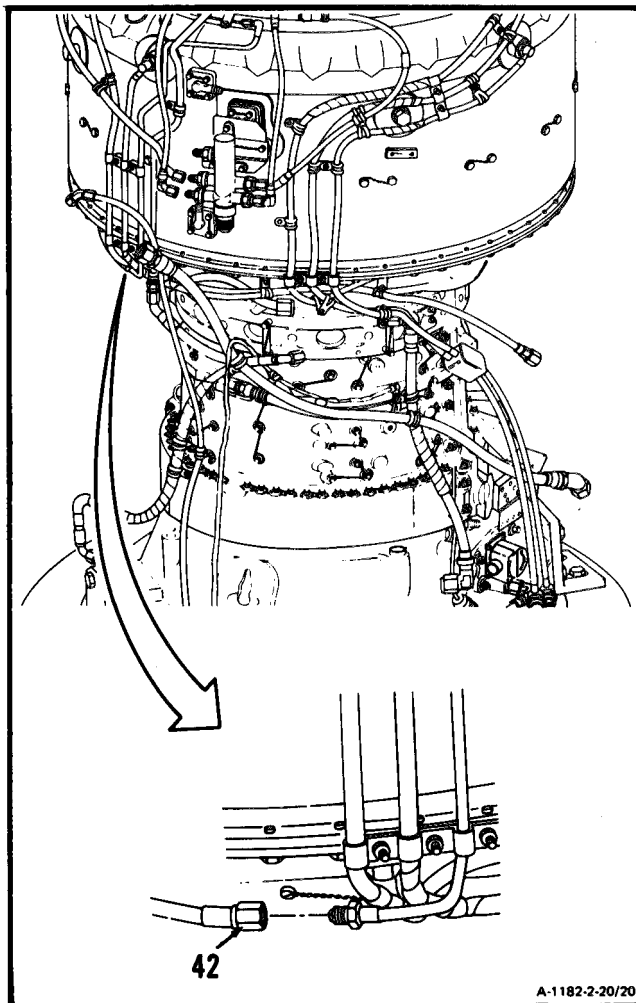

GO TO NEXT PAGE

20. Remove three nuts (43) and clamp (44).

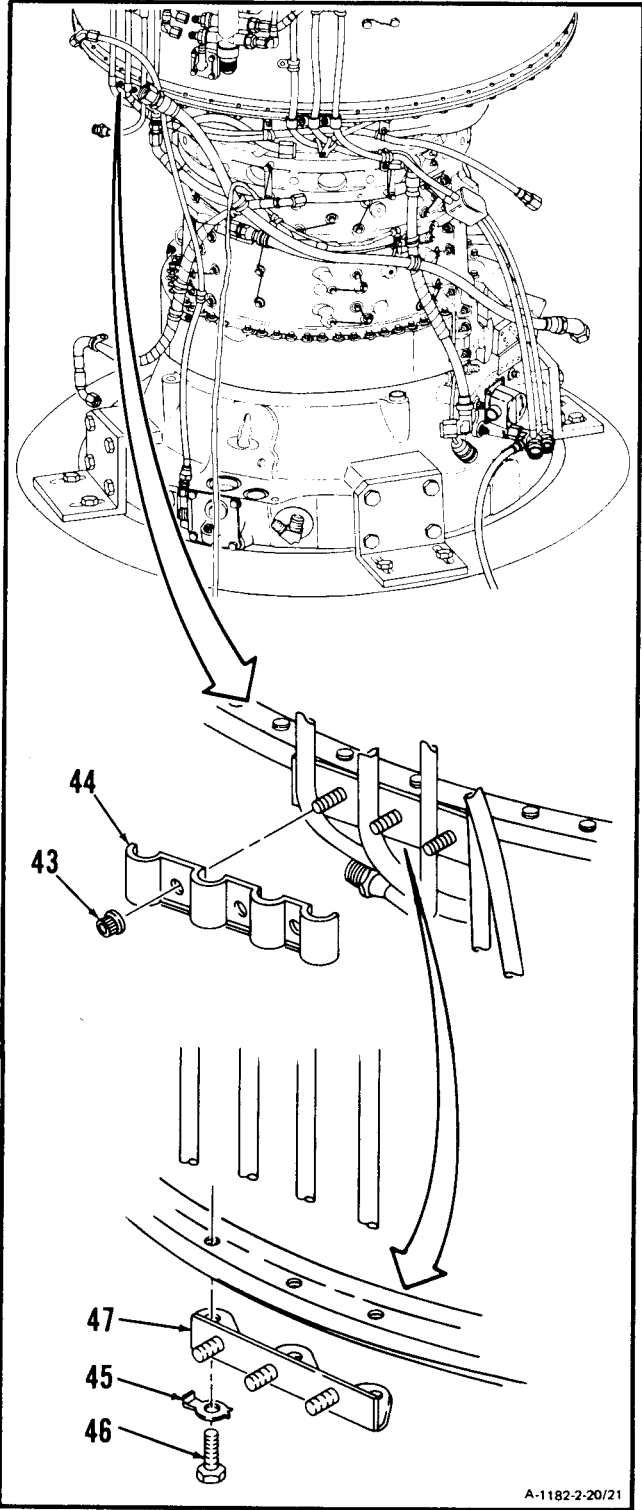

21. Bend tabs of three key washers (45). Remove three bolts (46), key washers (45), and bracket (47).

GO TO NEXT PAGE

22. Disconnect hose assembly (48).

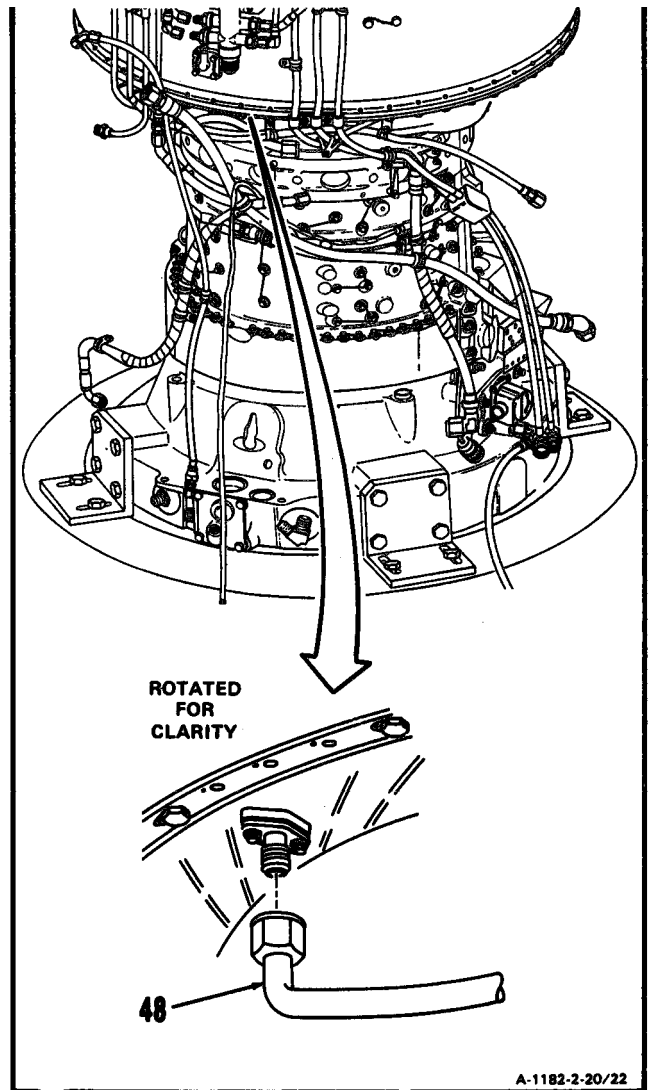

23. Remove lockwire, two bolts (49), adapter (50), and packing (51).

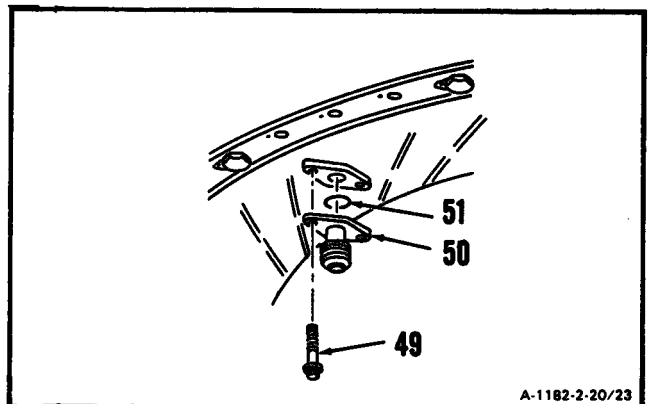

GO TO NEXT PAGE

24. **Remove** lockwire, and **bolt (52)**.
25. Remove lockwire and loosen bolt (53) and swing bracket (55) away from housing splitline (56).
Remove spacer (54).

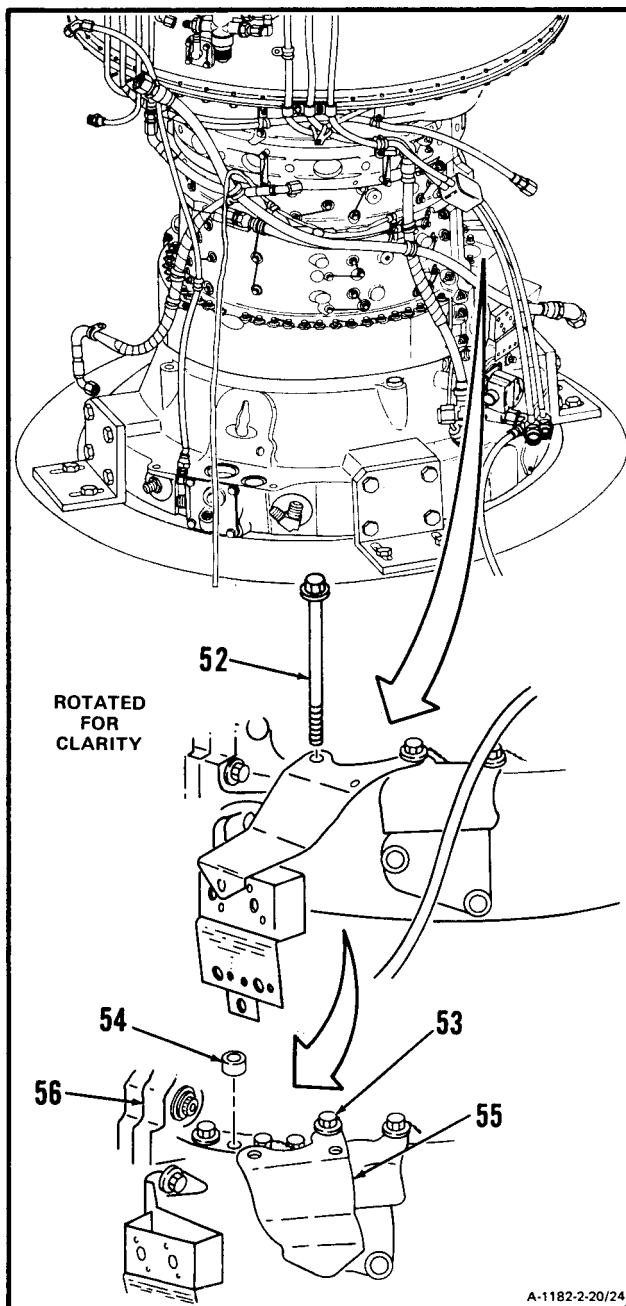

GO TO NEXT PAGE

2-20 REMOVE LOWER COMPRESSOR HOUSING (Continued)

2-20

26. Remove lockwire, bolt (57), and washer (58).

27. Remove two nuts (59), washers (60), bolts (61), bracket (62), and spacers (63).

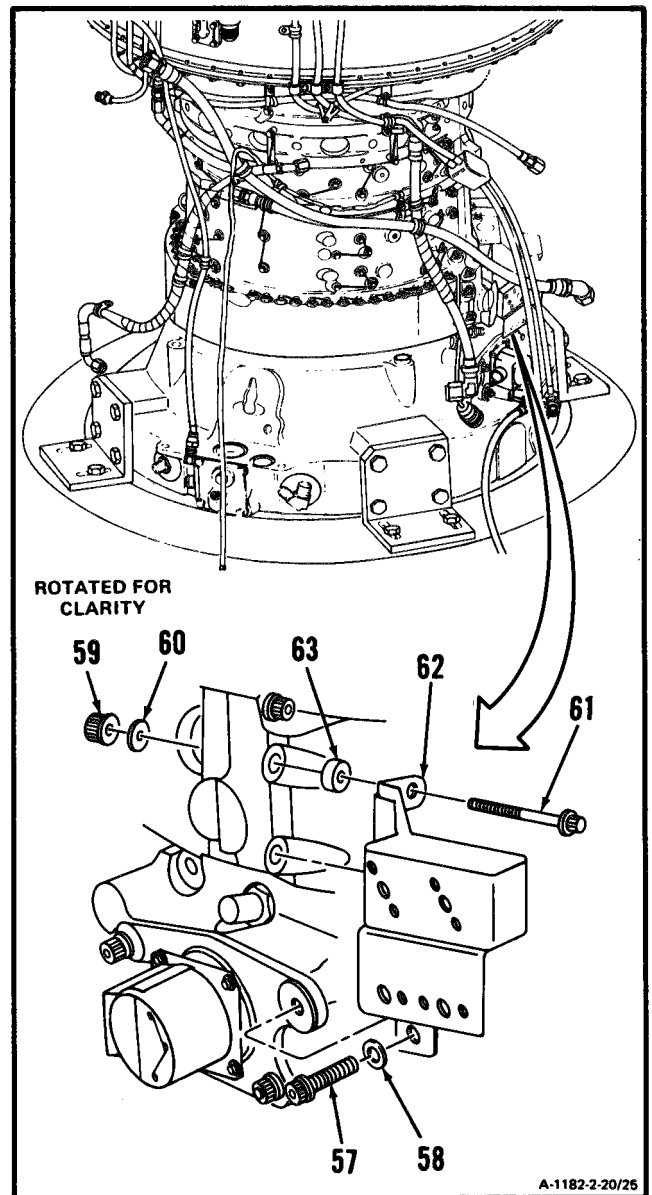

GO TO NEXT PAGE

28. Remove two nuts (64), two bolts (65), and four clamps (66).

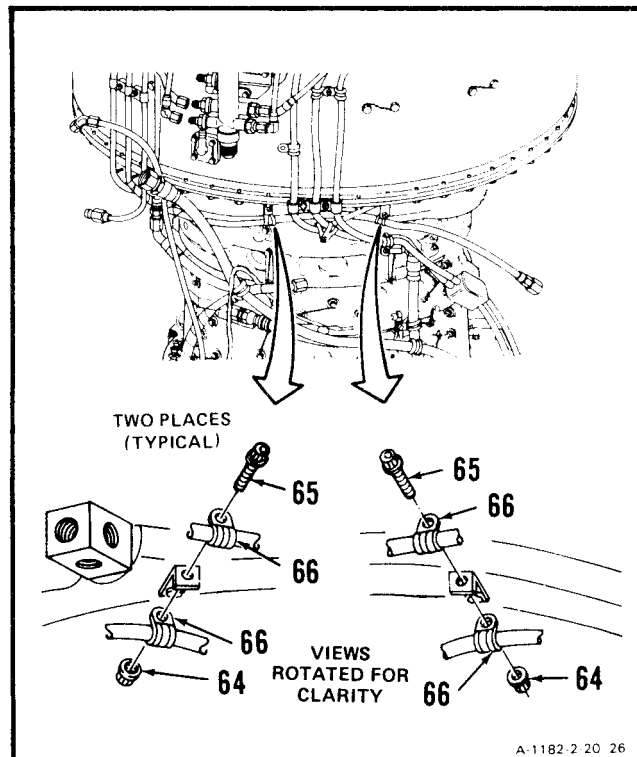

GO TO NEXT PAGE

2-20 REMOVE LOWER COMPRESSOR HOUSING (Continued)

2-20

NOTE

If lockwire is disturbed when disconnecting hose in following step, remove lockwire.

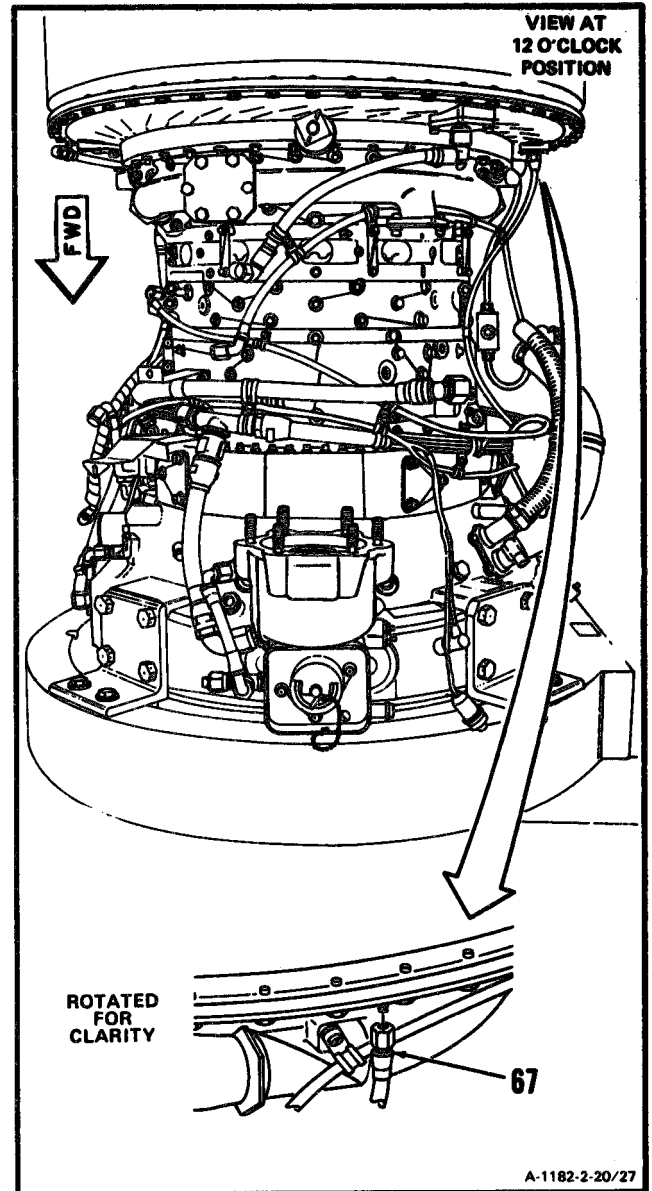
29. Disconnect hose assembly (67).**GO TO NEXT PAGE**

30. **Remove** lockwire, screw (68), and **clamp (69)**.

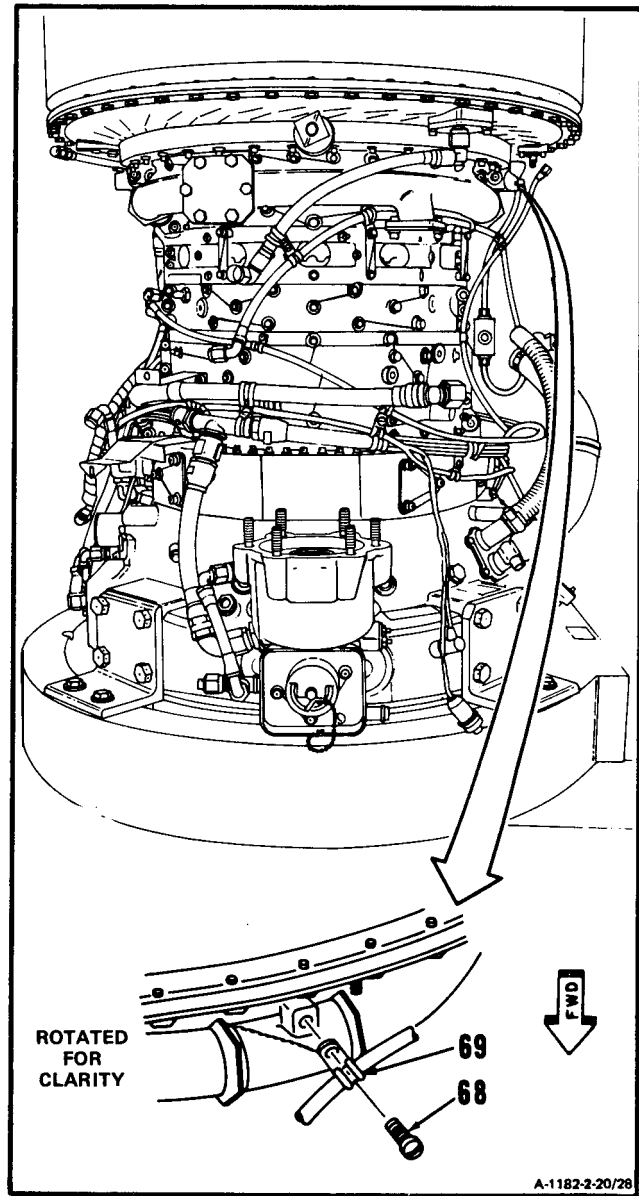

GO TO NEXT PAGE

2-20 REMOVE LOWER COMPRESSOR HOUSING (Continued)

31. Remove two nuts (70), washers (71), **bolts (72)**, and spacers (73).
32. Remove **solenoid valve (74)**, hose assembly (75, 76, and 77), and bracket (78) as an assembly.

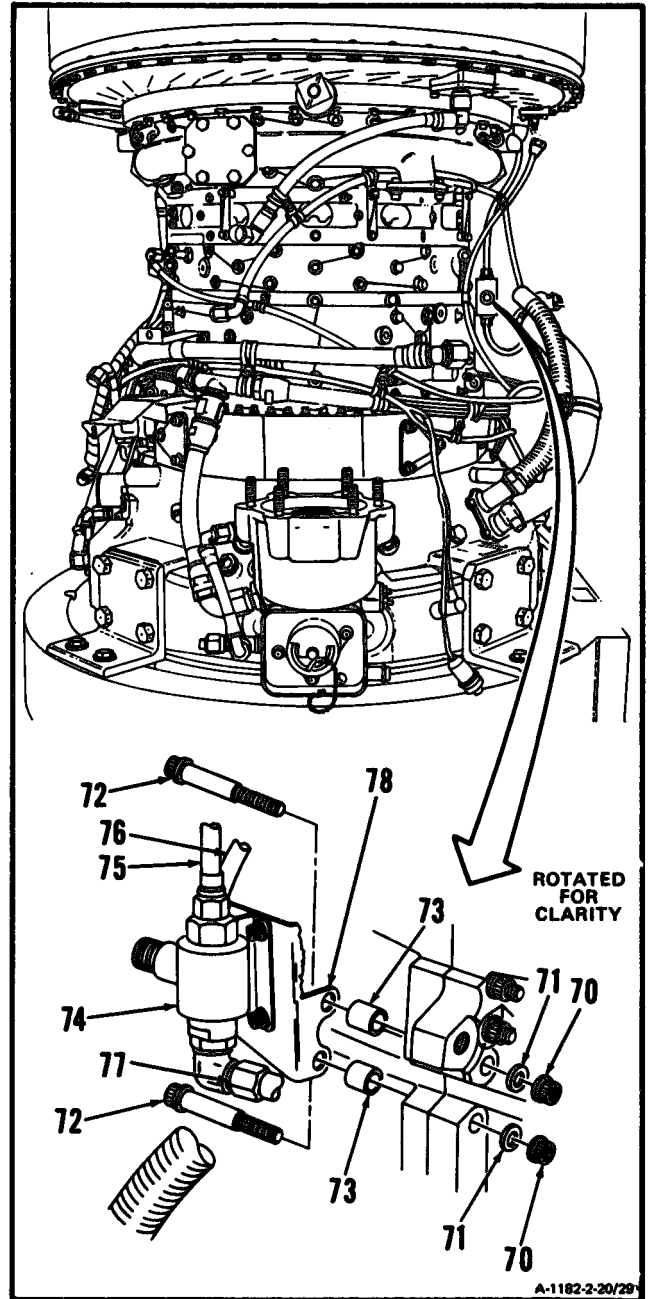

GO TO NEXT PAGE

33. Remove lockwire and **disconnect nut (79)** from connector (80). Use padded conduit pliers.

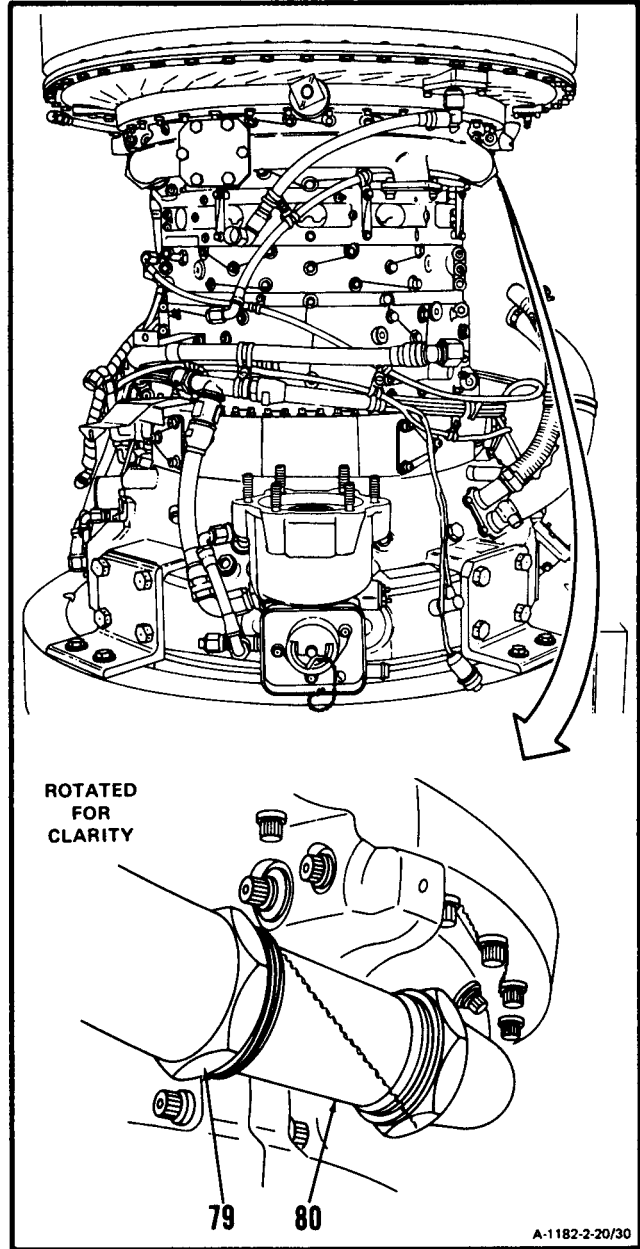

GO TO NEXT PAGE

2-20 REMOVE LOWER COMPRESSOR HOUSING (Continued)

2-20

34. Remove lockwire and **disconnect nut (81)** from connector (80). Use padded conduit pliers.

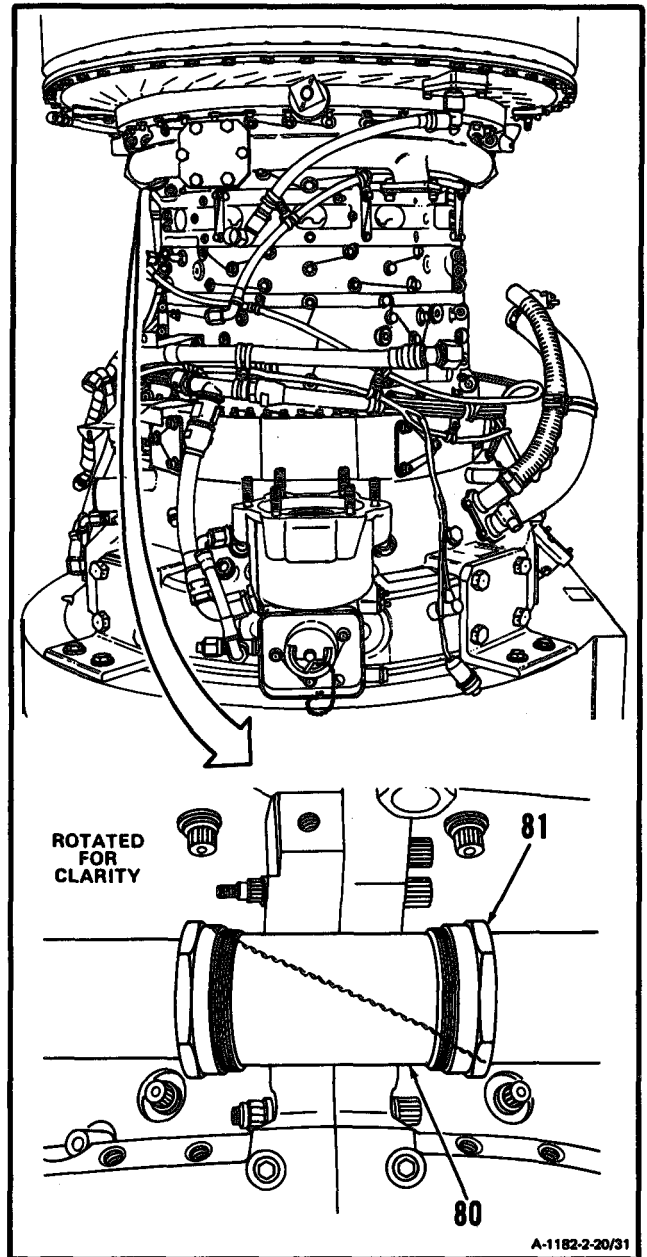

GO TO NEXT PAGE

35. Remove lockwire, four bolts (82) and washers (83).

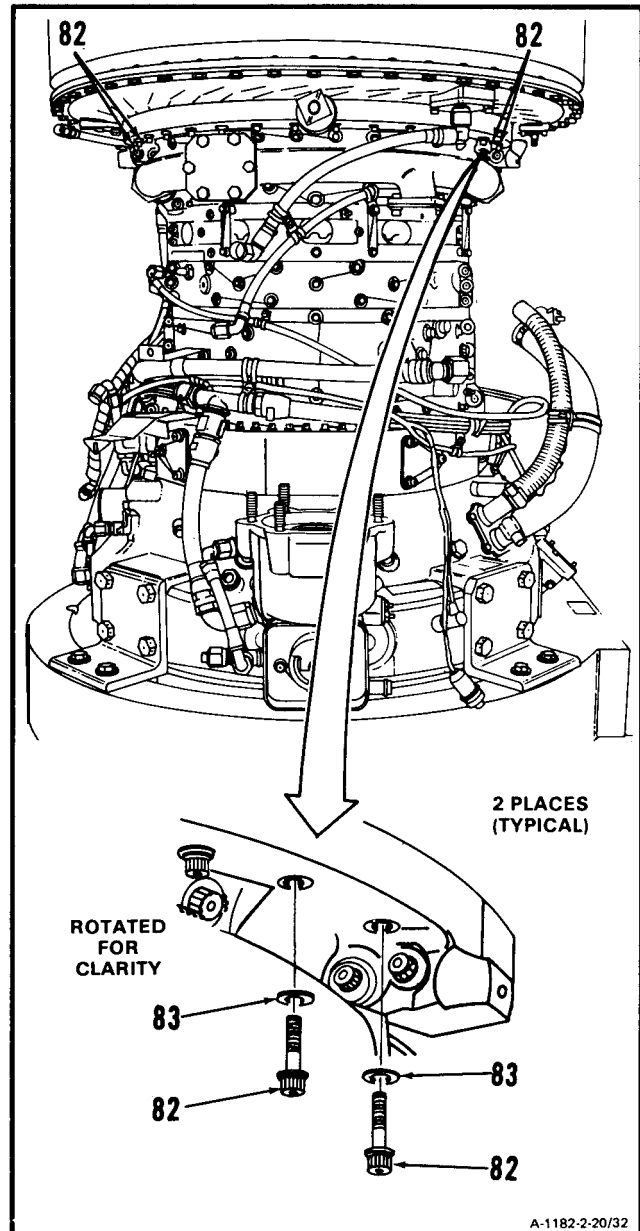

GO TO NEXT PAGE

2-20 REMOVE LOWER COMPRESSOR HOUSING (Continued)

2-20

NOTE

Procedure for removing nuts, bolts, and washers from four dowel pins is the same.

- 36 **Remove** four nuts (84), washers (85), and bolts (86) from dowel pins (87).

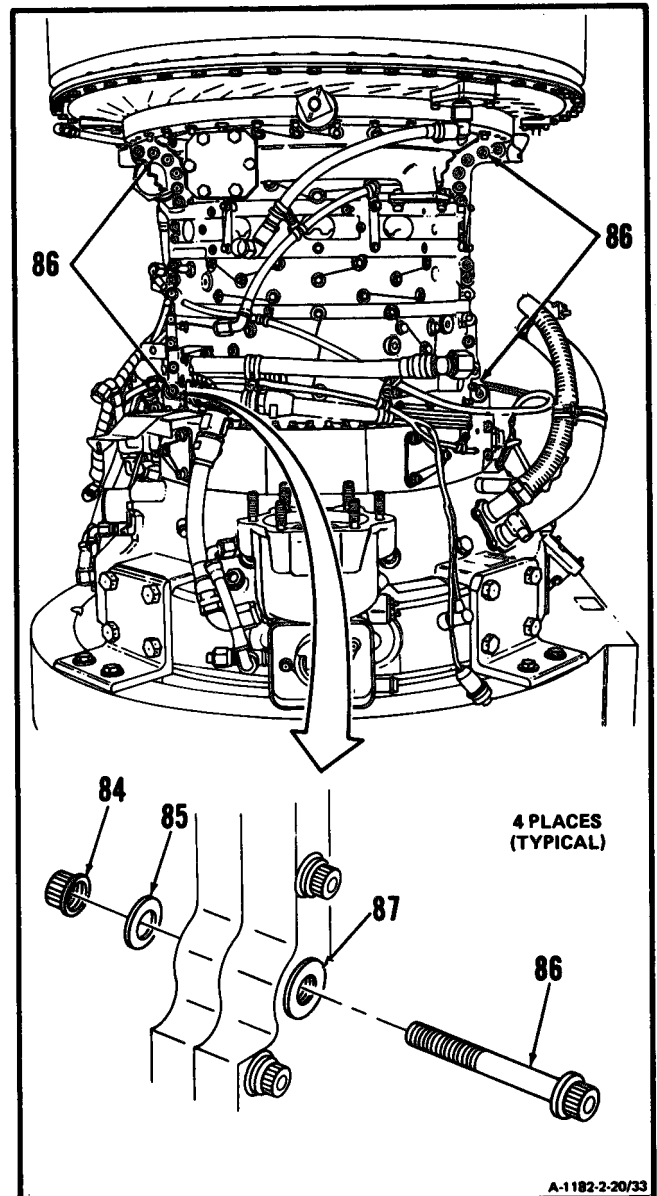

GO TO NEXT PAGE

NOTE

Procedure for removing four dowel pins is the same. Procedure for only one is shown.

37. Thread mechanical puller (T6) (88) into dowel pin (87).

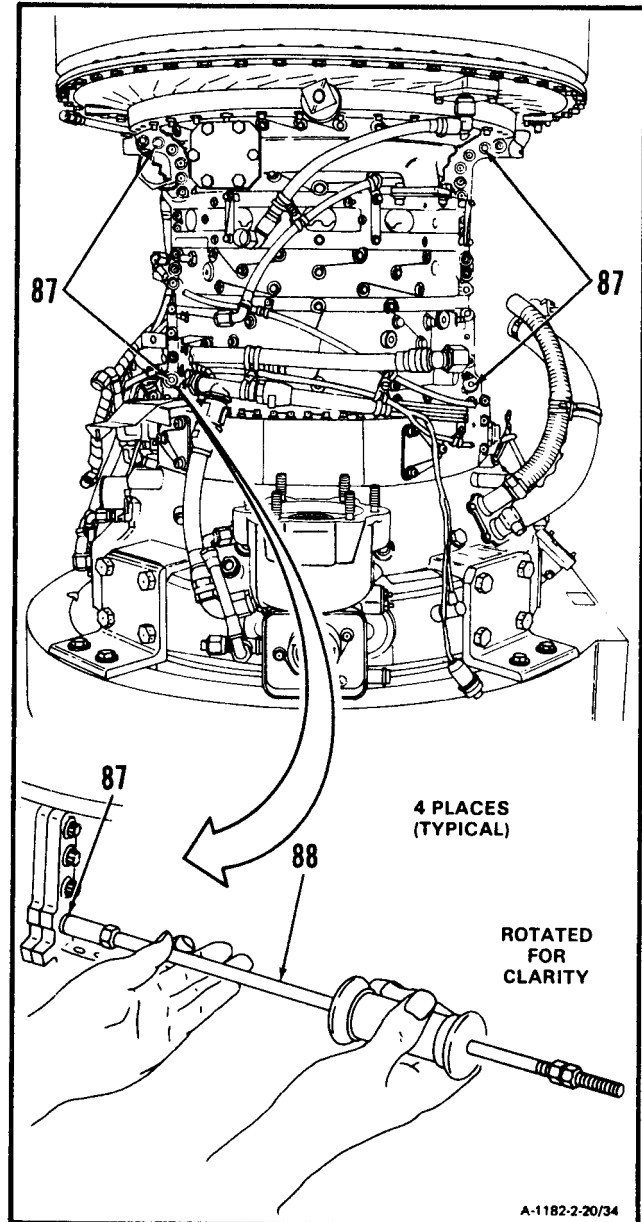

GO TO NEXT PAGE

2-20 REMOVE LOWER COMPRESSOR HOUSING (Continued)

2-20

38. Slide mechanical puller handle (89) up against nuts (90) and **remove dowel pin (87)**.
39. Remove dowel pin (87) from mechanical puller (T6) (88).

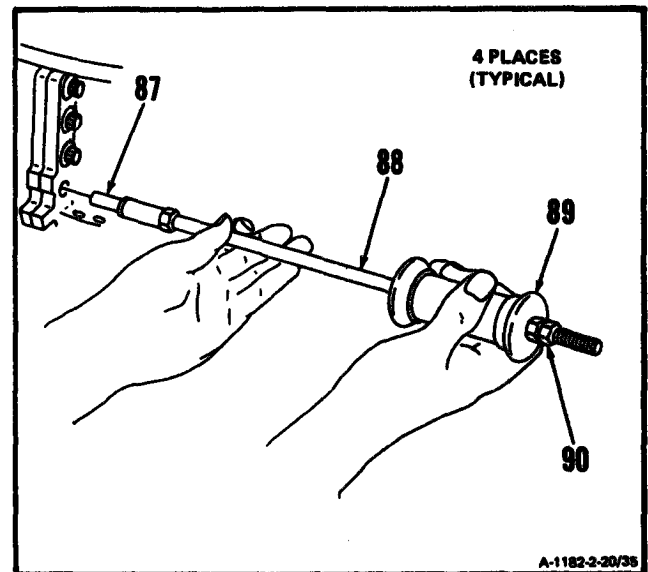
**GO TO NEXT PAGE**

40. **Remove** lockwire, two bolts (91), washers (92), and **brackets (93)**.

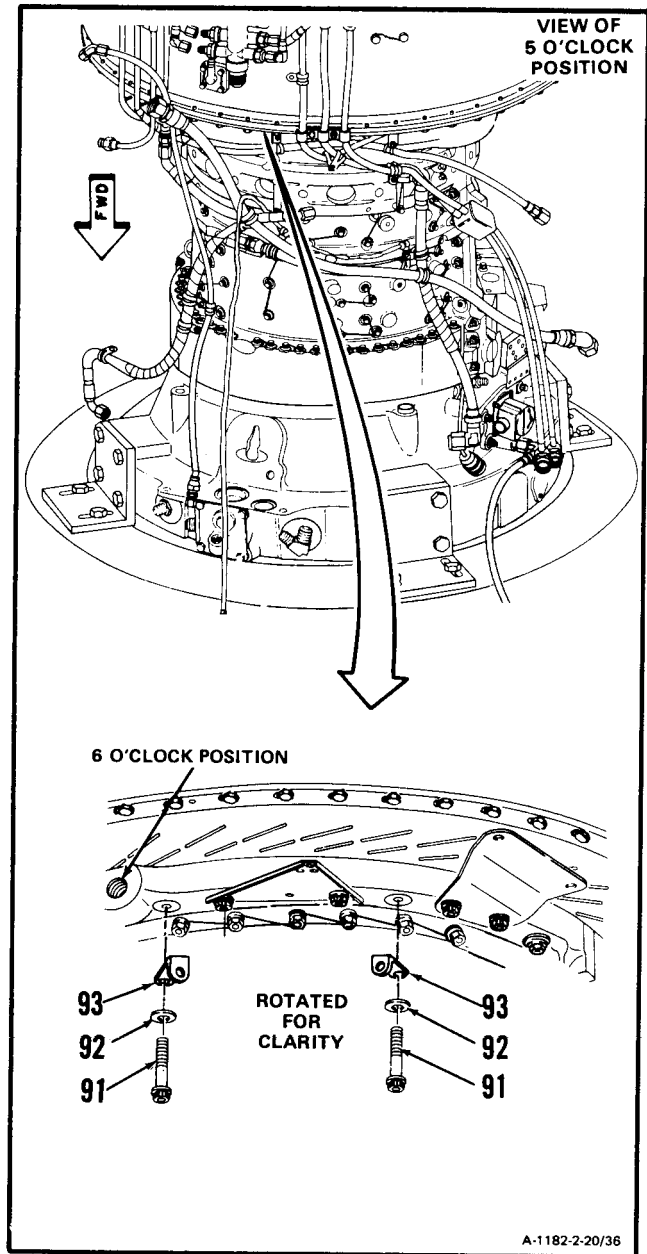

GO TO NEXT PAGE

2-20 REMOVE LOWER COMPRESSOR HOUSING (Continued)

2-20

41. **Remove** lockwire, 14 bolts (94), washers (95), and brackets (96 and 97).

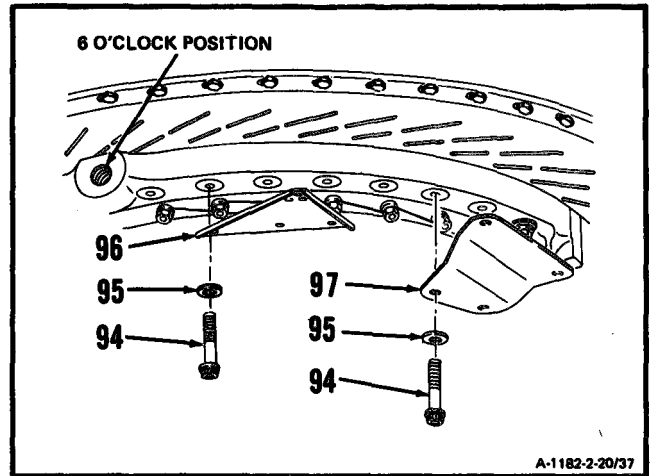

42. **Remove** lockwire, 27 bolts (98) and washers (99).

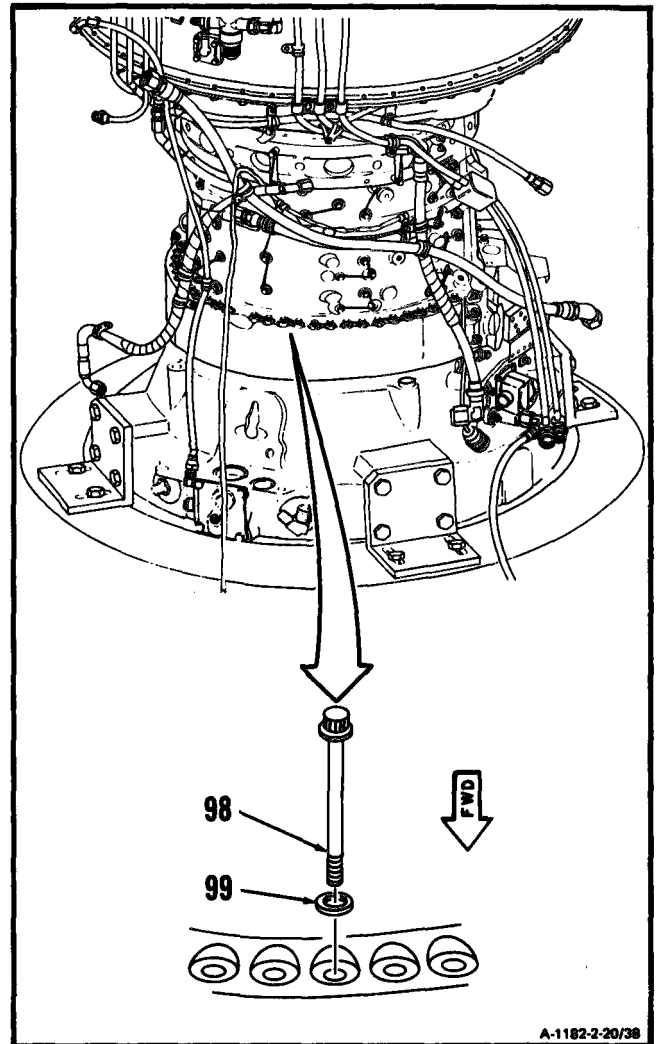

GO TO NEXT PAGE

43. **Remove** two nuts (100), four washers (101), and **two bolts (102).**

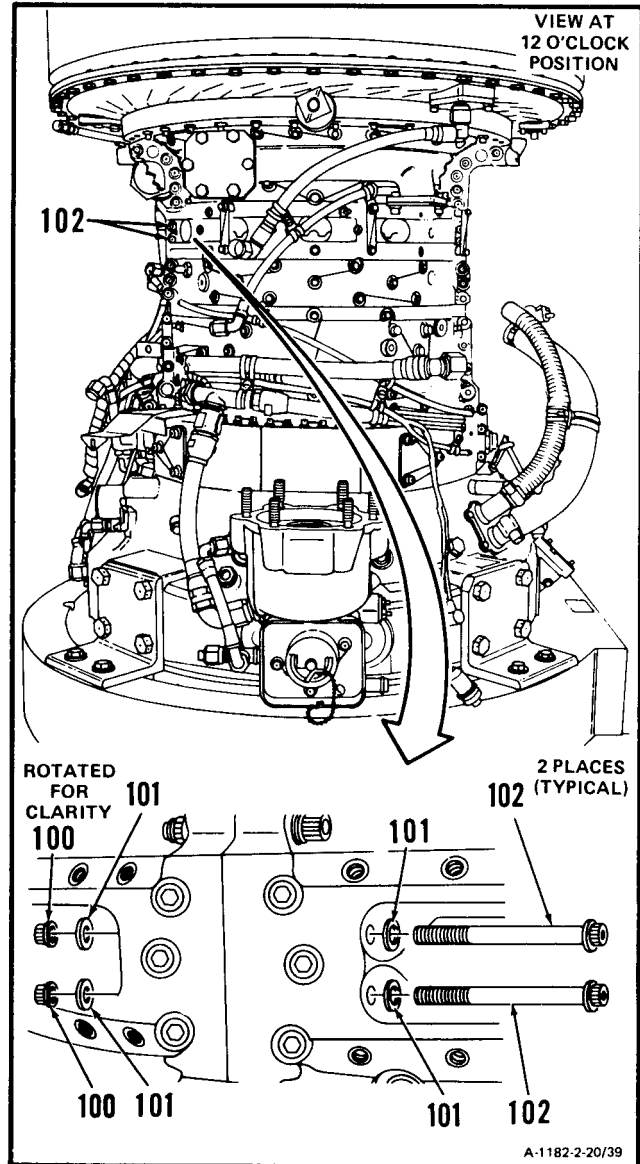

GO TO NEXT PAGE

2-20 REMOVE LOWER COMPRESSOR HOUSING (Continued)

2-20

44. Remove lockwire, two bolts (103) and bleed band retainer (104).

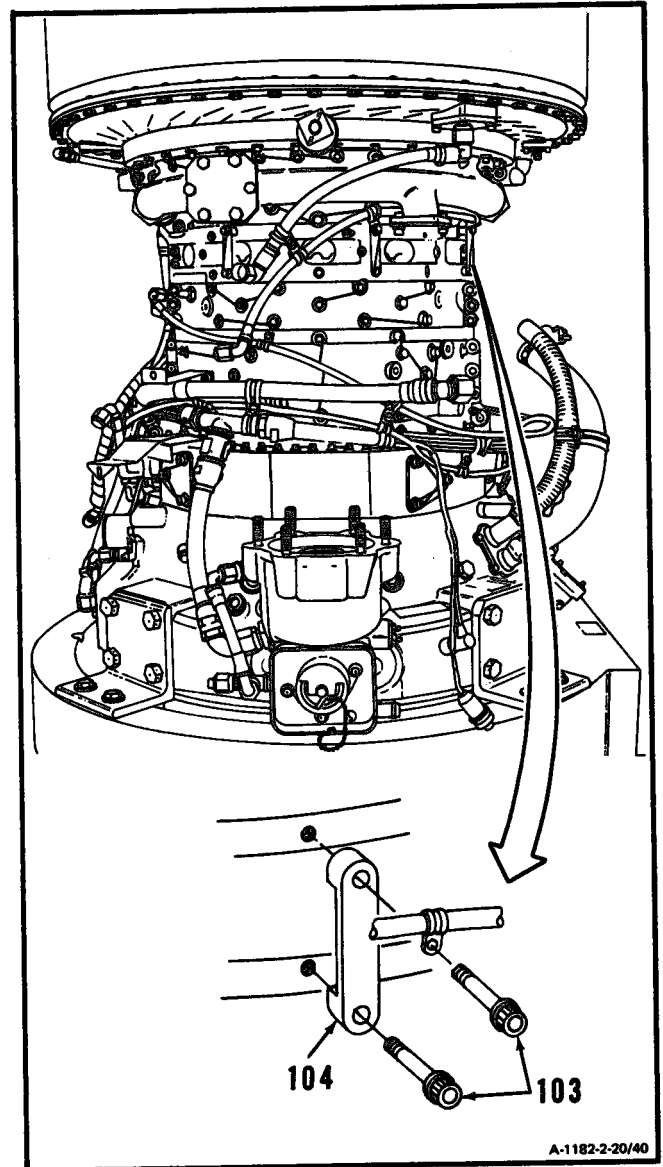

A-1182-2-20/40

GO TO NEXT PAGE

45. Remove two nuts (105), four washers (106) and two bolts (107).

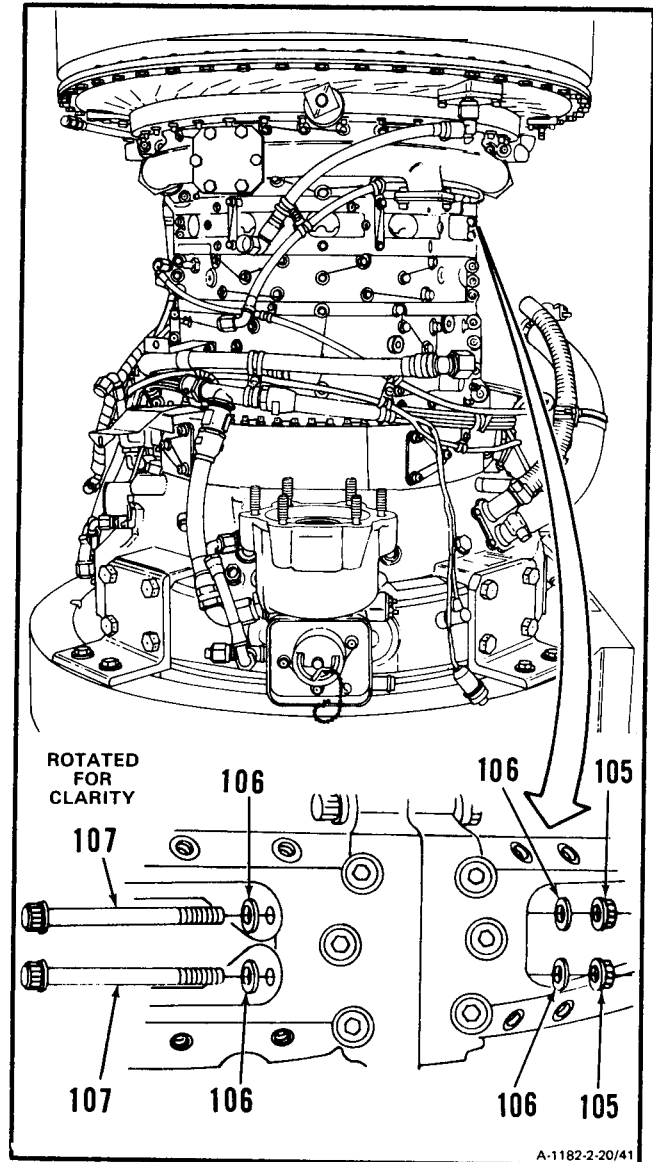

A-1182-2-20/41

GO TO NEXT PAGE

2-20 REMOVE LOWER COMPRESSOR HOUSING (Continued)

2-20

46. **Remove** three nuts (108), six washers (109), and **three bolts** (110).

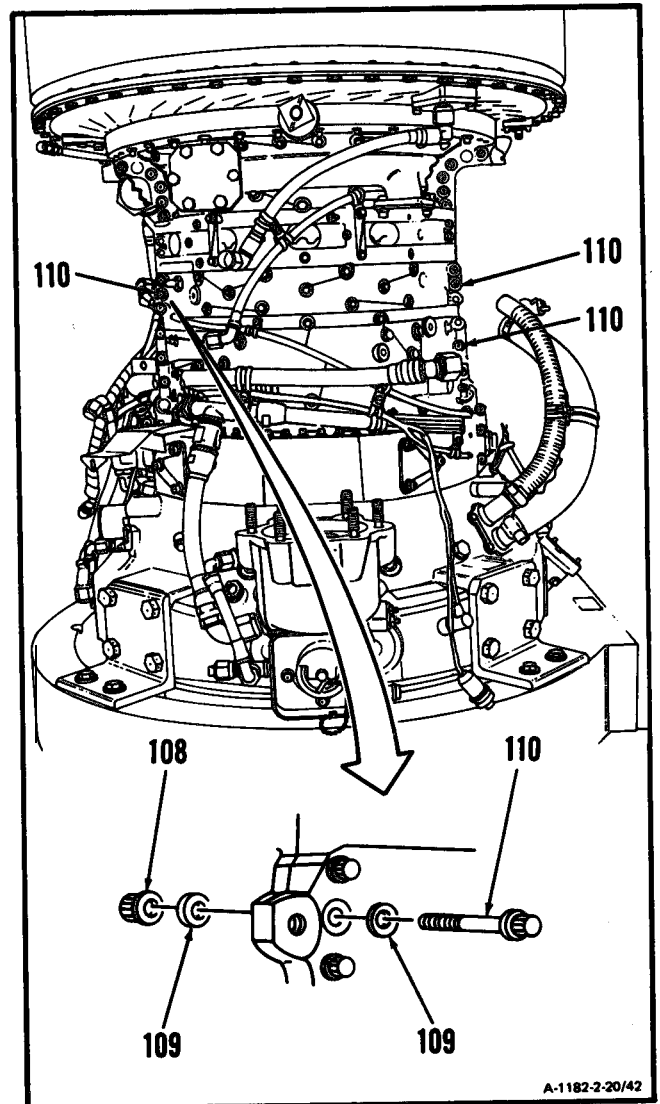

GO TO NEXT PAGE

47. Remove 21 nuts (111), 42 washers (112) and 21 bolts (113).

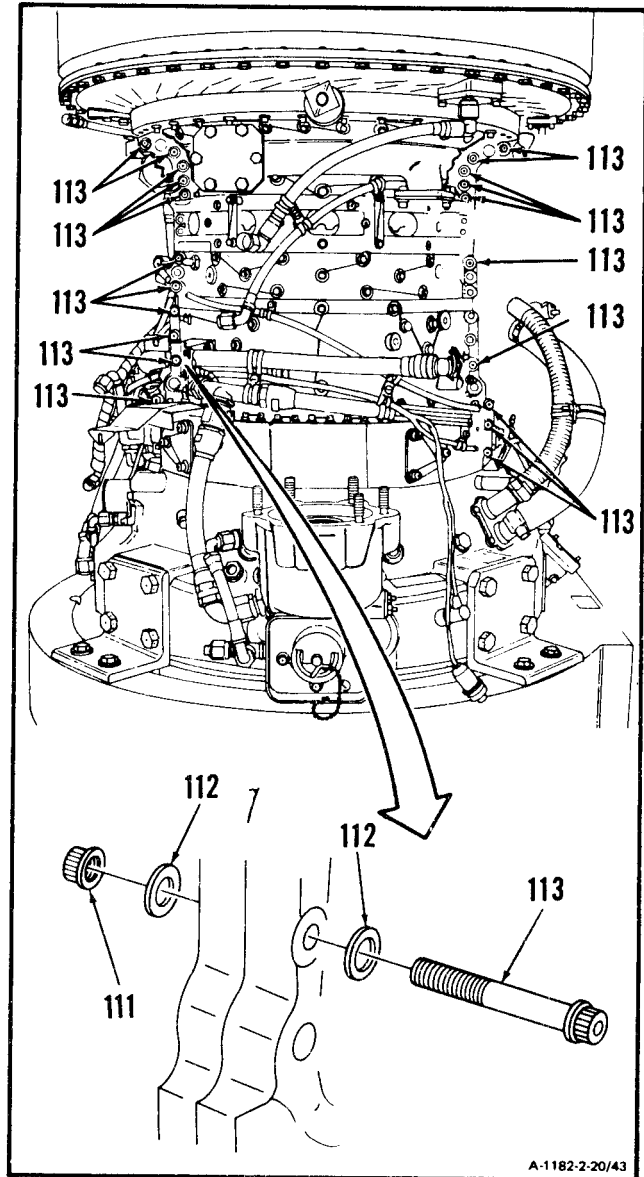

GO TO NEXT PAGE

2-20 REMOVE LOWER COMPRESSOR HOUSING (Continued)

2-20

48. Have helper lift upon combustion section and power turbine (114) and remove lower compressor housing (115).

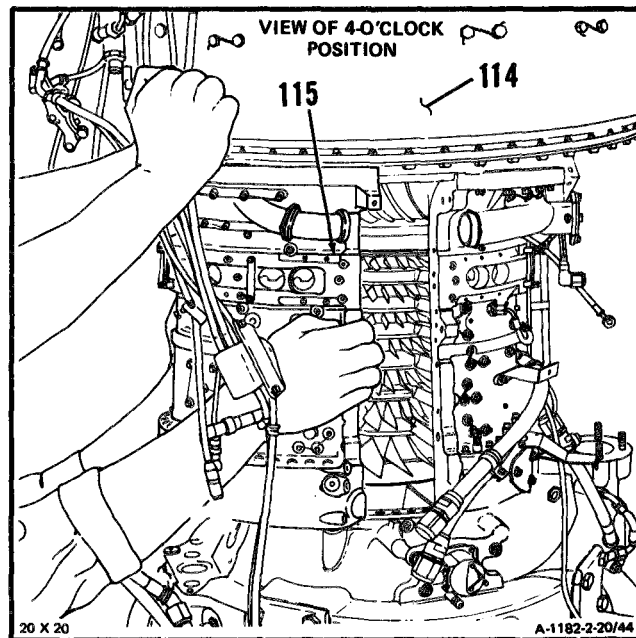

FOLLOW-ON MAINTENANCE:

None

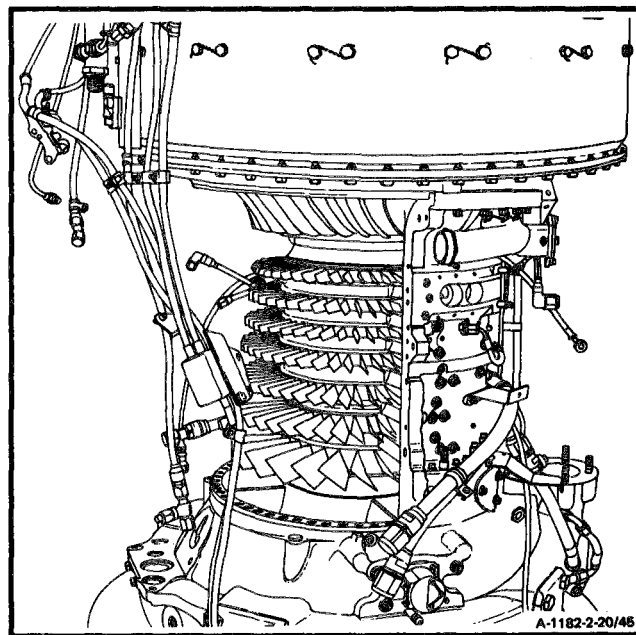

END OF TASK

INITIAL SETUP**Applicable Configurations:**

All

Tools:Powerplant Mechanic's Tool Kit,
NSN 5180-00-323-4944

Goggles

Compressed Air Source

Fiber Brush

Materials:

Dry Cleaning Solvent (E17)

Gloves (E20)

Personnel Rewired:

68B10 Aircraft Powerplant Repairer

Equipment Condition:

Engine Oil System Drained (Task 1-75)

Oil Cooler Assembly Removed (Task 8-5)

In-Line Fuel Filter Assembly Removed
(Task 6-36)

Ignition Exciter Removed (Task 7-11)

Oil Filler Assembly and Oil Filler Strainer Re-
moved (Task 8-16) (Upper Compressor
Housing Only)Starter Drive Assembly Removed (Task 5-12)
(Upper Compressor Housing Only)Main Fuel Filter and Bracket Removed
(Task 6-29)Dual Chip Detector Removed (Task 8-28)
(Lower Compressor Housing Only)Fuel Boost Pump Assembly Removed
(Task 6-9) (Lower Compressor Housing
Only)Tube Assembly (Inlet Housing to Main Oil
Pump Removed (Task 8-50) (Lower
Compressor Housing Only)Main Oil Pump and Scavenge Oil Screen Re-
moved (Task 8-1) (Lower Compressor
Housing Only)Fuel Control Removed (Task 6-1) (Lower
Compressor Housing Only)Accessory Gearbox Removed (Task 5-1)
(Lower Compressor Housing Only)Interstage Air-Bleed Actuator Removed
(Task 2-1)Compressor Bleed Band Removed (Task
2-9)Compressor Housing Removed (Task 2-19
or 2-20)**General Safety Instructions:****WARNING**

Dry cleaning solvent (E17) is flammable and toxic. It can irritate skin and cause burns. Use only in well-ventilated area, away from heat and open flame. In case of contact, immediately flush skin or eyes with water for at least 15 minutes. Get medical attention for eyes.

GO TO NEXT PAGE

NOTE

The following procedure applies to both (upper and lower) compressor halves.

1. Wear gloves (E20), and **clean compressor housing (1) and stator vanes (2)**. Use fiber brush and dry cleaning solvent (E17).

WARNING

When using compressed air for cleaning, use approved protective equipment for eyes and face. Do not use more than **30 psig** air pressure. Do not direct air toward yourself or another person. Failure to comply could result in injury to eyes or skin. In case of injury, get medical attention.

2. Wear goggles. **Blow dry compressor housing (1) and stator vanes (2)** using clean, dry compressed air.

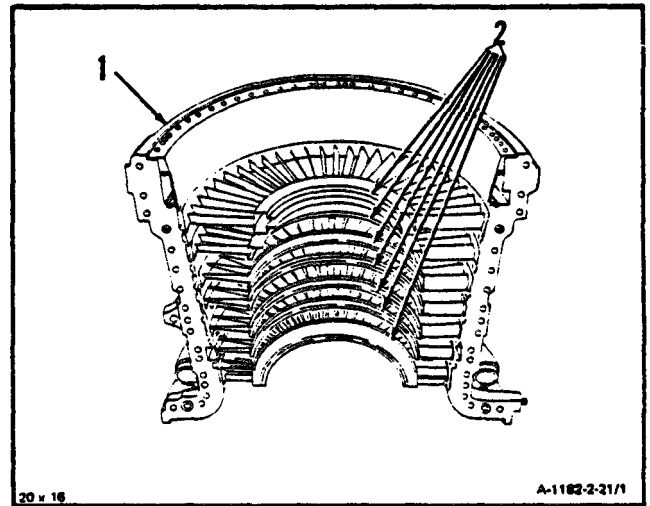
**FOLLOW-ON MAINTENANCE:**

Inspect Compressor Housing (Task 2-22).

END OF TASK

2-22 INSPECT COMPRESSOR HOUSING

2-22

INITIAL SETUP

Applicable Configurations:

All

Tools:

Technical Inspector's Tool Kit,
NSN 5180-00-3235114

Materials:

None

Personnel Required:

68B30 Aircraft Powerplant Inspector

References:

Task 2-28

Equipment Condition:

Off Engine Task
Stator Vane Assemblies Removed
(Task 2-26)

NOTE

The following procedure applies to both (upper and lower) compressor halves.

1. Inspect compressor housing (1) as follows:

- a. There shall be no cracks.
- b. There shall be no nicks, dents or gouges greater than 0.500 inch length to 0.070 inch depth.
- c. There shall be no corrosion or paint damage.
- d. There shall be no RTV residue on mounting surface of first stage stator vane assembly (1-1).

2. Inspect seven inserts (2) as follows:

- a. There shall be no blade tip rubs.
- b. There shall be no looseness.
- c. There shall be no cracks.
- d. Inspect bolt ends (3). Both ends shall be flush, or not more than 0.035 inch below surface of inserts (2).

3. Inspect stator vane assemblies (Ref. Task 2-28).

FOLLOW-ON MAINTENANCE:

Install Stator Vane Assemblies (Task 2-30).

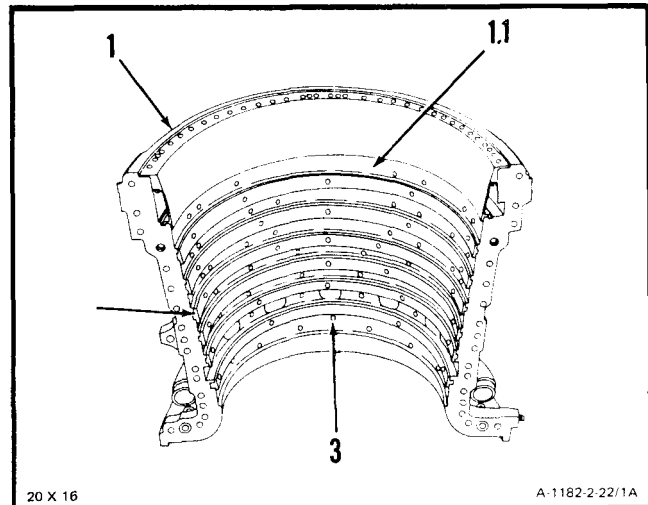
END OF TASK

2-23 REPAIR COMPRESSOR HOUSING

2-23

INITIAL SETUP

Applicable Configurations:

All

Tools:

Technical Inspection Tool Kit,
NSN 51830-00-323-5114

Materials:

Acid Swabbing Brush (E2)
Carborundum Stone (E10)
Crocus Cloth (E15)
Engine Gray Enamel (E22)

Personnel Required:

68B10 Aircraft Powerplant Repairer
68B30 Aircraft Powerplant Inspector

References:

Task 1-119

Equipment Condition:

Off Engine Task
Stator Vane Assemblies Removed (Task 2-26)

NOTE

The following procedures apply to both (upper and lower) compressor halves.

- 1, Repair nicks, dents and gouges on inside and outside diameter of compressor housing (1) as follows:
 - a. Defects of 0.070 inch depth shall not be opposite each other on the inside and outside diameter of housing (1).
 - b. Defects shall not project into mating surfaces.
 - c. **Repair gouges** up to 0.500 inch length to 0.070 inch depth.
 - (1) Blend all sharp edges using Carborundum stone (E10).
 - (2) Polish to smooth finish using crocus cloth (E15).
 - d. **Repair dents** up to 0.500 inch length to 0.070 inch depth.
 - (1) Blend all sharp edges using Carborundum stone (E10).
 - (2) Polish to smooth finish using crocus cloth (E15).

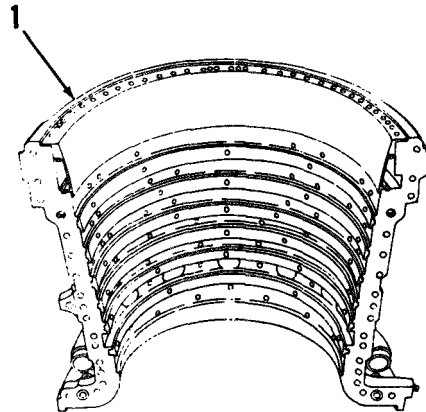
**GO TO NEXT PAGE**

- e. **Repair nicks** up to 0.500 inch length to 0.070 inch depth.
- (1) Blend all sharp edges using Carborundum stone (E10).
 - (2) Polish to smooth finish using crocus cloth (E15).
2. **Repair corrosion damage** up to 0.070 inch depth
- a. Blend all sharp edges using Carborundum stone (E10).
 - b. Polish to smooth finish using crocus cloth (E15).
 - c. Use touch-up procedure for magnesium and magnesium alloys (Ref. Task 1-1 19). Use engine gray enamel (E22).
3. **Repair damaged paint** on compressor housing
- (1). Use engine gray enamel (E22).

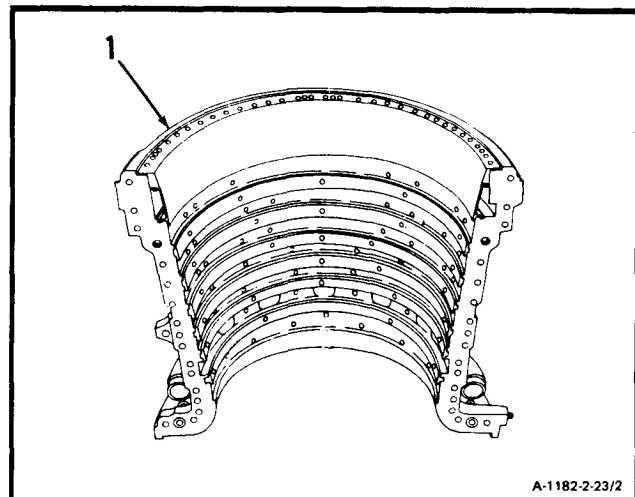

INSPECT

FOLLOW-ON MAINTENANCE:

Install Stator Vane Assemblies (Task 2-30).

END OF TASK

2-24 INSTALL UPPER COMPRESSOR HOUSING

2-24

INITIAL SETUP**Applicable Configurations:**

All

Tools:

Powerplant Mechanic's Tool Kit,
NSN 5180-00-323-4944
Technical Inspection Tool Kit,
NSN 5180-00-323-5114
Torque Wrench, 0-30 Inch-Pounds
Torque Wrench, 30-150 Inch-Pounds
Open-End Wrench, 1-5/8 Inch
Crowfoot Attachment (T66)

Materials:

Lockwire (E29)

Parts:

Packing

Personnel Required:

68B10 Aircraft Powerplant Repairer (2)
68B30 Aircraft Powerplant Inspector

References:

TM 55-2840-254-23P

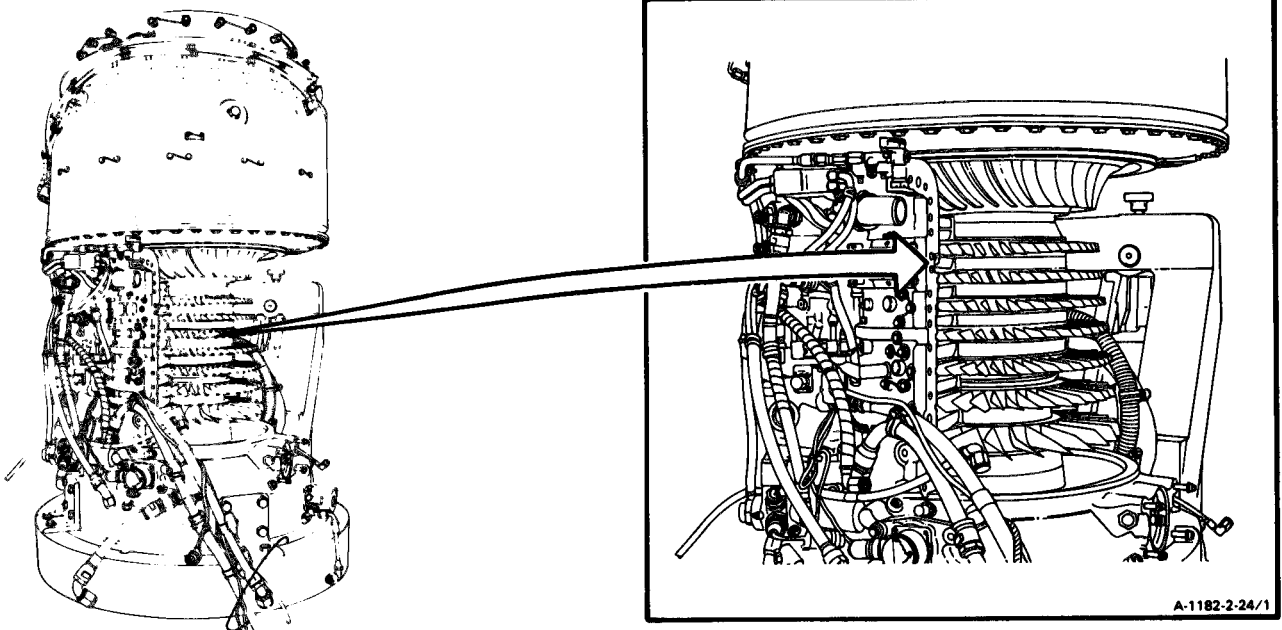
**GO TO NEXT PAGE**

NOTE

Some engine compressor housings may have provisions for a packing and plug installed at the 9-o'clock position. If required, assure installation.

1. Have helper lift up on combustion section and power turbine (1) and **install upper compressor housing (2)**. Align two connectors (3) with air gallery (4).

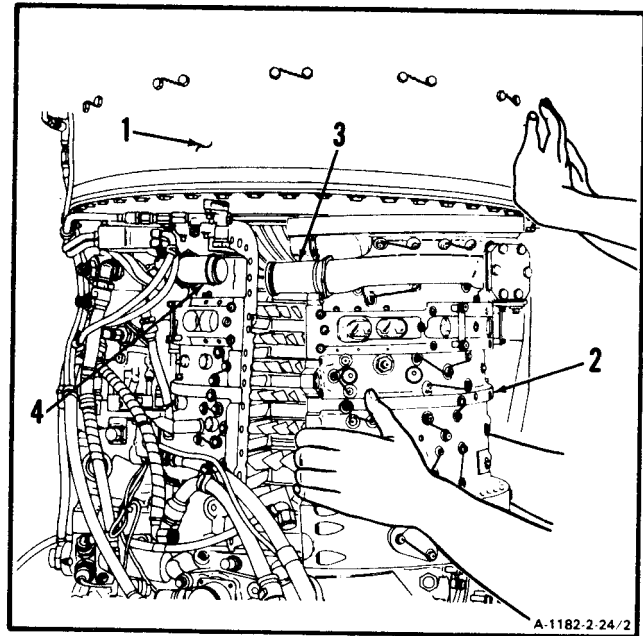

GO TO NEXT PAGE

2-24 INSTALL UPPER COMPRESSOR HOUSING (Continued)

2-24

NOTE

Procedure for installing four dowel pins is the same. Procedure for only one is shown.

2. Align dowel pin (5) with hole (6) and **tap in dowel pin (5)**. Use soft face mallet.

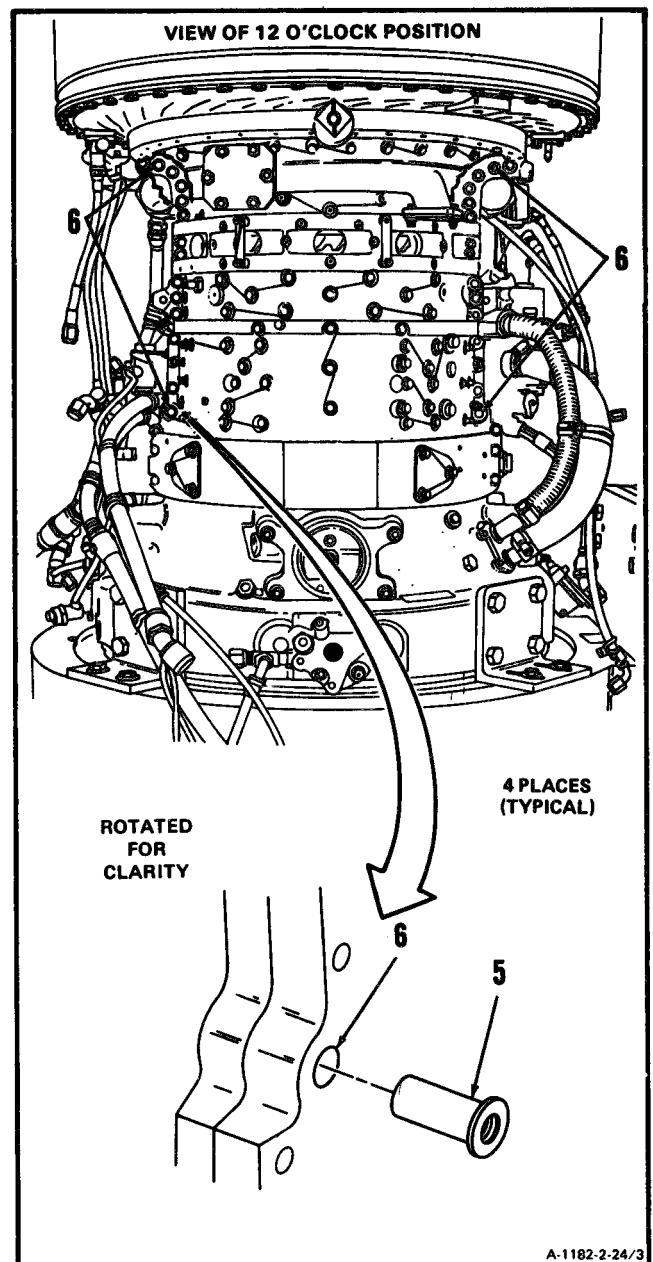

GO TO NEXT PAGE

NOTE

Procedure for installing nuts, bolts, and washers in four dowel pins is the same. Procedure for only one is shown.

3. Install bolt (7), washer (8), and nut (9) in dowel pin (5).

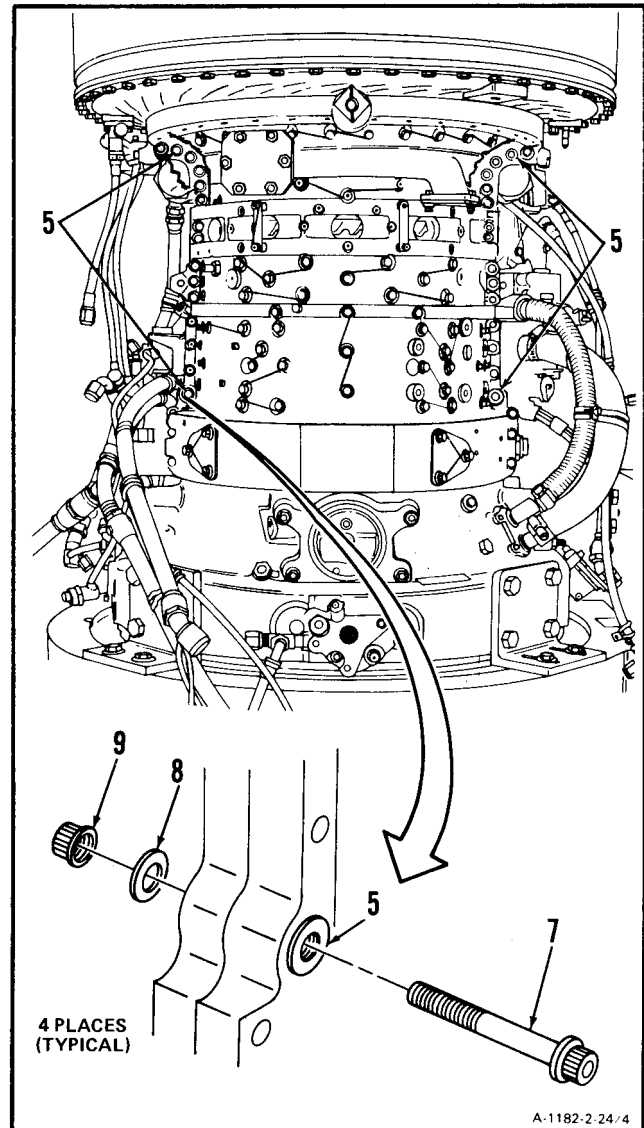

GO TO NEXT PAGE

4. **Install** 42 washers (10), **21 bolts (11)**, and nuts (12) into holes (13).

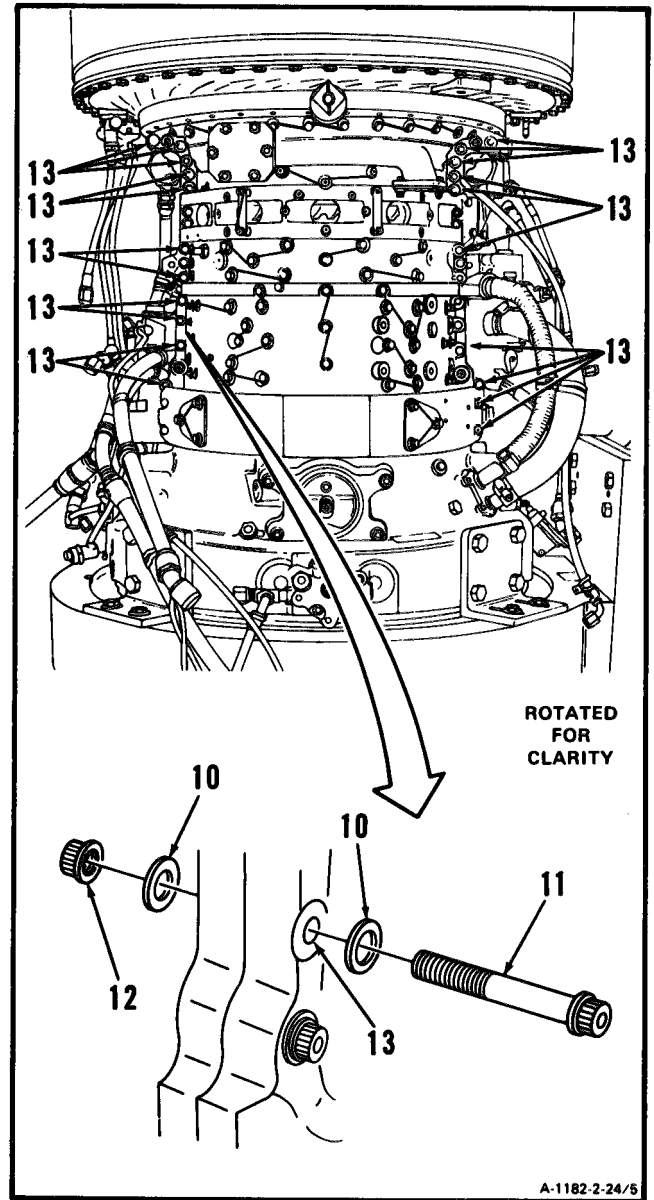

GO TO NEXT PAGE

5. Install six washers (14), three bolts with 1/4 inch heads (15), and nuts (16) into holes (17).

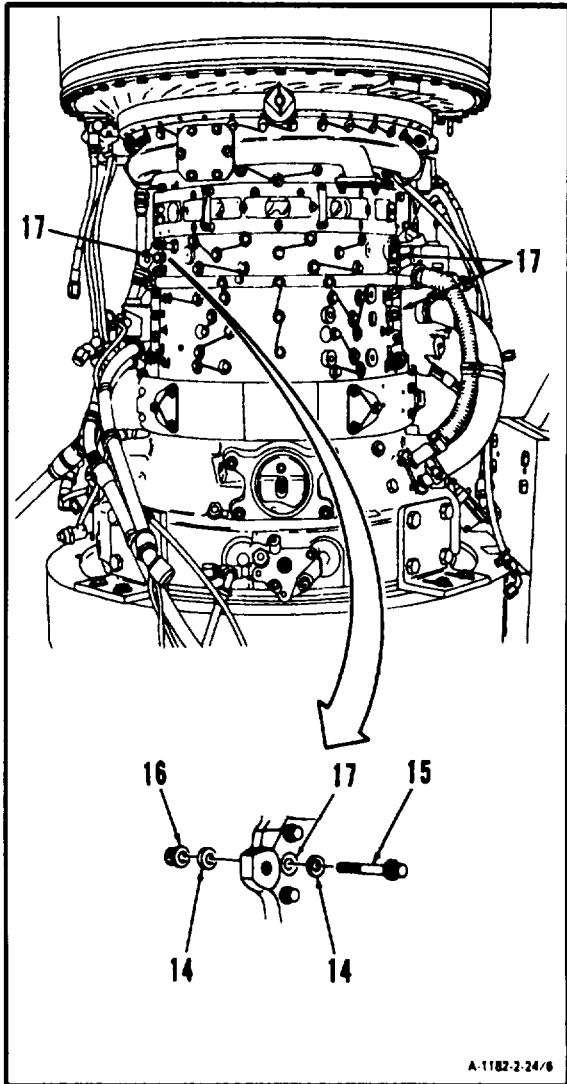

GO TO NEXT PAGE

6. **Install** four washers (18), **two bolts (19)**, and two nuts (20).

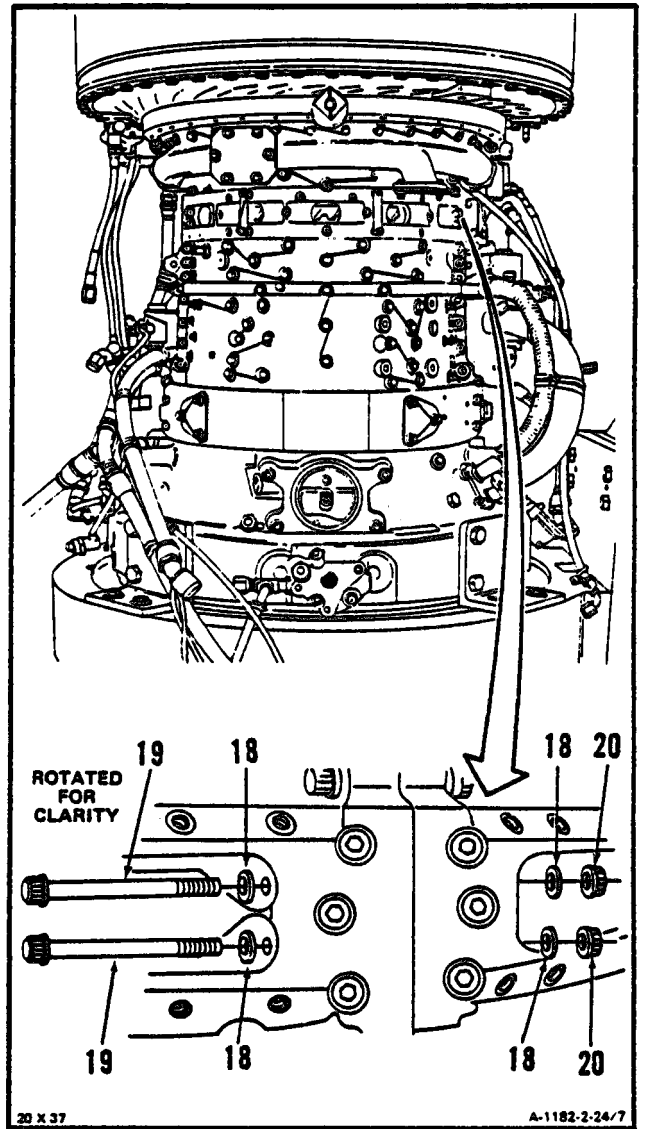

GO TO NEXT PAGE

2-24 INSTALL UPPER COMPRESSOR HOUSING (Continued)

2-24

- 7. Install four washers (21), two bolts (22), and two nuts (23).

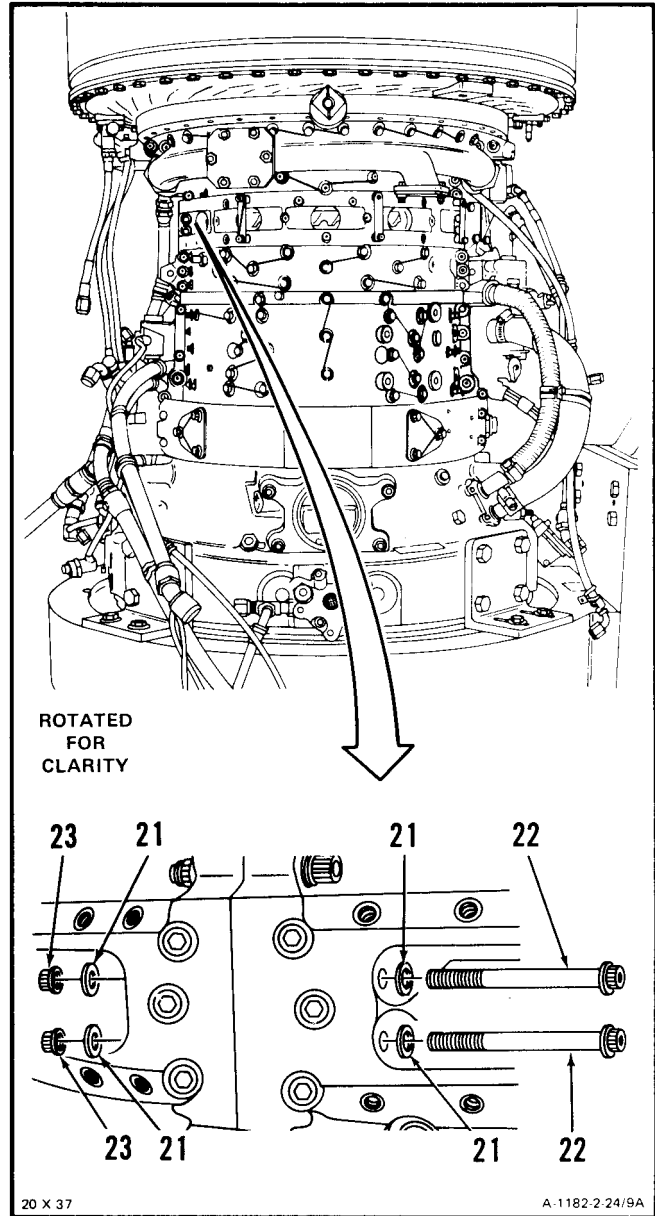

GO TO NEXT PAGE

2-24 INSTALL UPPER COMPRESSOR HOUSING (Continued)

8. Install bleed band retainer (24) and bolt (25).

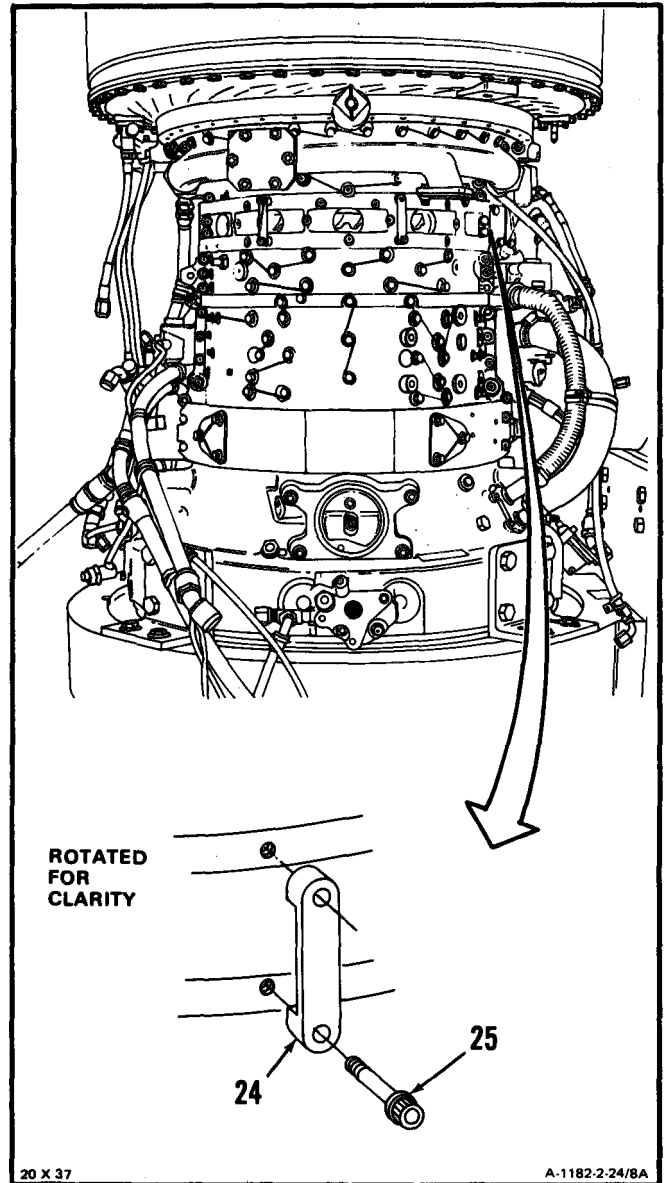

GO TO NEXT PAGE

2-24 INSTALL UPPER COMPRESSOR HOUSING (Continued)

9. Install two spacers (26), bracket (27), two bolts (28), washers (29), nuts (30), bolt (31), and washer (32).
10. Lockwire bolt (31). Use lockwire (E29).

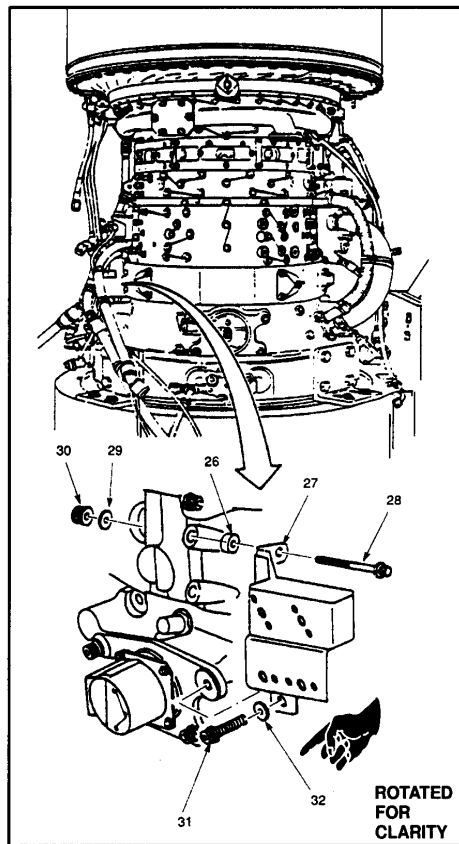

GO TO NEXT PAGE

2-24 INSTALL UPPER COMPRESSOR HOUSING (Continued)

2-24

11. **Connect nut (32) to connector (33). Torque nuts (32 and 34) to 90 inch-pounds.** Use crow-foot attachment (T66) and 1-5/8 inch open-end wrench.
12. Lockwire nuts (32 and 34). Use lockwire (E29).

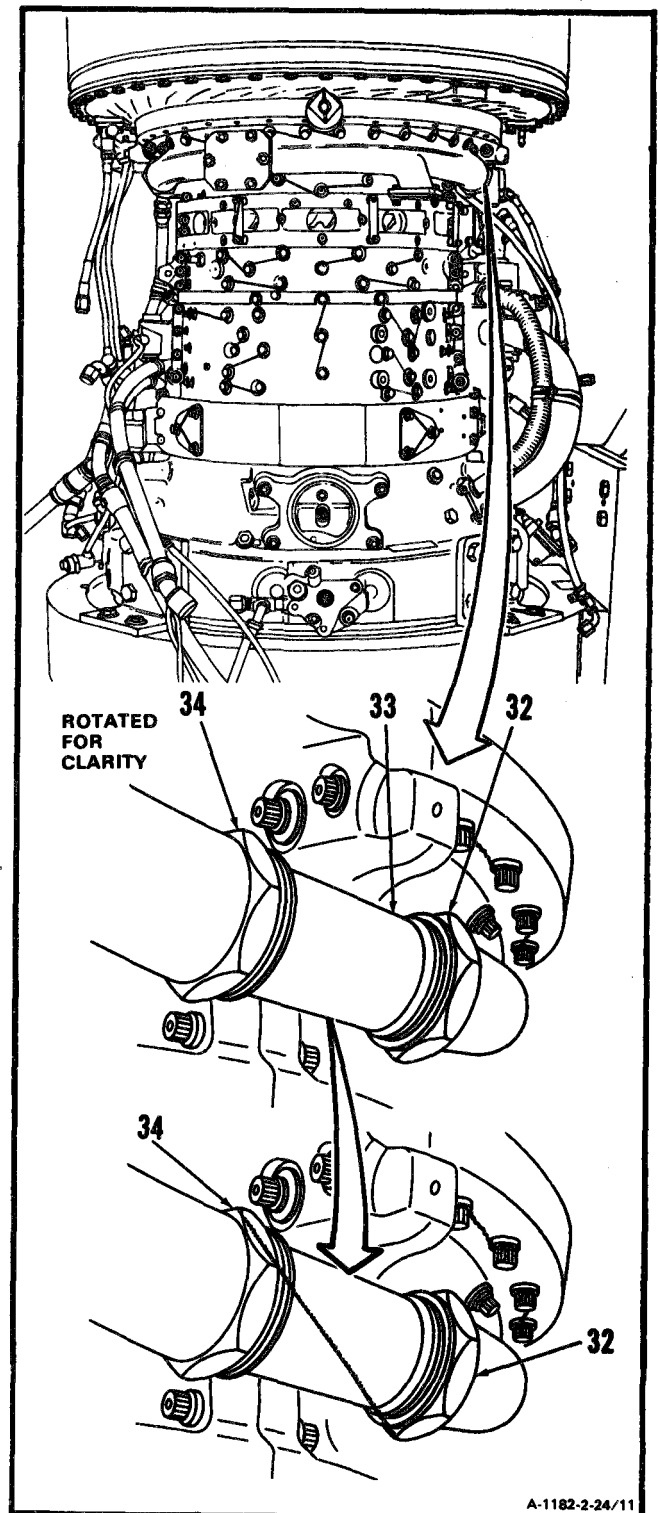

GO TO NEXT PAGE

13. **Connect nut (35) to connector (36). Torque nuts (35 and 37) to 90 inch-pounds.** Use crow-foot attachment (T66) and 1-5/8 inch open-end wrench.

14. Lockwire nuts (35 and 37). Use lockwire (E29).

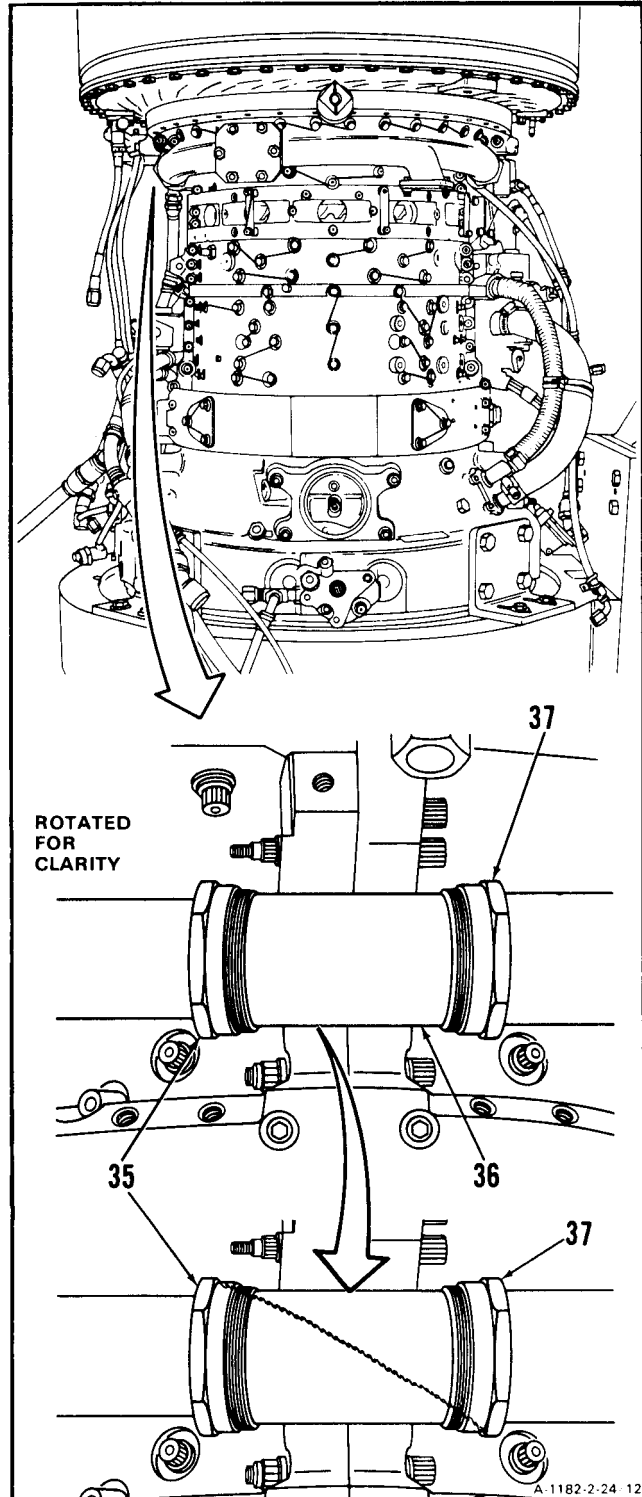

GO TO NEXT PAGE

2-24 INSTALL UPPER COMPRESSOR HOUSING (Continued)**2-24****NOTE**

If compressor housing has **thin walled rear hoist point** do steps 15. and 16. and omit step 16.1, 16.2, 16.3 and 16.4.

If compressor housing has **beefed-up rear hoist point**, omit steps 15. and 16. and do steps 16.1, 16.2, 16.3 and 16.4.

15. **Install 16** washers (38) and **bolts (39)**.

16. Lockwire bolts (39). Use lockwire (E29).

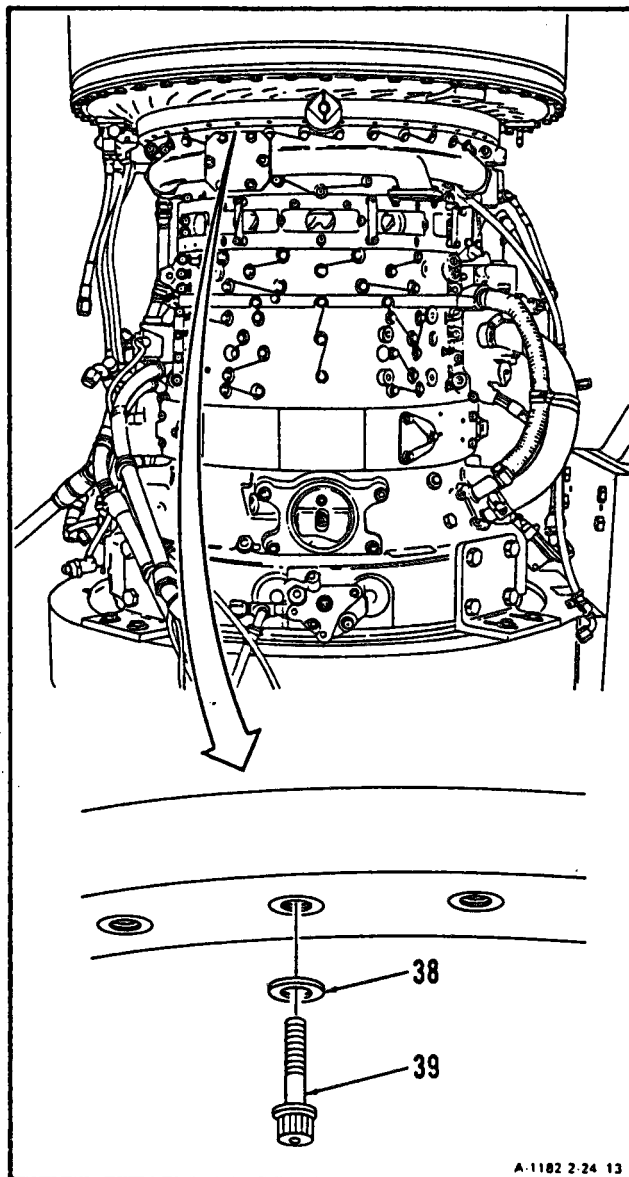

A-1182 2-24 13

GO TO NEXT PAGE

2-24 INSTALL UPPER COMPRESSOR HOUSING (Continued)

- 16.1 **Install** eight washers (39.1) and **bolts (39.2)**.
- 16.2 **Install** six washers (39.1) and **bolts (39.3)**.
- 16.3 **Install** two washers (39.1) and **bolts (39.4)**.
- 16.4 Lockwire bolts (39.2), (39.3) and (39.4). Use lockwire (E29).

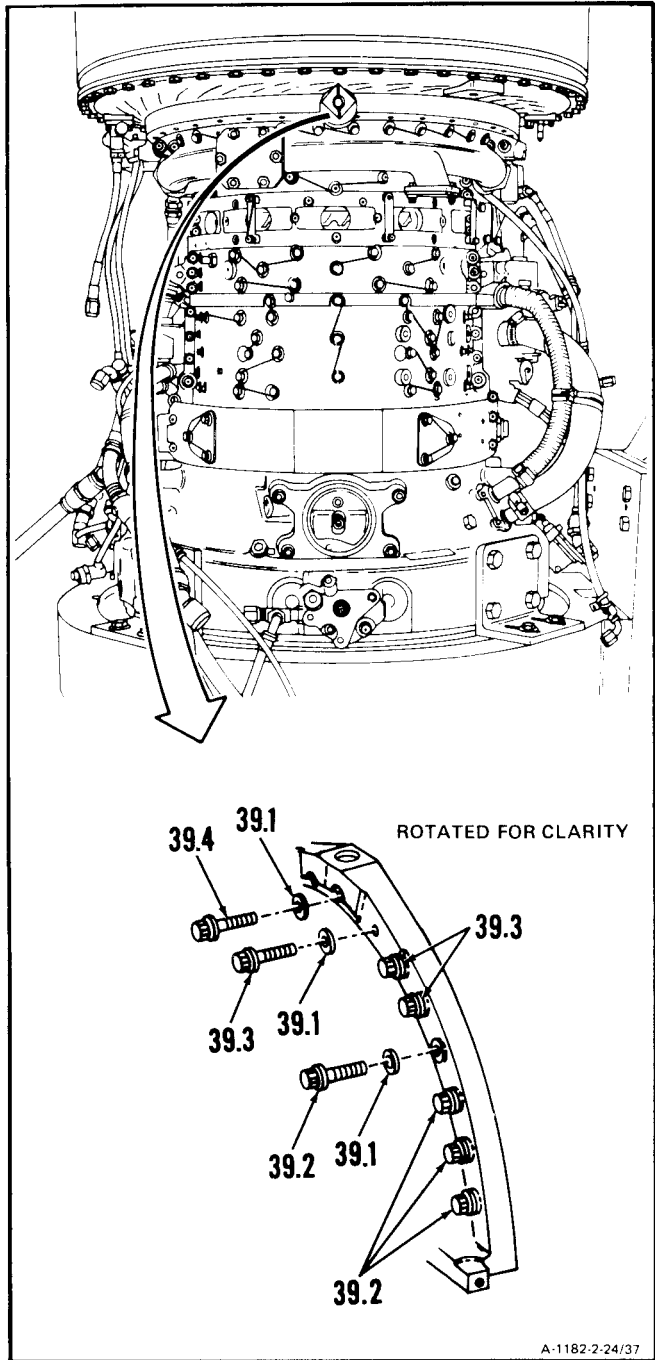

GO TO NEXT PAGE

2-24 INSTALL UPPER COMPRESSOR HOUSING (Continued)

2-24

17. Install two spacers (40), brackets (41 and 42), and bolts (43).

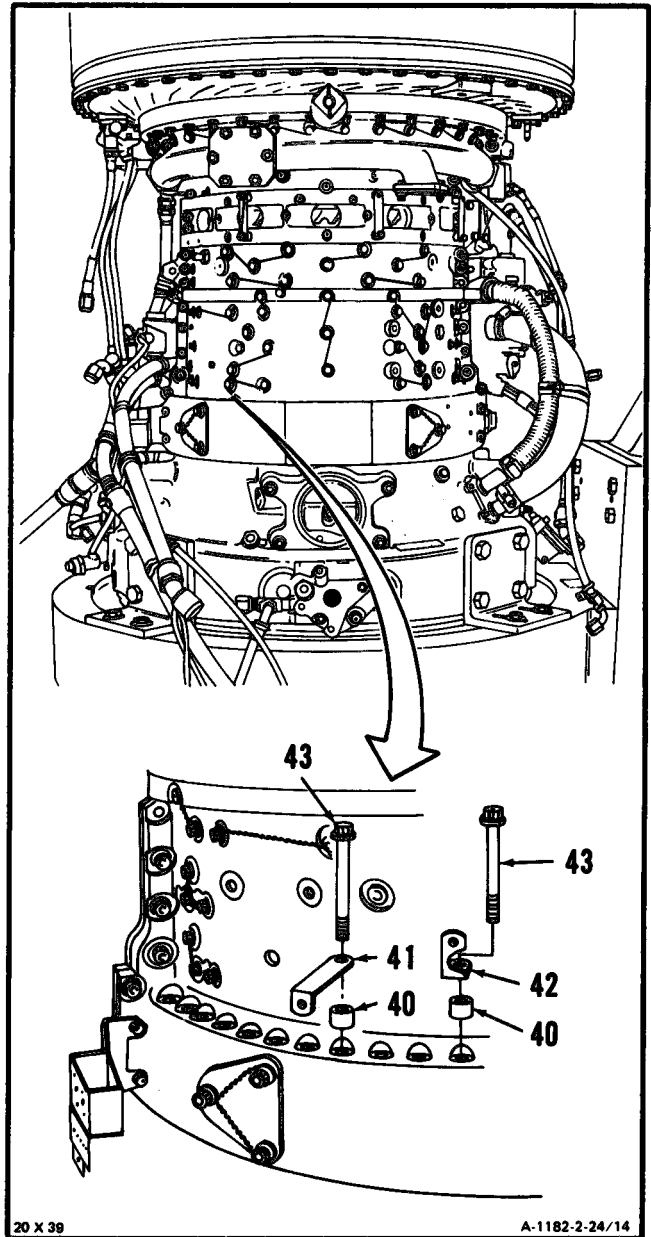

GO TO NEXT PAGE

18. Install **23** washers (44) and **bolts** (45) in all holes except for three locations (46).

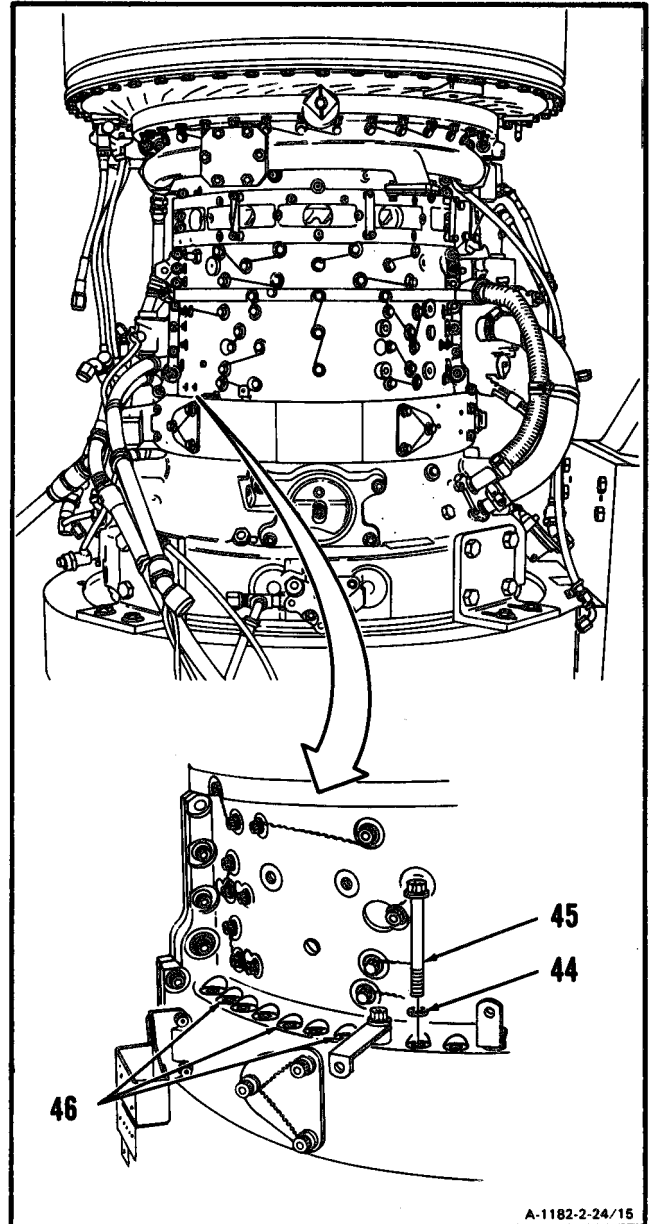

A-1182-2-24/15

GO TO NEXT PAGE

19. **Install** two spacers (52), **bracket (53)**, and bolt (55).

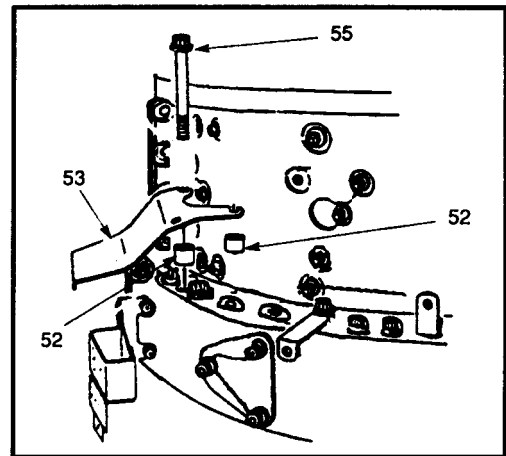

20. **Install** spacer (47), **bracket (49)**, and bolts (55). Lockwire bolts (43), (45), and (55). Use lockwire (E29).

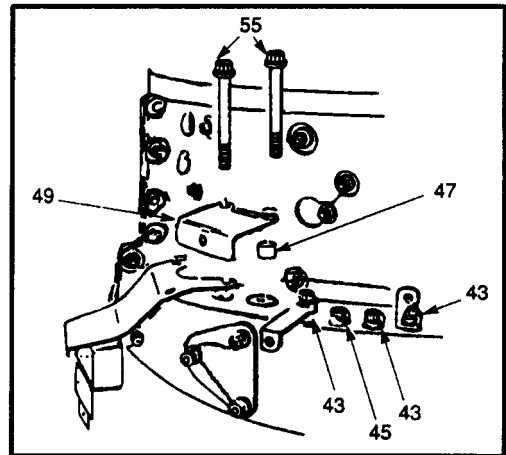

21. **Install** two spacers (56), **bracket (57)**, two washers (58), and bolts (59). **Torque bolts (59) to 15 inch-pounds.**

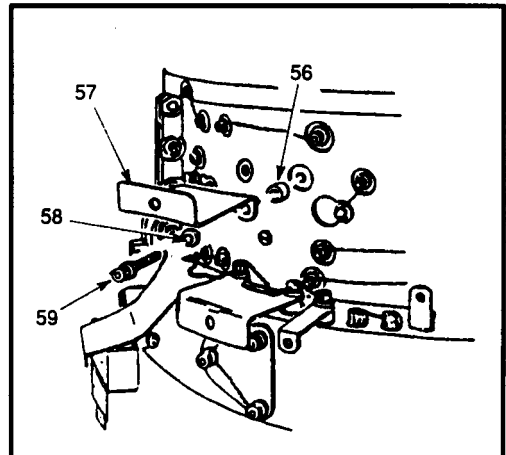

22. Lockwire two bolts (59). Use lockwire (E29).

GO TO NEXT PAGE

2-24 INSTALL UPPER COMPRESSOR HOUSING (Continued)

2-24

23. Position hose assemblies (60, 61 and 62) and electrical cable leads (63 and 64) around upper compressor housing (2).

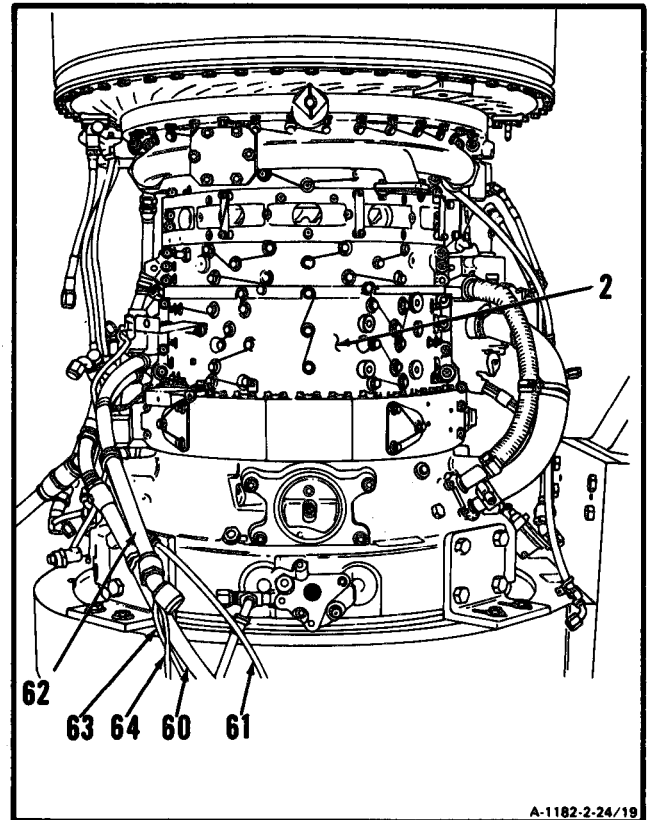

GO TO NEXT PAGE

24. Connect tube and hose assembly (65) to tube assembly (66).

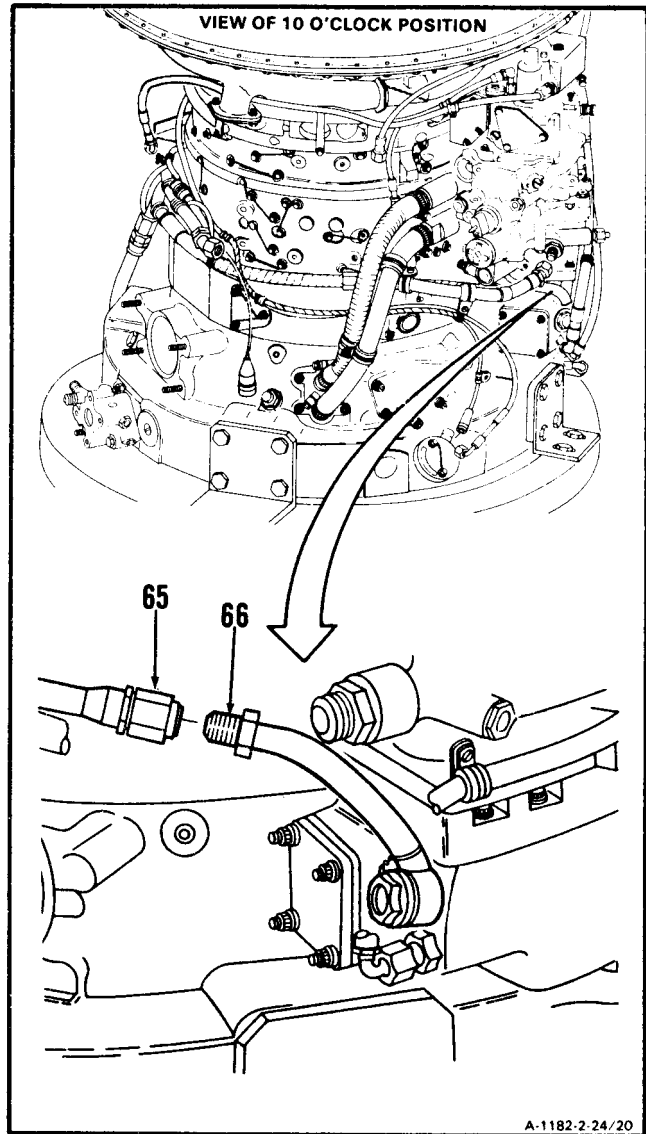

GO TO NEXT PAGE

25. Connect hose assembly (67) to union (68).

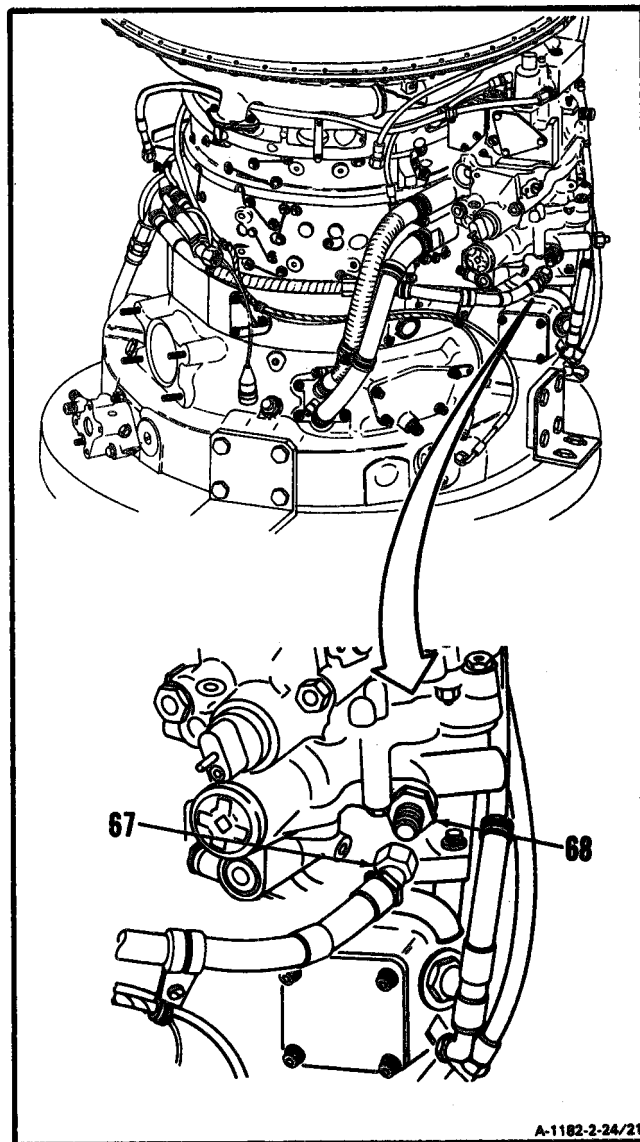

GO TO NEXT PAGE

26. Install clamp (69), screw (70), and nut (71).

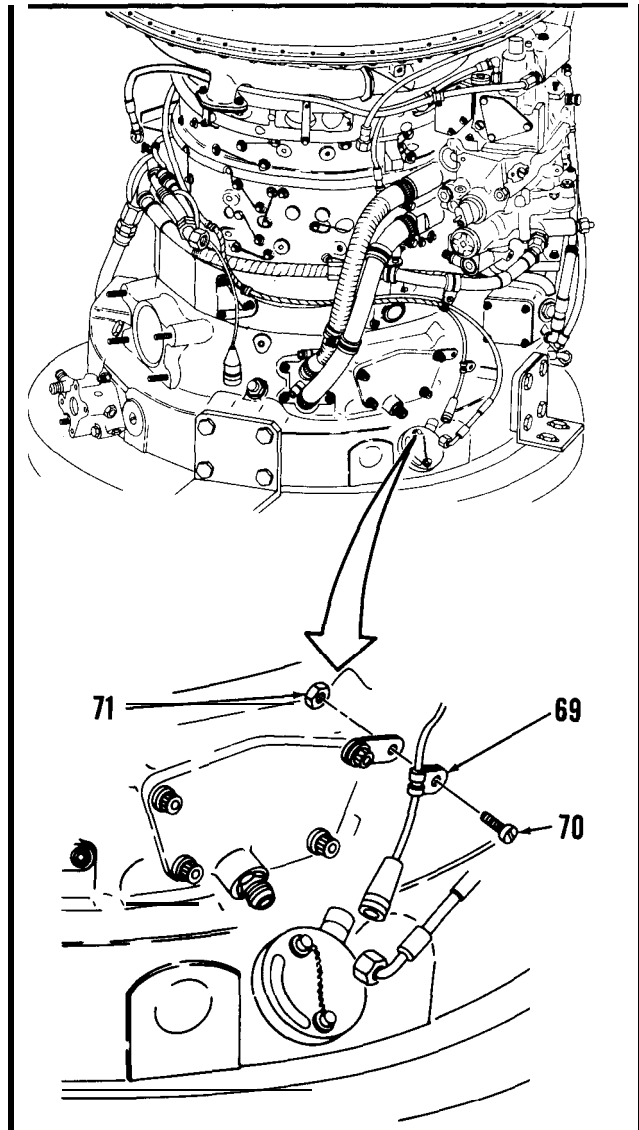

GO TO NEXT PAGE

2-24 INSTALL UPPER COMPRESSOR HOUSING (Continued)

2-24

27. Connect electrical connector (72) to oil level indicator (73).

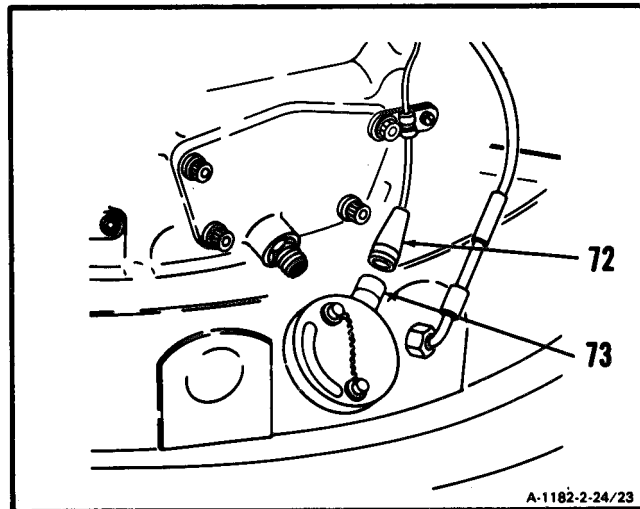

28. Connect hose assembly (74) to nipple (75).

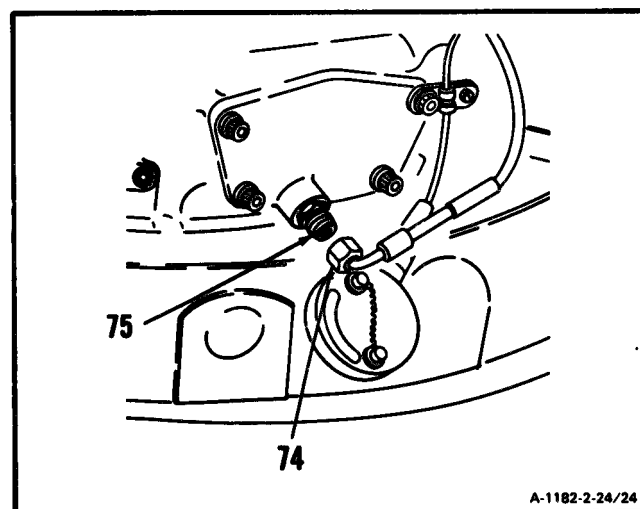

GO TO NEXT PAGE

29. **Install** bracket (76), hose assembly (77), and **solenoid valve (78)** as an assembly.

30. **Install** two spacers (79), **bolts (80)**, washers (81), and nuts (82).

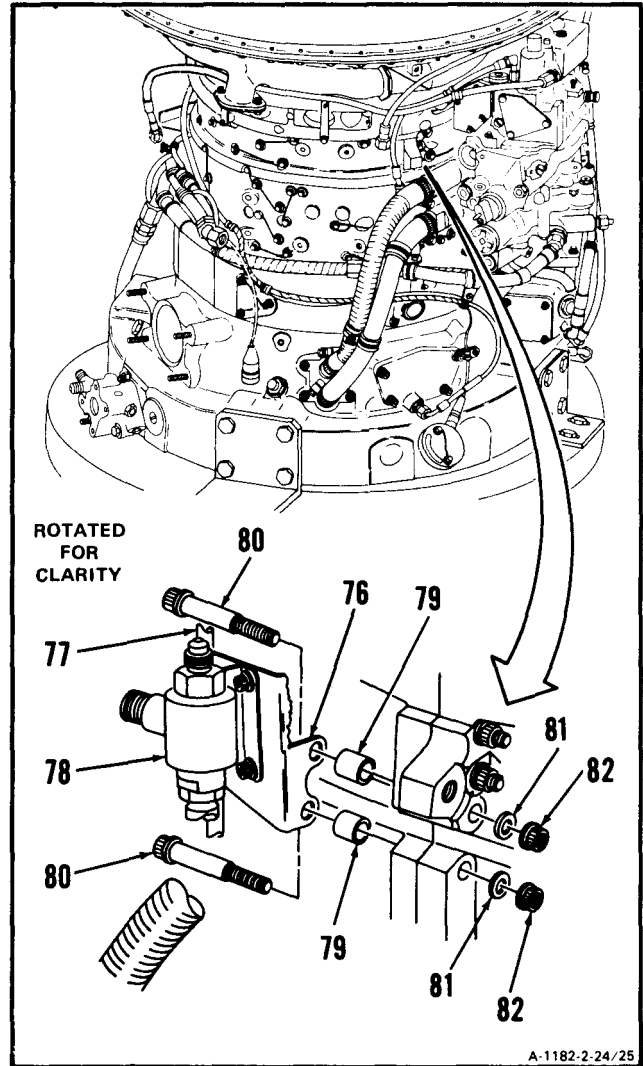

GO TO NEXT PAGE

2-24 INSTALL UPPER COMPRESSOR HOUSING (Continued)

2-24

31. Connect hose assembly (83) to elbow (84).

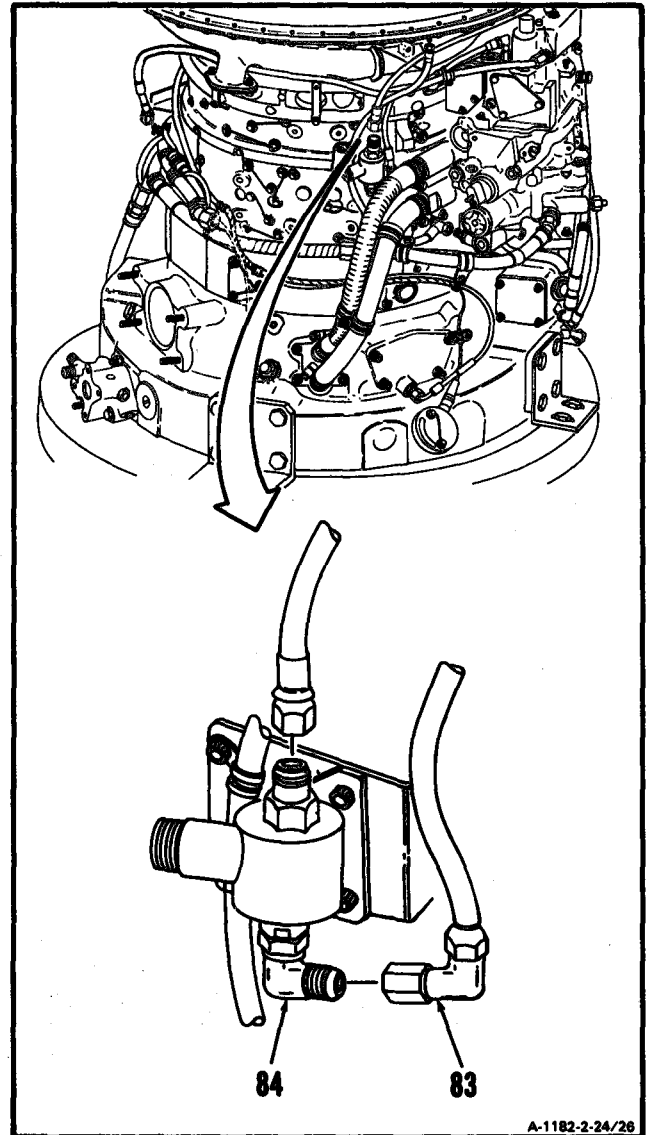

GO TO NEXT PAGE

32. Connect hose assembly (85) to valve (86).

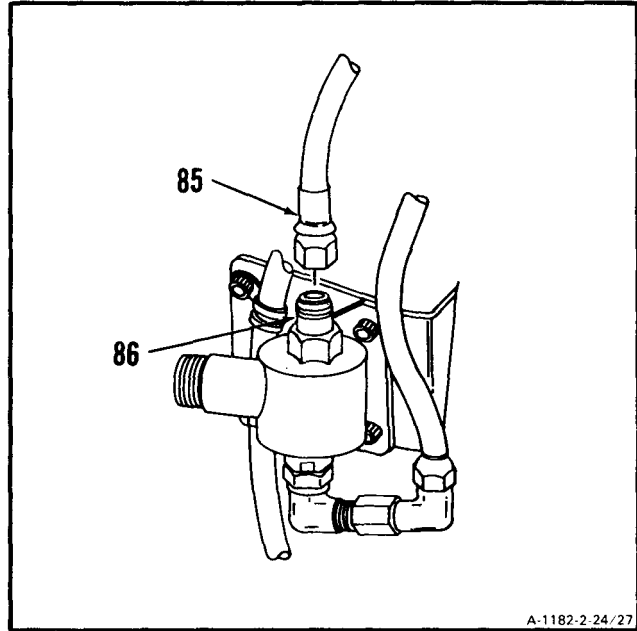

33. Install clamp (87) and screw (88) to compressor housing boss (89). Lockwire screw (88). Use lockwire (E29).

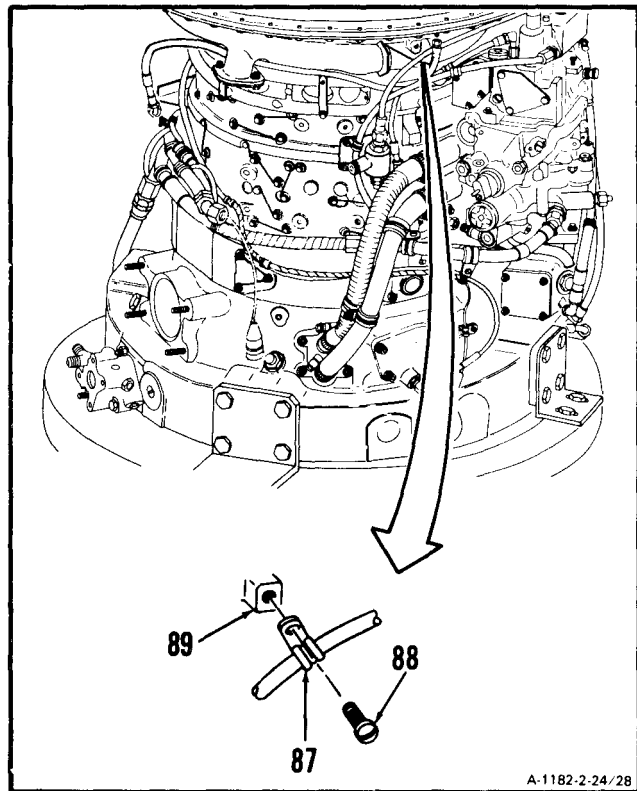

GO TO NEXT PAGE

2-24 INSTALL UPPER COMPRESSOR HOUSING (Continued)

2-24

34. Connect hose assembly (90) to nipple (91).

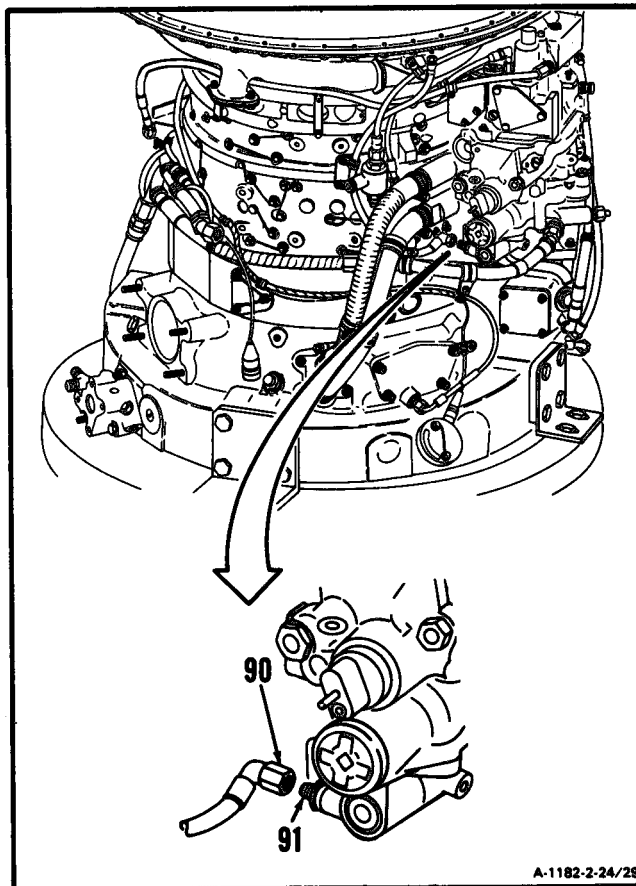

GO TO NEXT PAGE

35. Connect hose assembly (90) to union (92).

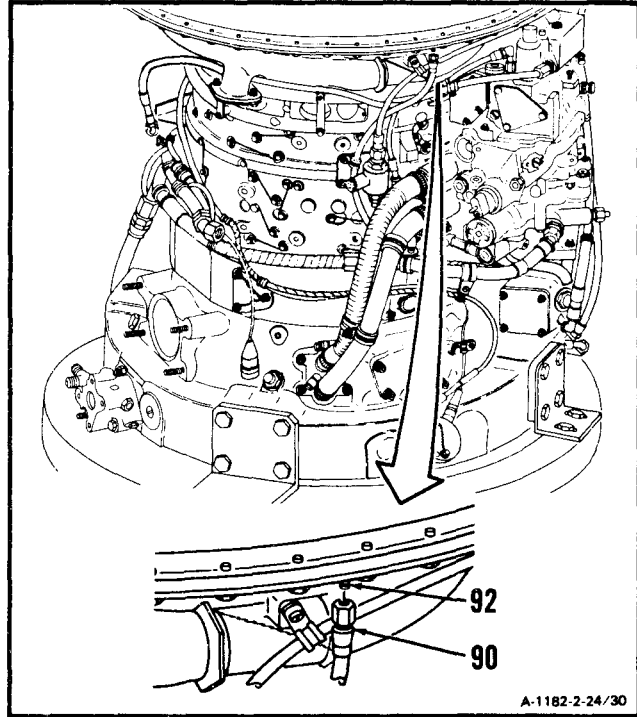

36. Install two clamps (93) and bolts (94).

37. Lockwire bolts (94). Use lockwire (E29).

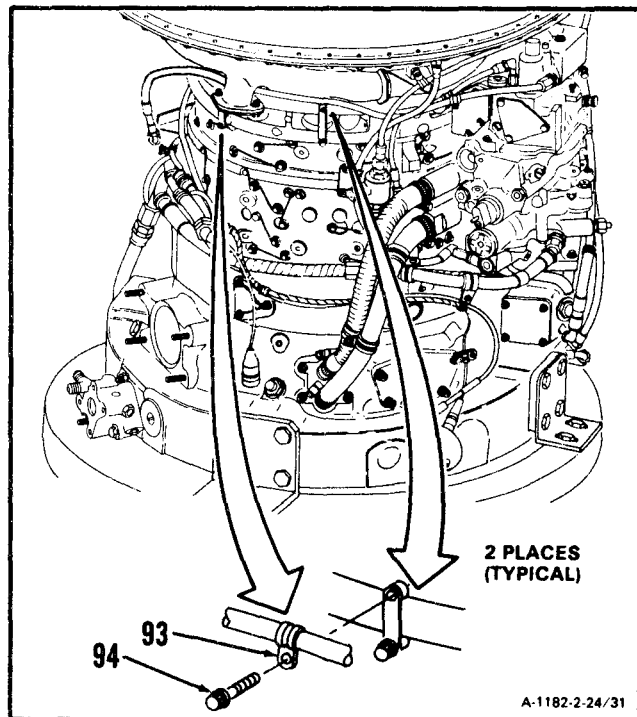

GO TO NEXT PAGE

38. Install clamp (95) and screw (96).

32. Lockwire screw (96). Use lockwire (E29).

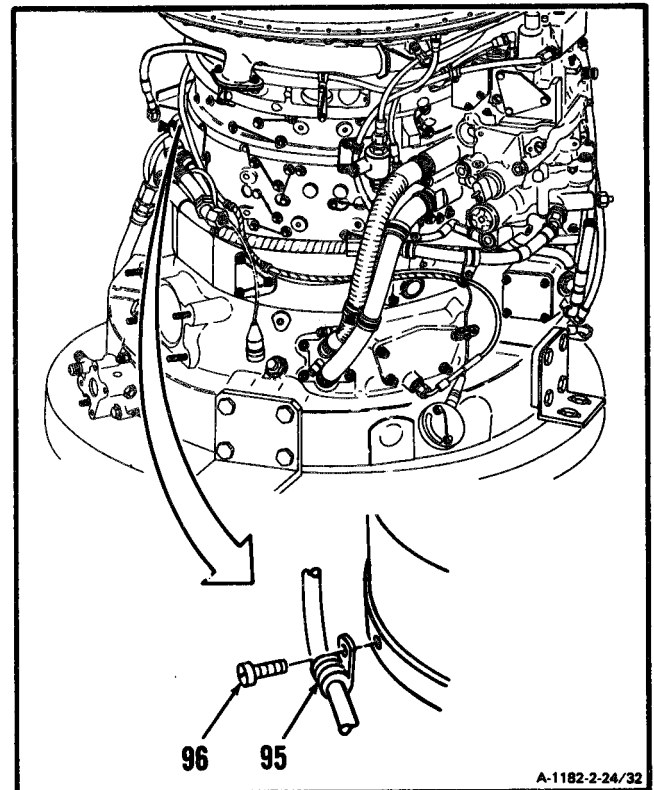

GO TO NEXT PAGE

40. **Install** packing (97), **adapter (98)**, and four bolts (99) to housing (100).
41. Lockwire four bolts (99). Use lockwire (E29).

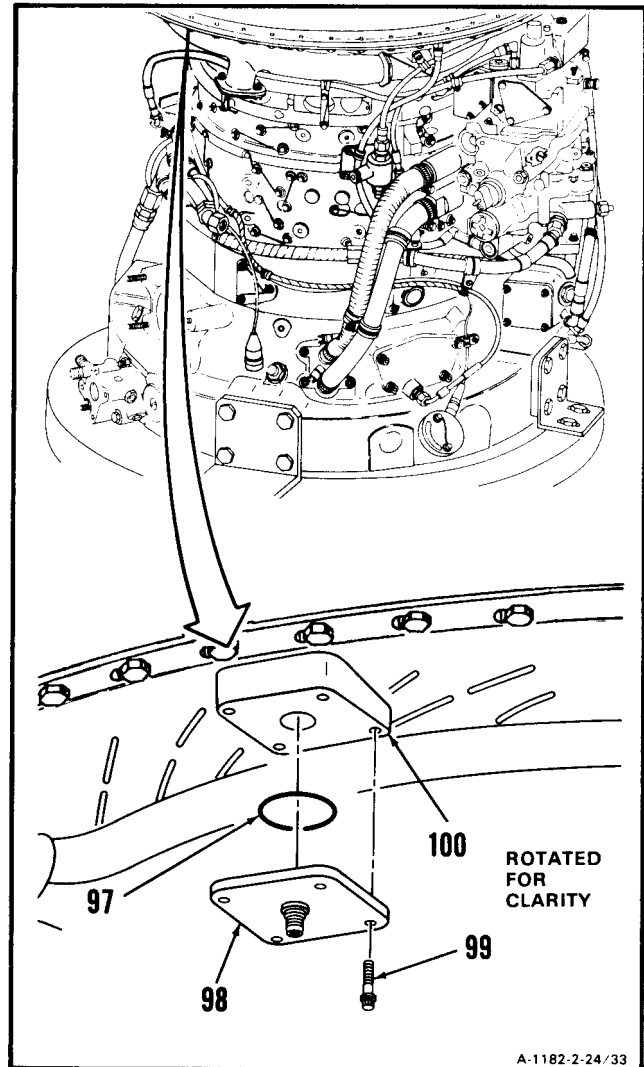

42. **Connect** hose assembly (101) to adapter (98).

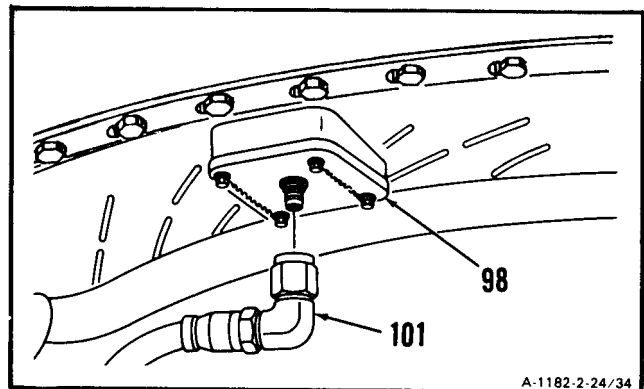

GO TO NEXT PAGE

2-24 INSTALL UPPER COMPRESSOR HOUSING (Continued)

2-24

43. Install two clamps (102), bolt (103) and nut (104).

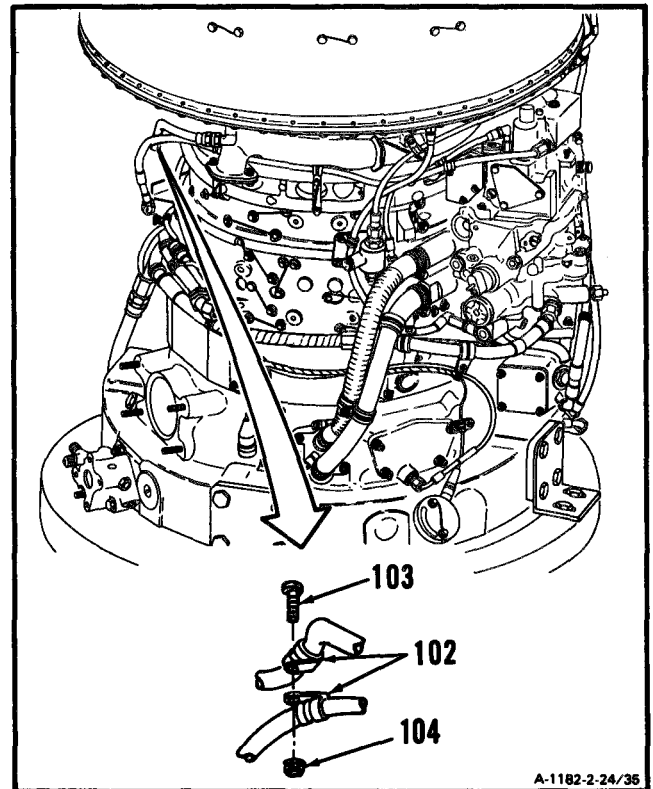
**INSPECT****FOLLOW-ON MAINTENANCE:**

- Install Compressor Bleed Band (Task 2-1 3).
- Install Interstage Air-Bleed Actuator (Task 2-7).
- Install Main Fuel Filter and Bracket (Task 6-35).
- Install Starter Drive Assembly (Task 5-16).
- Install Oil Filler Assembly and Oil Filler Strainer (Task 8-22).
- Install Ignition Exciter (Task 7-15).
- Install In-Line Fuel Filter Assembly (Task 6-41).
- Install Oil Cooler Assembly (Task 8-11).
- Service Engine Oil System (Task 1-74).

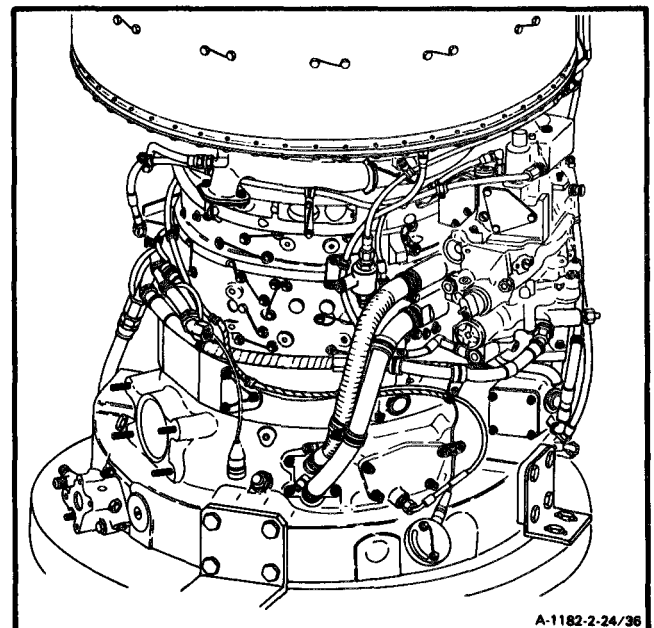
**END OF TASK**

INITIAL SETUP

Applicable Configurations:

All

Tools:

- Powerplant Mechanic's Tool Kit,
NSN 5180-00-323-4944
- Technical Inspection Tool Kit,
NSN 5180-00-323-5114
- Torque Wrench, 30-150 Inch-Pounds
- Open-End Wrench, 1-5/8 Inch
- Crowfoot Attachment (T66)

Materials:

- Lockwire (E29)

Parts:

- Key Washers
- Packings

Personnel Required:

- 68B10** Aircraft Powerplant Repairer (2)
- 68B30** Aircraft Powerplant Inspector

References:

- TM 55-2840-254-23P

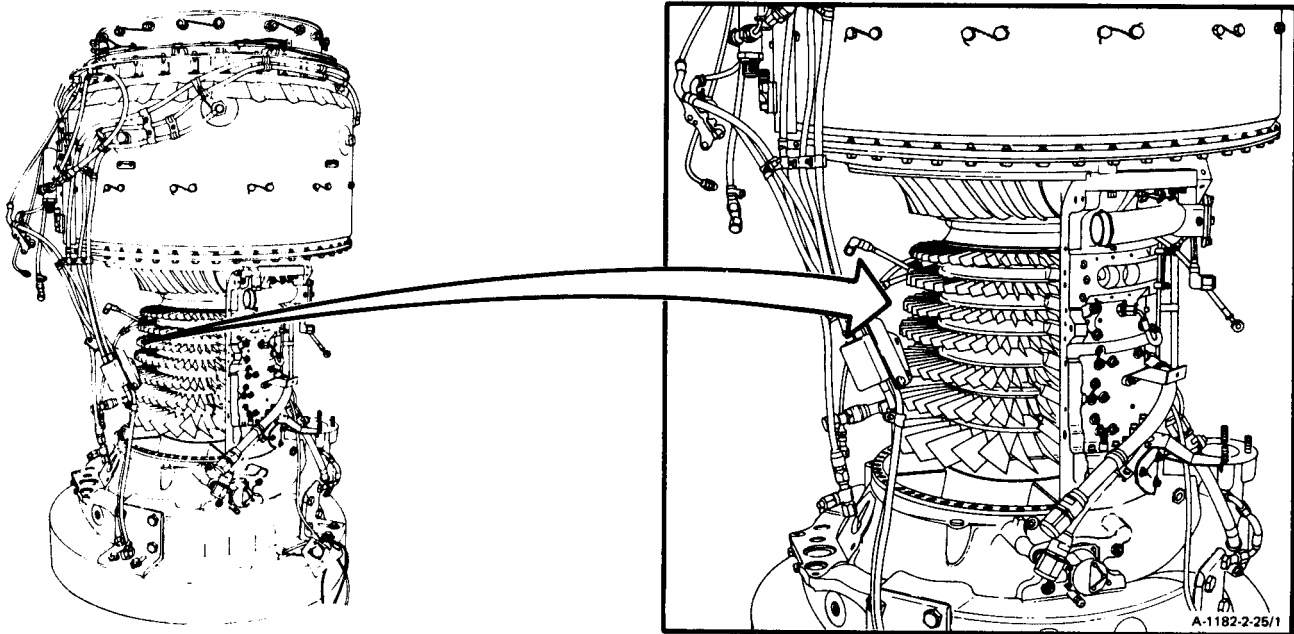

GO TO NEXT PAGE

2-25 INSTALL LOWER COMPRESSOR HOUSING (Continued)

2-25

NOTE

Some engine compressor housings may have provisions for a packing and plug installed at the 9-o'clock position. If required, assure installation.

1. Have helper lift up on combustion section and power turbine (1) and **install lower compressor housing (2)**. Align two connectors (3) with air gallery (4).

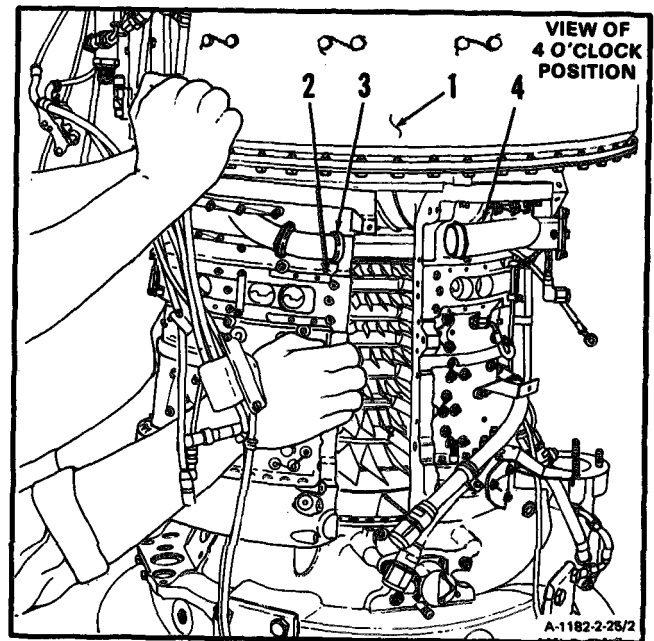
**GO TO NEXT PAGE**

NOTE

Procedure for installing four dowel pins is the same. Procedure for only one is shown.

2. **Align dowel pin (5)** with hole (6) and tap in dowel pin (5). Use soft faced mallet.

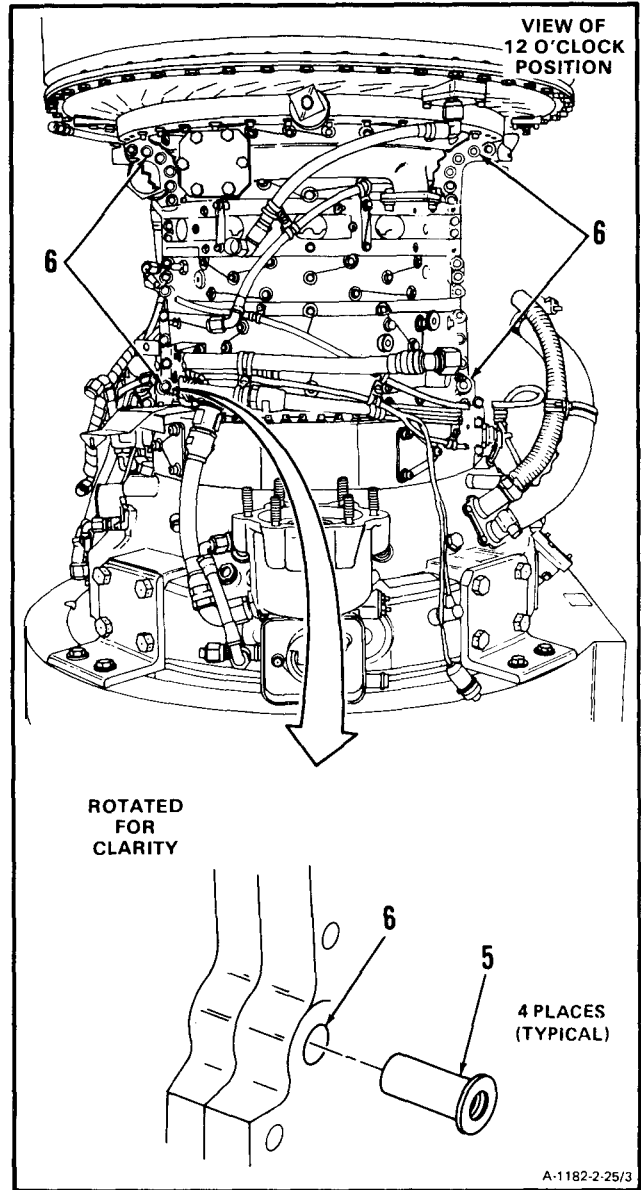

GO TO NEXT PAGE

2-25 INSTALL LOWER COMPRESSOR HOUSING (Continued)

2-25

NOTE

Procedure for installing bolts and washers in four dowel pins is the same. Only one is shown.

3. Install bolt (7), washer (8), and nut (9) in dowel pin (5).

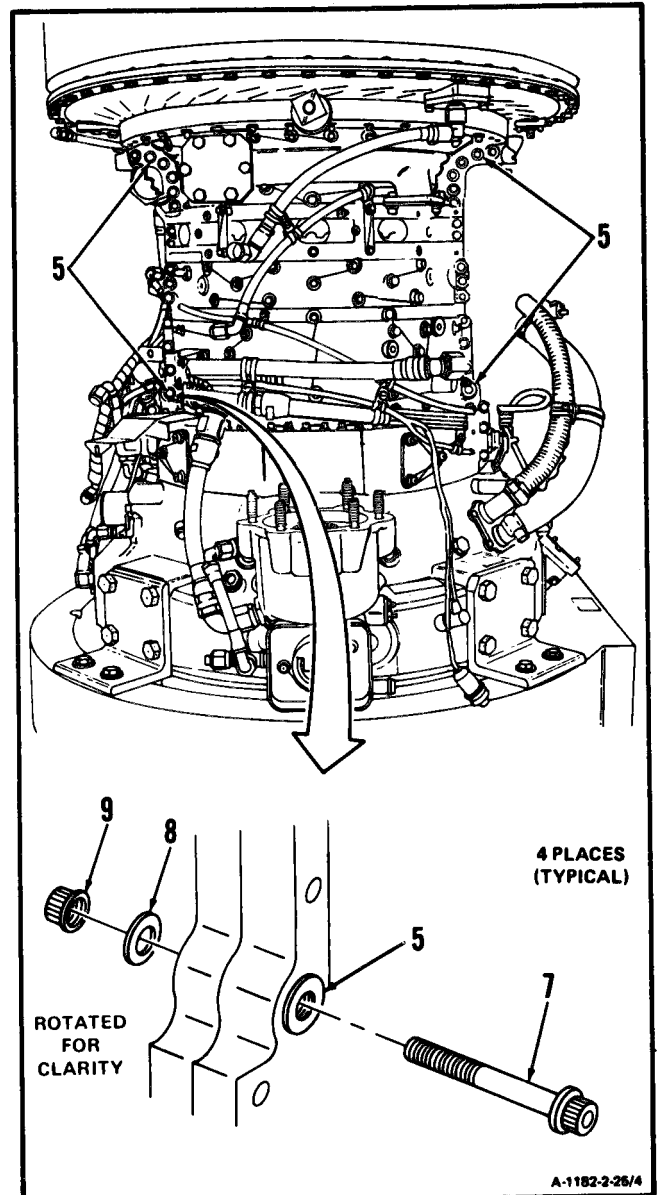
**GO TO NEXT PAGE**

4. **Install** 42 washers (10), **21 bolts** (11), and 21 nuts (12) into holes (13).

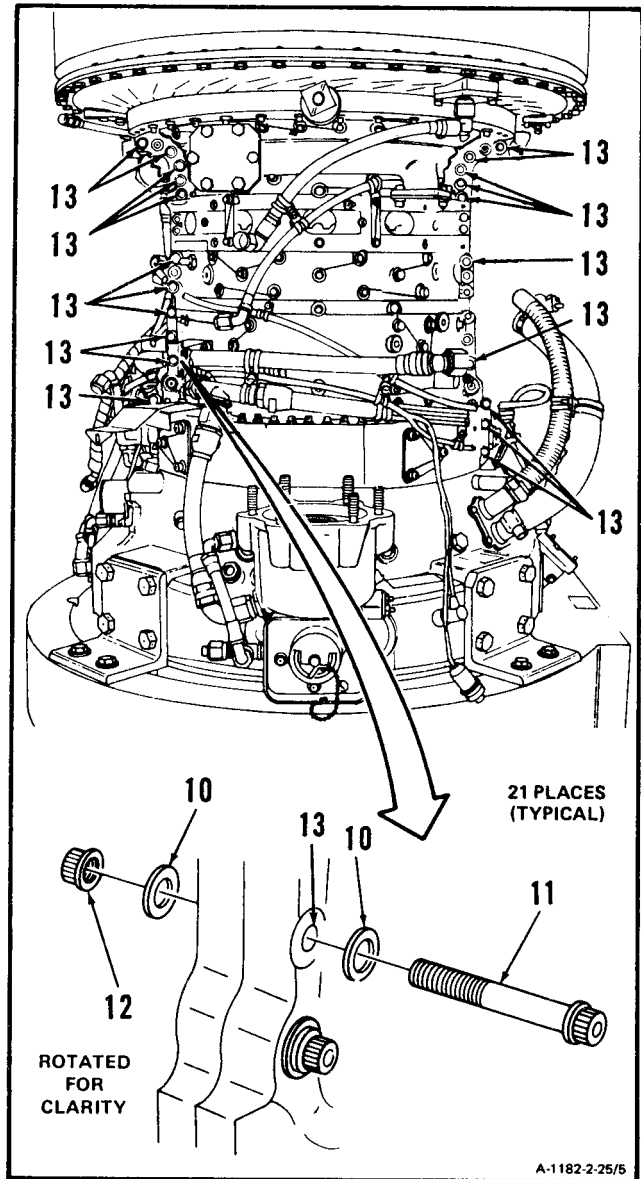

GO TO NEXT PAGE

2-25 INSTALL LOWER COMPRESSOR HOUSING (Continued)

5. Install six washers (14), three bolts (15), and three nuts (16) into holes (17).

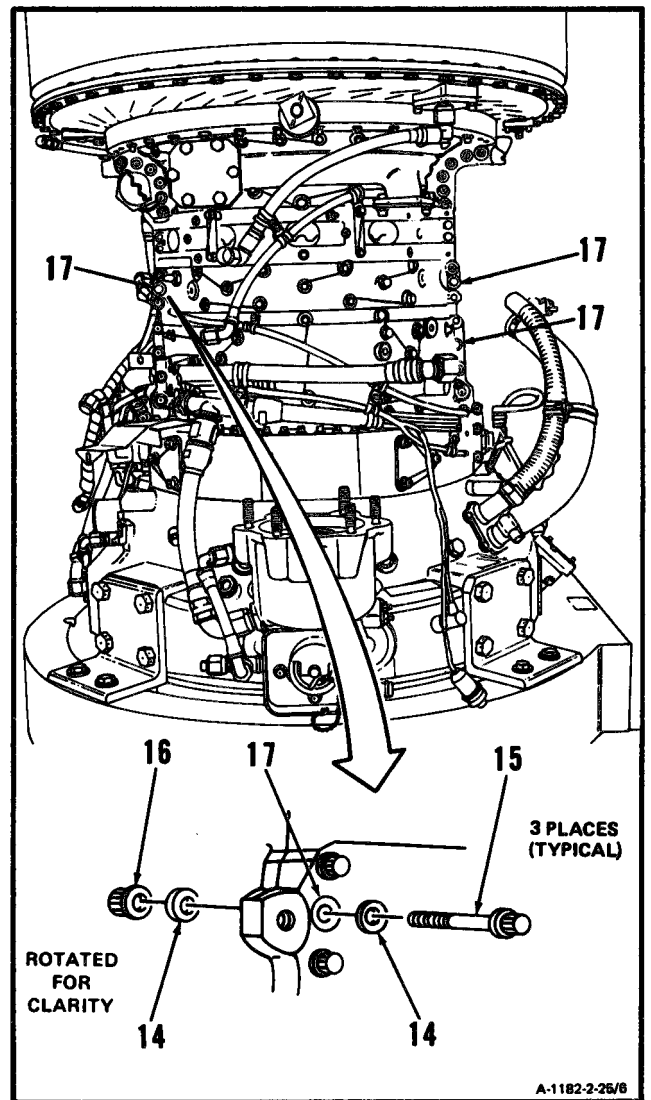

GO TO NEXT PAGE

6. **Install** eight washers (18), **four bolts (19)**, and four nuts (20) into holes (21).

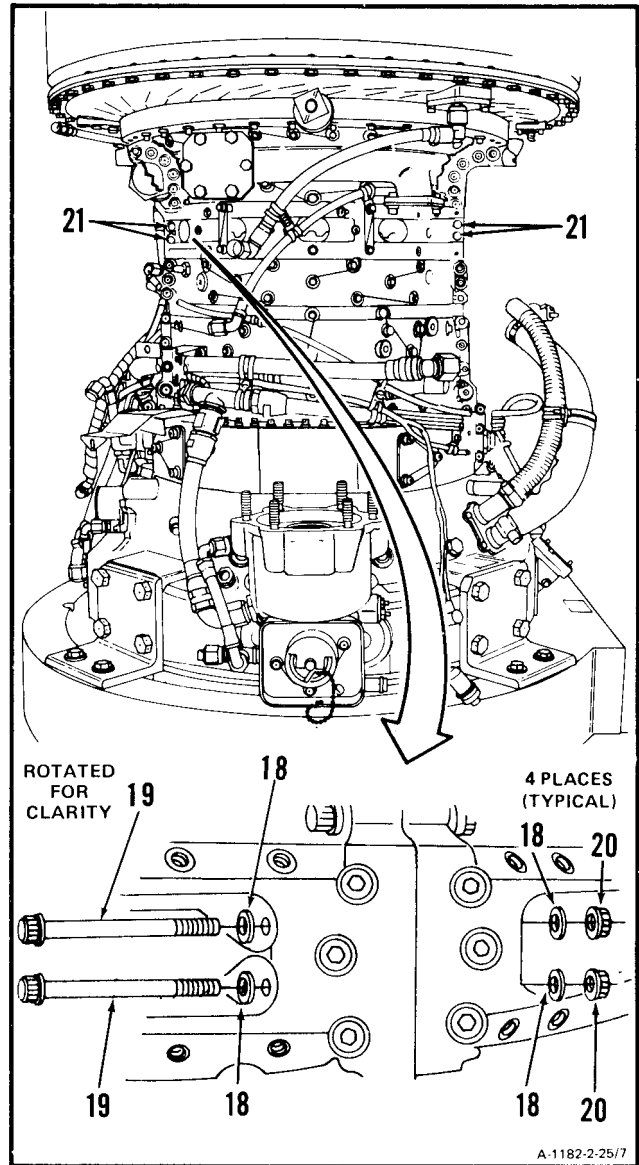

GO TO NEXT PAGE

2-25 INSTALL LOWER COMPRESSOR HOUSING (Continued)

2-25

7. Install bleed band retainer (22), clamp (23) and two bolts (24).

8. Lockwire bolts (24). Use lockwire (E29).

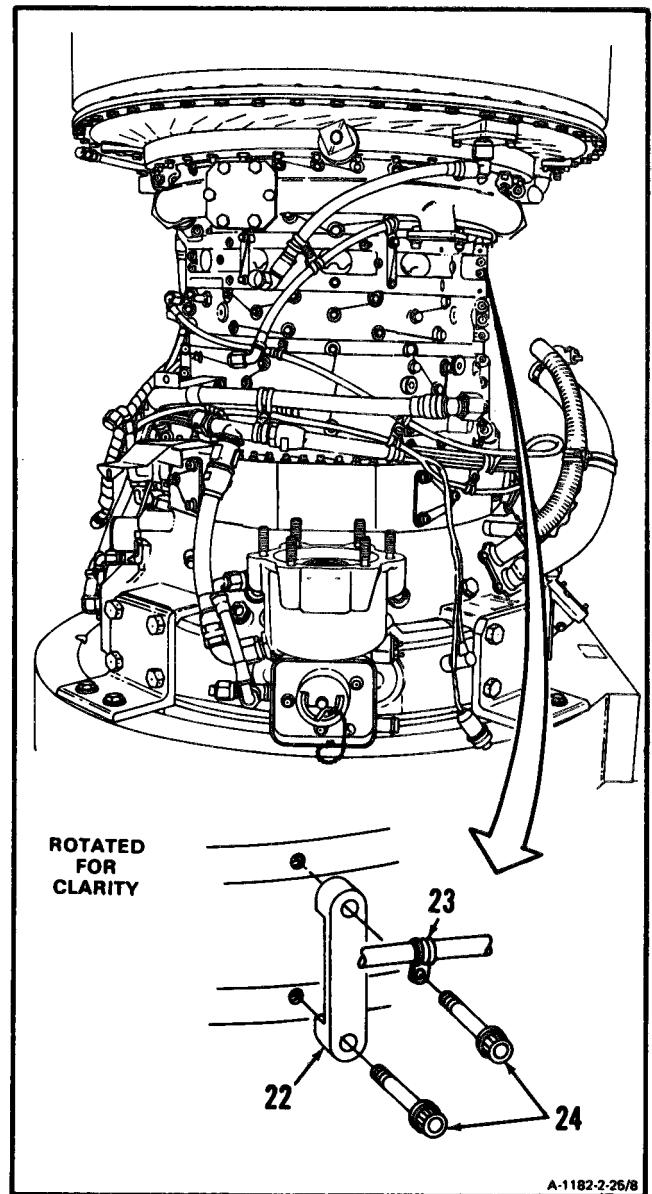

GO TO NEXT PAGE

9. Install 27 washers (25) and bolts (26).

10. Lockwire bolts (26). Use lockwire (E29).

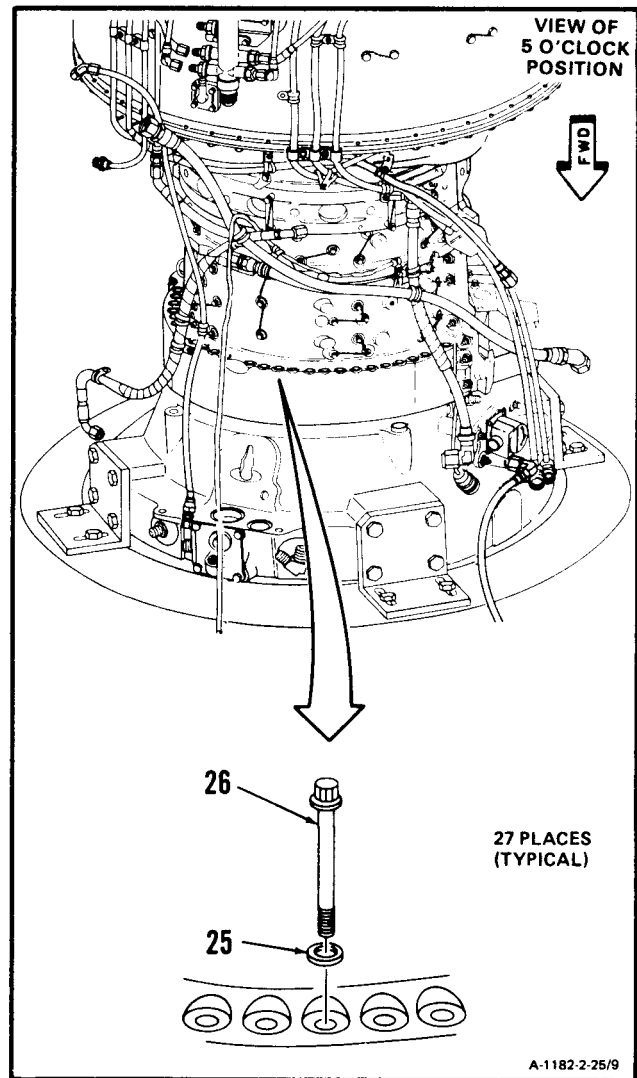

GO TO NEXT PAGE

2-25 INSTALL LOWER COMPRESSOR HOUSING (Continued)

2-25

NOTE

If compressor housing is thin walled at 6 o'clock position do steps 11., 12., 13., 14., and 15.

If compressor housing is beefed-up at 6 o'clock position omit steps 11., 12., 13., 14., and 15.; and do steps 15.1, 15.2, 15.3, 15.4, 15.5, 15.6, 15.7, and 15.8.

11. **Install brackets (27 and 28)**, five washers (29), three bolts (30) and two bolts (30.1).

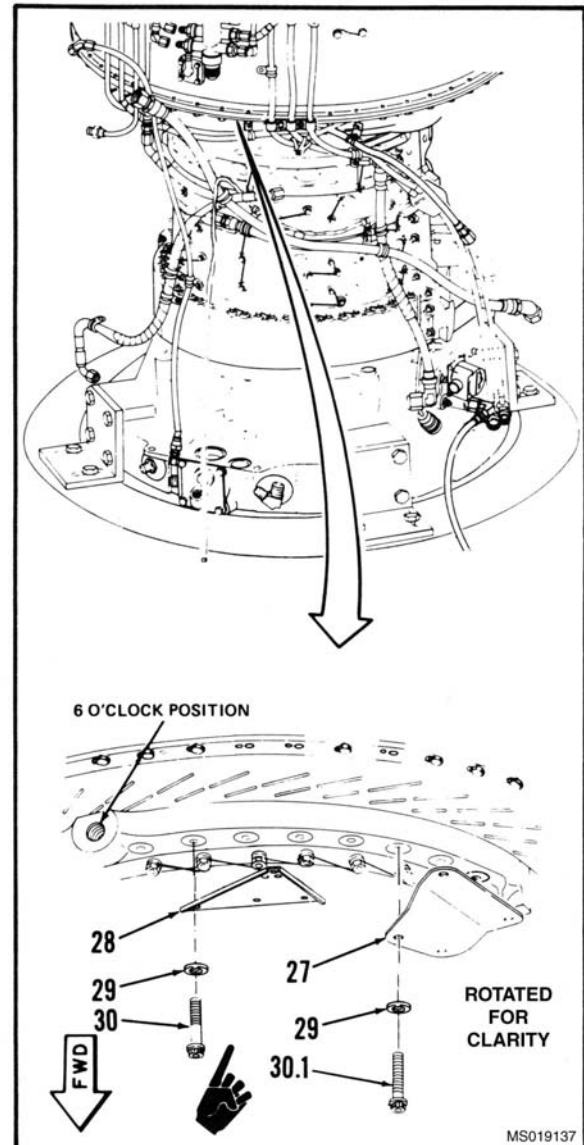

GO TO NEXT PAGE

11. Install bracket (31), spacer (29), and bolt (30).
12. Install bracket (32), spacer (29) and bolt (30).

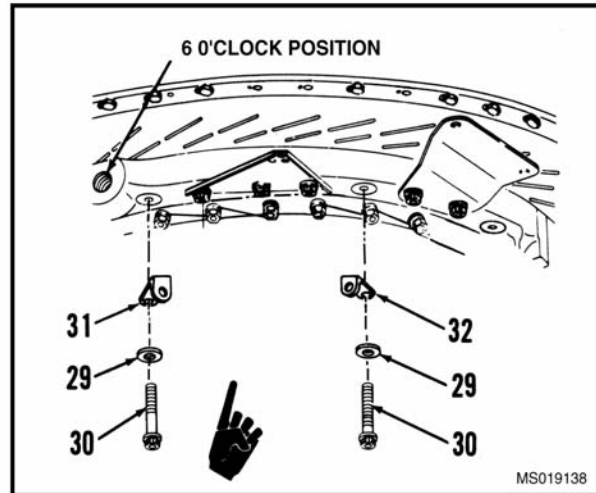

GO TO NEXT PAGE

2-25 INSTALL LOWER COMPRESSOR HOUSING (Continued)

2-25

14. Install nine remaining washers (29) and bolts (30).
15. Lockwire 16 bolts (30). Use lockwire (E29).

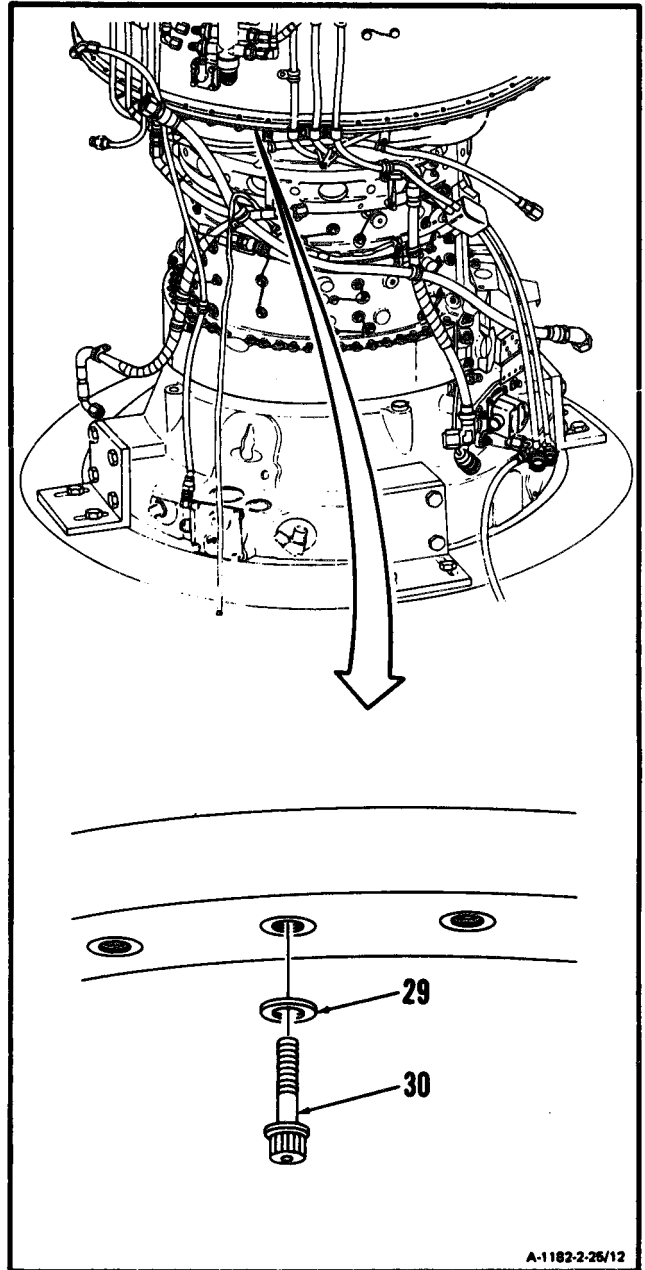

GO TO NEXT PAGE

- 15.1 **Install bracket (32.1)**, two washers (32.2), and two bolts (32.3).
- 15.2 **Install bracket (32.4)**, three washers (32.2), and three bolts (32.5).

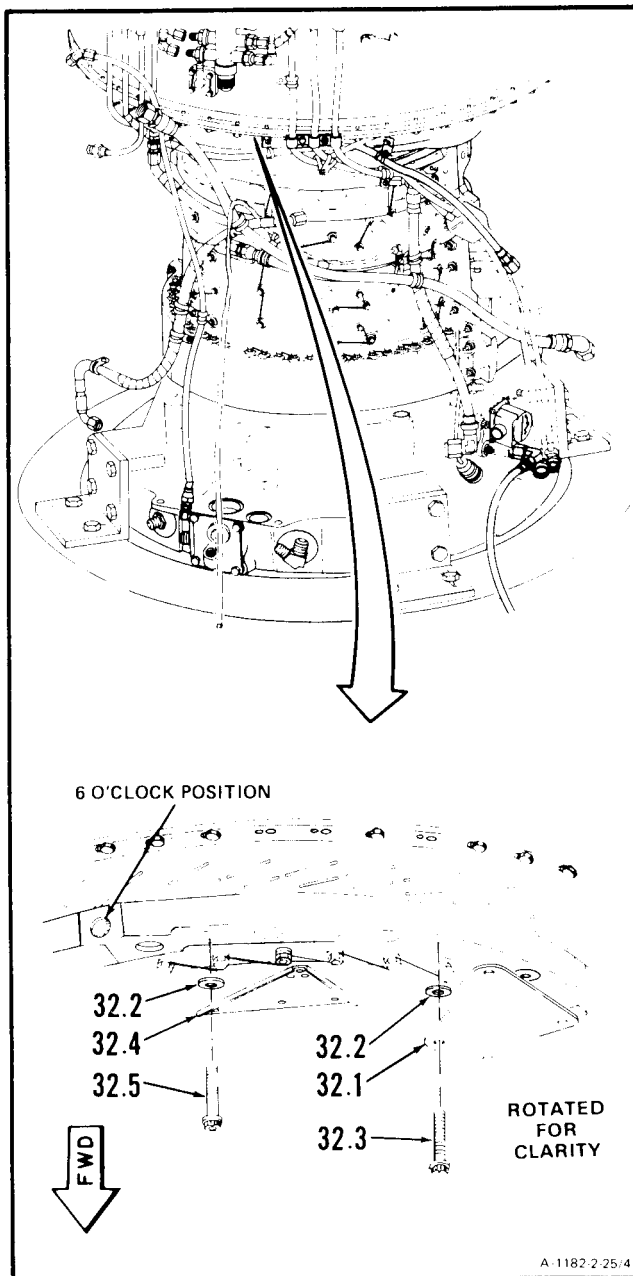

GO TO NEXT PAGE

2-25 INSTALL LOWER COMPRESSOR HOUSING (Continued)

2-25

- 15.3 **Install bracket (32.6)**, spacer (32.7), and bolt (32.8).
- 15.4 **Install bracket (32.9)**, washer (32.2), and bolt (32.3).
- 15.5 Install remaining washer (32.2) and bolt (32.3).

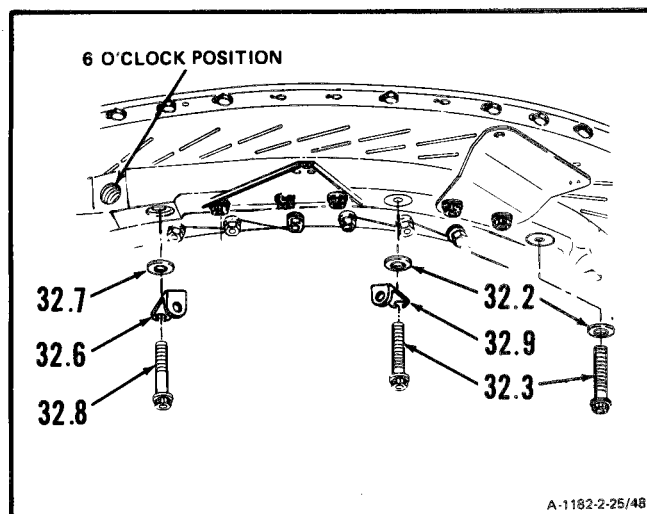
**GO TO NEXT PAGE**

2-25 INSTALL LOWER COMPRESSOR HOUSING (Continued)

- 15.6 Install four washers (32.2) and four bolts (32.3).
- 15.7 Install three washers (32.2) and three bolts (32.5).
- 15.8 Install spacer (32.7) and bolt (32.8).
- 15.9 Lockwire bolts (32.3), (32.5), and (32.8). Use lockwire (E29).

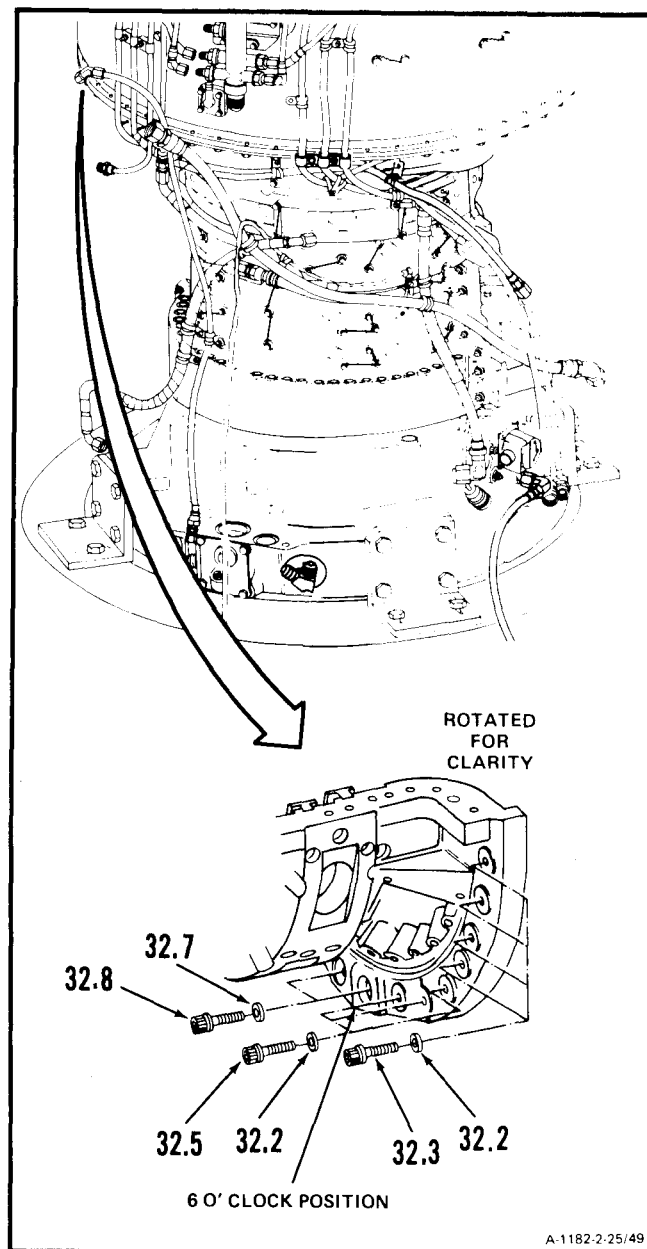

GO TO NEXT PAGE

2-25 INSTALL LOWER COMPRESSOR HOUSING (Continued)

2-25

16. Install four washers (33) and bolts (34) into upper compressor housing bolt holes (35).
17. Lockwire four bolts (34). Use lockwire (E29).

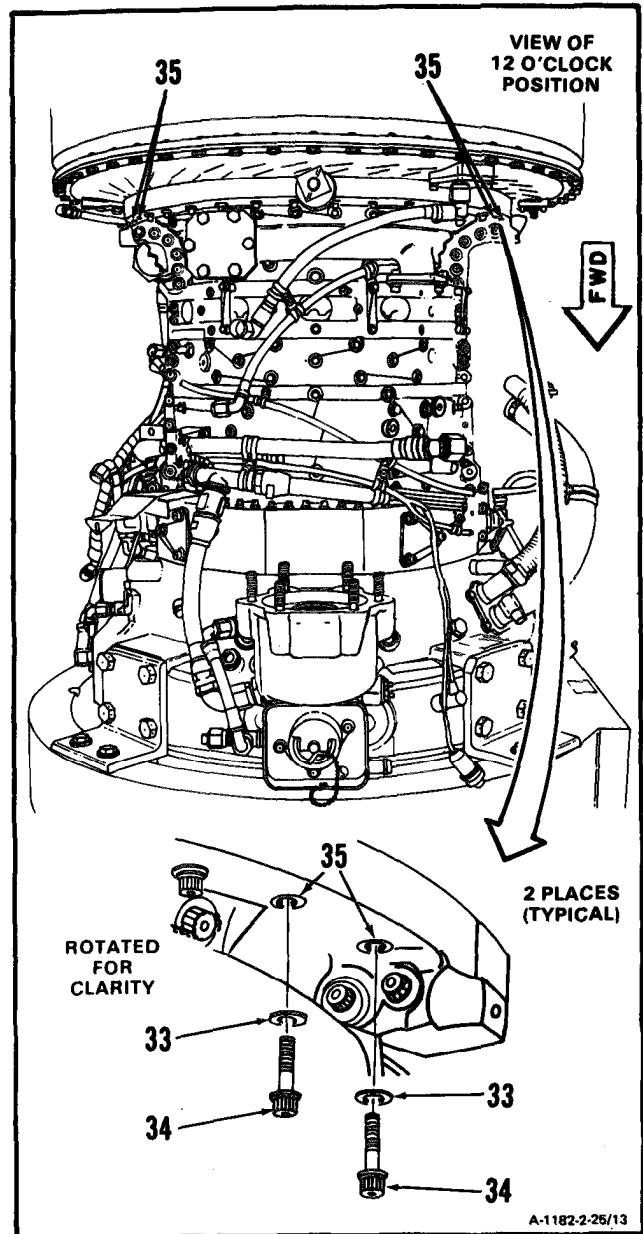

GO TO NEXT PAGE

18. **Connect nut (36) to connector (37).** Hand tighten nut (36). Using crowfoot attachment (T66) and 1-5/8 inch open-end wrench, **torque nuts (36 and 38) to 90 inch-pound.**

19. Lockwire nuts (36 and 38). Use lockwire (E29).

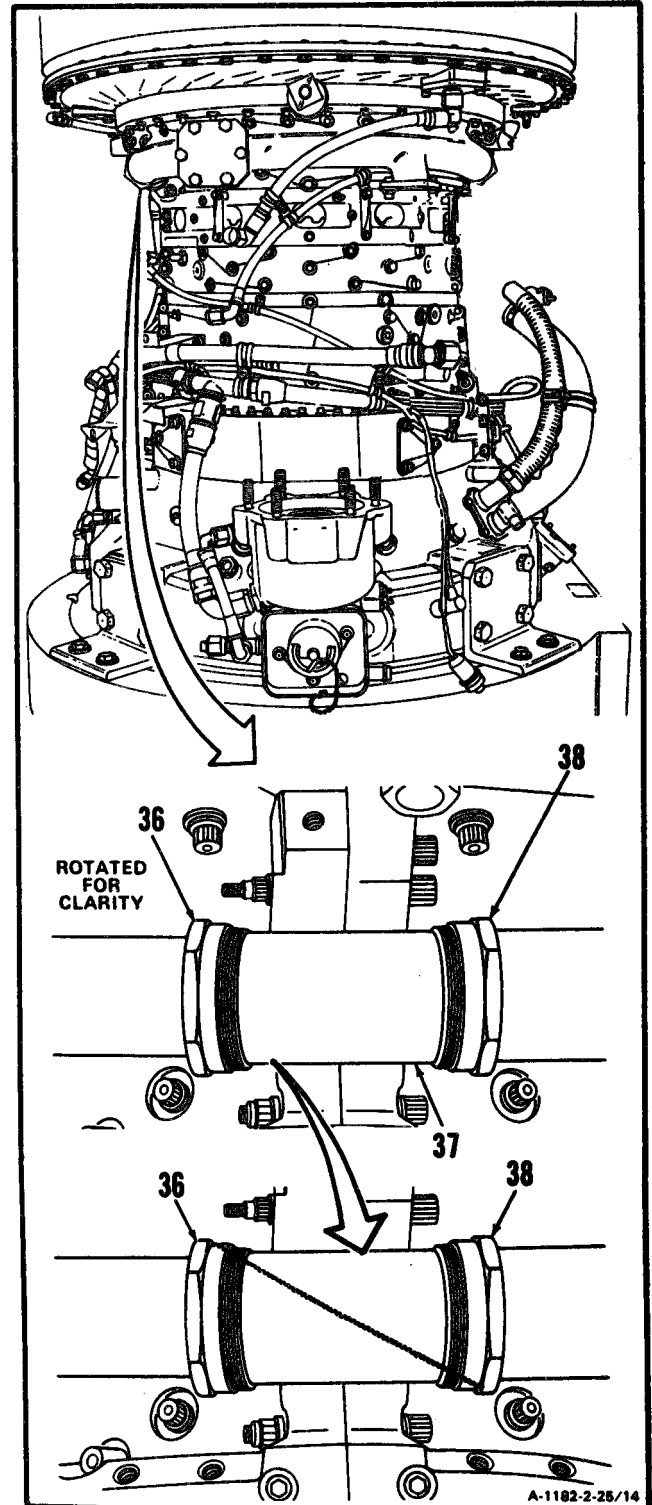

GO TO NEXT PAGE

20. Connect nut (39) to connector (40). Hand tighten nut (39). Using crowfoot attachment (T66) and 1-5/8 inch open-end wrench, torque nuts (39 and 41) to 90 inch-pounds.
21. Lockwire nuts (39 and 41). Use lockwire (E29).

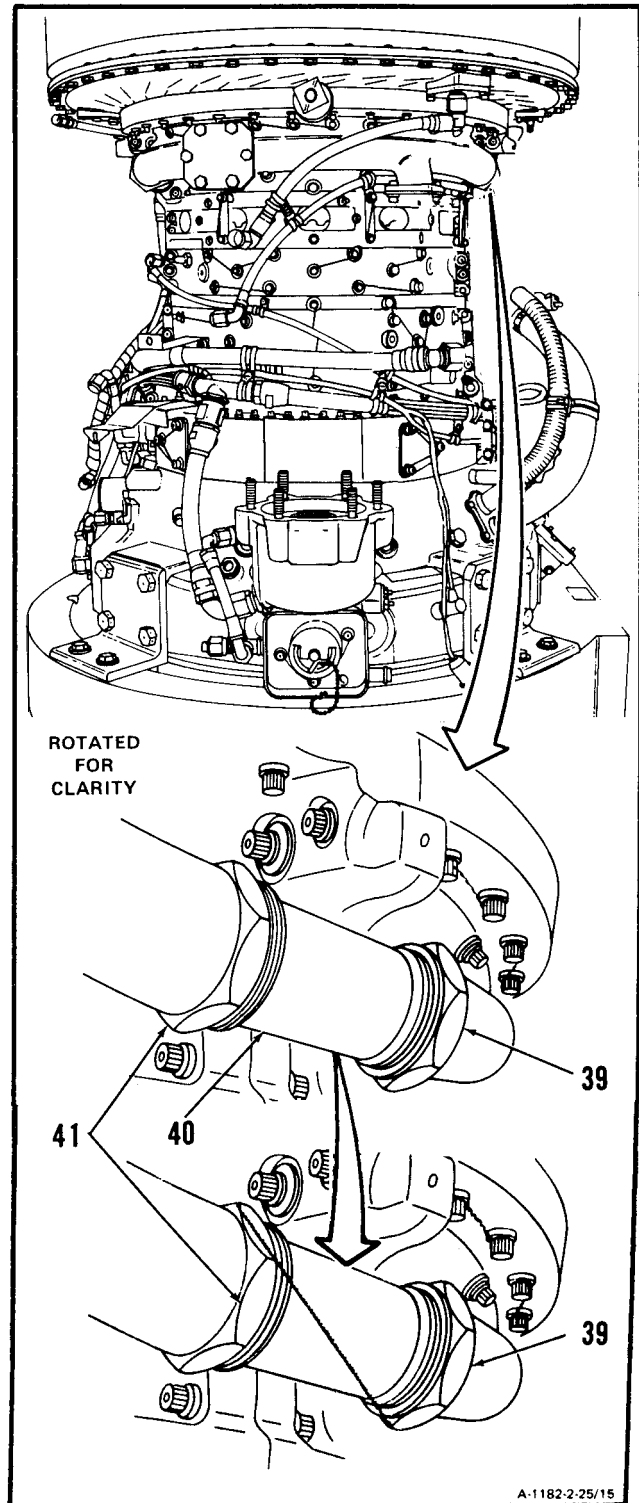

GO TO NEXT PAGE

- 22. **Position solenoid valve (42), hose assemblies (43, 44, and 45) and bracket (46) on upper compressor housing (47) as an assembly.**
- 23. **Install two spacers (48), bolts (49), washers (50), and nuts (51).**

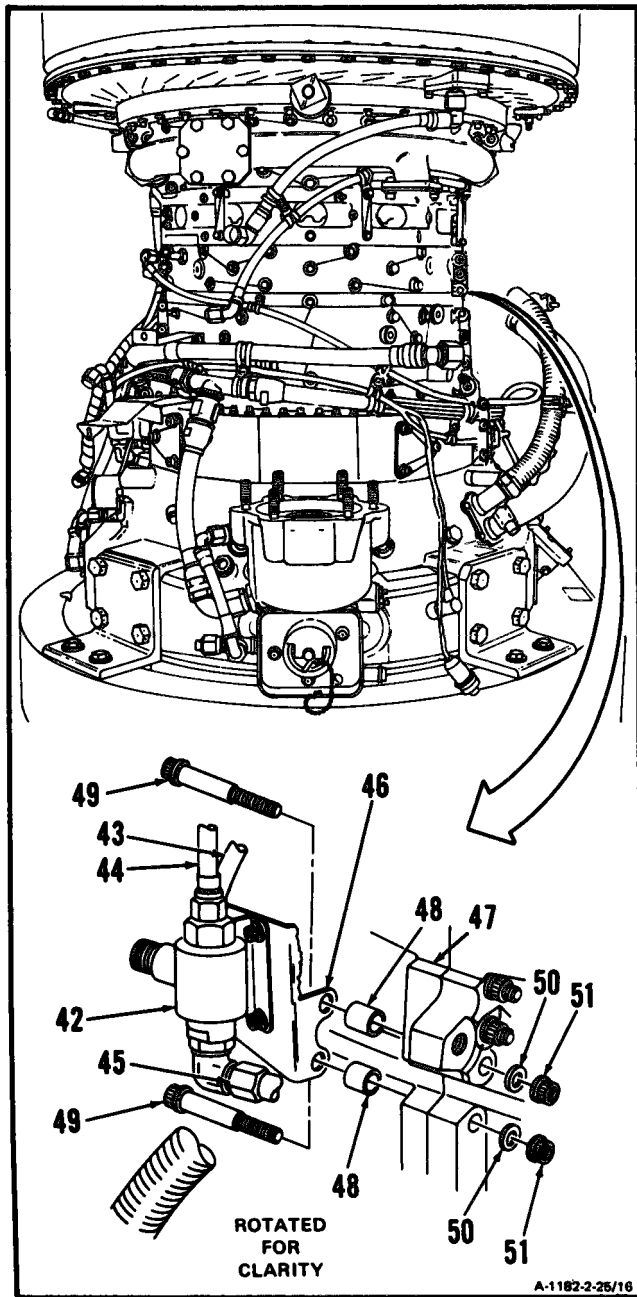

GO TO NEXT PAGE

24. Install clamp (52) and screw (53).

25. Lockwire screw (53). Use lockwire (E29).

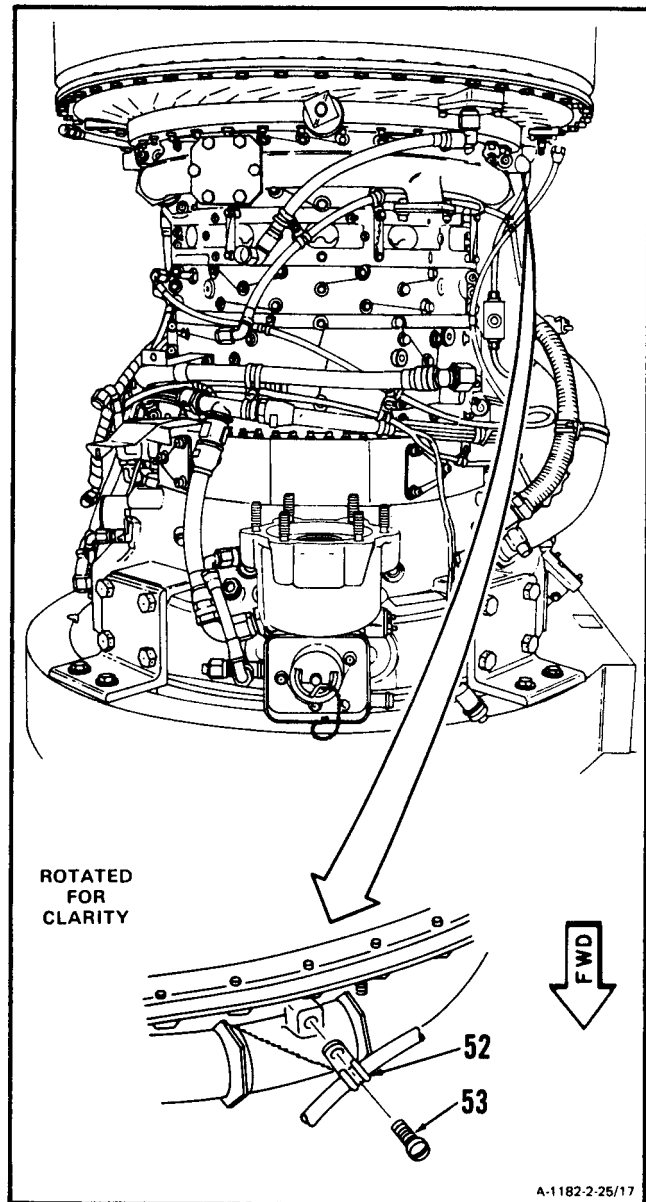

GO TO NEXT PAGE

2-25 INSTALL LOWER COMPRESSOR HOUSING (Continued)

2-25

26. Connect hose assembly (54) to adapter (55).

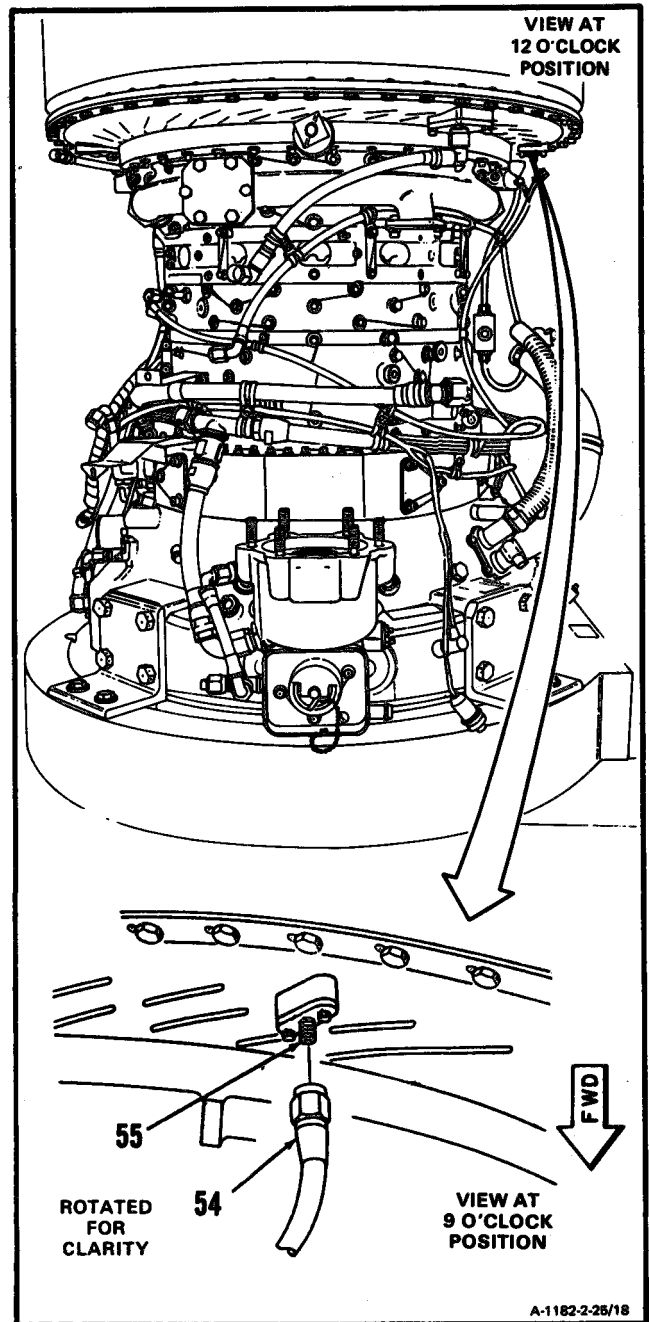

GO TO NEXT PAGE

27. Lockwire two bolts (56), Use lockwire (E29).

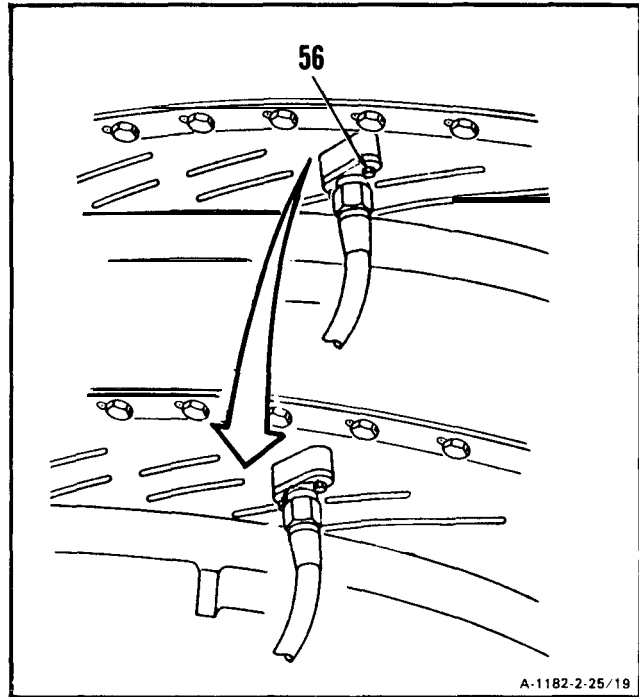

28. Install four ignition coil assembly clamps (57) with two bolts (58) and two nuts (59) to brackets (31) and (32).

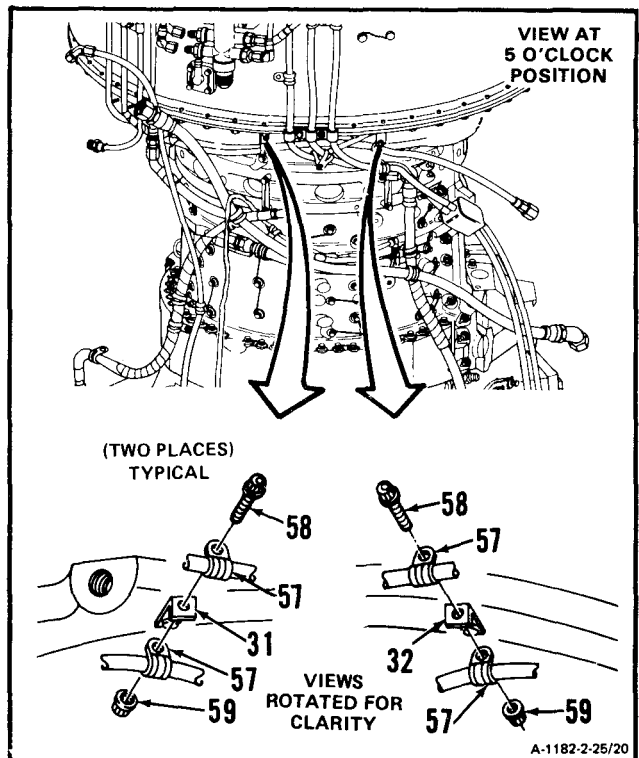

GO TO NEXT PAGE

2-25 INSTALL LOWER COMPRESSOR HOUSING (Continued)

2-25

29. **Install two spacers (60), bracket (61), two bolts (62), washers (63), and nuts (64).**
30. Install washer (65) and bolt (66).
31. Lockwire bolt (66). Use lockwire (E29).

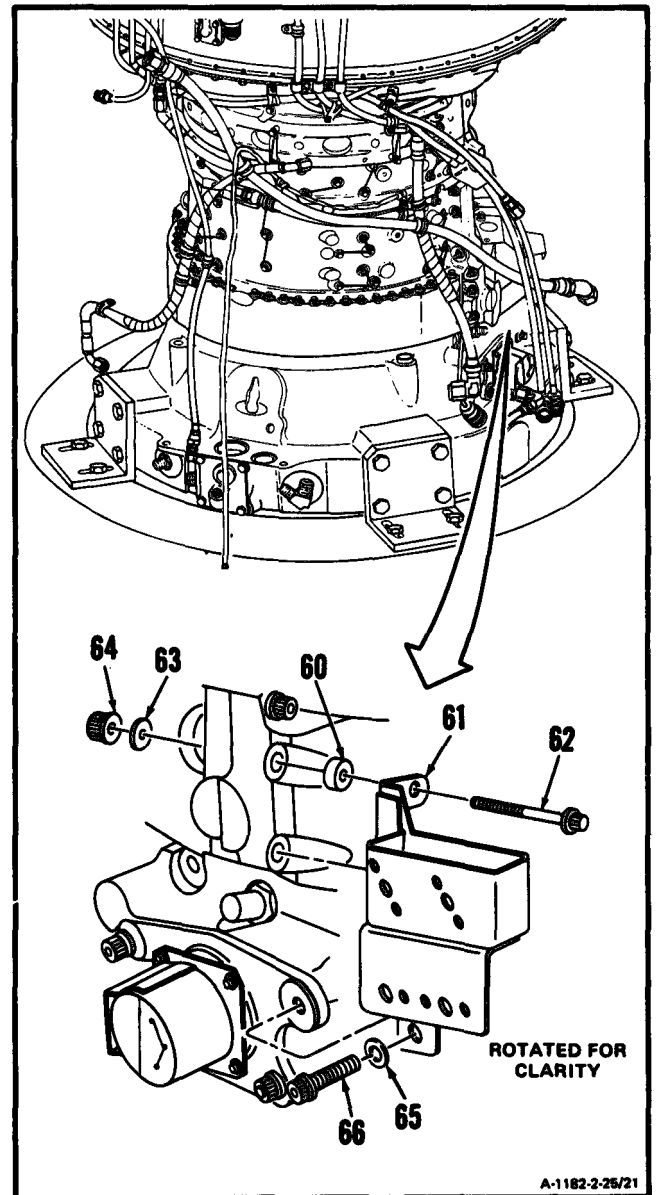
**GO TO NEXT PAGE**

32. Install spacer (67).
33. Swing bracket (68) towards housing split line (69).
34. Install two bolts (70).
35. Torque two bolts (70) to 82 inch-pounds.
lockwire bolts (70), Use lockwire (E29).

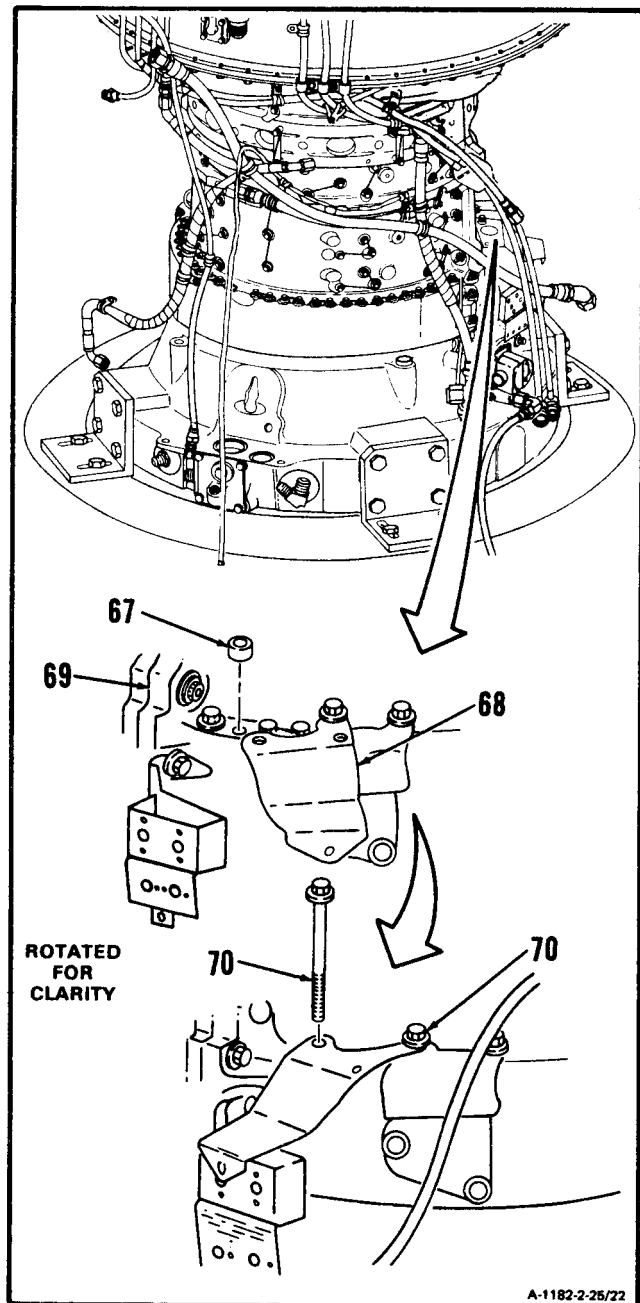

GO TO NEXT PAGE

2-25 INSTALL LOWER COMPRESSOR HOUSING (Continued)

2-25

36. **Install** packing (71), **adapter** (72), and two bolts (73).
37. Lockwire bolts (73). Use lockwire (E29).

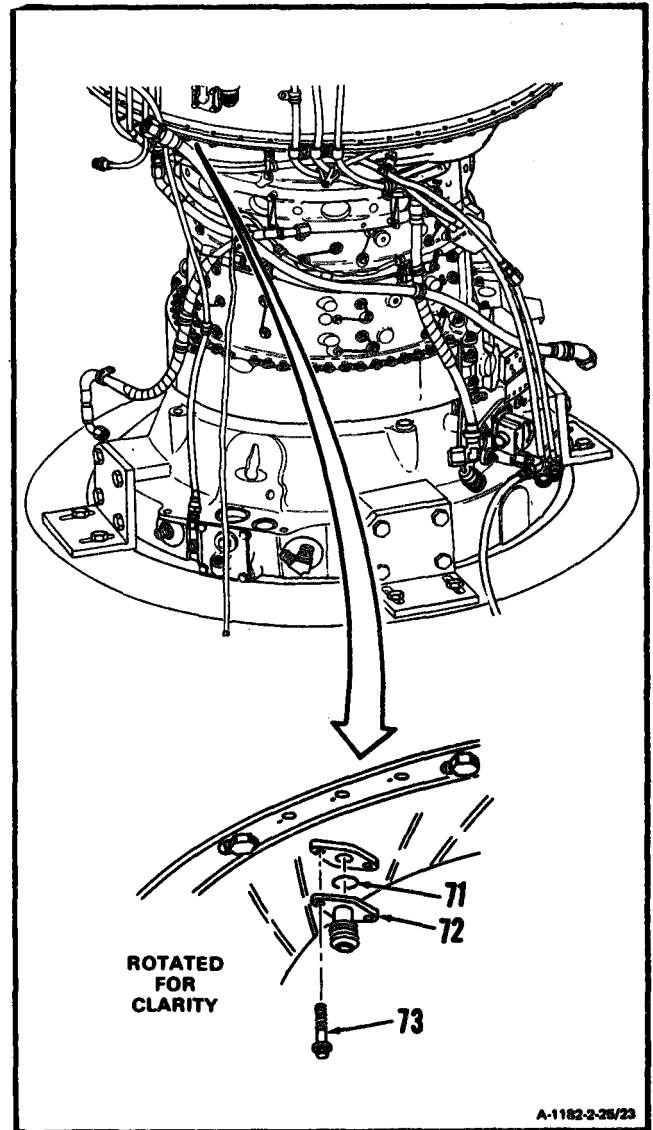

GO TO NEXT PAGE

38. Connect hose assembly (74) to adapter (72).

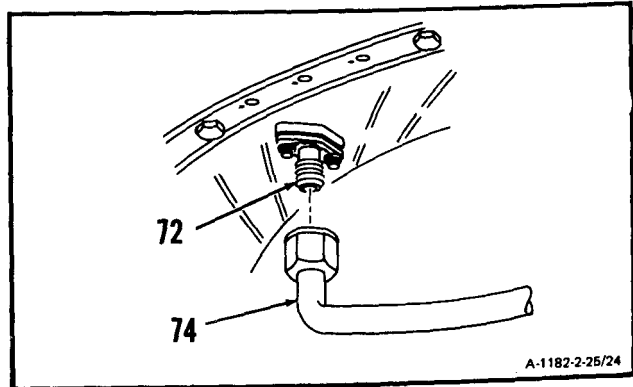

39. Install bracket (75), three key washers (76), and three bolts (77).

40. Lock three bolts (77) by bending tabs of key washers (76).

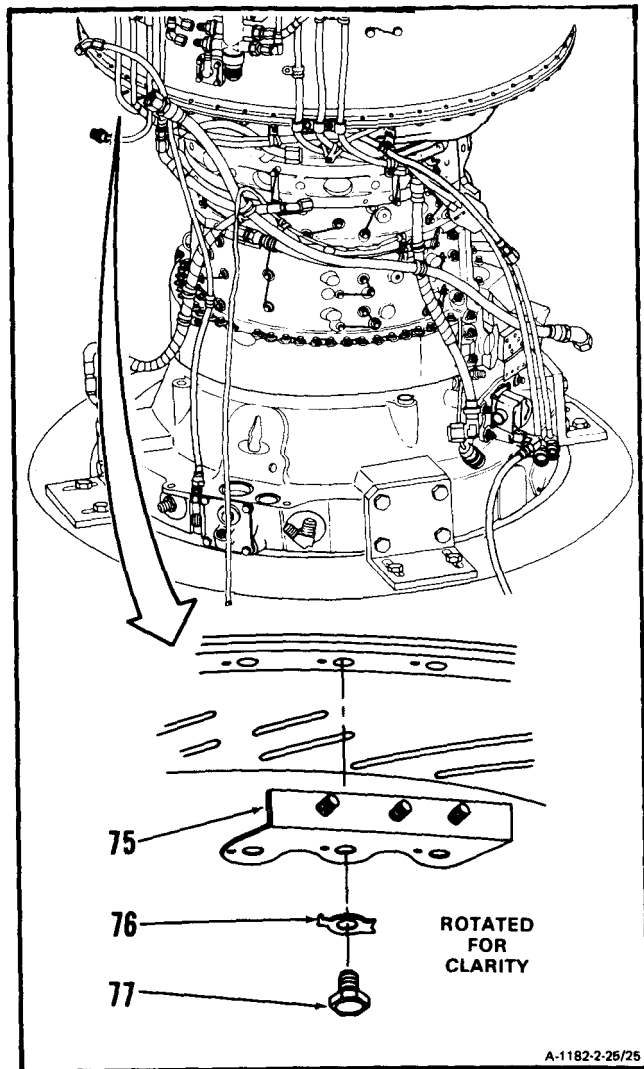

GO TO NEXT PAGE

2-25 INSTALL LOWER COMPRESSOR HOUSING (Continued)

2-25

- 41. Position hoses (78) on bracket (75).
- 42. Install clamp (79) and three nuts (80) on bracket (75).

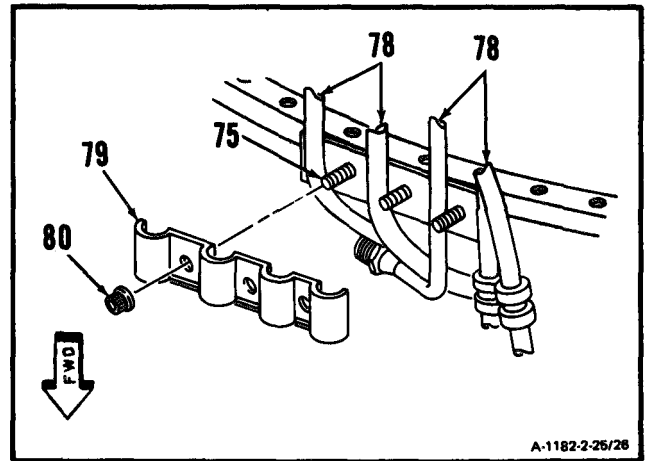

- 43. Connect hose assembly (81) to tube assembly (82).

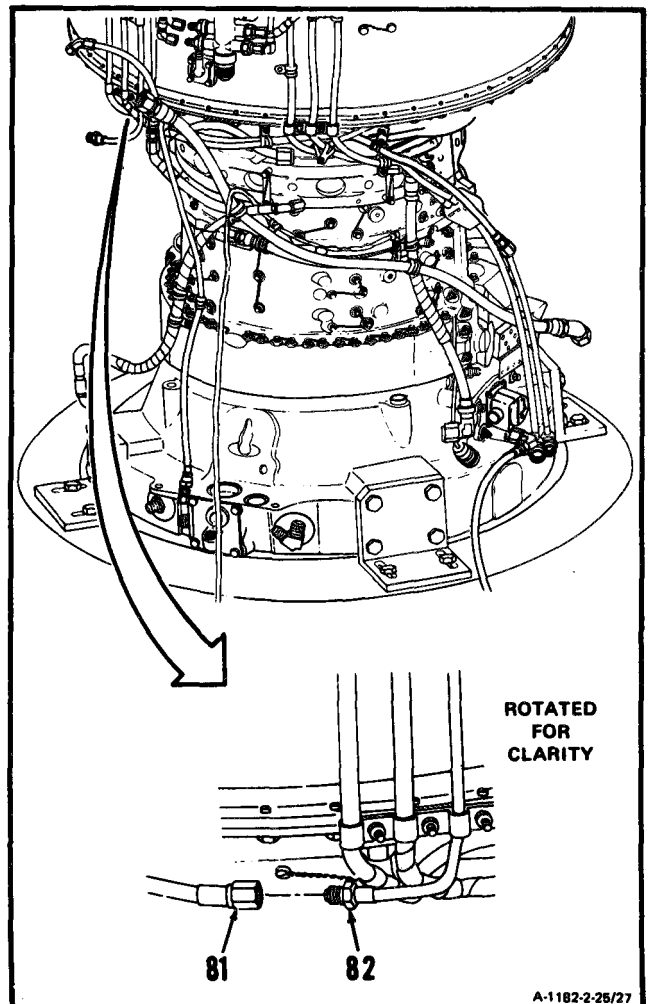

GO TO NEXT PAGE

44. Connect hose assembly (83) to union (84).

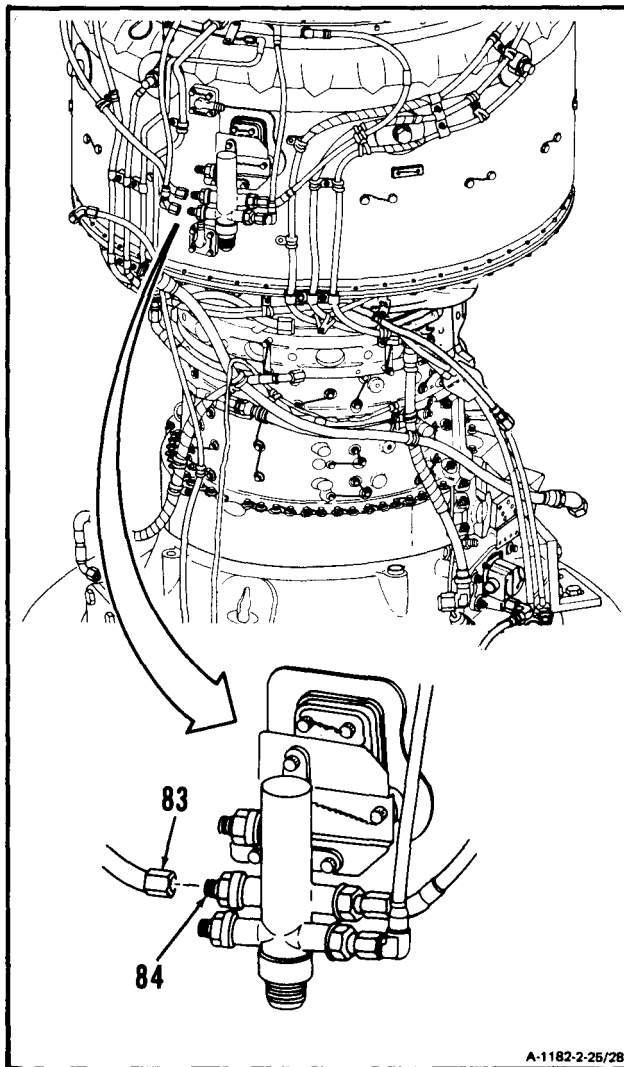

45. Connect hose assembly (85) to union (86).

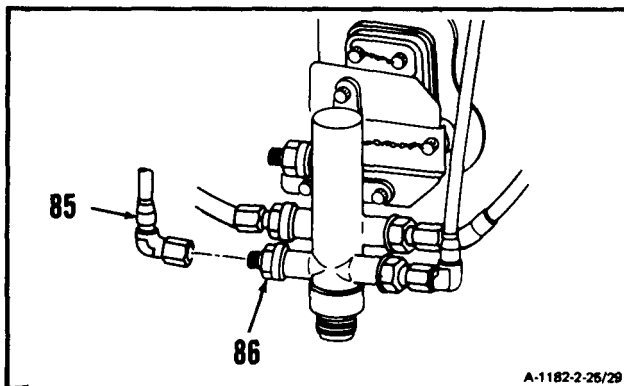

GO TO NEXT PAGE

2-25 INSTALL LOWER COMPRESSOR HOUSING (Continued)

2-25

46. **Install clamp (87)** and screw (88) to anchor nut (89). Lockwire screw (88). Use lockwire (E29).

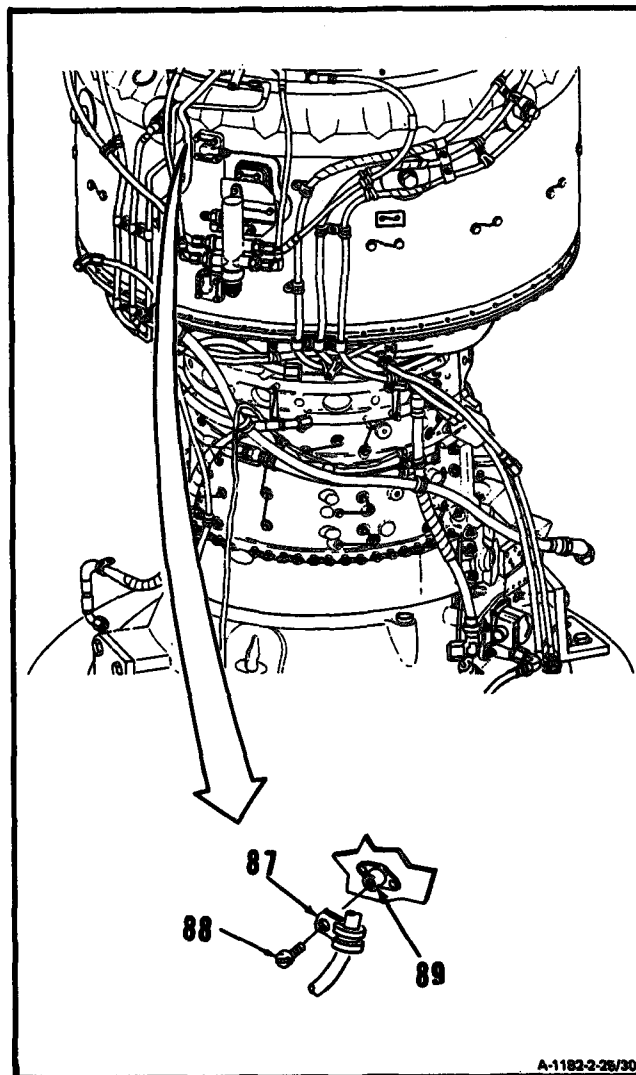

GO TO NEXT PAGE

47. **Install two clamps (90)** and screw (91) to anchor nut (92). Lockwire screw (91). Use lockwire (E29).

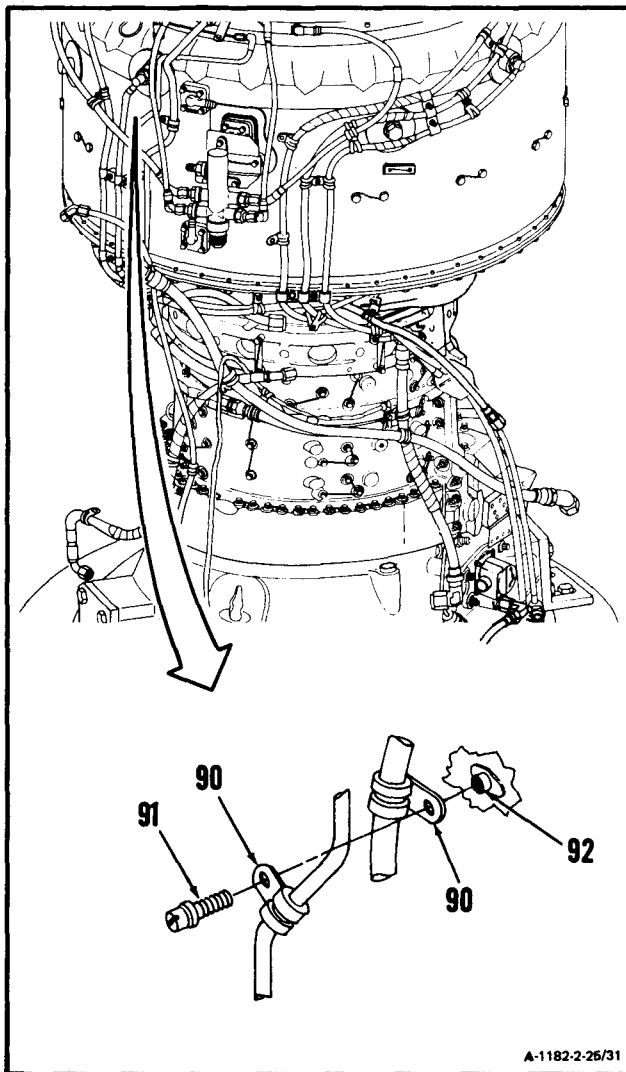

A-1182-2-26/31

GO TO NEXT PAGE

2-25 INSTALL LOWER COMPRESSOR HOUSING (Continued)

2-25

48. Install two clamps (93), screw (94) and nut (95).

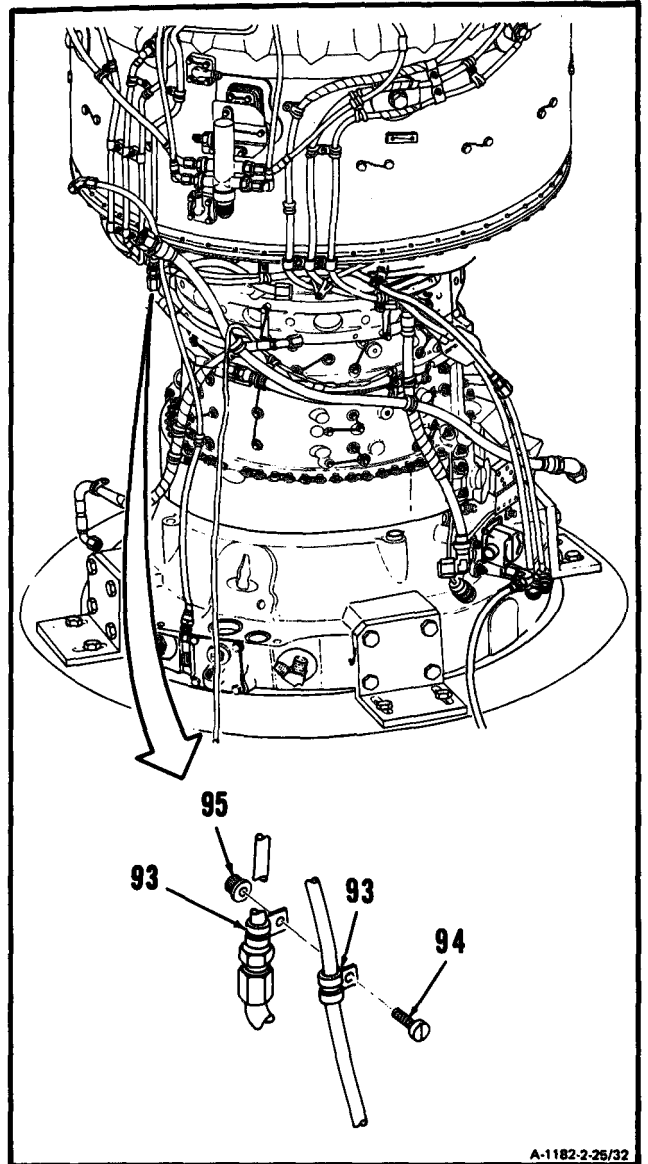

GO TO NEXT PAGE

49. **Connect hose assembly (96) to flow divider check valve (97).**

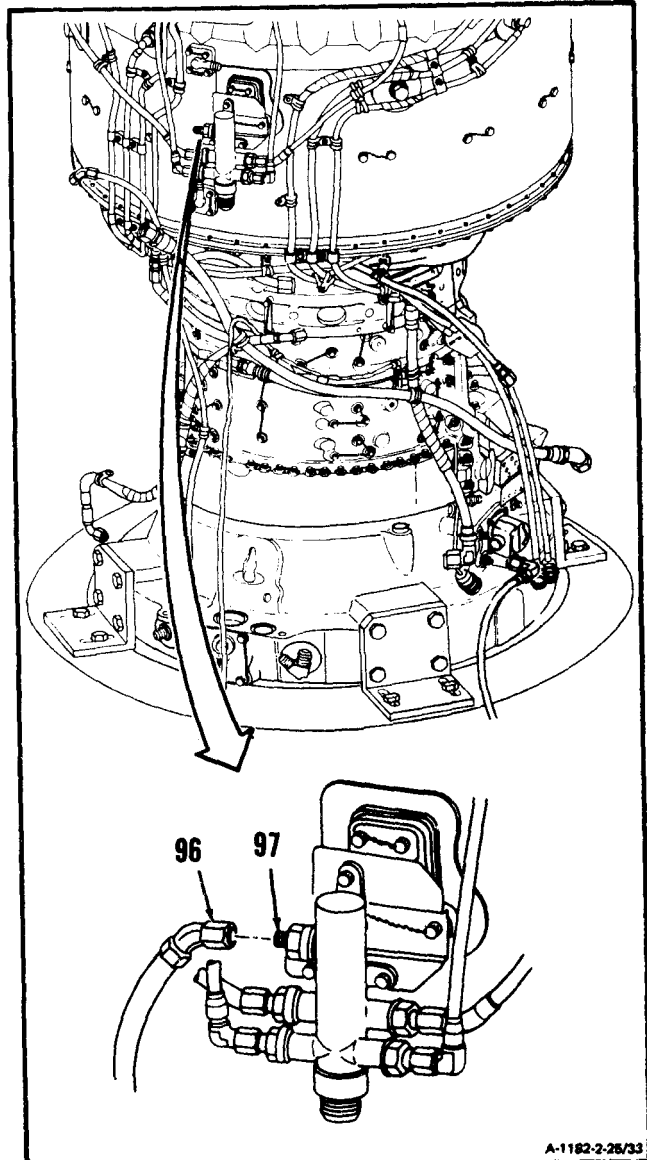

A-1182-2-25/33

GO TO NEXT PAGE

50. Connect hose assembly (98) to flow divider (99).

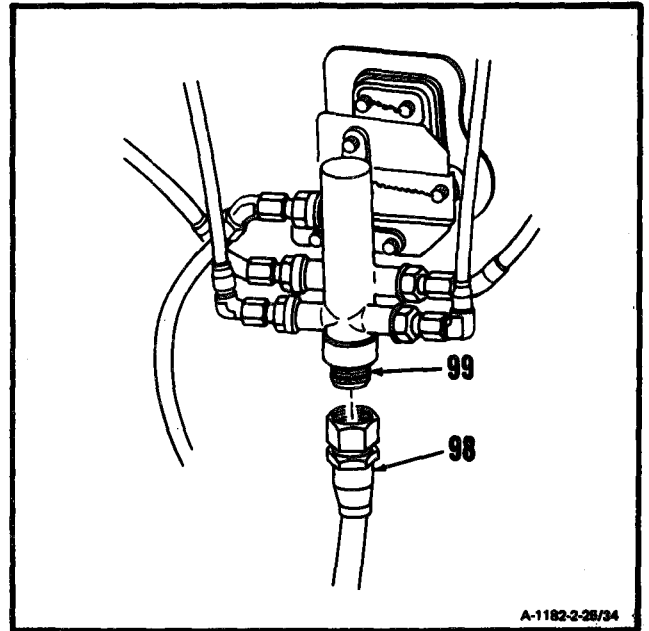

51. Install bracket (100), two key washers (101) and two bolts (102).

52. Lock two bolts (102) by bending tabs of key washers (101).

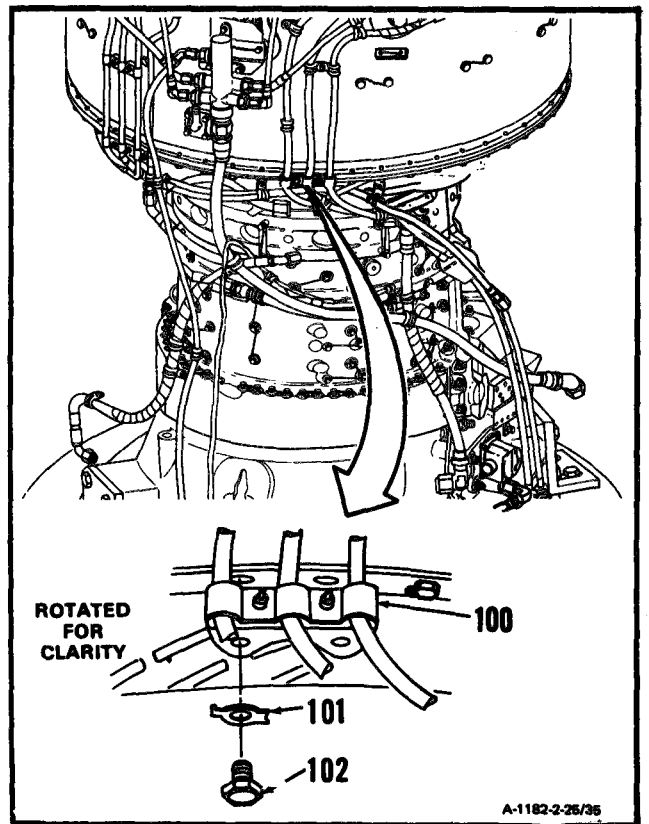

GO TO NEXT PAGE

53. Install bracket (103), key washer (104), and bolt (105).

54. Lock bolt (105) by bending tab of key washer (104).

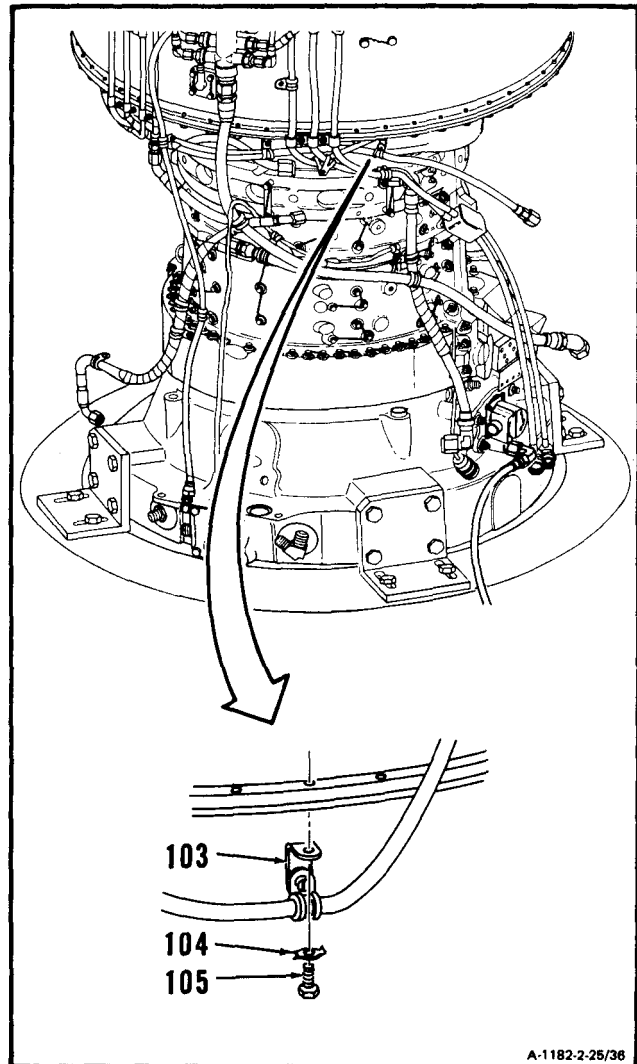

A-1182-2-25/38

GO TO NEXT PAGE

2-25 INSTALL LOWER COMPRESSOR HOUSING (Continued)

2-25

55. Install clamp (106), screw (107) and nut (108).

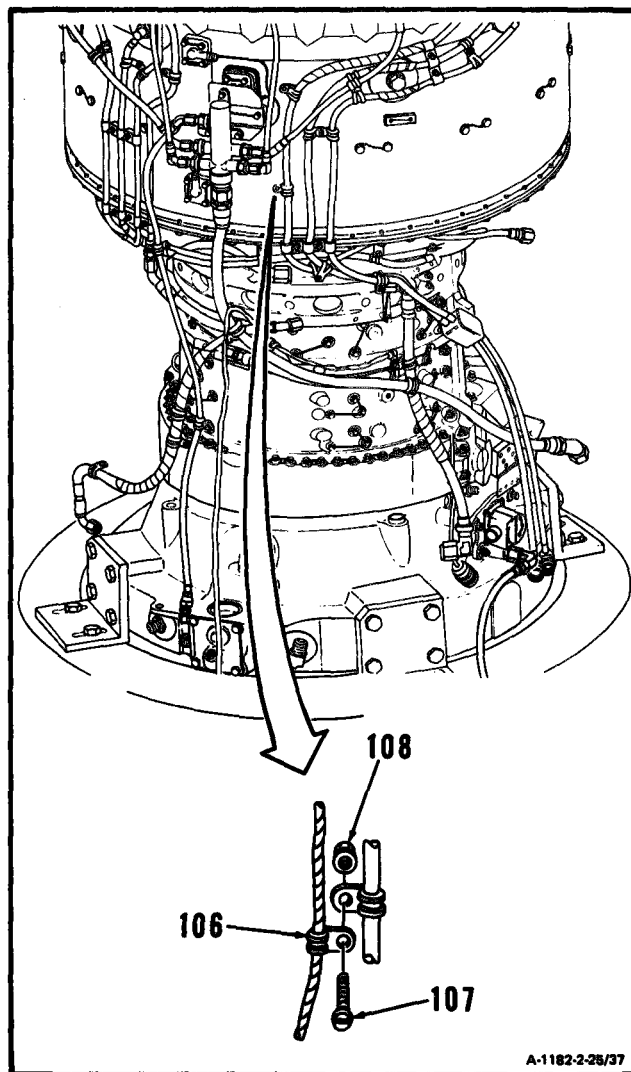

GO TO NEXT PAGE

56. Install clamp (109) and screw (110) to anchor nut (111). Lockwire screw (110). Use lockwire (E29).

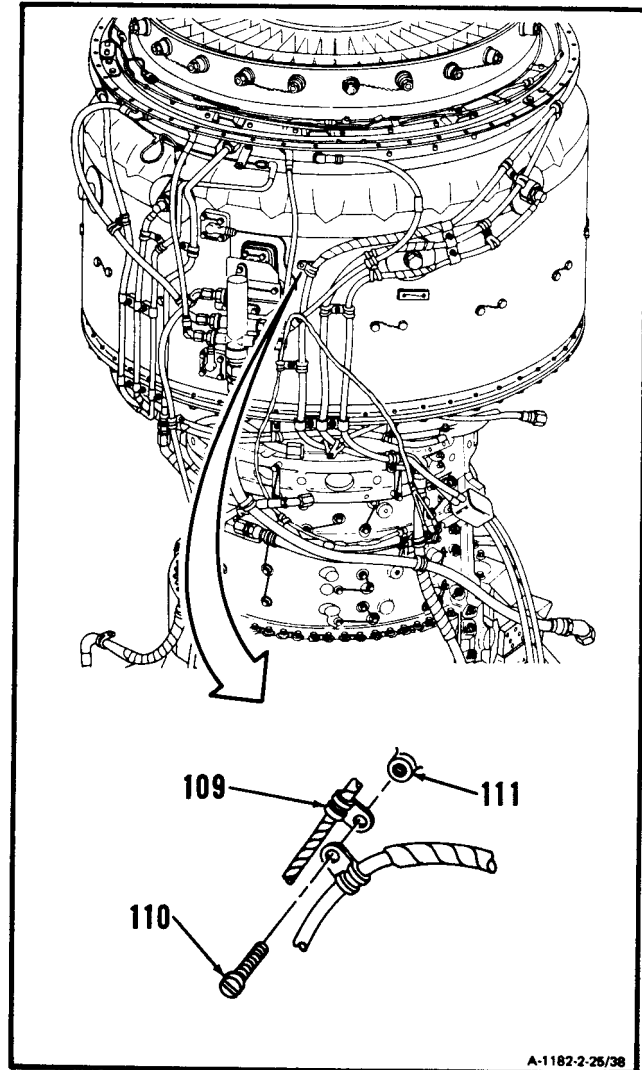

GO TO NEXT PAGE

2-25 INSTALL LOWER COMPRESSOR HOUSING (Continued)

2-26

57. Route thermocouple leads (112) through fire-shield (113).
58. **Install bracket (114)**, two bolts (115) and nuts (116).

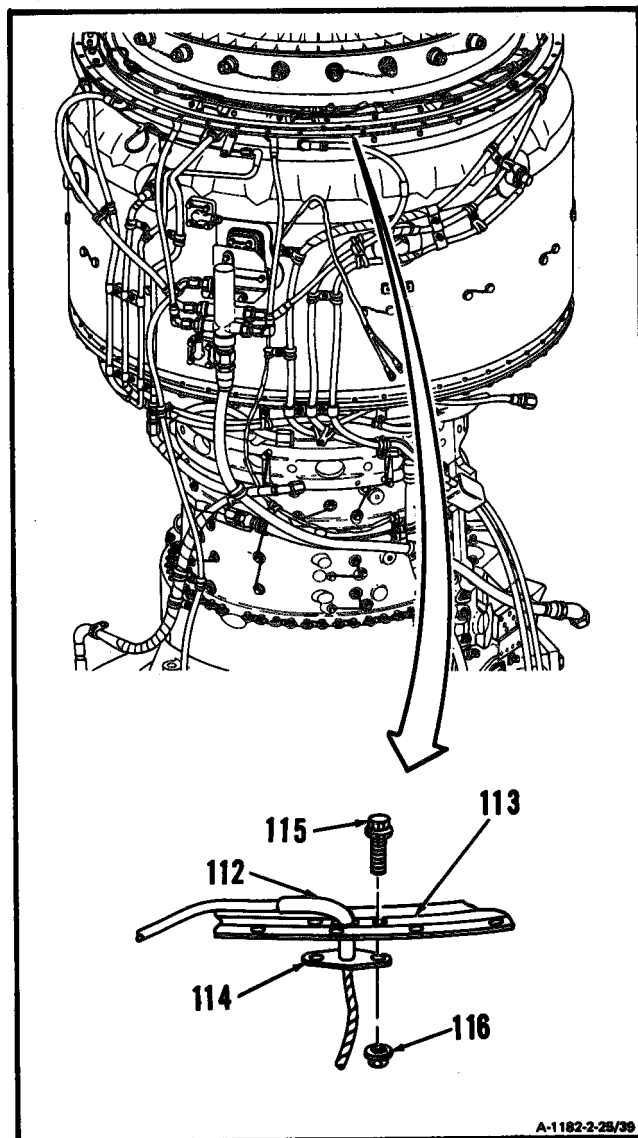

GO TO NEXT PAGE

59. Install green sleeved terminal lug (117) between terminal lugs (118 and 119) and install screw (120).

60. Install white sleeved terminal lug (121) between terminal lugs (122 and 123) and install screw (120).

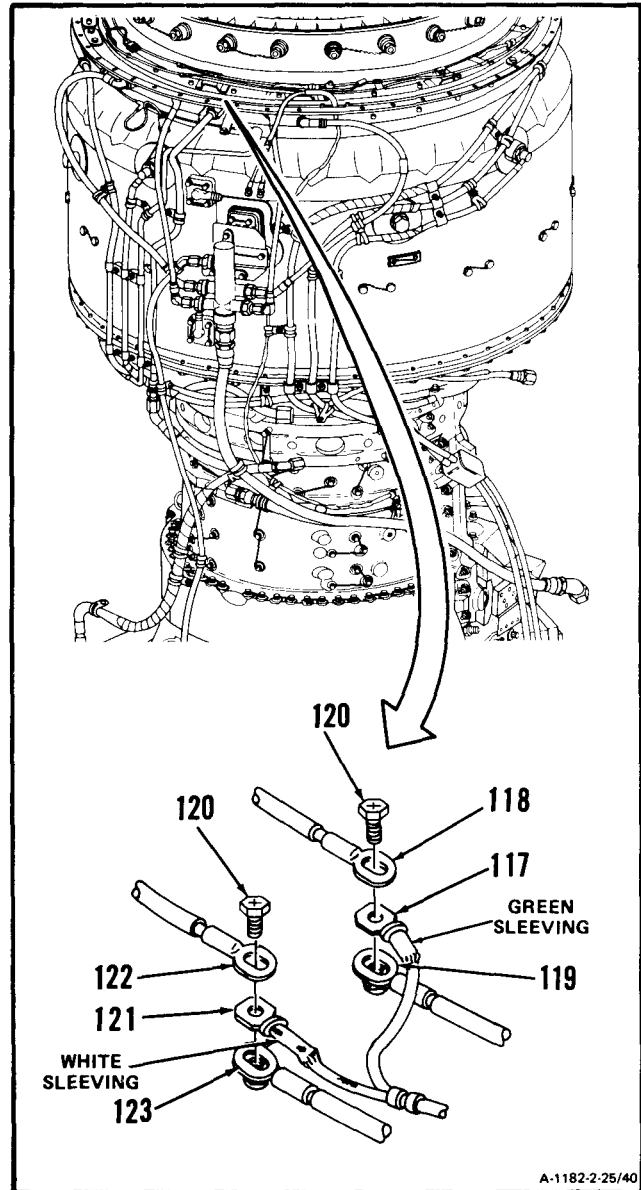

GO TO NEXT PAGE

2-25 INSTALL LOWER COMPRESSOR HOUSING (Continued)

2-25

61. **Install** two spacers (124), **bracket (125)**, washers (126) and bolts (127). Lockwire bolts (127). We lockwire (E29).

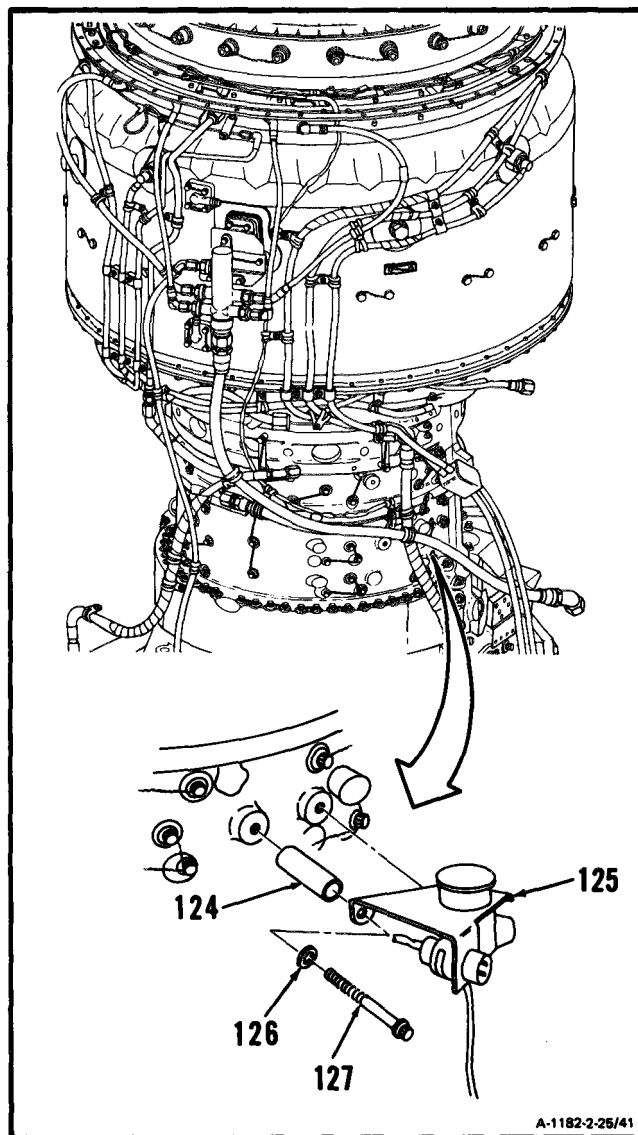

GO TO NEXT PAGE

62. **Connect electrical cable (128) to receptacle (129).**

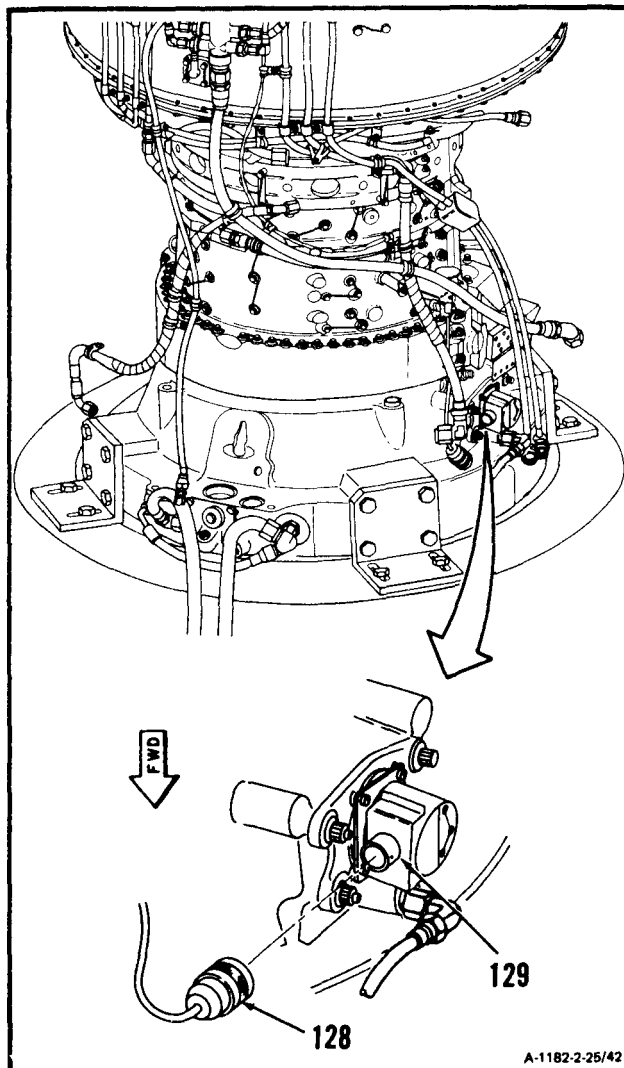

GO TO NEXT PAGE

63. Install ignition coil (130), two bolts (131) and nuts (132) on bracket (133).

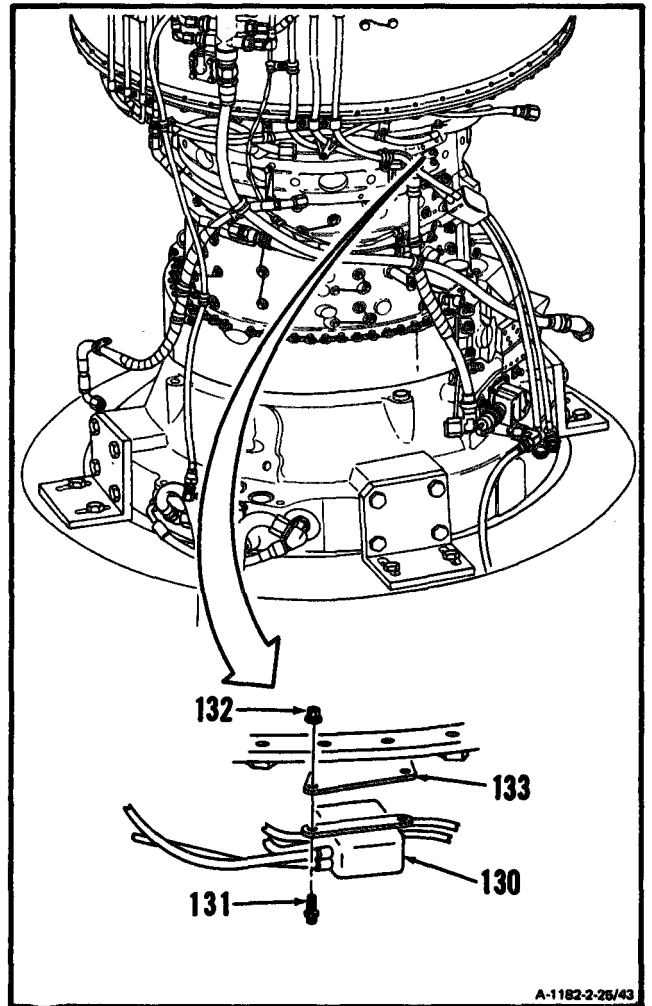

A-1182-2-25/43

GO TO NEXT PAGE

64. Install packing (134), connector (135) and two bolts (136).

65. Lockwire two bolts (136). Use lockwire (E29).

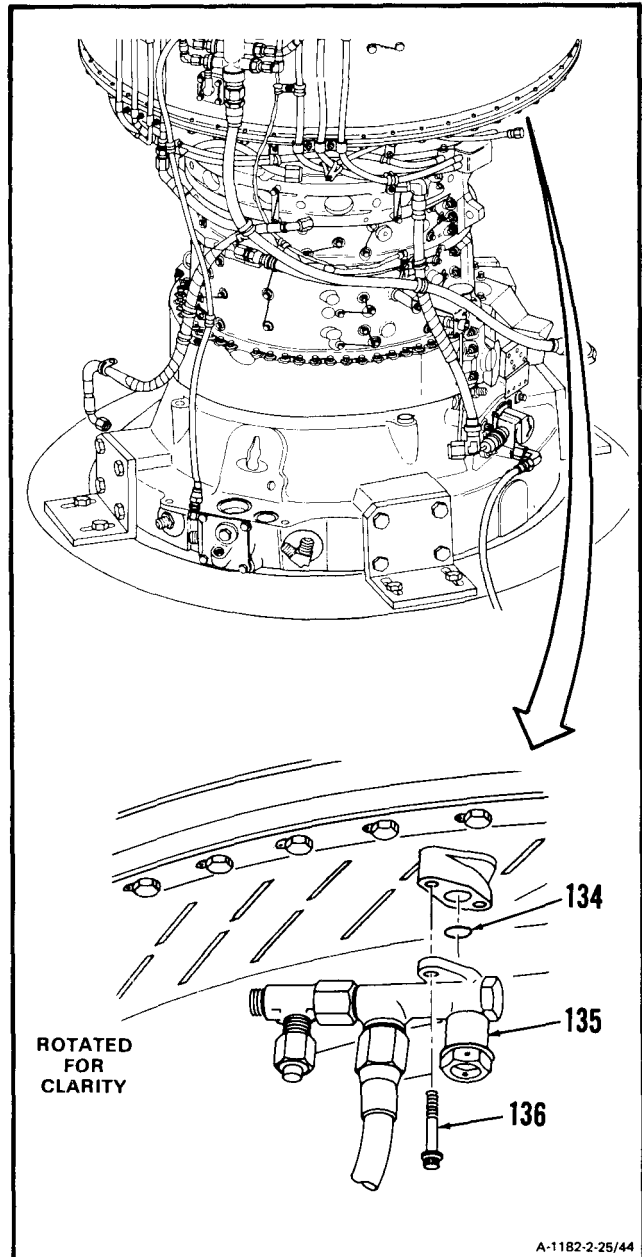

GO TO NEXT PAGE

66. Connect hose assembly (137) to tee and snubber (138).

INSPECT

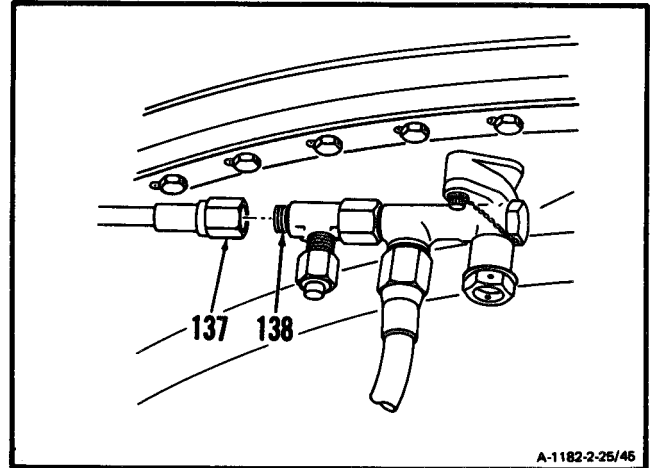

A-1182-2-25/45

FOLLOW-ON MAINTENANCE:

- Install Compressor Bleed Band (Task 2-13).
- Install Interstage Air-Bleed Actuator (Task 2-7).
- Install Main Fuel Filter and Bracket (Task 6-35).
- Install Accessory Gearbox Assembly (Task 5-7).
- Install Fuel Control (Task 6-6).
- Install Main Oil Pump and Scavenge Oil Screen (Task 8-4).
- Install Tube Assembly (Inlet Housing to Main Oil Pump) (Task 8-51).
- Install Fuel Boost Pump Assembly (Task 6-13).
- Install Dual Chip Detector (Task 8-35).
- Install In-Line Fuel Filter Assembly (Task 6-41).
- Install Oil Cooler Assembly (Task 8-11).
- Install Ignition Exciter (Task 7-15).
- Service Engine Oil System (Task 1-74).

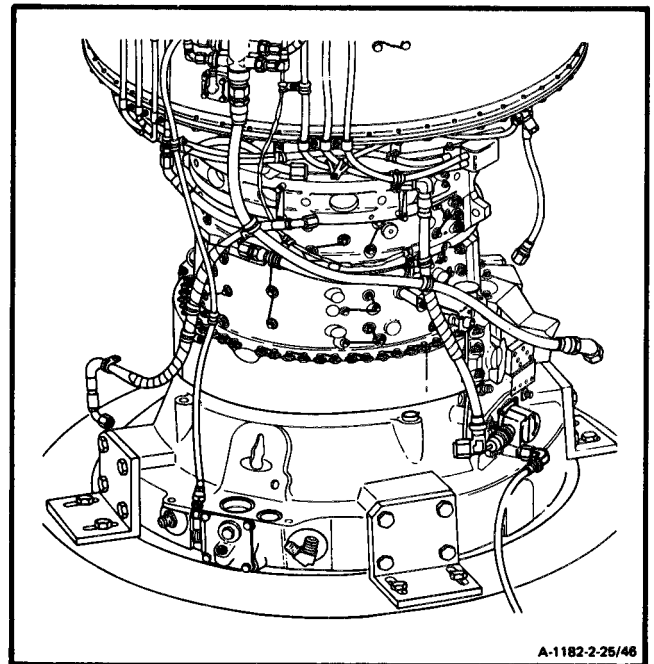

A-1182-2-25/46

END OF TASK

Section V. STATOR VANE ASSEMBLIES - MAINTENANCE PROCEDURES

2-26 REMOVE STATOR VANE ASSEMBLIES

2-26

INITIAL SETUP

Applicable Configurations:

Tools:

Powerplant Mechanic's Tool Kit,
NSN 5180-00-323-4944

Materials:

Tag (E53)
Dry Cleaning Solvent (E17)
Gloves (20)
Lint-Free Cloth (E26)

Personnel Required:

68B10 Aircraft Powerplant Repairer

Equipment Condition:

Engine Oil System Drained (Task 1-75)
Oil Cooler Assembly Removed (Task 8-5)
(Mine Fuel Filter Assembly Removed (Task 6-36)
Ignition Exciter Removed (Task 7-11)
Oil Filler Assembly and Oil Filler Strainer Removed (Task 8-16)
(Upper Compressor Housing Only)

Starter Drive Assembly Removed (Task 512) (Upper Compressor Housing Only)
Main Fuel Filter and Bracket Removed mask 6-29)
Dual Chip Detector Removed (Task 8-28) (Lower Compressor Housing Only)
Fuel Boost Pump Assembly Removed (Task 6-9) (Lower Compressor Housing Only)
Tube Assembly (Inlet Housing to Main Oil Pump) Removed (Task W50) (Lower Compressor Housing Only)
Main Oil Pump and Scavenge Oil Screen Removed (Task 8-1) (Lower Compressor Housing Only)
Fuel Control Removed (Task 6-1) (Lower Compressor Housing Only)
Accessory Gearbox Removed (Task 5-1) (Lower Compressor Housing Only)
Interstate Air-Bleed Actuator Removed (Task 2-1)
Compressor Bleed Band Removed

Compressor Housing Removed (Task 2-9 or 2-20)

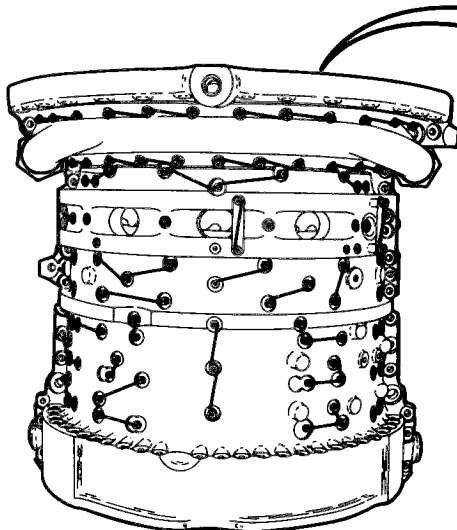

42 x 18

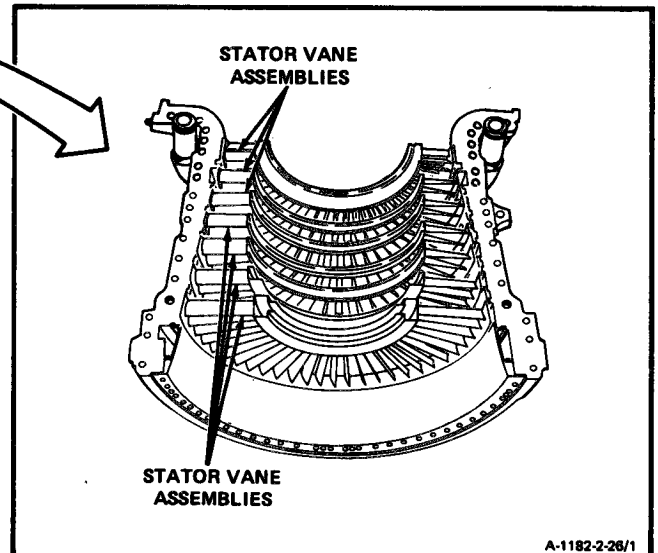

A-1182-2-26/1

GO TO NEXT PAGE

NOTE

To help in installation, tag (E53) each stator vane assembly as they are removed.

NOTE

Procedures for removing upper and lower compressor housing stator vane assemblies are the same. Instructions for removing lower compressor housing stator vane assemblies are given.

1. Remove lockwire, eight bolts (1), and washers (2) from bolt locations (3).
2. **Remove one-half of first stage stator vane (4)** from lower compressor housing (5).
- 2.1. Remove RTV potting compound from outer shroud (5.1) of stator vane (4) and from mounting surface (5.2) of first stage stator vane (4).

WARNING

Dry cleaning solvent (E17) is flammable and toxic. It can irritate skin and cause burns. Use only in well-ventilated area, away from heat and open flame. In case of contact, immediately flush skin or eyes with water for at least 15 minutes. Get medical attention for eyes.

- 2.2. If necessary, remove excess RTV potting compound from mounting surface (5.2) of first stage stator vane using gloves (E20) and lint-free cloth (E26) dampened in dry cleaning solvent (E17).
- 2.3. Wipe dry using dry, lint-free cloth (E26).

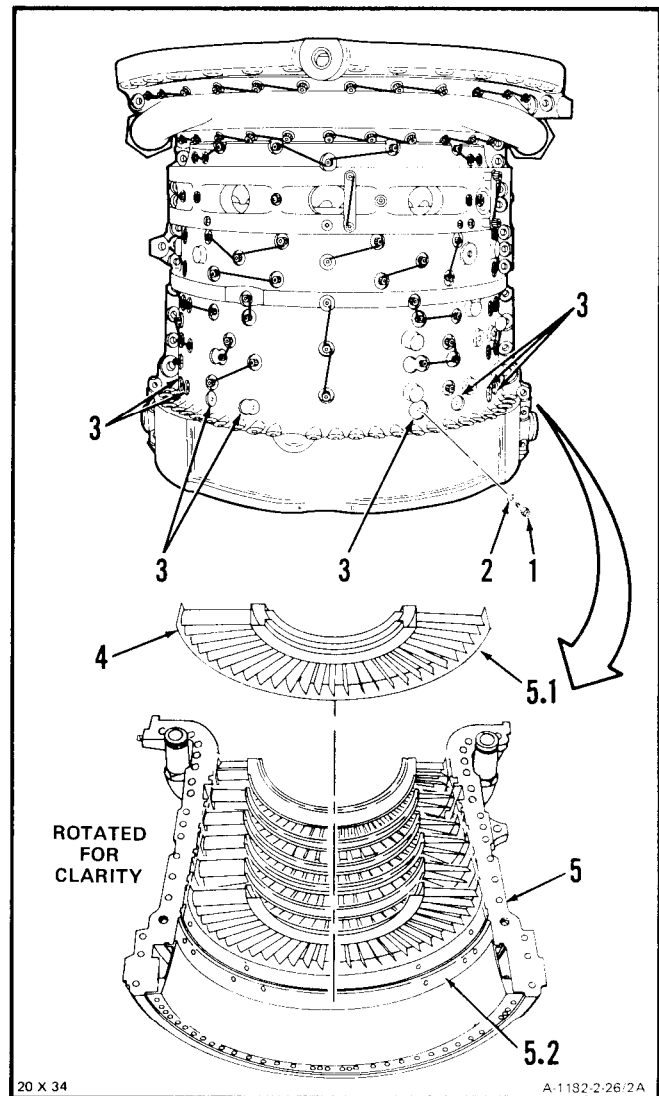

GO TO NEXT PAGE

2-26 REMOVE STATOR VANE ASSEMBLIES (Continued)

2-26

3. Remove lockwire, eight bolts (6), and washers (7) from bolt locations (8).
4. Remove one-half of second stage stator vane (9) from lower compressor housing (5).

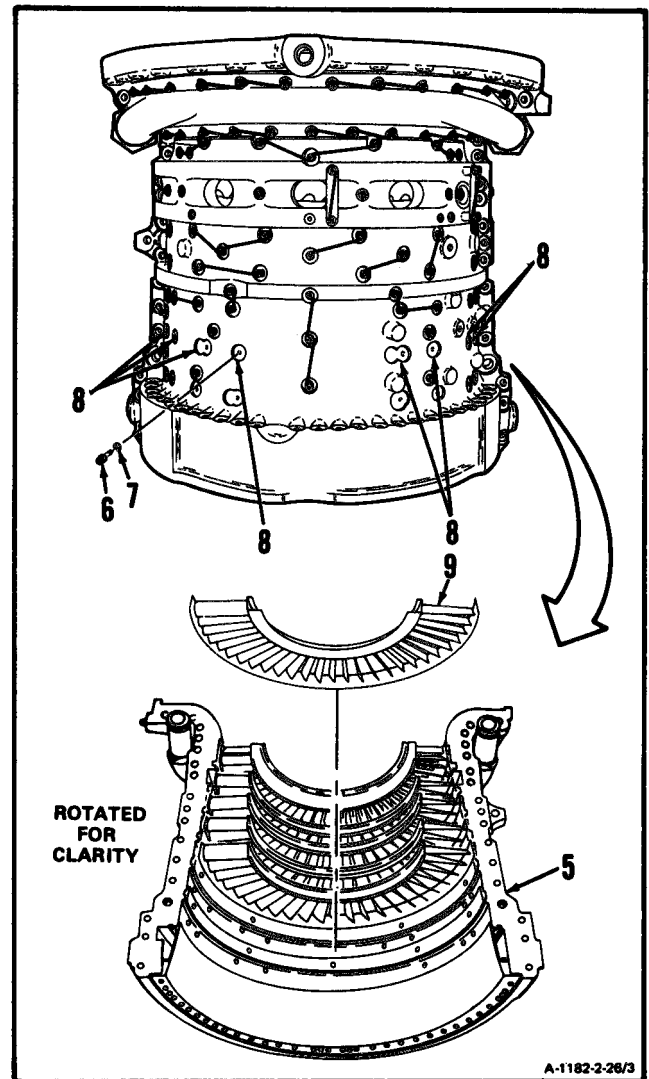
**GO TO NEXT PAGE**

5. Remove lockwire, eight bolts (10), and washers (11) from bolt locations (12).
6. Remove one-half of third stage stator vane (13) from lower compressor housing (5).

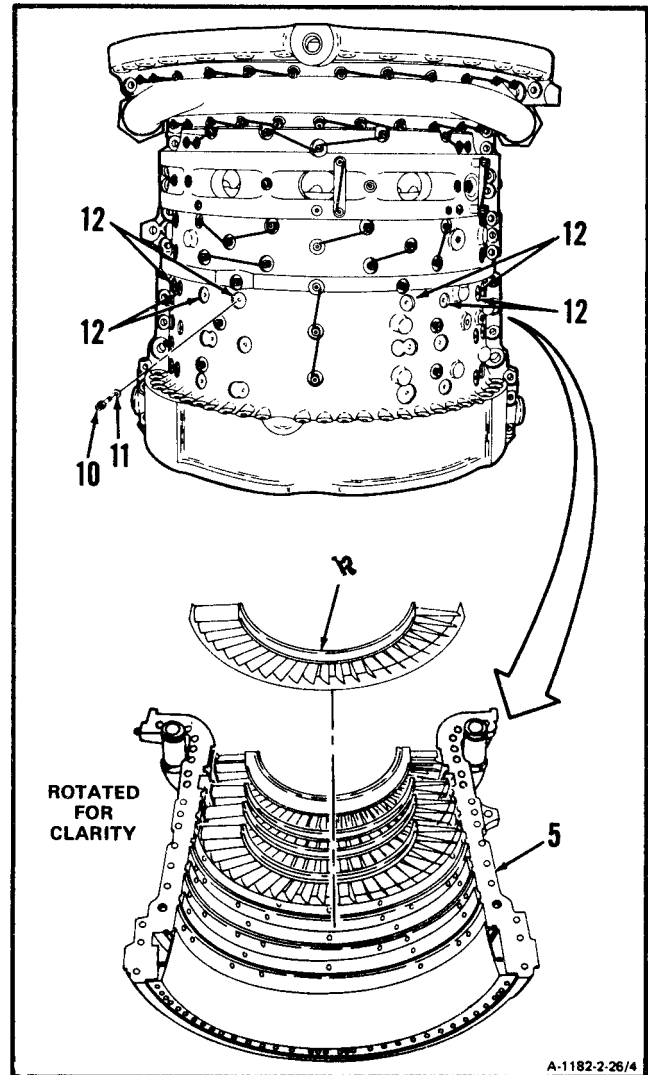

GO TO NEXT PAGE

2-26 REMOVE STATOR VANE ASSEMBLIES (Continued)

2-26

7. Remove lockwire, six bolts (14), and washers (15) from bolt locations (16).
8. Remove one-half of fourth stage stator vane (17) from lower compressor housing (5).

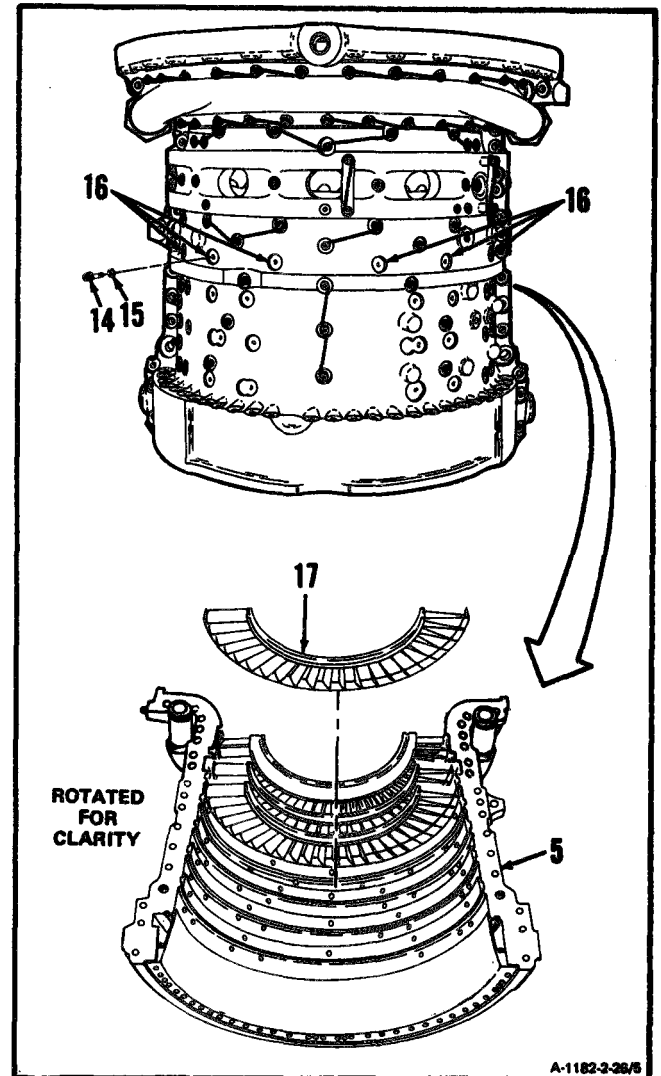

GO TO NEXT PAGE

9. Remove lockwire, six bolts (18), and washers (19) from bolt locations (20).
10. **Remove one-half of fifth stage stator vane (21) from lower compressor housing (5).**

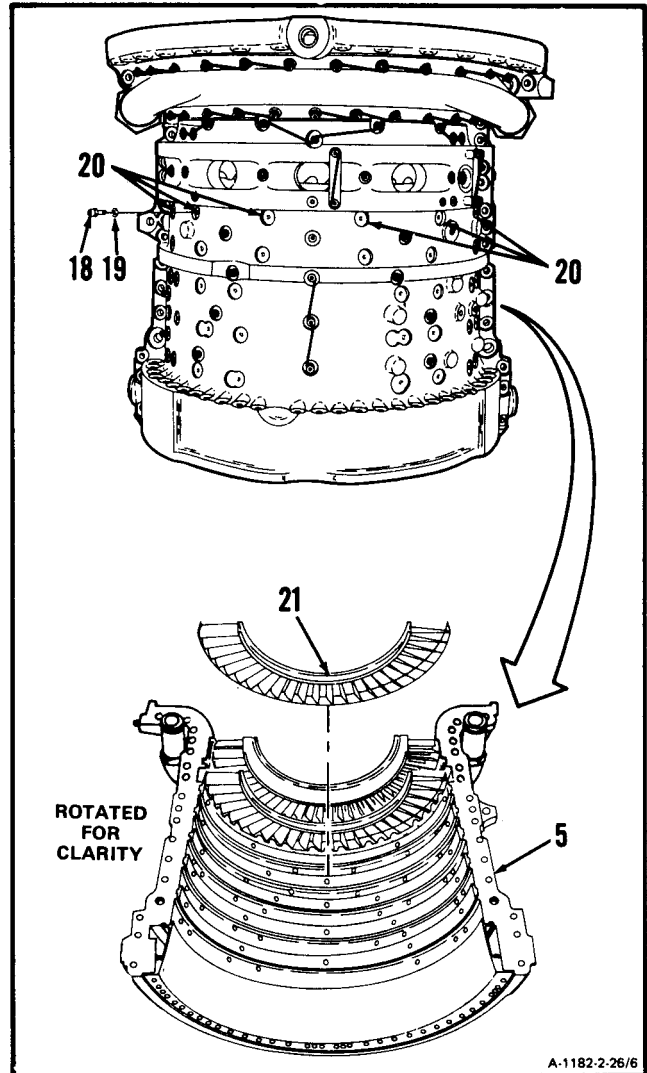

GO TO NEXT PAGE

2-26 REMOVE STATOR VANE ASSEMBLIES (Continued)

2-26

11. Remove six screws (22) and six locking cups (23) from bolt locations (24).
12. Remove one-half of sixth stage stator vane (25) from lower compressor housing (5).

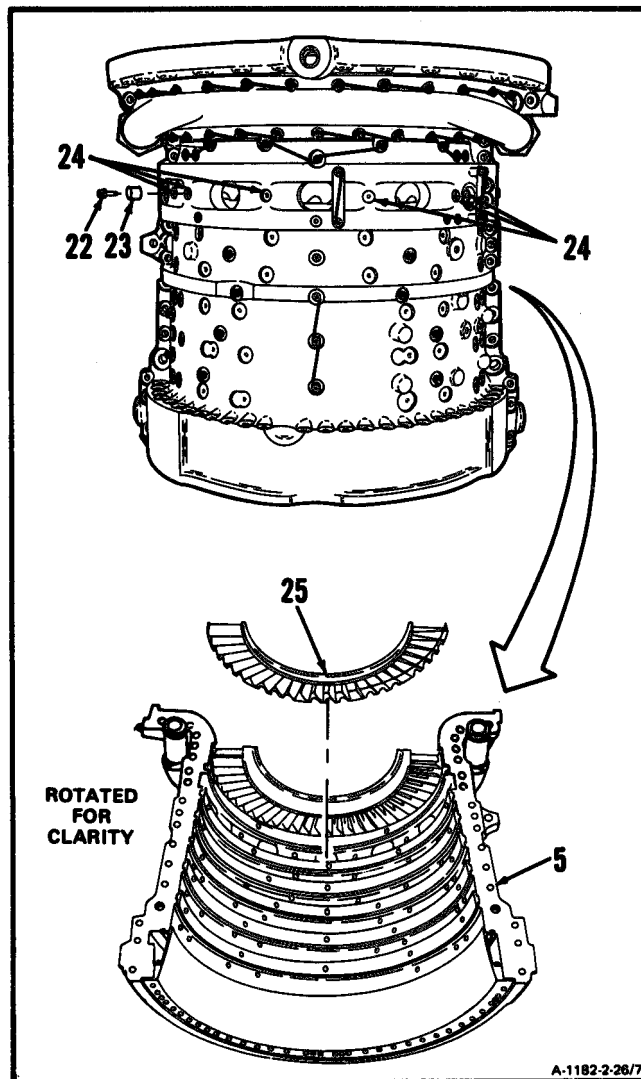

GO TO NEXT PAGE

13. Remove lockwire, nine bolts (26) and nine washers (27) from bolt locations (28).
14. **Remove one-half of seventh stage stator vane (29) from lower compressor housing (5).**

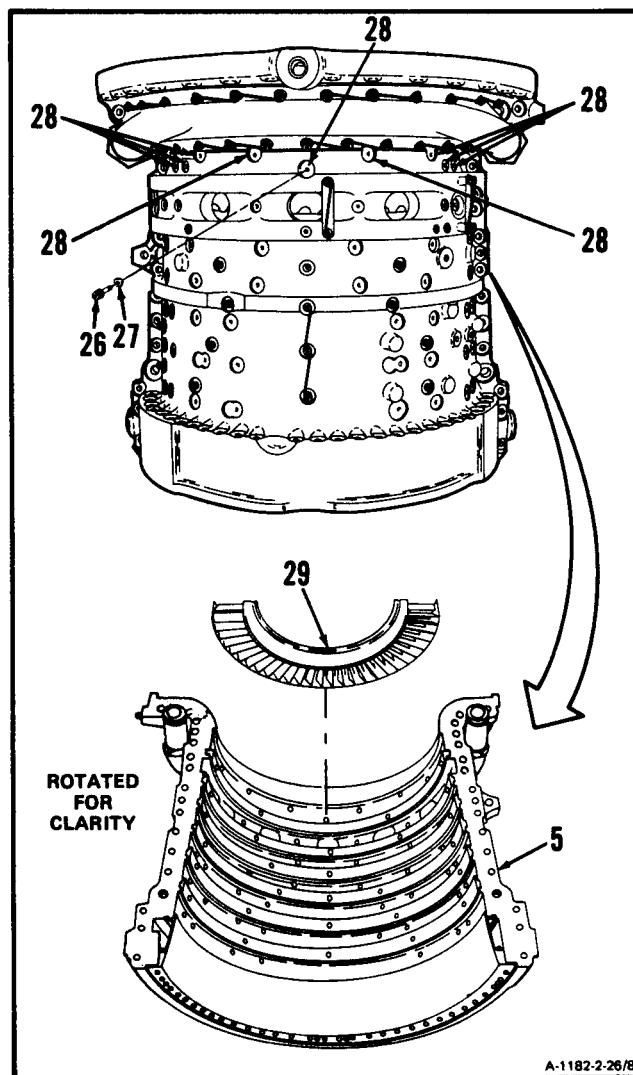

GO TO NEXT PAGE

FOLLOW-ON MAINTENANCE:

None

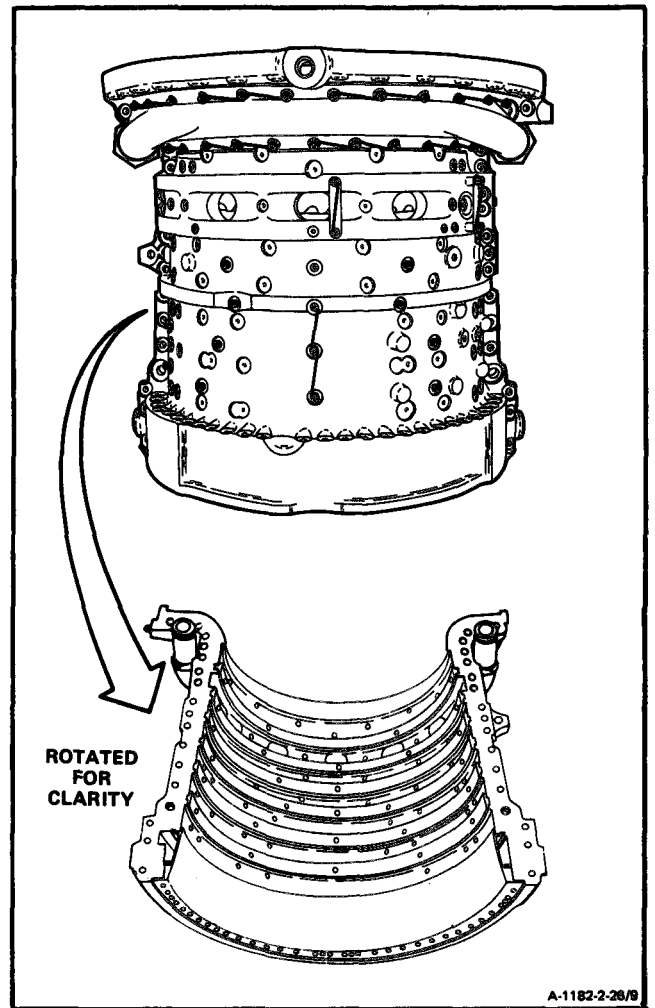

END OF TASK

INITIAL SETUP**Applicable Configurations:**

All

Tools:

Goggles
Compressed Air Source
Fiber Brush

Materials:

Dry Cleaning Solvent (E17)
Gloves (E20)

Personnel Required:

68B10 Aircraft Powerplant Repairer

Equipment Condition:

Compressor Housing Removed (Task 2-19
or 2-20)
Stator Vane Assemblies Removed (Task 2-26)

General Safety Instructions:**WARNING**

Dry cleaning solvent (E17) is flammable and toxic. It can irritate skin and cause burns, Use only in well-ventilated area, away from heat and open flame. In case of contact, immediately flush skin or eyes with water for at least 15 minutes. Get medical attention for eyes.

1. Wear gloves and immerse stator vane assemblies (1,2,3,4,5,6, and 7) in dry cleaning solvent (E17).
2. Remove contaminants by scrubbing stator vane assemblies with fiber brush.

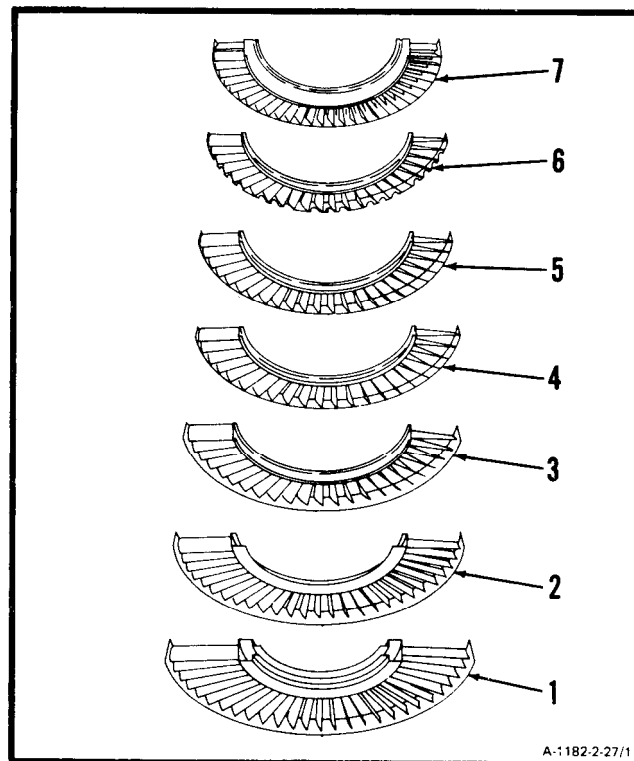
**GO TO NEXT PAGE**

WARNING

When using compressed air for cleaning, use approved protective equipment for eyes and face. Do not use more than **30 psig** air pressure. Do not direct air toward yourself or another person. Failure to comply could result in injury to eyes or skin. In case of injury, get medical attention.

3. Wear goggles and **blow dry stator vane assemblies** using clean, dry compressed air.

FOLLOW-ON MAINTENANCE:

Inspect Stator Vane Assemblies (Task 2-28).

END OF TASK

INITIAL SETUP**Applicable Configurations:**

All

Tools:Technical Inspection Tool Kit,
NSN 5180-00-323-5114**Materials:**

None

Personnel Required:

68B30 Aircraft Powerplant Inspector

Equipment Condition:

Off Engine Task

NOTE

The following procedure applies to both upper and lower stator vane halves.

1. Inspect stator vanes (1) as follows:**NOTE**

Stator vanes may be copper flashed. Copper flashed stator vanes may appear corroded or rusty. Do not reject stator vanes for this reason.

- a. There shall be no cracks. There shall be no damage with sharp edges.
- b. There shall be no nicks, burrs, pits and dents greater than 0.100 inch depth to 0.500 inch length.
- c. Airfoil damage (2) shall not be greater than 0.030 inch depth and 0.025 inch length.

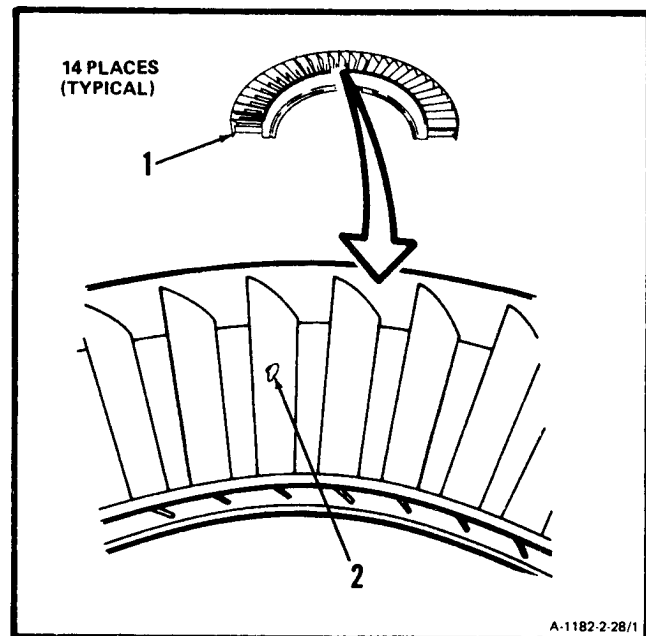
**GO TO NEXT PAGE**

2-28 INSPECT STATOR VANE ASSEMBLIES (Continued)

2-28

- d. Leading and trailing edge (3) damage shall not be greater than 0.100 inch depth or 0.500 inch length. The total length of all damage on either edge shall not exceed 40 percent of vane length.

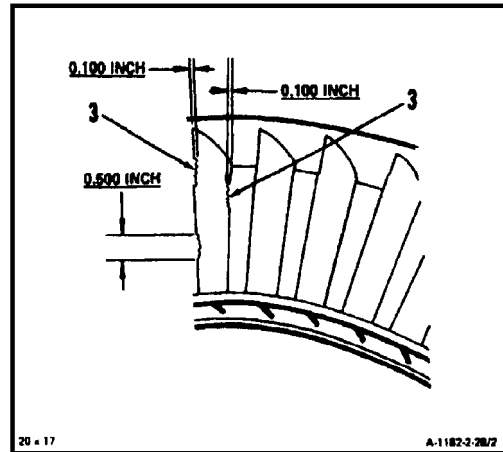

- e. Inspect for bent vanes (4).
- f. There shall be no cracks in the vane brazement areas (5) longer than 0.100 inch.
- g. Inspect lead seal (6).
 - (1) There shall be no nicks, scratches, voids, or pits (7) in lead seal (6) deeper than 0.010 inch or wider than 0.030 inch.
 - (2) Lead seal rub (8) up to 0.010 inch deep is acceptable. Loss of lead up to 0.250 inch per stator half and 0.500 inch per stator assembly is acceptable. Total loss of lead per compressor assembly shall not exceed 1.500 inch.
 - (3) There shall not be more than one of these defects (7 & 8) per inch and not less than 0.250 inch between any defects (7 & 8).
- h. Inspect outer shroud (9). There shall be no RTV residue.

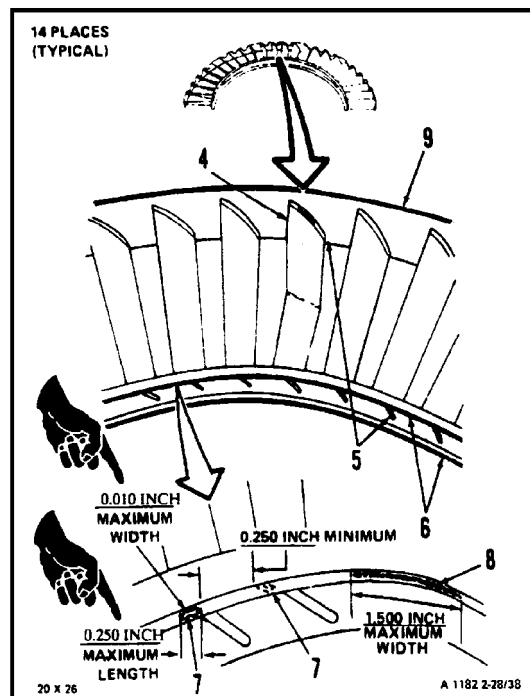

FOLLOW-ON MAINTENANCE

None

END OF TASK

2-29 REPAIR STATOR VANE ASSEMBLIES

2-29

INITIAL SETUP**Applicable Configurations:**

All

Tools:

Powerplant Mechanics Tool Kit,
NSN 5180-00-323-4944
Technical Inspection Tool Kit,
NSN 5180-00-323-5114

Materials/Parts:

Carborundum Stone (E 10)
Crocus Cloth (E15)
Fluorescent-Penetrant Materials (E73),
Appendix C

Personnel Required:

68B10 Aircraft Powerplant Repairer
68B30 Aircraft Powerplant Inspector

References:

TM 1-1500-335-23

Equipment Condition:

Off Engine Task

NOTE

This repair procedure applies to both top and bottom stator vanes.

1. **Repair bent vanes**, (1) by cold-straightening vanes (1) with duck-billed pliers. Use duckbilled pliers to firmly hold vane (1). Apply hand pressure and straighten vane (1).
2. **Perform fluorescent penetrant inspection of vanes** (1) Per paragraph 2-12.1.e, after straightening (Ref. TM 1-1500-335-23). There shall be no cracks in repaired area.

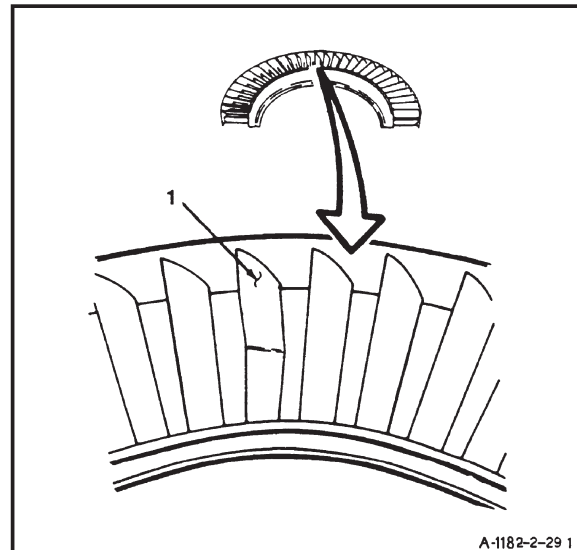

GO TO NEXT PAGE

2-29 REPAIR STATOR VANE ASSEMBLIES (Continued)

2-29

3. **Remove nicks, burrs, pits and dents on vanes (1), leading edge (2) and trailing edge (3).** Depth of repair shall not exceed 0.100 inch. Length of repair shall not exceed 0.500 inch.

- a. Blend all sharp edges using Carborundum stone (E10).
- b. Polish to smooth finish using crocus cloth (E15).

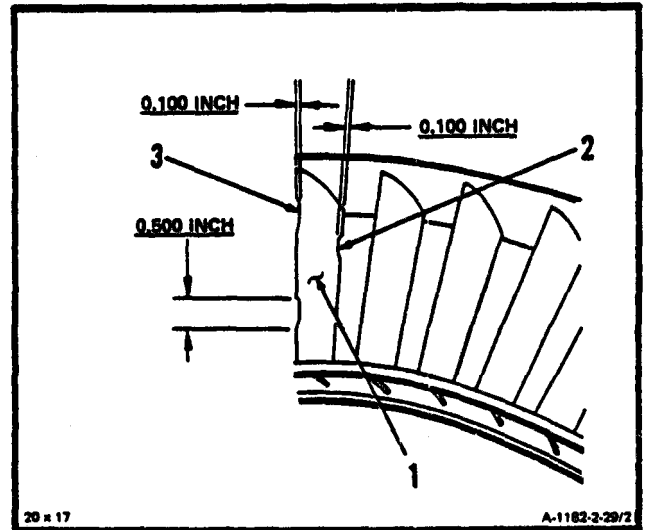

4. **Repair airfoil damage (4) on vane (1) as follows:**

- a. Blend all sharp edges using Carborundum stone (E10).
- b. Polish to smooth finish using crocus cloth (E15). Repair shall not be greater than 0.030 inch depth and 0.025 inch length.

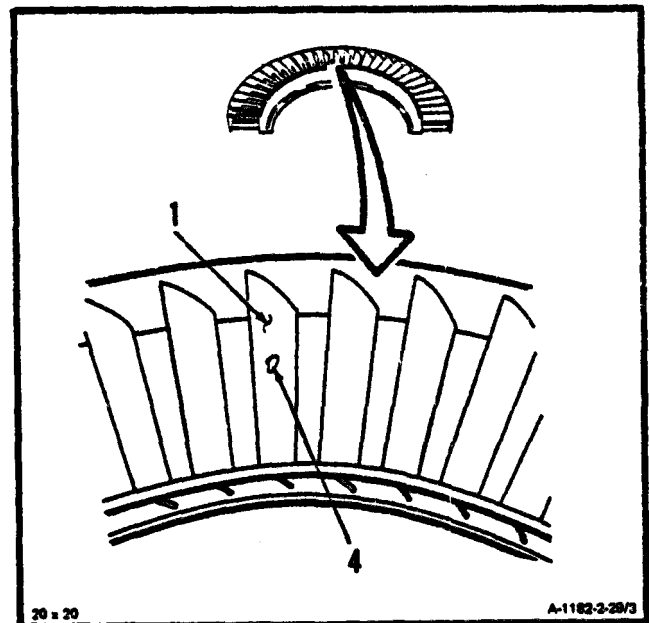

INSPECT

FOLLOW-ON MAINTENANCE:

None

END OF TASK

INITIAL SETUP

Applicable Configurations:

All

Tools:

- Powerplant Mechanic's Tool Kit,
NSN 5180-00-323-4944
- Technical Inspector Tool Kit,
NSN 518000-323-5114
- Locking Cup Punch (T21)
- Flat Hand File

Materials:

- Acid Swabbing Brush (E2)
- Dry Cleaning Solvent (E1 7)
- Gloves (E20)
- Lint-Free Cloth (E26)
- Non-lead Gear Marking Compound (E38.1)

Personnel Required:

- 68B10 Aircraft Powerplant Repairer
- 68B30 Aircraft Powerplant Inspector

References:

- Task 2-19 Task 2-25
- Task 2-20 Task 2-26
- Task 2-24 Task 2-27

General Safety Instructions:

WARNING

Dry cleaning solvent (E17) is flammable and toxic. It can irritate skin and cause burns. Use only in well-ventilated area, away from heat and open flame. In case of contact, immediately flush skin or eyes with water for at least **15 minutes**. Get medical attention for eyes.

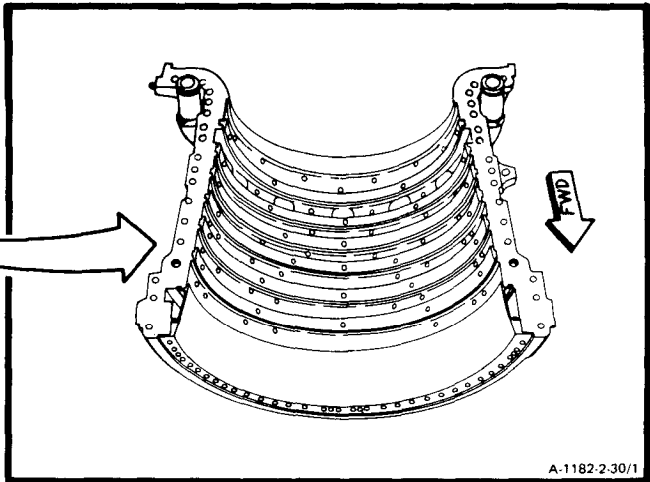
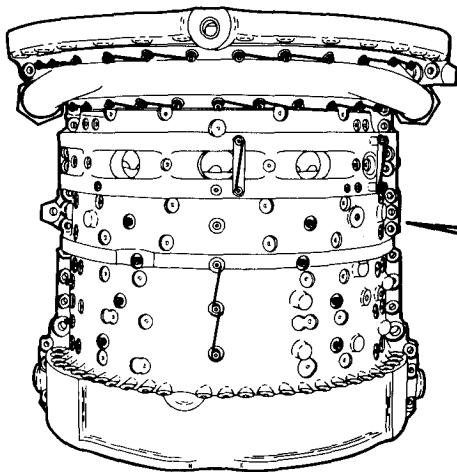

42 x 15

A-1182-2-30/1

GO TO NEXT PAGE

NOTE

Stator vane assembly halves which meet serviceable limits may be matched with other serviceable vane assembly halves. Rematched halves shall meet all assembly requirements. Rematched halves should have about the same amount of erosion or FOD.

NOTE

Procedural for installing upper and lower compressor housing stator vane assemblies are the same. Instructions for installing lower compressor housing stator vanes are given.

1. Install one-half of seventh stage stator vane (1) into compressor housing half (2) as follows:
 - a. Install three washers (3) and three bolts (4) in bolt locations (5). Finger tighten bolts (4).
 - b. Install six washers (6) and six bolts (7) in bolt locations (8). Finger tighten bolts (7).

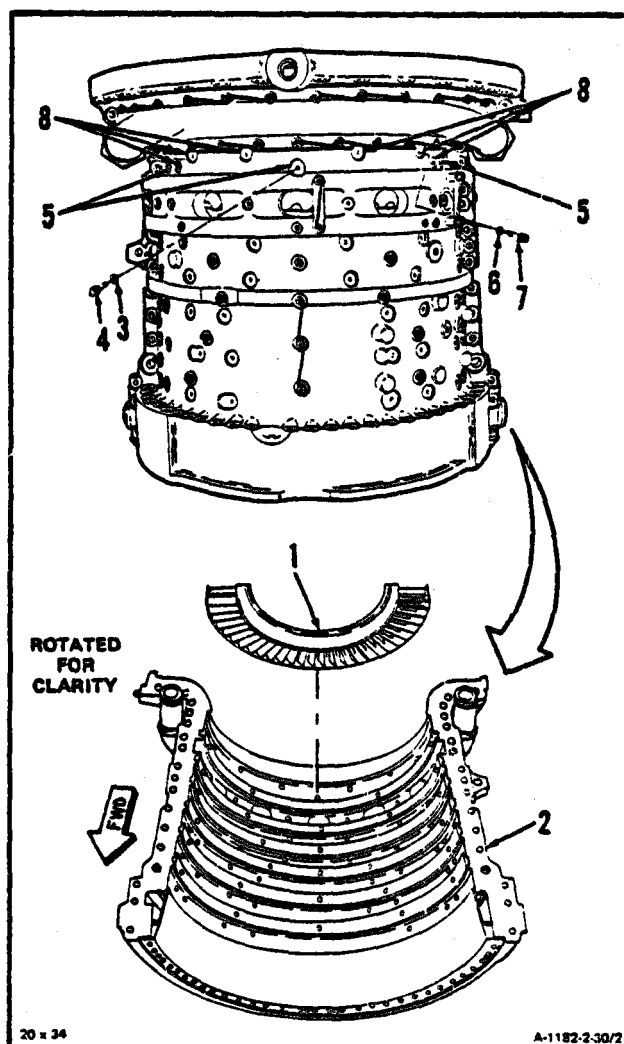

GO TO NEXT PAGE

c. Torque two bolts (7) to 45 inch-pounds.

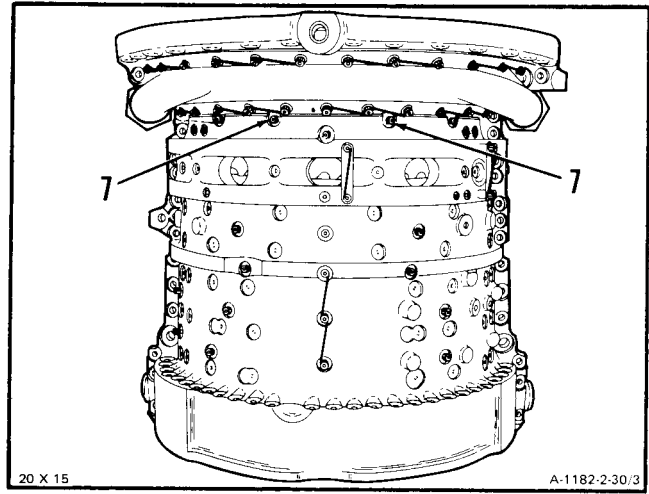

d. Torque two bolts (6) to 22 inch-pounds.

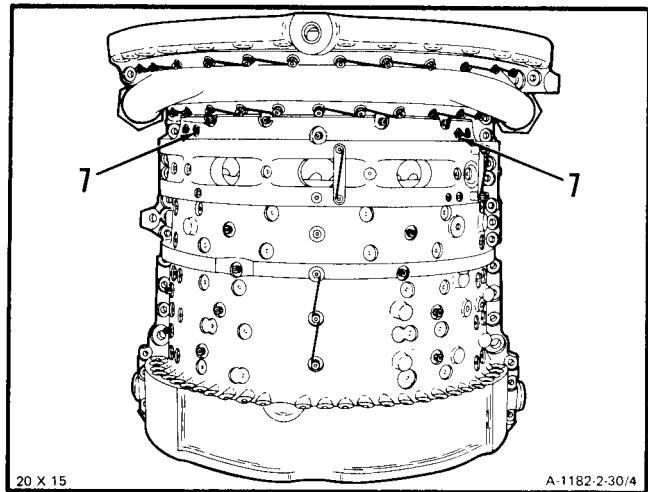

e. Torque two bolts (4) and two bolts (7) to 22 inch-pounds.

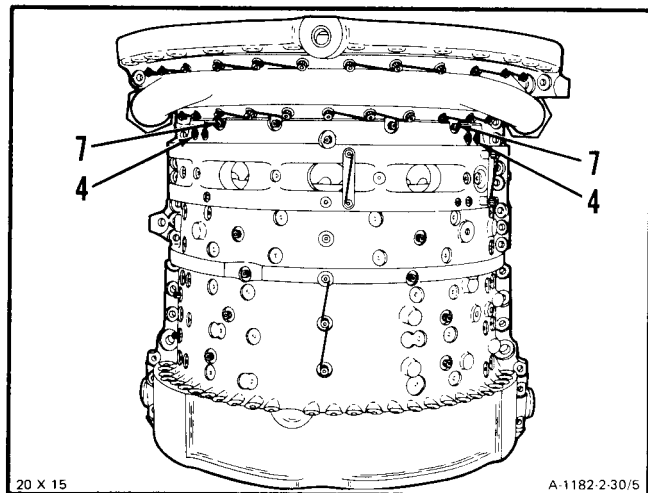

GO TO NEXT PAGE

f. Torque bolt (4) to 65 inch-pounds.

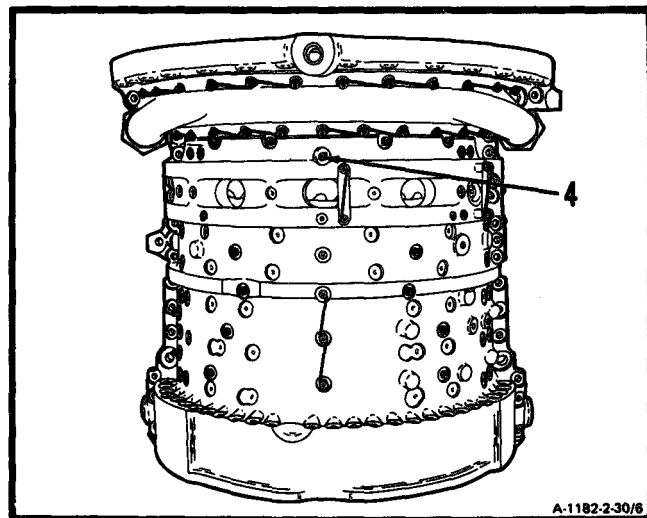

- g. Check ends of bolts (4 and 7). Bolt ends shall be flush or not more than 0.035 inch below surface of stator. If necessary, add washers under bolt heads. There must be at least one washer under each bolt had.
- h. Calculate gap between stator vane shrouds as outlined in step 8.
- i. Lockwire bolts (4 and 7). Use lockwire (E29).

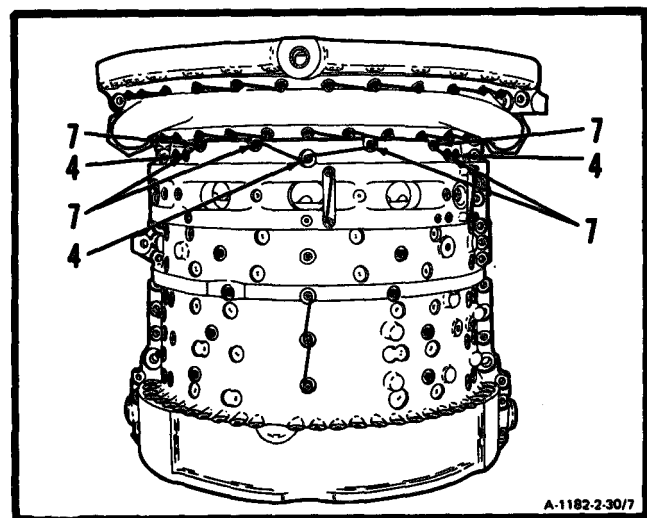

INSPECT

GO TO NEXT PAGE

2. Install one-half of sixth stage stator vane (9) into compressor housing half (2).

Install six locking cups (10) and six screws (11) in screw holes locations (12). Finger tighten screws (11).

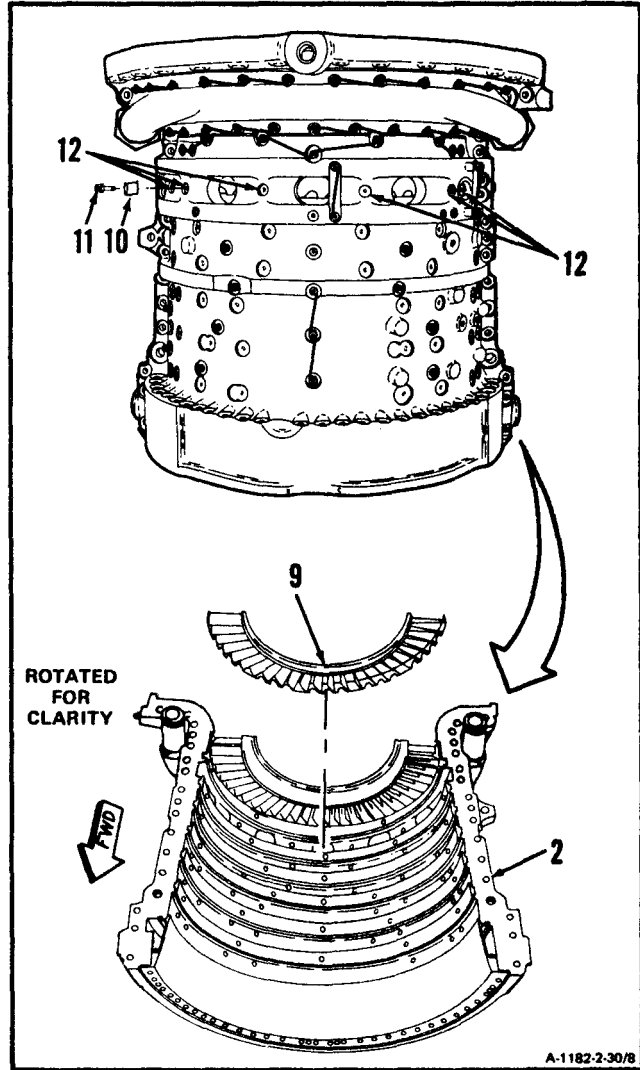

GO TO NEXT PAGE

2-30 INSTALL STATOR VANE ASSEMBLIES (Continued)

2-30

b. Torque two screws(11) to 45 inch-pound

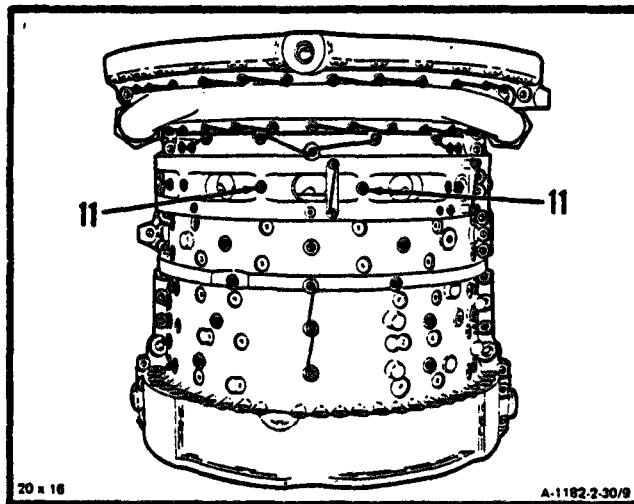

c. Torque four screws (11) to 15 inch-pounds.

d. Check ends of screws (11). Screw ends shall be flush or not more than 0.035 inch below surface of stator. If necessary add washers

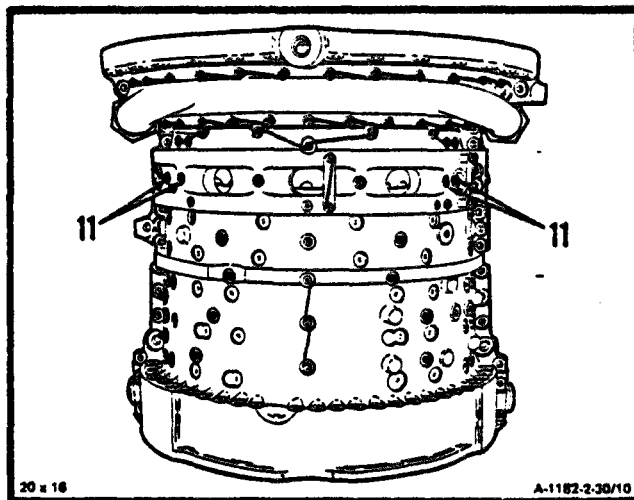

GO TO NEXT PAGE

- e. Calculate gap between stator vane shrouds as outlined in step 8.
- f. Lock six screws (11) by deforming rim of six locking cups (10). Deform rim of locking cups (10) into two screw slots and compressor housing on opposite sides. Use locking cup punch (T21).

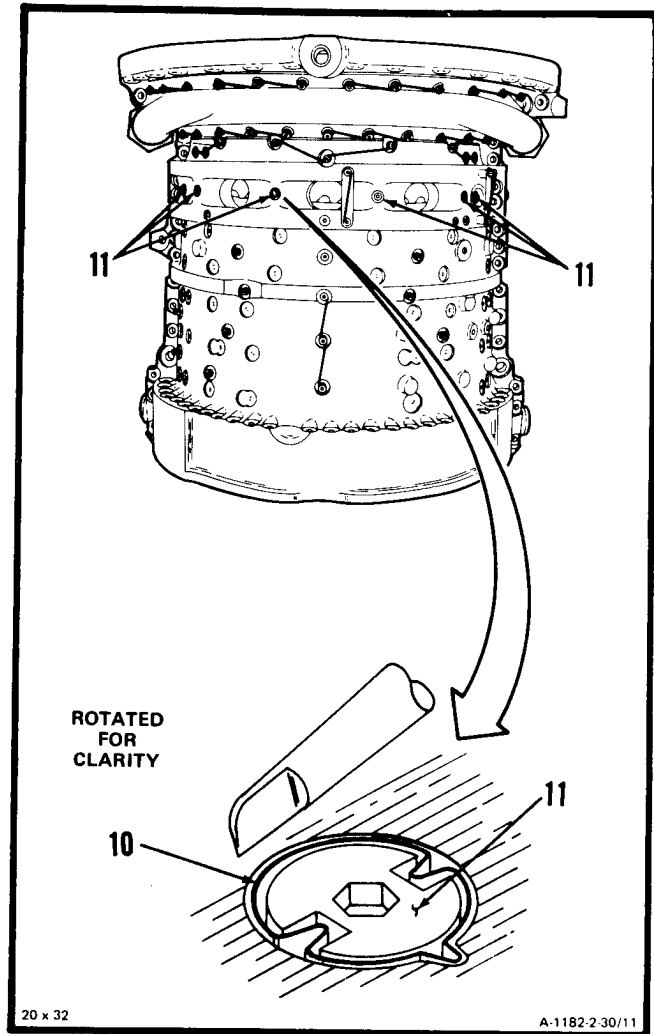

INSPECT

GO TO NEXTPAGE

2-30 INSTALL STATOR VANE ASSEMBLIES (Continued)

2-30

CAUTION

Make certain that fifth stage stator vane is installed with leading edge of vanes facing forward. If vane assembly is installed wrong, the outer shroud will protrude into airflow path. This may cause unusual stresses on compressor blades which could result in blade failure.

3. Install one-half of fifth stage stator vane (12) into compressor housing half (2).
 - a. Make certain that leading edge (13) of vane faces forward
 - b. Install six washers (14) and six bolts (15) in bolt hole locations (16). Finger tighten bolts (15).

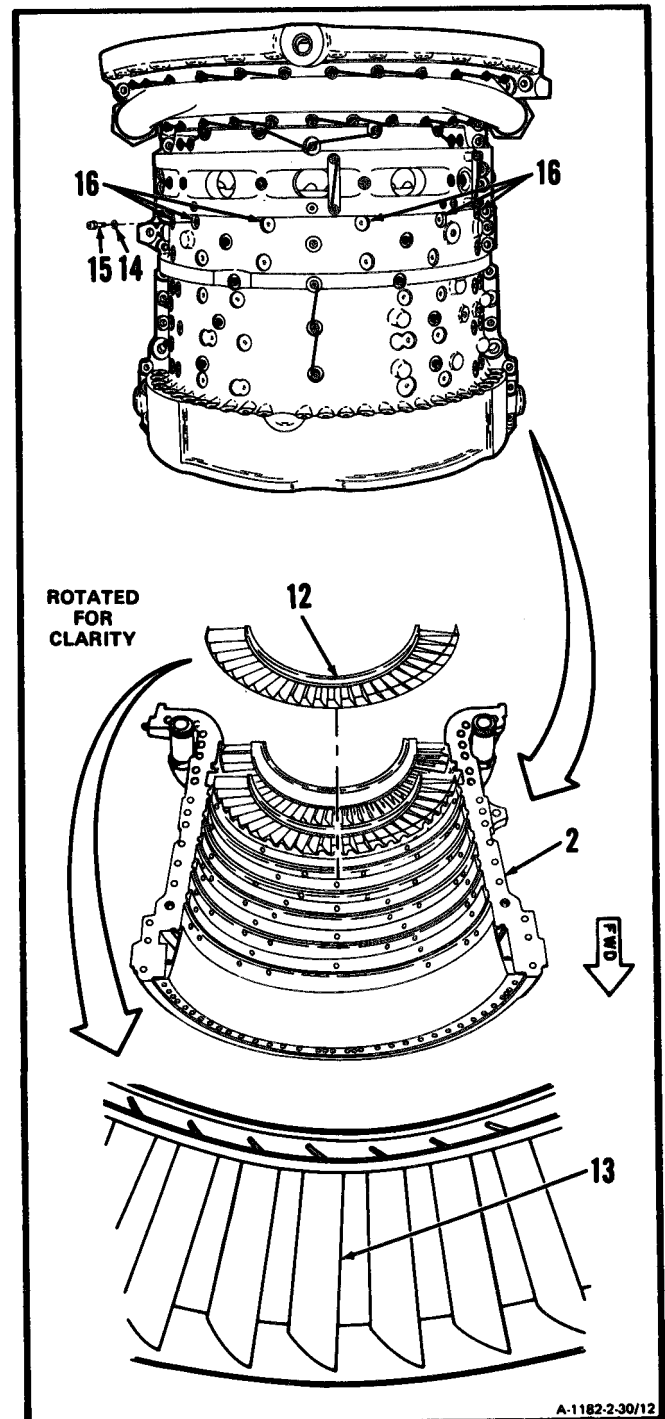

GO TO NEXT PAGE

c. Torque two bolts (15) to 45 inch-pounds.

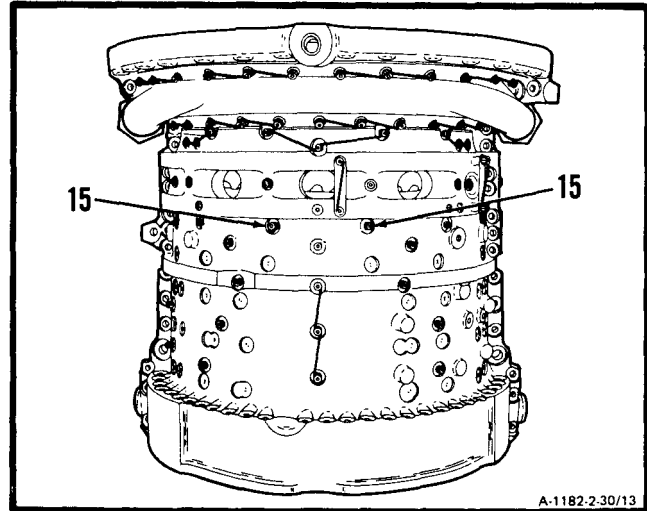

d. Torque four bolts (15) to 15 inch-pounds.

e. Check ends of bolts (15). Bolt ends shall be flush, or not more than 0.035 inch below surface of stator. If necessary add washers under bolt heads. There must be at least one washer under each bolt head.

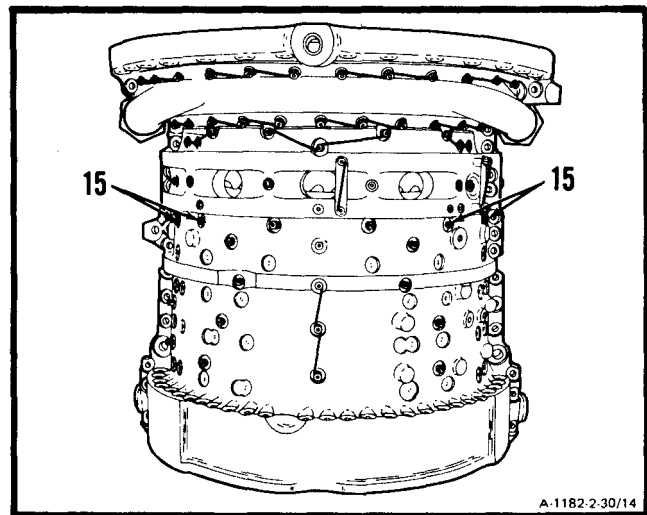

f. Calculate gap between stator vane shrouds as outlined in step 8.

GO TO NEXT PAGE

CAUTION

Make certain that fourth stage vane is installed with leading edge of vanes facing forward. If vane assembly is installed wrong, the outer shroud will protrude into airflow path. This may cause unusual stresses on compressor blades which could result in blade failure.

4. Install one-half of fourth stage stator vane (17) into compressor housing half (2).
 - a. Make certain that leading edge (18) of vane faces forward.
 - b. Install six washers (19) and six bolts (20) in bolt hole locations (21). Finger tighten bolts (20).

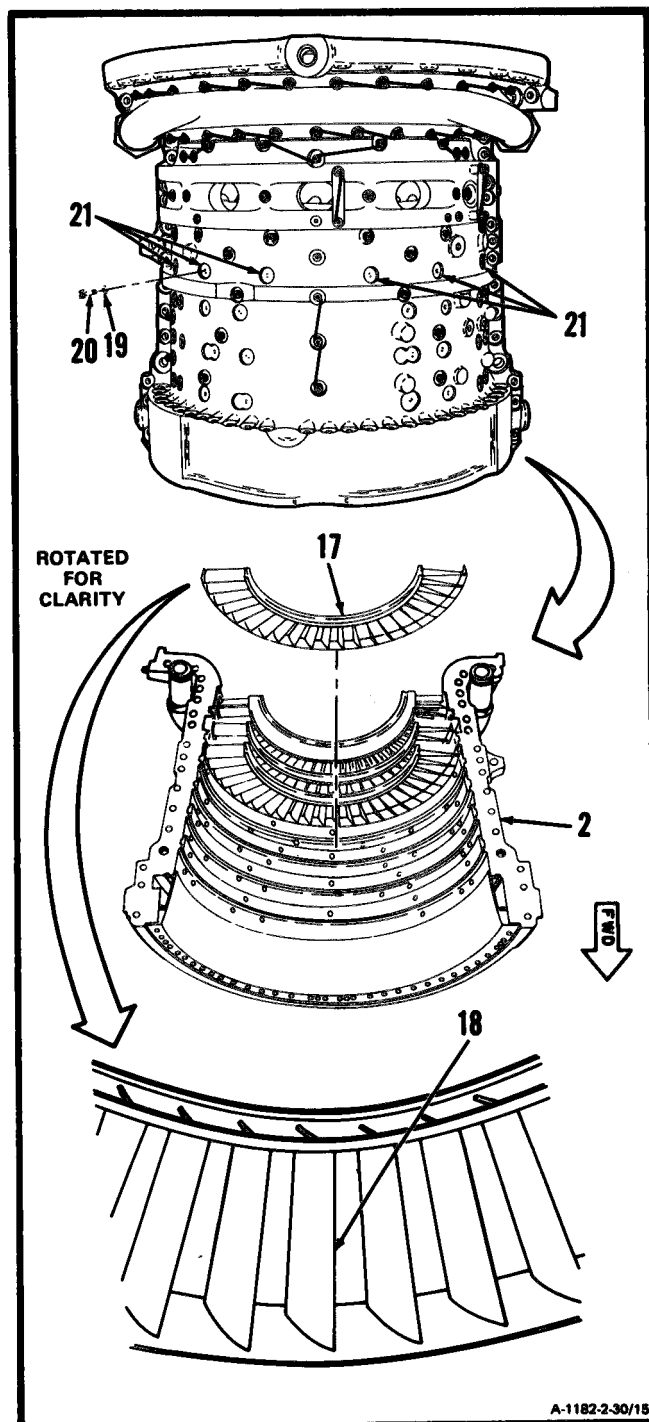

GO TO NEXT PAGE

c. Torque two bolts (20) to 45 inch-pounds.

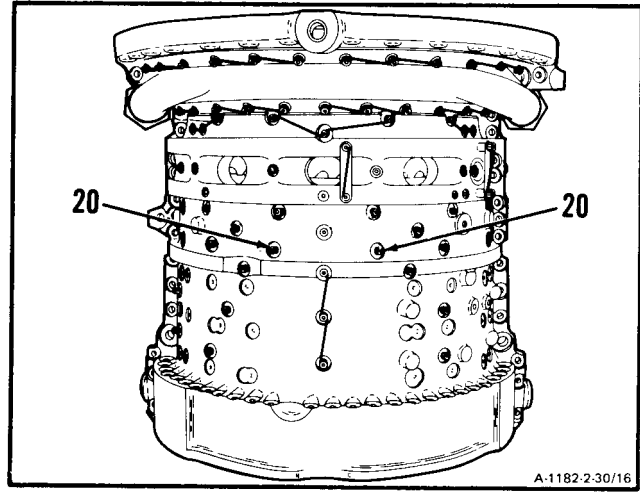

d. Torque four bolts (20) to 15 inch-pounds.

e. Check ends of bolts (20). Bolt ends shall be flush, or not more than 0.035 inch below surface of stator. If necessary add washers under bolt heads. There must be at least one washer under each bolt head.

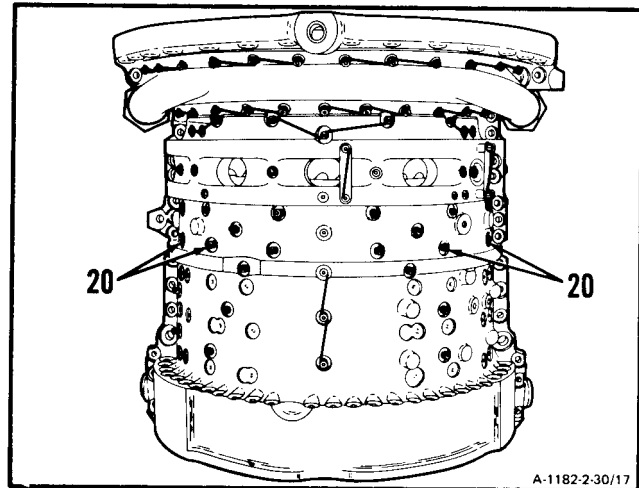

f. Calculate gap between stator vane shrouds as outlined in step 8.

g. Lockwire bolts (15) and (20). Use lockwire (E29).

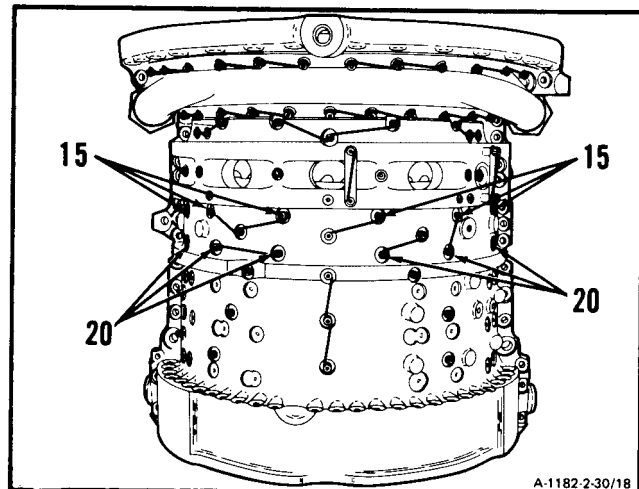

INSPECT

GO TO NEXT PAGE

5. Install one-half of third stage stator vane (22) into compressor housing half (2).

- a. Install eight washers (23) and eight bolts (24) in bolt hole locations (25). Finger tighten bolts (24).

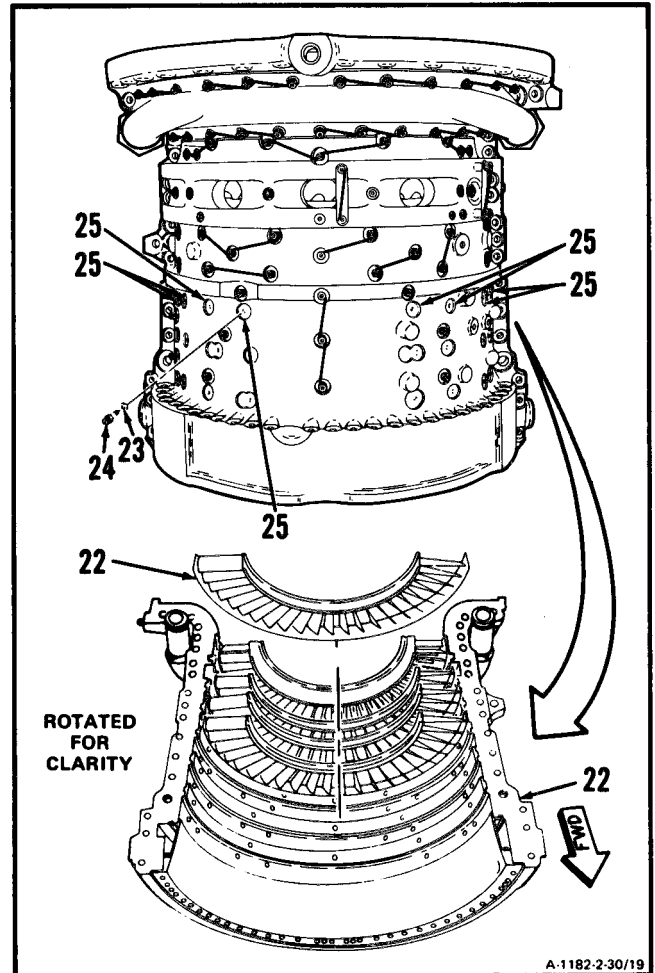

- b. Torque two bolts (24) to 45 inch-pounds.

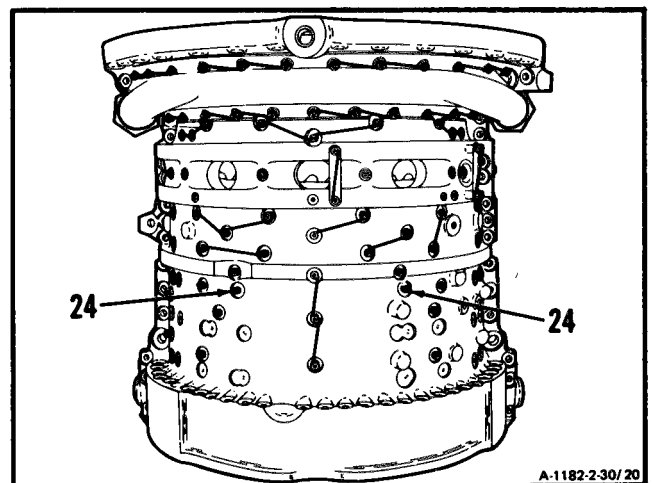

GO TO NEXT PAGE

- c. Torque six bolts (24) to 15 inch-pounds.
- d. Check ends of bolts (24), Bolts ends shall be flush, or not more than 0.035 inch below surface of stator. If necessary add washers under bolt heads. There must be at least one washer under each bolt head.
- e. Calculate gap between stator vane shrouds as outlined in step 8.
- f. Lockwire bolts (24). Use lockwire (E29).

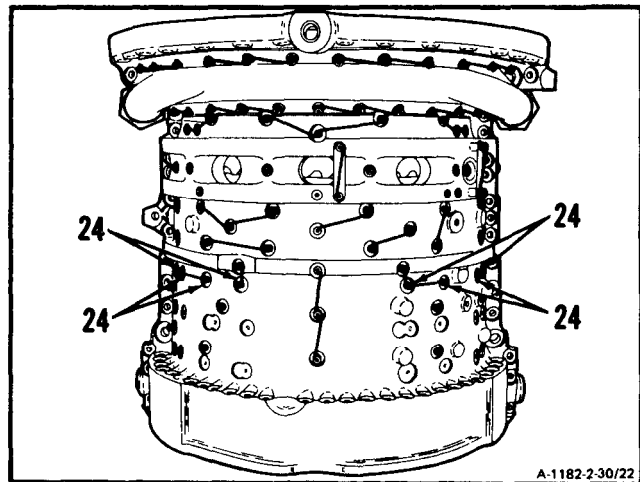
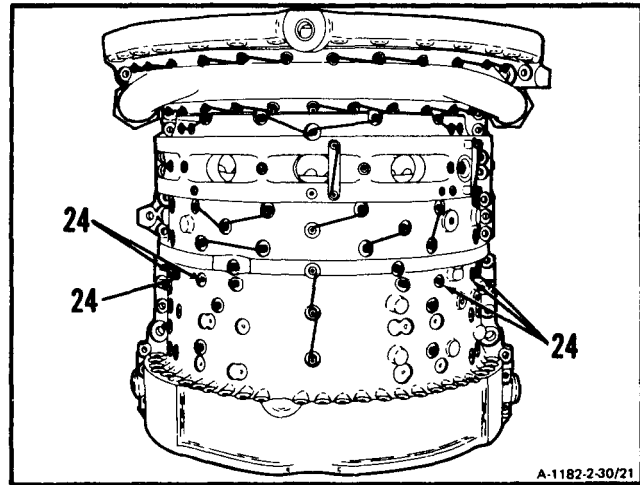

INSPECT

GO TO NEXT PAGE

2-30 INSTALL STATOR VANE ASSEMBLIES (Continued)

2-30

6. Install one-half of second stage stator vane (26) into compressor housing half (2).

- a. Install eight washers (27) and eight bolts (28) in bolt hole locations (29). Finger tighten bolts (28).

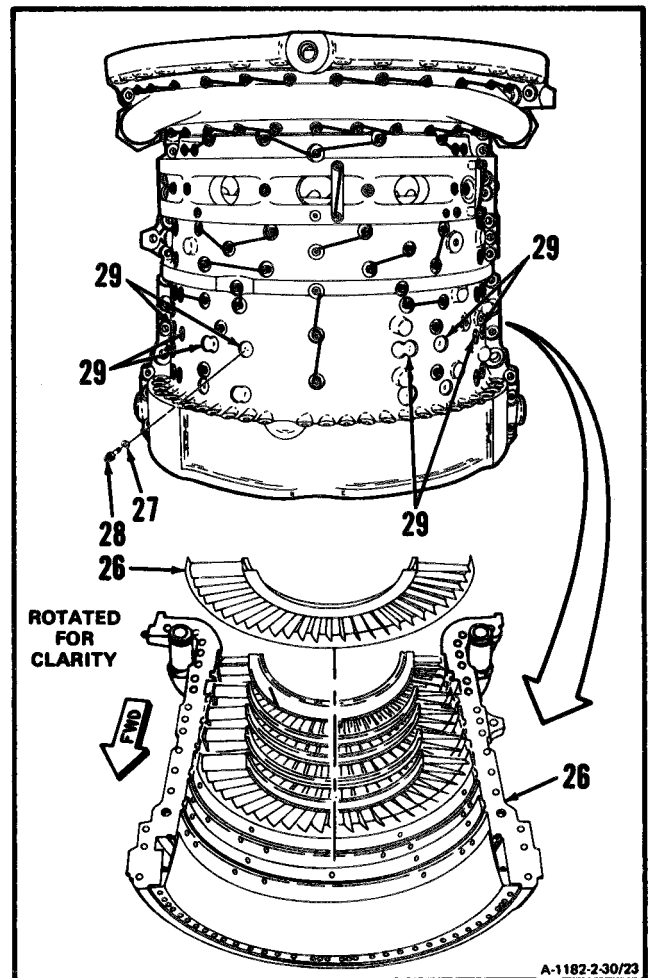

- b. Torque two bolts (28) to 45 inch-pounds.

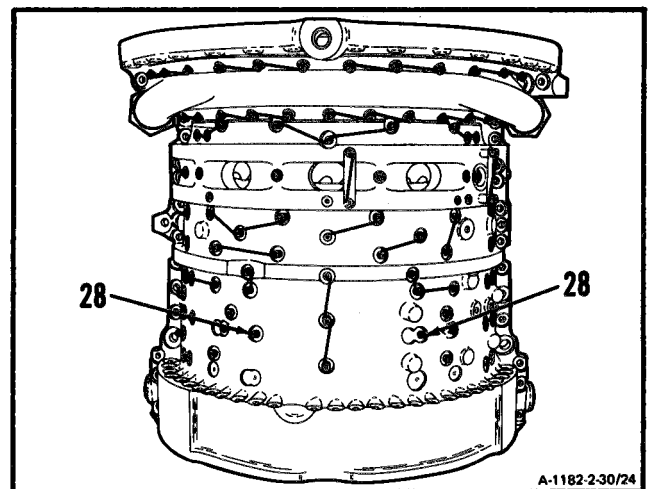
**GO TO NEXT PAGE**

c. Torque six bolts (28) to 15 inch-pounds.

d. Check ends of bolts (28). Bolt ends shall be flush, or not more than 0.035 inch below surface of stator. If necessary add washers under bolt heads. There must be at least one washer under each bolt head.

e. Calculate gap between stator vane shrouds as outlined in step 8.

f. Lockwire bolts (28). Use lockwire (E29).

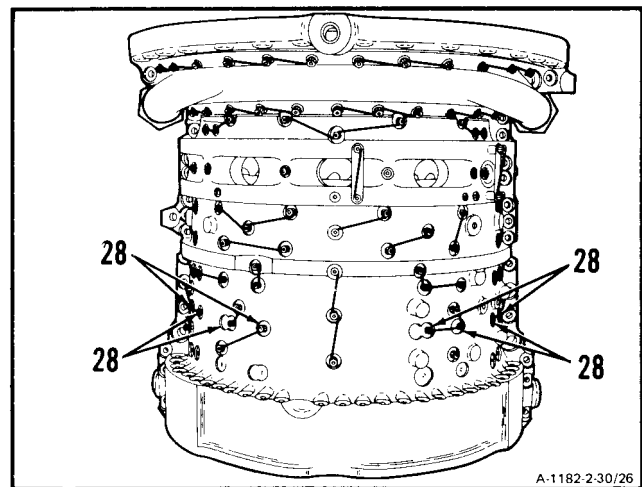
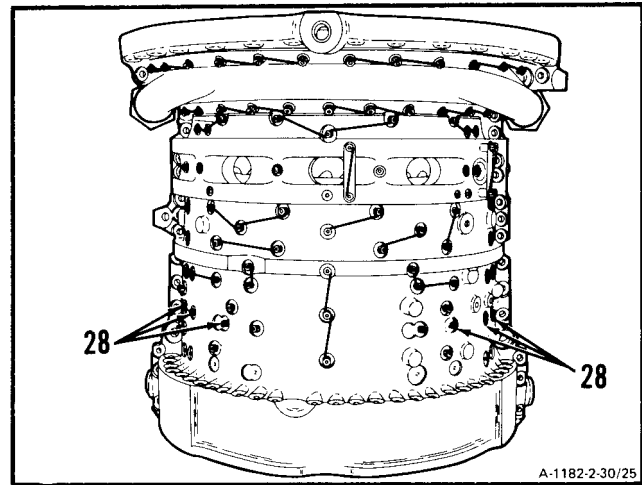

INSPECT

GO TO NEXT PAGE

NOTE

The following step is for P/N 2-101-790-01 only.
For P/N 2-101-790-47 and P/N 2-101-790R46
Ref. to Task 2-30.1.

7. **Install one-half of first stage stator vane (30) into each half of compressor housing (2).**
 - a. Install eight washers (31) and eight bolts (32) in bolt hole locations (33). Finger tighten bolts (32).

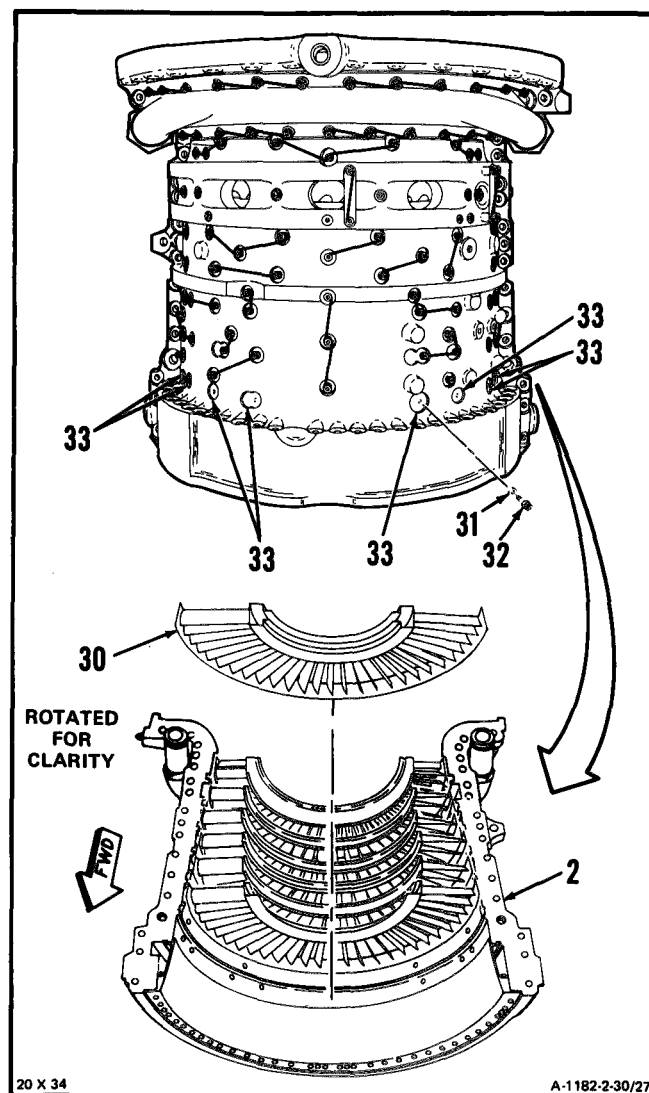

GO TO NEXT PAGE

- b. Starting with center bolts (32) torque bolts (32) first to 45 inch-pounds. Loosen all bolts and retorque to 15 inch-pounds using the same order.
- c. Check ends of bolts (32). Bolt ends shall be flush, or not more than 0.035 inch below surface of stator. If necessary add washers under bolt heads. There must be at least one washer under each bolt head.
- d. Calculate gap between stator vane shrouds as outlined in step 8.
- e. Lockwire bolts (32). Use lockwire (E29).

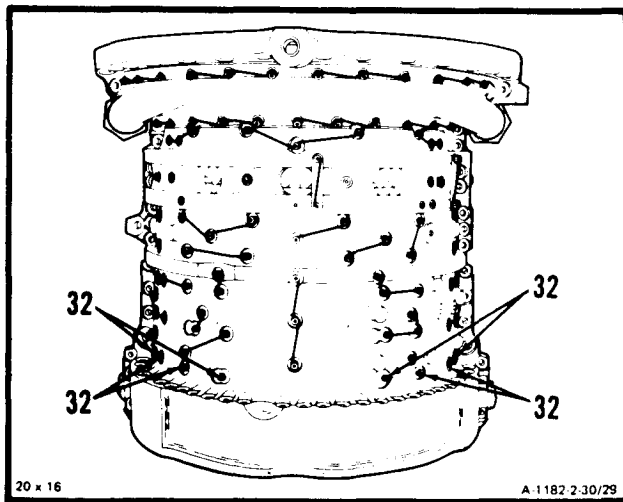
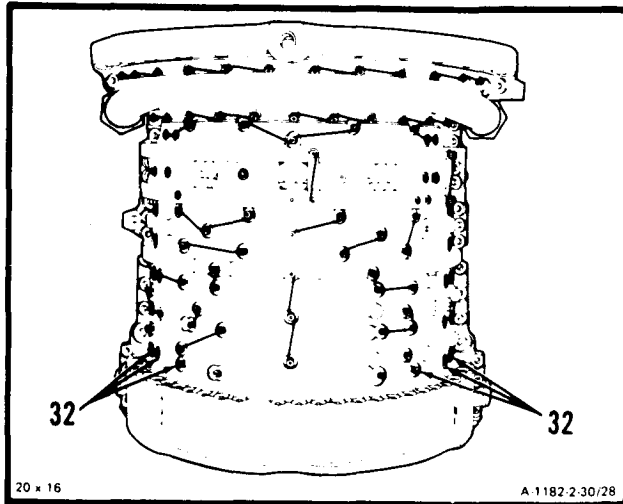

INSPECT

GO TO NEXT PAGE

2-30 INSTALL STATOR VANE ASSEMBLIES (Continued)

2-30

NOTE

The following procedure applies to the first thru seventh stage stator vane assemblies. First stage stator vane assembly is shown.

8. **Inspect for clearance between stator vane shrouds** as follows:
 - a. Apply non-lead gear marking compound (E38.1) to both ends (34) of stator vane shroud (35) on installed compressor housing half (36). Use acid swabbing brush (E2).

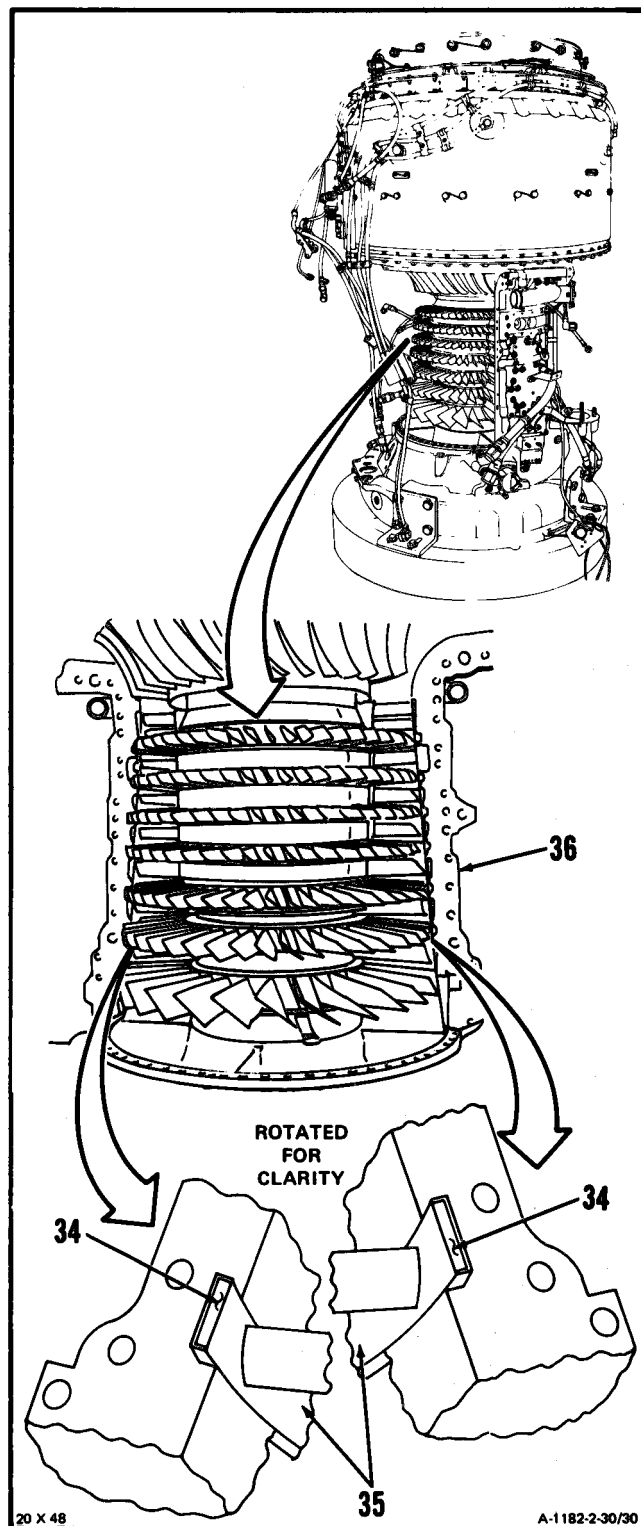
**GO TO NEXT PAGE**

- b. Apply non-lead gear marking compound (E38.1) to both ends (37) of stator vane shroud (38) on removed compressor housing half (39). Use acid swabbing brush (E2).
- c. **Temporarily install removed compressor housing half** (Ref. Task 2-24, steps 1. thru 3. or Task 2-25, steps 1. thru 3.).
- d. **Remove temporarily installed compressor housing half** (Ref. Task 2-19, steps 29. thru 32. and 38. or Task 2-20, steps 35. thru 38. and 48.).
- e. Inspect both ends (37) of stator vane shroud (38) of removed compressor housing half (39). There shall be no non-lead marking compound.
- f. If no non-lead gear marking compound is visible, clearance is acceptable.
- g. Wear gloves (E20). Use dry cleaning solvent (E17) and brush, clean off all non-lead marking compound. Wipe dry using lint-free cloth (E26).
- h. If non-lead gear marking compound is visible, proceed as follows:
 - (1) Loosen stator vane mounting bolts, shift stator vane and retorque mounting bolts (Refer to steps 1 thru 7).
 - (2) Repeat steps 8.a. thru 8.e.
 - (3) If non-lead gear marking compound is still visible, proceed as follows:

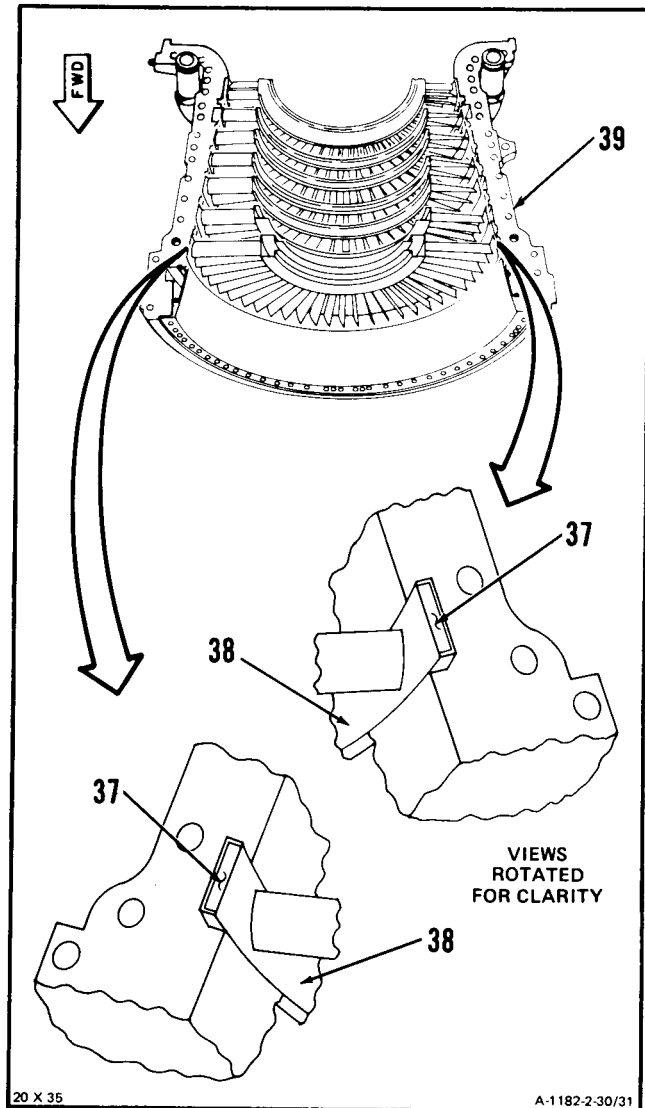

GO TO NEXT PAGE

2-30 INSTALL STATOR VANE ASSEMBLIES (Continued)

2-30

- (a) **Remove stator vane assemblies.**
(Ref. Task 2-26).
- (b) **File shroud ends (37).** Use flat hand file.
- (c) **Clean stator vane assemblies.**
(Ref. Task 2-27).

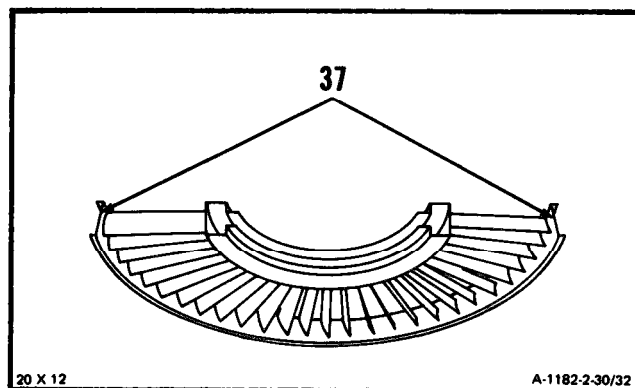
**INSPECT**

- (d) **Install stator vane assemblies**
(steps 1 thru 7).
- (e) **Repeat steps 8a. thru 8.e.**
- (f) If non-lead making compound is still visible, repeat step 8.h., (3), (a) thru (f).

GO TO NEXT PAGE

FOLLOW-ON MAINTENANCE:

Install Upper Compressor Housing (Task 2-24)
 or Lower Compressor Housing (Task 2-25).

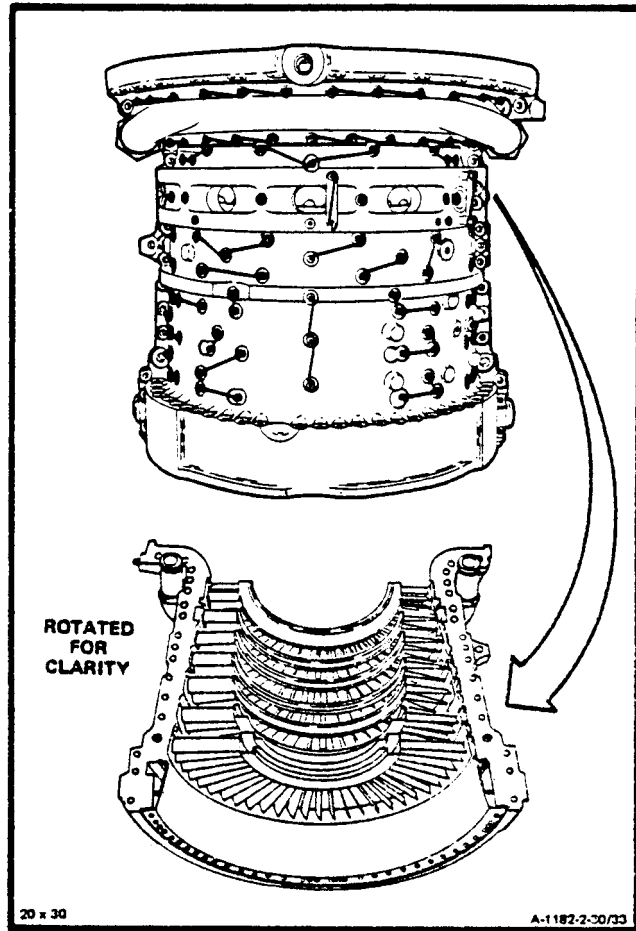

END OF TASK

2-254

2-30.1 INSTALL RTV IN FIRST STAGE STATOR VANE ASSEMBLY

2-30.1

INITIAL SETUP

Applicable Configurations:

All

Tools:

Powerplant Mechanics Tool Kit,
NSN 5180-00-323-4944
Technical Inspection Tool Kit,
NSN 5180-00-323-5114
Goggles
Compressed Air Source
RTV Application Kit (T38.1)
RTV Masking Kit, First Stage
Stator (T36.1)
Tongue Depressor

Materials/Parts:

Acetone (E1)
Acid Swabbing Brush (E2)
Dry Cleaning Solvent (E17)
Mold Release Compound (E19.1)
Gloves (E20)
Lint-Free Cloth (E26)
Lockwire (E29)
Masking Tape (E54)
Non-Lead Gear Marking Compound (E38.1)

Personnel Required:

68B10 Aircraft Powerplant Repairer
68B30 Aircraft Powerplant Inspector

References:

Task 2-19 Task 2-26
Task 2-20 Task 2-27
Task 2-24 Task 2-30
Task 2-25

General Safety Instructions:**WARNING**

Dry cleaning solvent (E17) is flammable and toxic. It can irritate skin and cause burns. Use only in well-ventilated area, away from heat and open flame. In case of contact, immediately flush skin or eyes with water for at least **15 minutes**. Get medical attention for eyes.

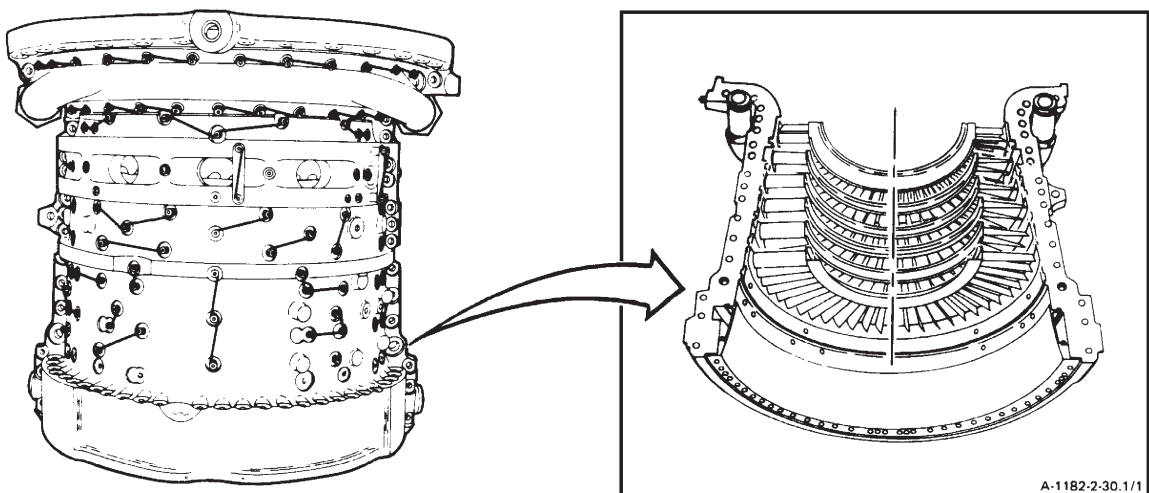
**END OF TASK**

NOTE

This task is for first stage stator assemblies P/N 2-101-790-47 and P/N 2-101-790R46.

NOTE

Procedure for installing upper and lower first stage stator assembly are the same. Instructions for installing lower compressor housing first stage stator vane are given.

1. Inject RTV in first stage stator vane assembly (1) as follows:

WARNING

Acetone (E1) is flammable and toxic. It can irritate skin and cause burns. Use only in well-ventilated area, away from heat and open flame. In case of contact, immediately flush skin or eyes with water for at least 15 minutes. Get medical attention for eyes.

- a. Wear gloves (E20) and using acetone (E1) and acid swabbing brush (E2) and lint-free cloth (E26) clean first stage stator mounting surface (2) of compressor housing half (3).

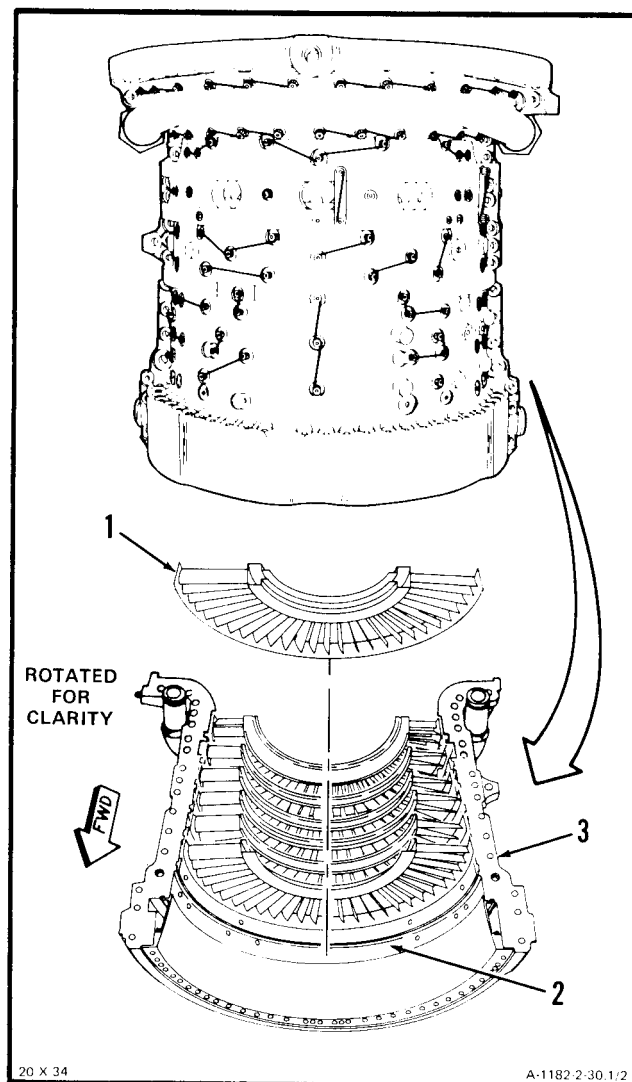

GO TO NEXT PAGE

2-30.1 INSTALL RTV IN FIRST STAGE STATOR VANE ASSEMBLY (Continued)

2-30.1

WARNING

When using compressed air for cleaning, use approved protective equipment for eyes and face. Do not use more than 30 psig air pressure. Do not direct air toward yourself or another person. Failure to comply could result in injury to eyes or skin. In case of injury, get medical attention.

- b. Wear goggles. Blow dry first stage stator mounting surface (2) using dean, dry compressed air.
- c. Mask compressor housing half (3) using one inch wide masking tape (E54) (4) leaving first stage stator vane assembly mounting surface (2) unmasked.

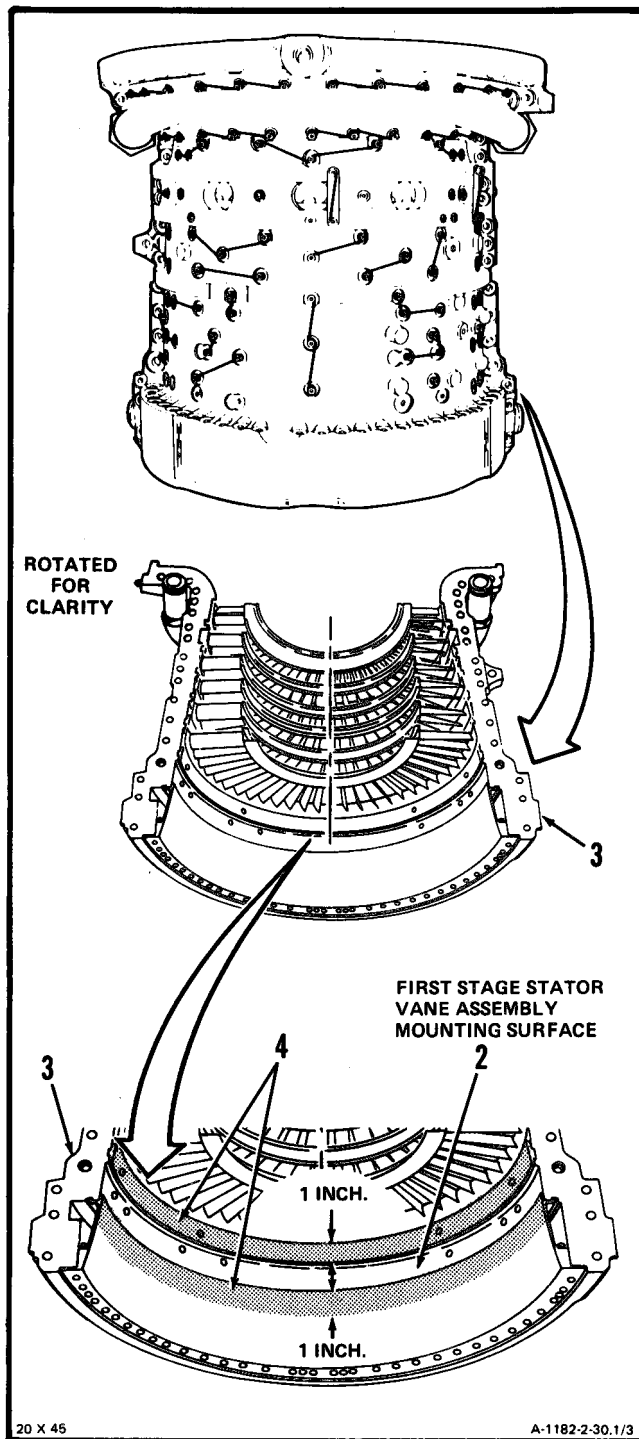

GO TO NEXT PAGE

NOTE

In following step take care not to overspray onto masked areas.

d. **Apply a thin, even film of dry film lubricant (E19.1)** mold resistant fluorocarbon to first stage stator vane assembly mounting surface (2) of compressor housing half (3).

e. **Remove masking tape (4).**

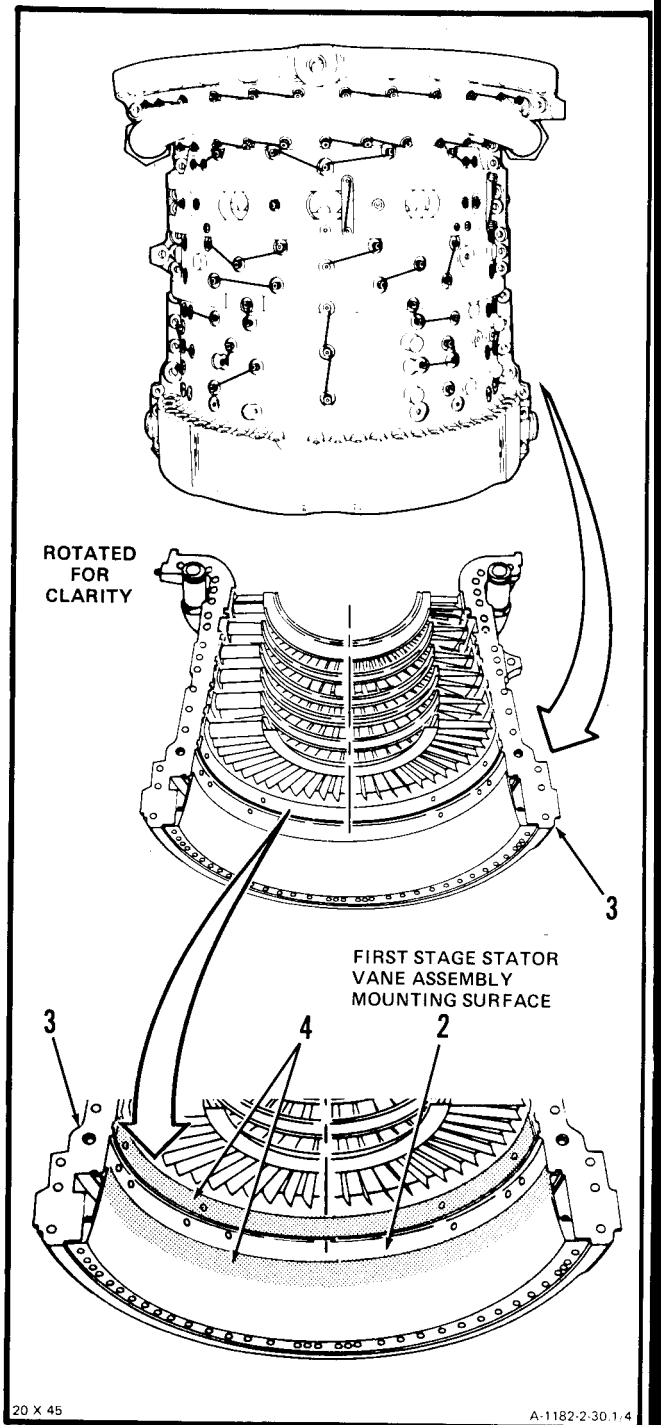

GO TO NEXT PAGE

2-30.1 INSTALL RTV IN FIRST STAGE STATOR VANE ASSEMBLY (Continued)

2-30.1

2. Install first stage stator vane (1) into compressor housing half (3).

- a. Install eight washers (5) and eight bolts (6) in bolt hole locations (7). Finger tighten bolts (6).

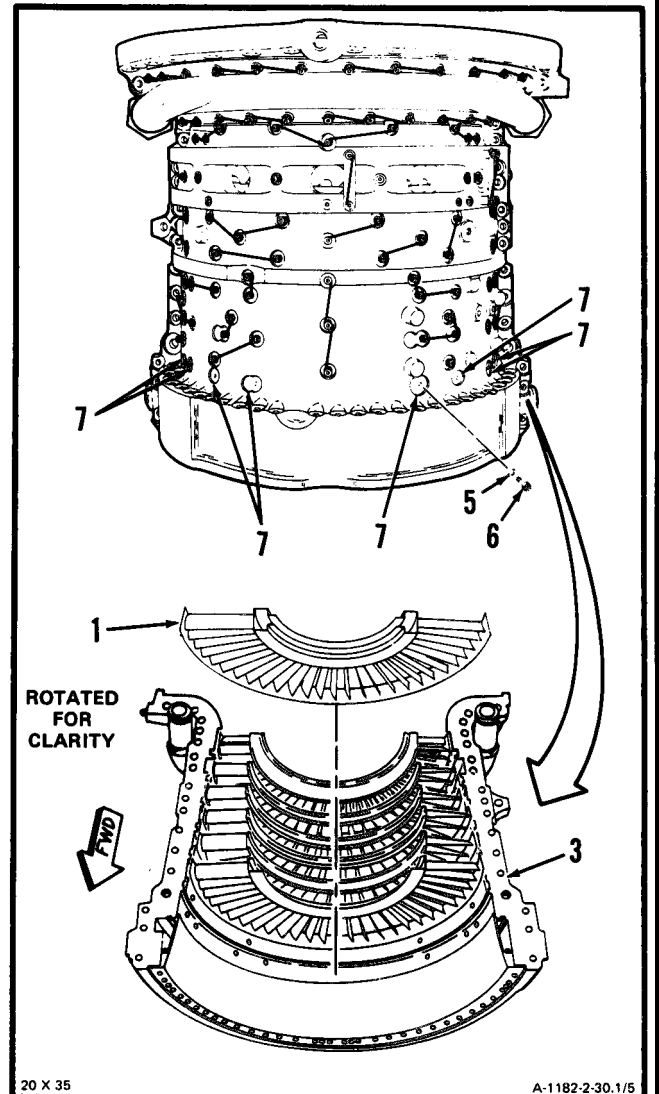
**GO TO NEXT PAGE**

- b. Starting with center bolts (6) in torque bolts (6) first to 45 inch-pounds. Loosen all bolts and retorque to 15 inch-pounds using the same order.
- c. Check ends of bolts (6). Bolt ends shall be flush, or not more than 0.035 inch below surface of stator. If necessary, add washers under bolt heads. There must be at least one washer under each bolt head.
- d. Calculate gap between stator vane shrouds as outlined in step 3.
- e. Lockwire bolts (6). Use lockwire (E29).

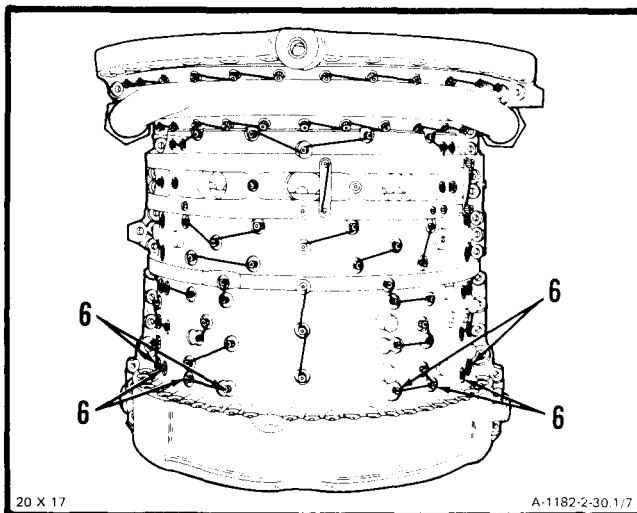
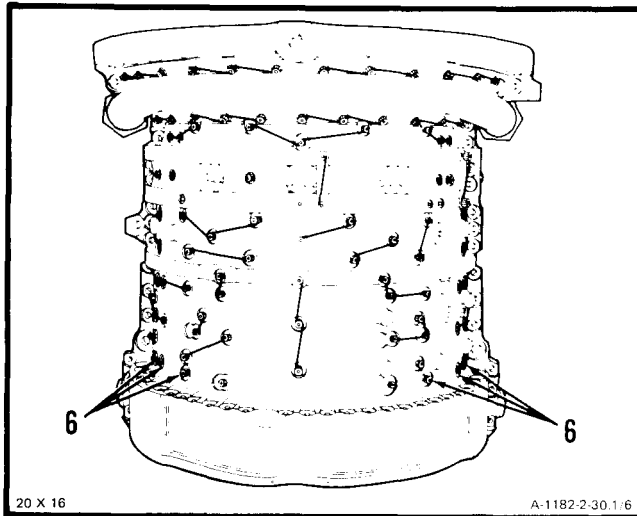

GO TO NEXT PAGE

2-30.1 INSTALL RTV IN FIRST STAGE STATOR VANE ASSEMBLY (Continued)

2-30.1

3. Inspect for clearance between stator vane shrouds as follows:

- a. Apply non-lead gear marking compound (E38.1) to both ends (8) of stator vane shroud (9) on installed compressor housing half (10). Use acid swabbing brush (E2).

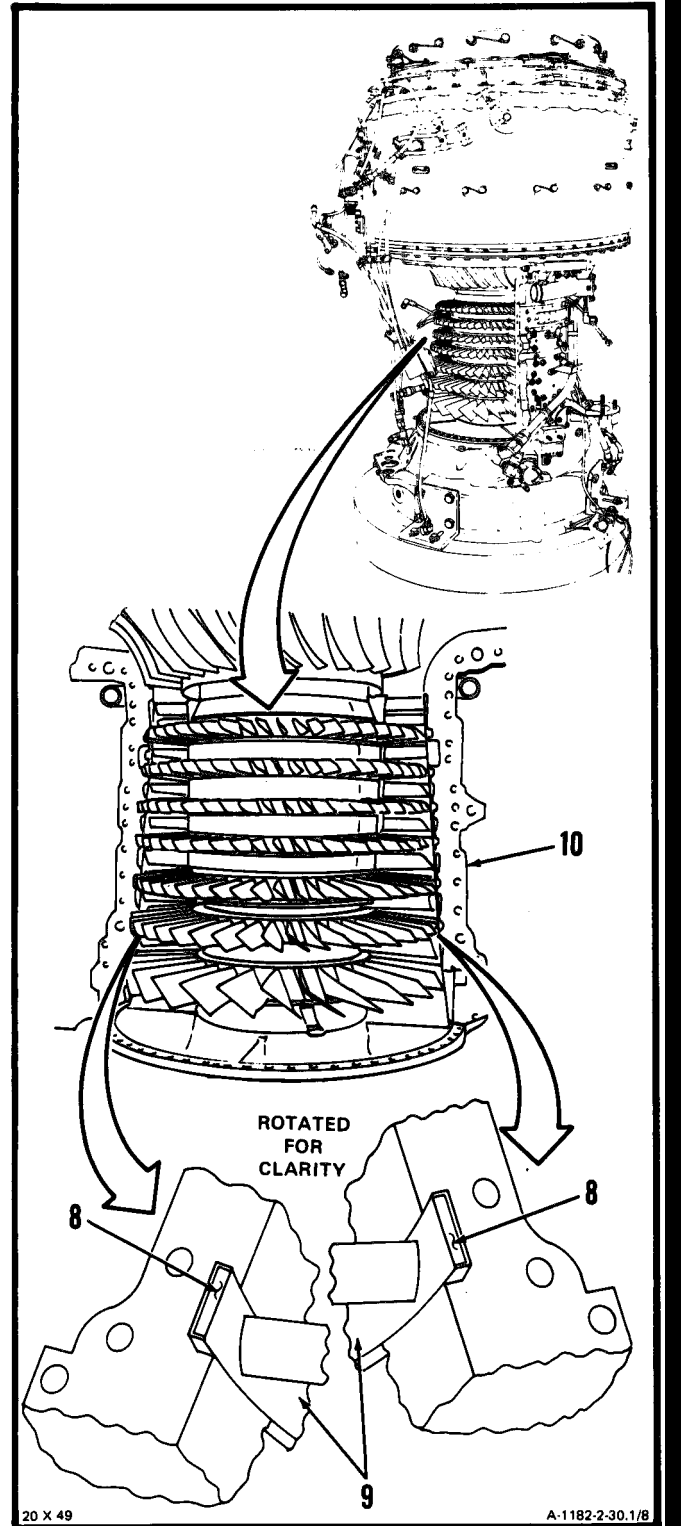
**GO TO NEXT PAGE**

2-30.1 INSTALL RTV FIRST STAGE STATOR VANE ASSEMBLY (Continued)

2-30.1

- b. Apply non-lead gear marking compound (E38.1) to both ends (11) of stator vane shroud (12) on removed compressor housing half (13).
- c. **Temporarily install removed compressor housing half** (Ref. Task 2-24, steps 1 thru 3. or Task 2-25, steps 1. thru 3.).
- d. **Remove temporarily installed compressor housing half** (Ref. Task 2-19, steps 29. thru 32. and 38. or Task 2-20, steps 35. thru 38. and 48.)
- e. Inspect both ends (11) of stator vane shroud (12) of removed compressor housing half (13). There shall be no non-lead gear marking compound visible.
- f. If no non-lead gear marking compound is visible, clearance is acceptable.
- g. If non-lead gear marking compound is visible proceed as follows:
- (1) Loosen stator vane mounting bolts, shift stator vane and retorque mounting bolts (Refer to steps 1. thru 7).
 - (2) Repeat steps 3a. thru 3.e.
 - (3) If non-lead gear marking compound is still visible, proceed as follows:

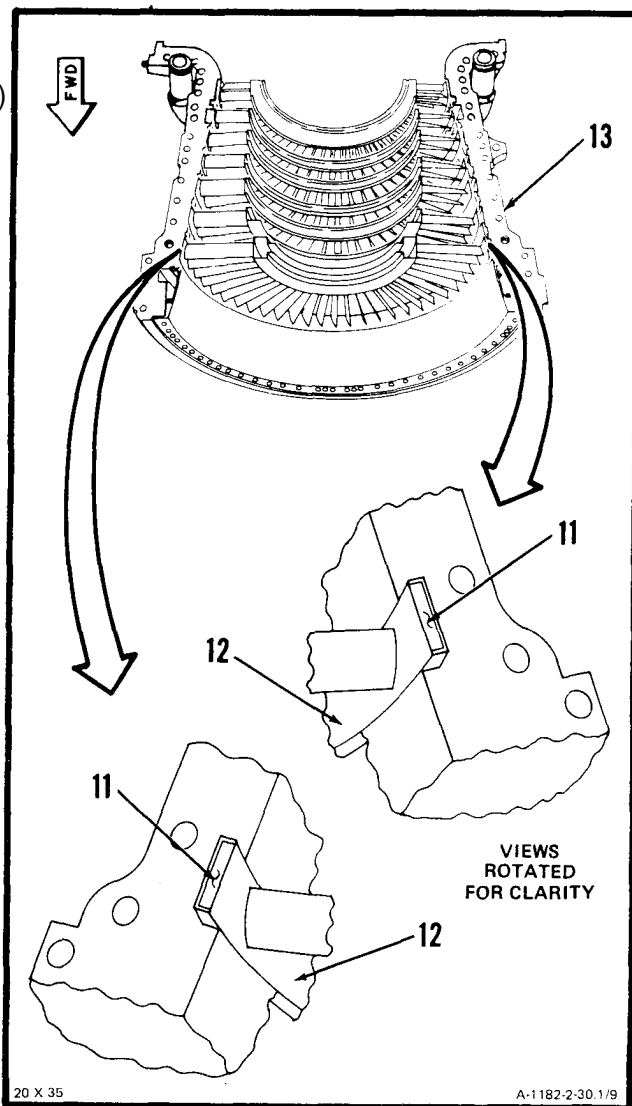
**GO TO NEXT PAGE**

2-30.1 INSTALL RTV IN FIRST STAGE STATOR VANE ASSEMBLY (Continued)

2-30.1

- (a) Remove stator vane assembly. (Ref. Task 2-26).
- (b) File shroud ends (14). Use flat hand file.
- (c) Clean stator vane assembly. (Ref. Task 2-27).
- (d) Install stator vane assembly (steps 1 thru 7).
- (e) Repeat steps 8. a. thru e.
- (f) If non-lead gear marking compound is still visible, repeat step 3.h., (3), (a) thru (f).
- (g) Wear gloves (E20). Using dry cleaning solvent (E17) and brush, clean off all non-lead gear marking compound. Wipe dry using lint-free cloth (E26).

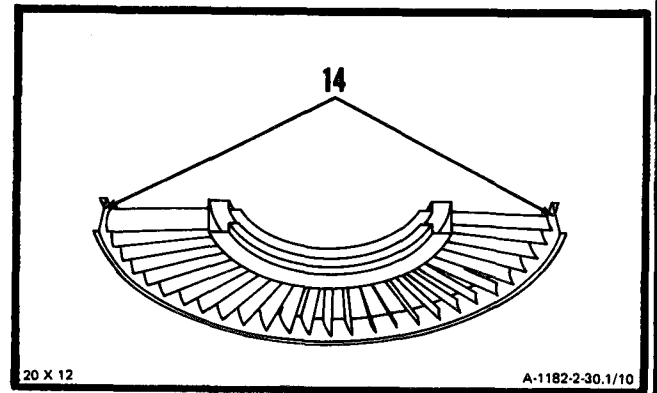
**GO TO NEXT PAGE**

2-30.1 INSTALL RTV IN FIRST STAGE STATOR VANE ASSEMBLY (Continued)

2-30.1

i. Install first stage stator vane retainers. detail of RTV masking kit (T36.1) as follows:

(1) Install aft retainer (15) with chamfered edge of (16) toward first stage stator vane (17).

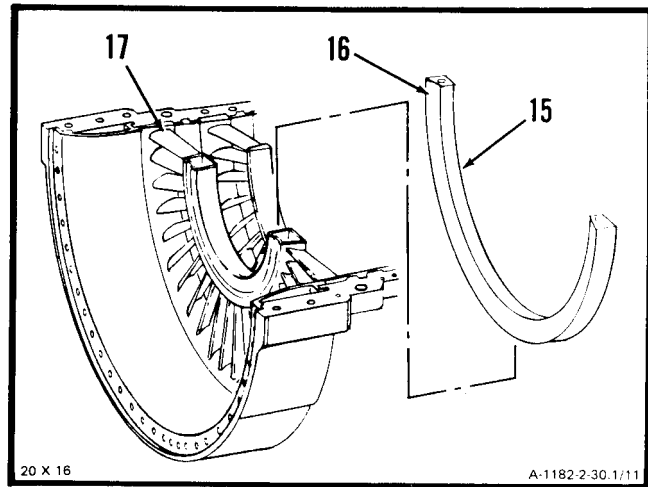

(2) Install forward retainer (18) with cutouts toward first stage stator vane (17).

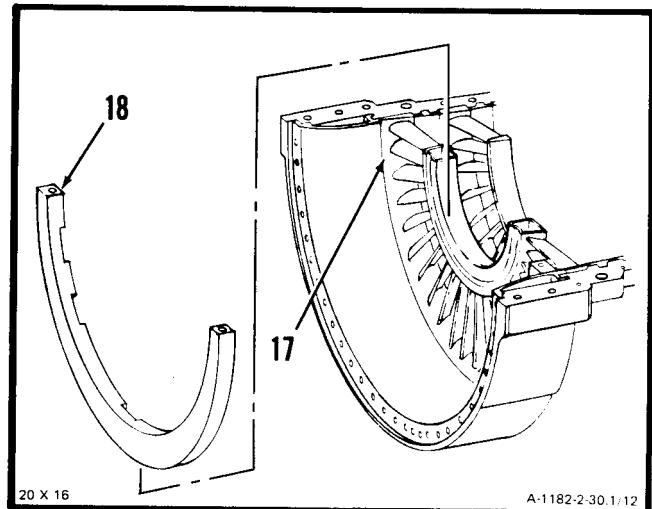

NOTE

Make sure forward and aft retainers are tightly secured against first stage stator vane.

(3) Install two clamps (19) and four screws (20). Tighten screws evenly to clamp retainers in place.

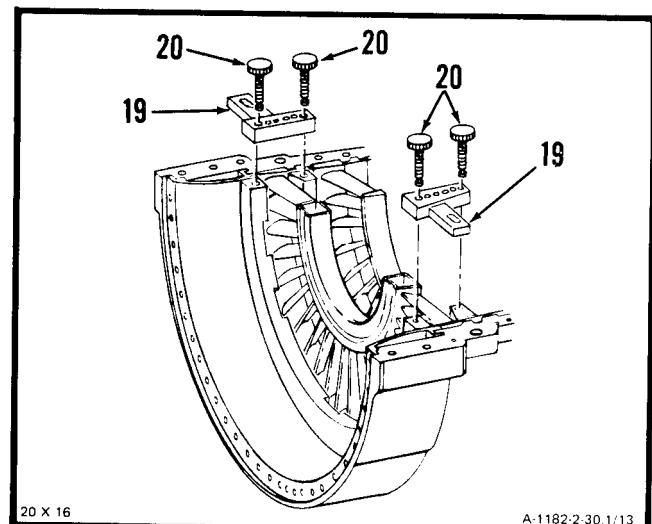

GO TO NEXT PAGE

2-30.1 INSTALL RTV IN FIRST STAGE STATOR VANE ASSEMBLY (Continued)

2-30.1

- (4) Install two bolts (21), two washers (22), and two nuts (23). Stagger tighten evenly to clamp retainers in place.

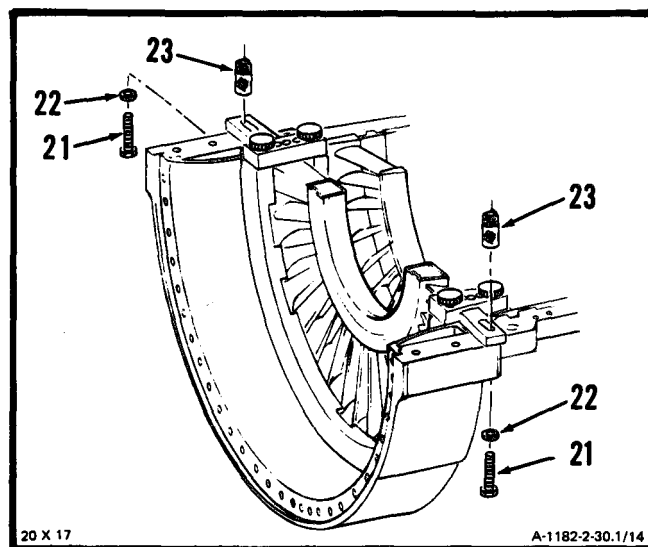

GO TO NEXT PAGE

j. Prepare RTV application kit (T38.1) as follows:

- (1) **Hold cartridge (24).** Grasp mixing rod (25) and pull back about one inch.

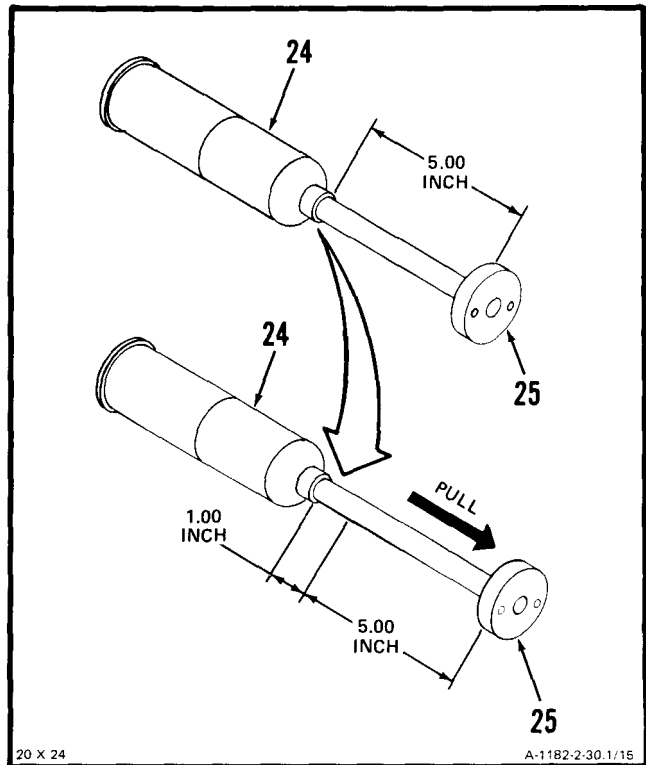

- (2) **Insert ramrod (26)** into hold (27) at top of mixing rod (25).

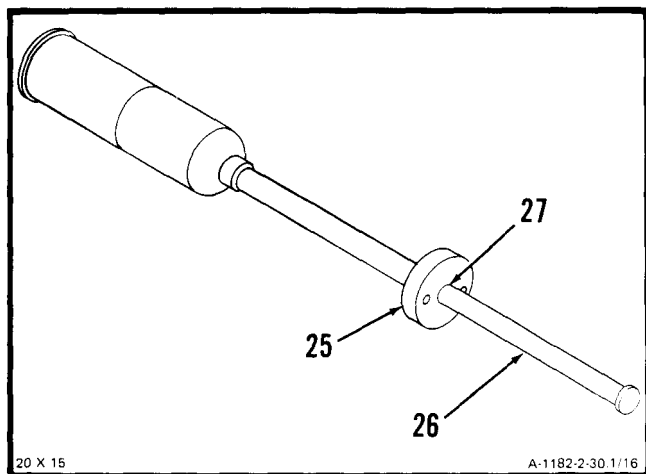

GO TO NEXT PAGE

2-30.1 INSTALL RTV IN FIRST STAGE STATOR VANE ASSEMBLY (Continued)

2-30.1

NOTE

In following step, use even pressure. Do not use excess force, tap, pound or jolt ramrod if piston does not break loose easily.

- (3) **Inject all of catalyst into** cartridge (24) by pushing ramrod (26) into mixing rod (25).
- (4) **Remove ramrod (26)** from mixing rod (25).

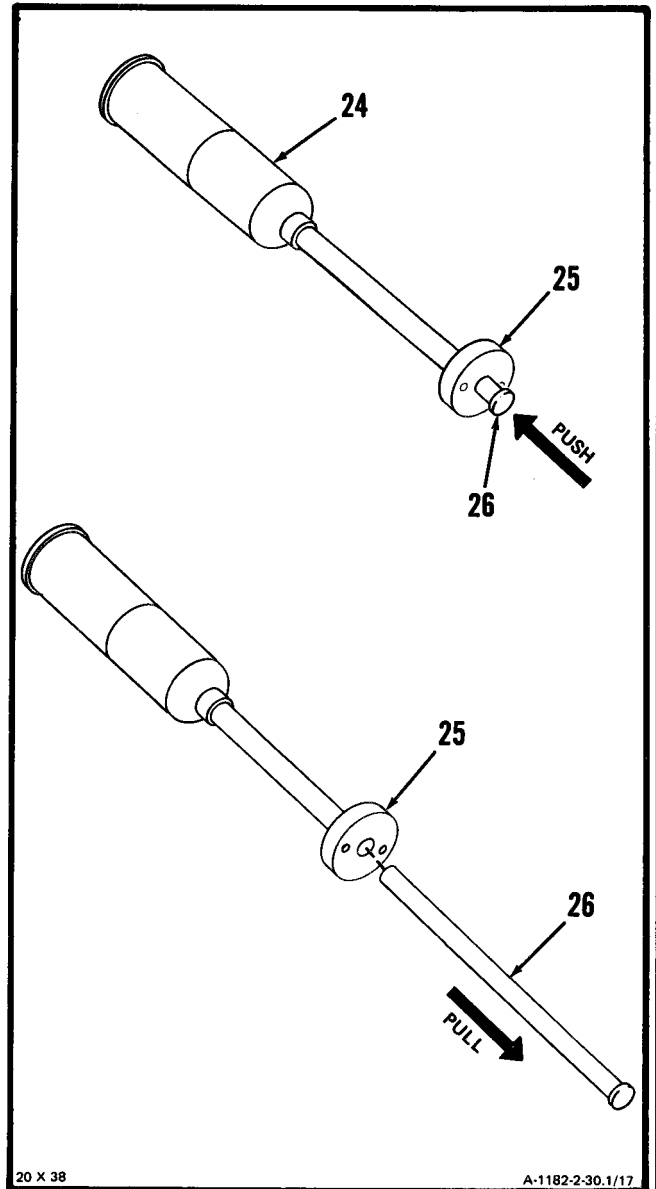

20 X 38

A-1182-2-30.1/17

GO TO NEXT PAGE

2-30.1 INSTALL RTV IN FIRST STAGE STATOR VANE ASSEMBLY (Continued)

2-30.1

- (5) **Pull mixing rod (25)** from cartridge (24) until it is fully extended.

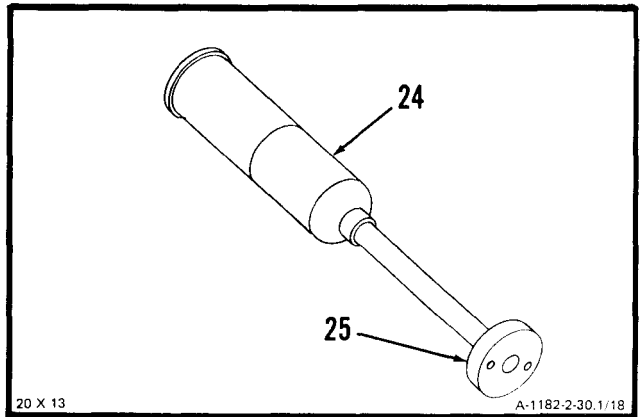

- (6) **Turn cartridge (24) upside down.** Align hole in center of mixing rod (25) with drive screw (28) of mixer (29), detail of RTV masking kit (T36.1) .

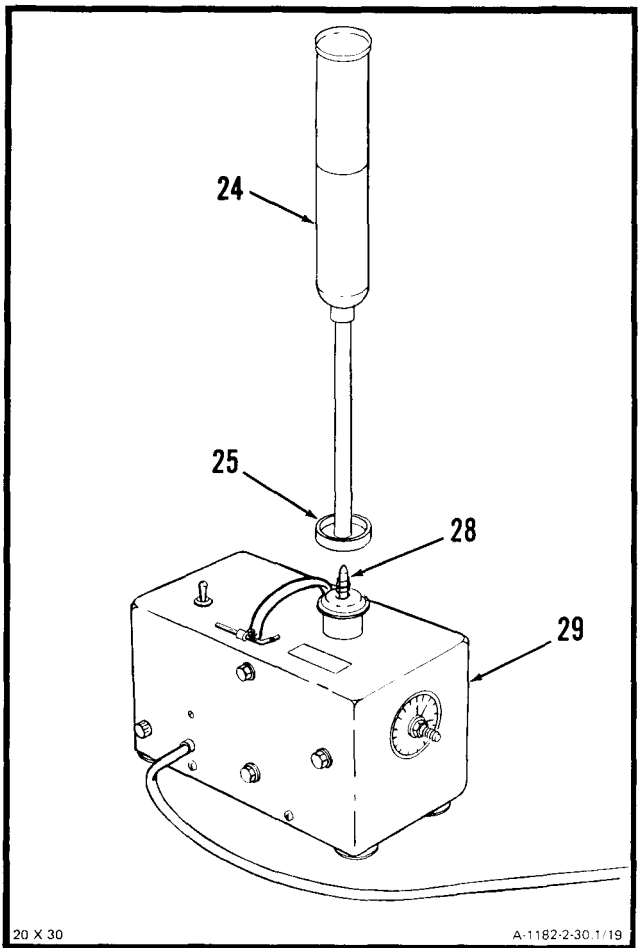

GO TO NEXT PAGE

2-30.1 INSTALL RTV IN FIRST STAGE STATOR VANE ASSEMBLY (Continued) 2-30.1

- (7) **Grasp mixing rod (25) firmly** and turn mixer switch (30) to MIX position. Turn mixer OFF as soon as drive screw (28) is totally engaged.

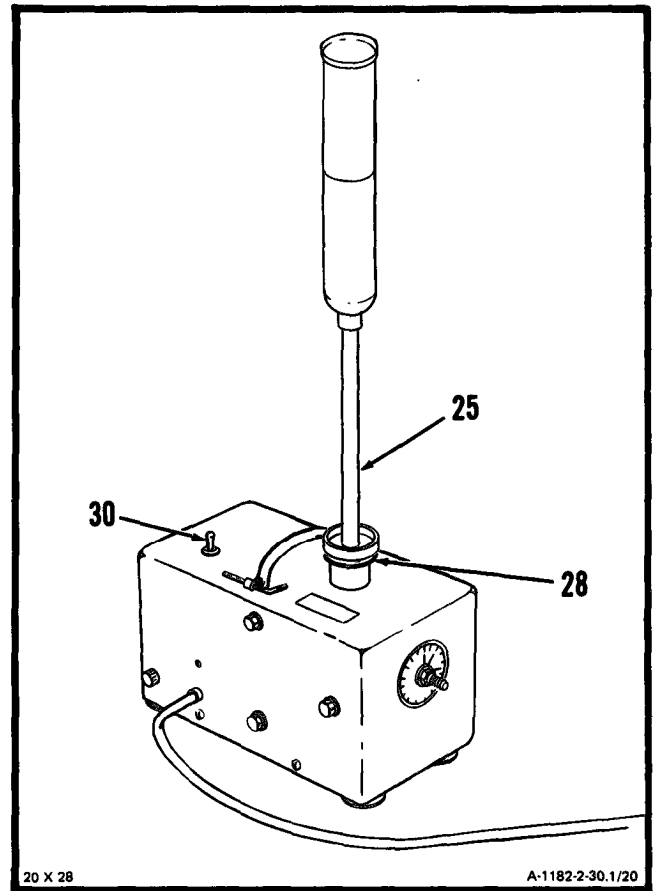

GO TO NEXT PAGE

CAUTION

If mixer switch is in REVERSE position, the internal mixing paddle will disconnect from shaft and result in improper mixing.

- (8) Grasp cartridge (24) firmly. Turn mixer switch (30) to mix position. Set timer (31) for four minutes.

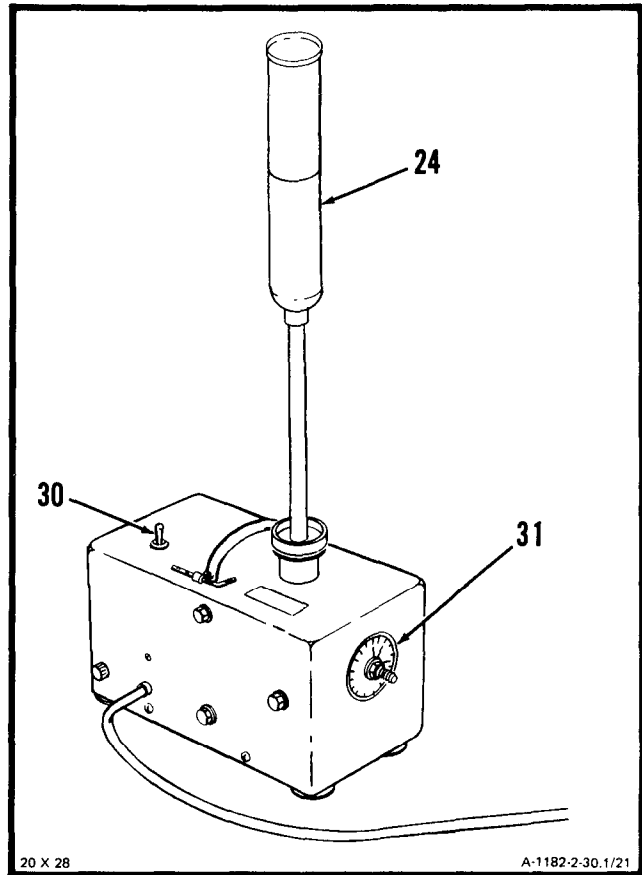

GO TO NEXT PAGE

2-30.1 INSTALL RTV IN FIRST STAGE STATOR VANE ASSEMBLY (Continued)

2-30.1

- (9) **Move cartridge (24) up and down.** The internal mixing paddle must traverse the entire filled length of the cartridge (24).

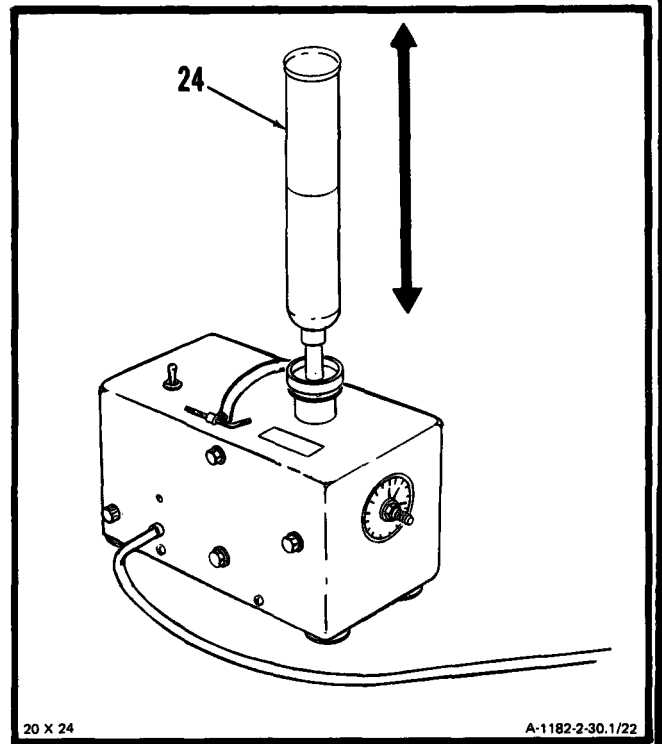

GO TO NEXT PAGE

2-30.1 INSTALL RTV IN FIRST STAGE STATOR VANE ASSEMBLY (Continued)

2-30.1

- (10) When bell rings on timer **turn mixer switch (30) OFF**. Mixing rod (25) should be fully extended at this time.

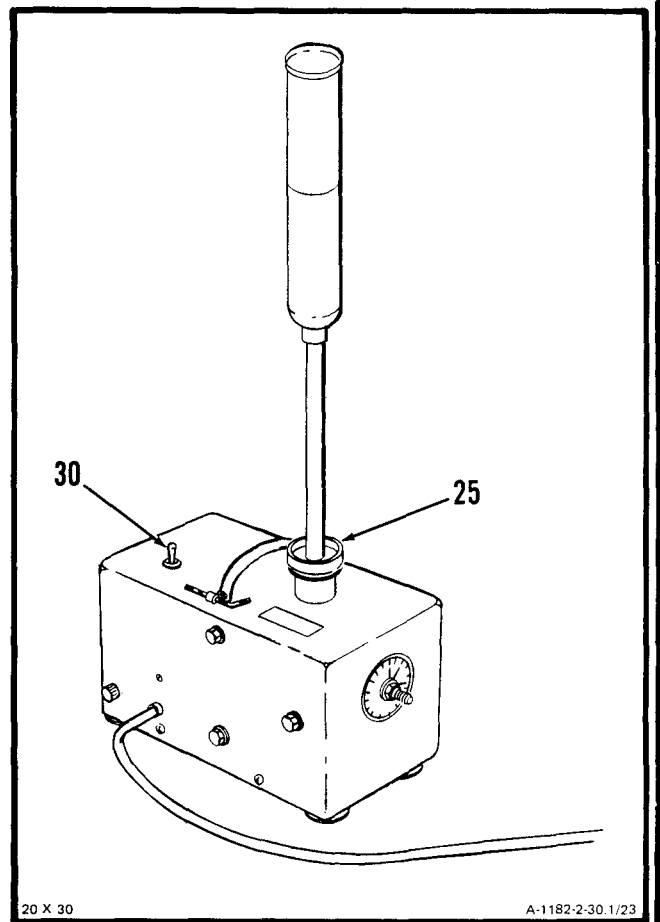

GO TO NEXT PAGE

2-30.1 INSTALL RTV IN FIRST STAGE STATOR VANE ASSEMBLY (Continued)

2-30.1

- (11) **Grasp mixing rod (25) firmly and turn mixer switch (30) to REVERSE position.** This will unscrew mixing rod (25) from internal drive screw assembly. When mixing rod is free, turn mixer switch (30) to OFF position.

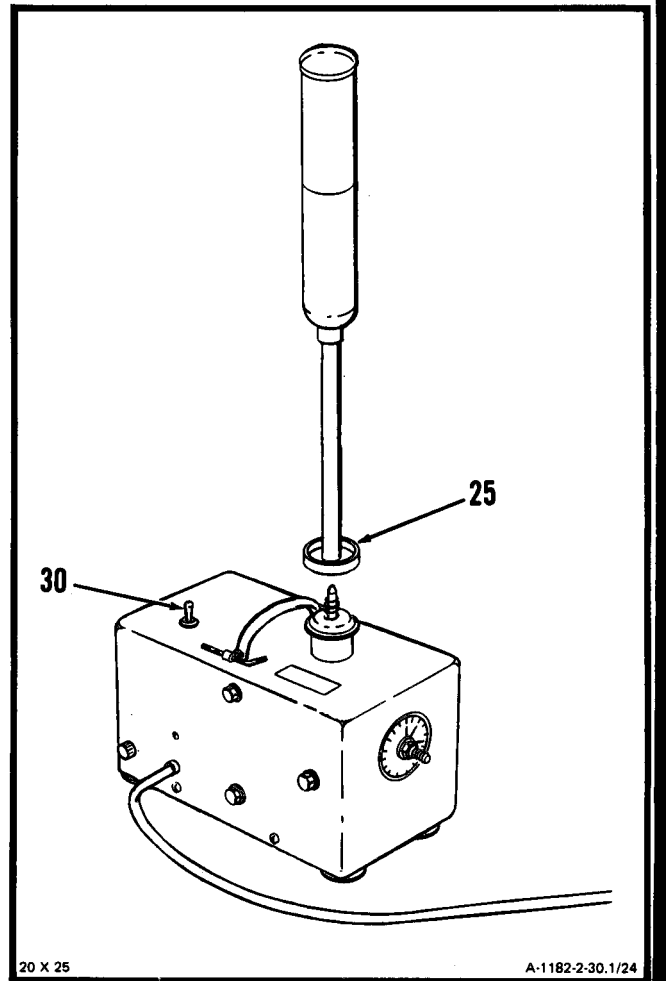

GO TO NEXT PAGE

2-30.1 INSTALL RTV IN FIRST STAGE STATOR VANE ASSEMBLY (Continued)

2-30.1

- (12) **Grasp cartridge (24)** with mixing rod (25) fully extended.
- (13) **Rotate mixing rod (25)** counterclockwise to disengage internal mixing paddle.
- (14) **Withdraw mixing rod (25).**

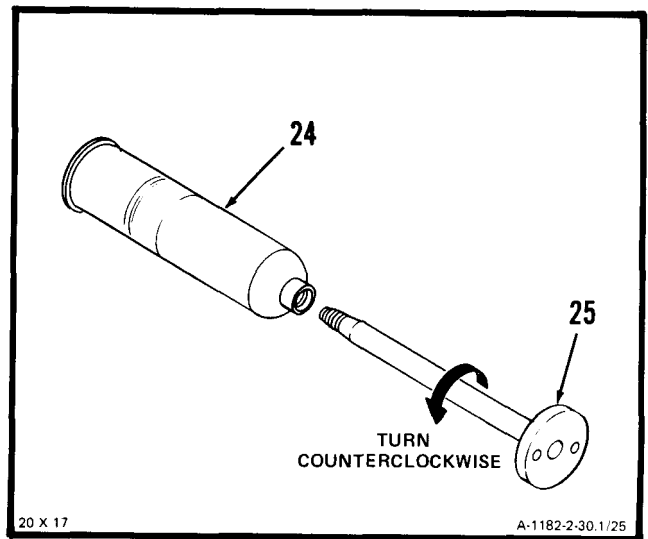
**GO TO NEXT PAGE**

2-30.1 INSTALL RTV IN FIRST STAGE STATOR VANE ASSEMBLY (Continued) 2-30.1

(15) Prepare injection tip as follows:

- (a) If Semko No. 410 or No. 440 nozzle, detail of RTV application kit (T38.1) is being used, cut tip (32) on a 5 degree angle to expose a 0.125 inch orifice.

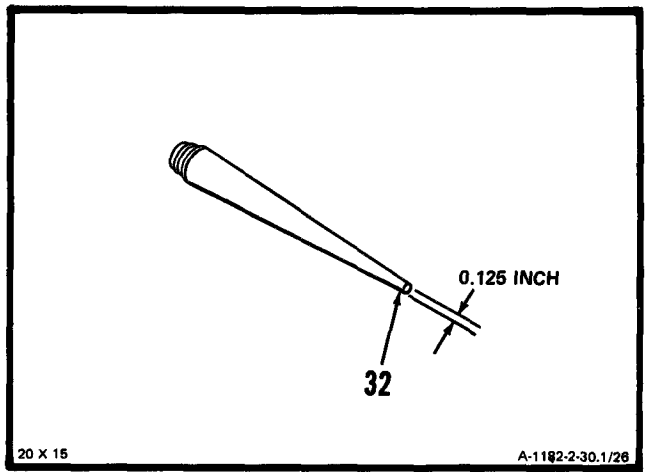

- (b) If Philip Fishman No. FN-250-12-5 needle, detail of application kit (T38.1) is used, slide cover (33) over needle (34).

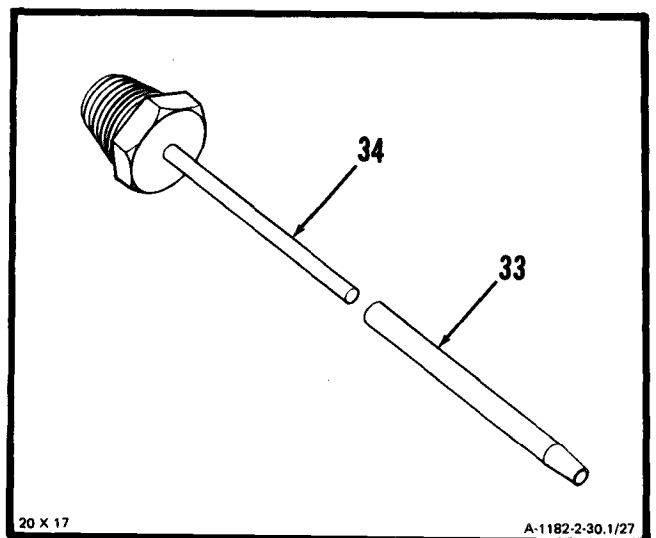

GO TO NEXT PAGE

- (16) **Install injection tip (32)** on cartridge (24).

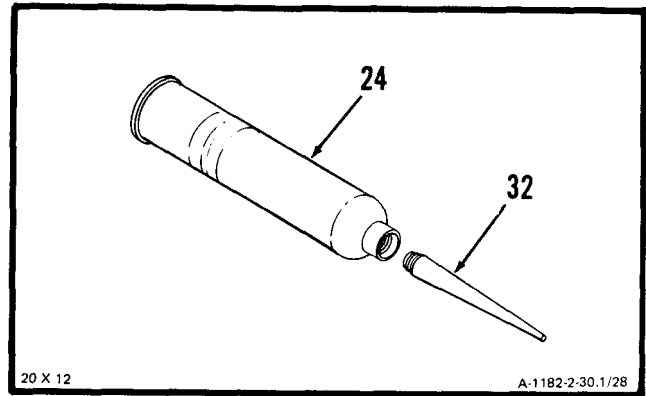

- (17) Remove cap (35) from RTV cartridge assembly (36) and **install cartridge assembly (36)** in cartridge holder (37).

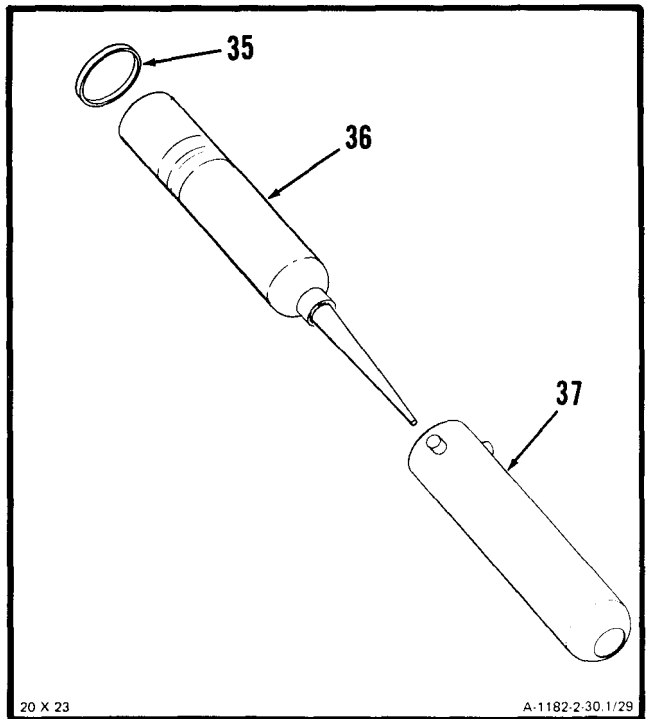

GO TO NEXT PAGE

2-30.1 INSTALL RTV IN FIRST STAGE STATOR VANE ASSEMBLY (Continued)

2-30.1

- (18) Install cartridge holder assembly (38) on injection gun (39). Turn cartridge holder assembly (28) clockwise until pin (40) engages slot (41) on injection gun (39).
- (19) Secure cartridge holder assembly (38) to injection gun (39) by turning knob (42) clockwise until it seats firmly.

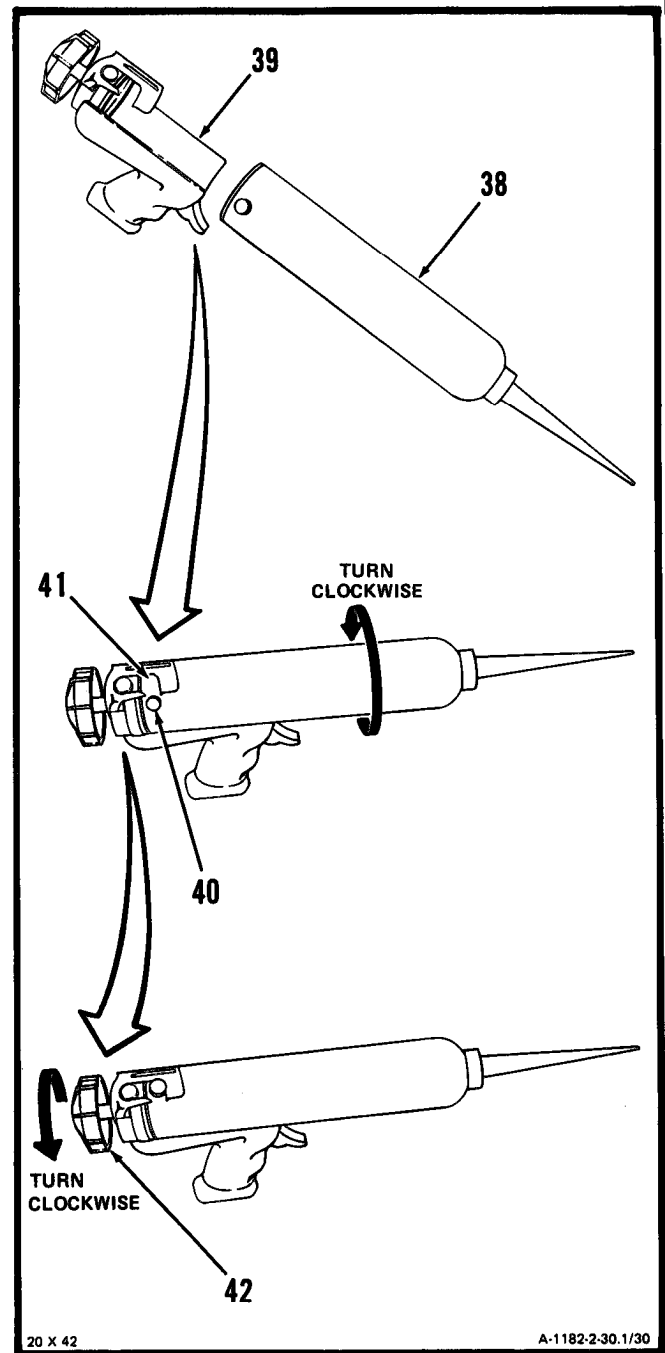
**GO TO NEXT PAGE**

2-30.1 INSTALL RTV IN FIRST STAGE STATOR VANE ASSEMBLY (Continued)

2-30.1

(20) Install shop air hose (43) on injection gun assembly (44).

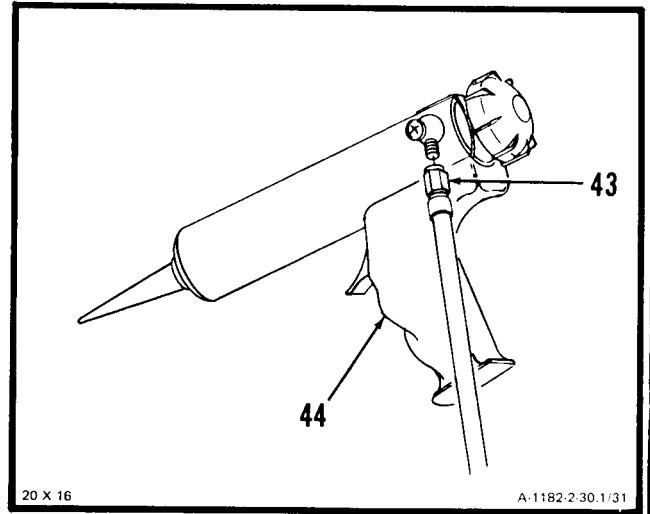

GO TO NEXT PAGE

(21) **Position compressor housing half (3)** facing up and level.

(22) Adjust air pressure regulator to 60 psi.
Inject RTV as follows:

- (a) **Inject RTV through five holes (45)** in stator outer shroud (46) starting with center hole marked 1 and work in sequence alternately toward housing splitline (47).
- (b) Inject all five holes (45) until RTV begins to flow out through the five 1.500 inch slots in forward retainer (18).

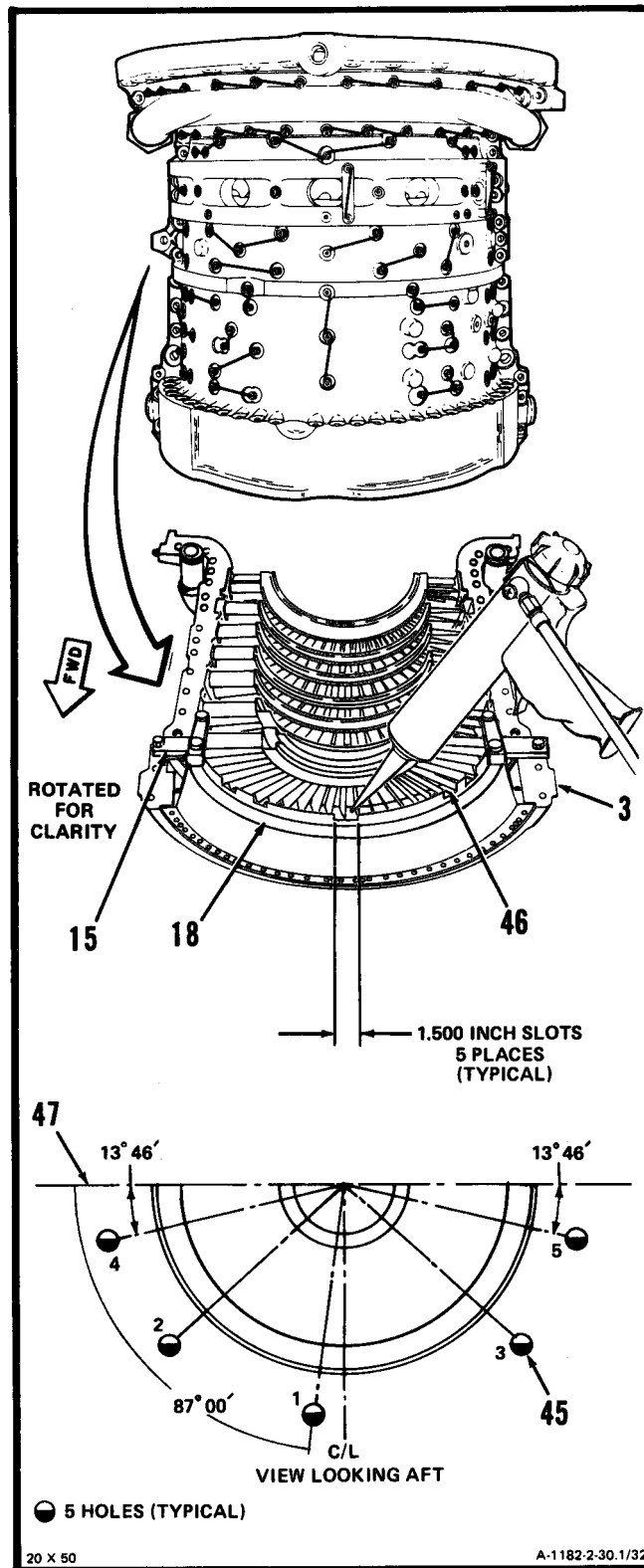

GO TO NEXT PAGE

(c) **Fill outer shroud (46) splitline cavities (48) with RTV.**

- (23) **Place compressor housing half (3) in oven** and cure for three hours at 225 degrees F. Ensure compressor housing is level. If suitable oven is not available, allow to cure at ambient temperature for 24 hours.
- (24) Remove compressor housing from oven and allow to cool for 1/2 hour.

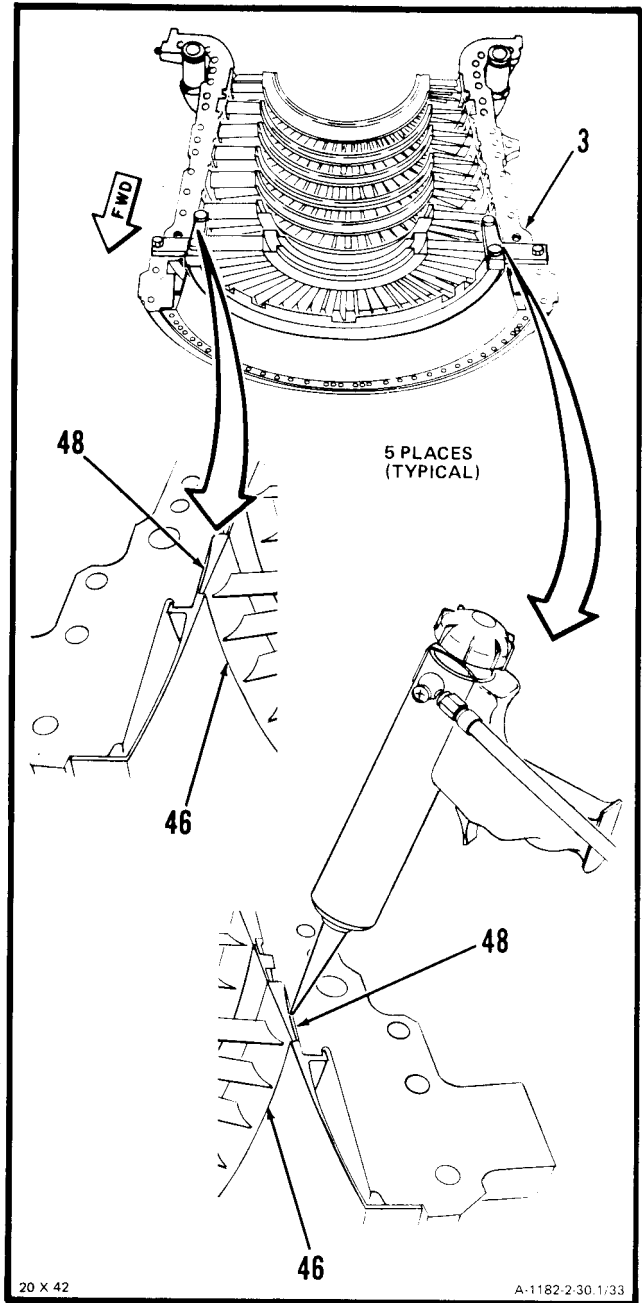

GO TO NEXT PAGE

2-30.1 INSTALL RTV IN FIRST STAGE STATOR VANE ASSEMBLY (Continued) 2-30.1

(a) Remove first stage stator retainers, details of RTV masking kit (T36.1) as follows:

- 1 Remove two bolts (21), two washers (22), and two nuts (23).

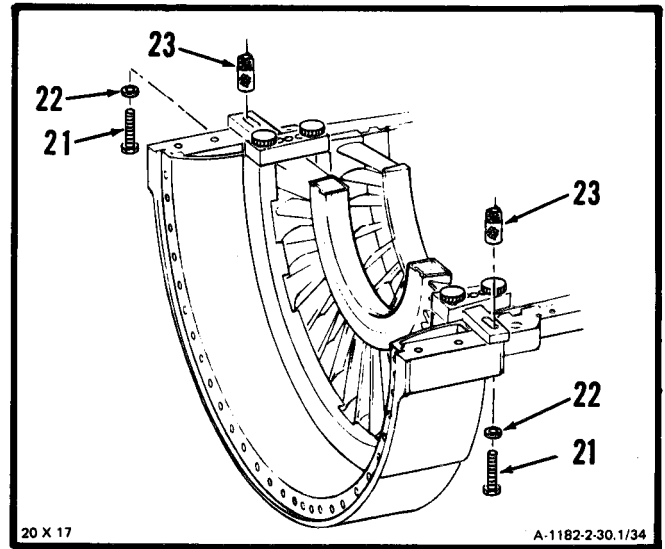

- 2 Remove two screws (20) from aft retainer (15). Remove two clamps (19) and forward retainer (18) from compressor housing half (3).

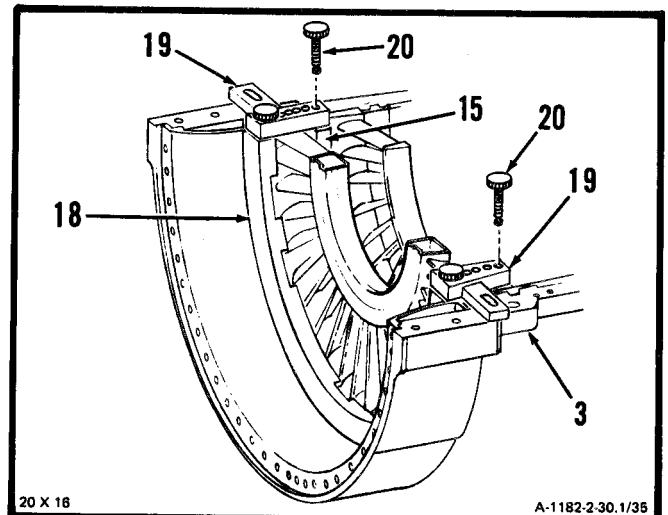

- 3 Install two screws (20) into aft retainer (15) and remove aft retainer (15) from compressor housing half (3).

Using tongue depressor, remove excess RTV from compressor housing half (3) and splitline cavities (48).

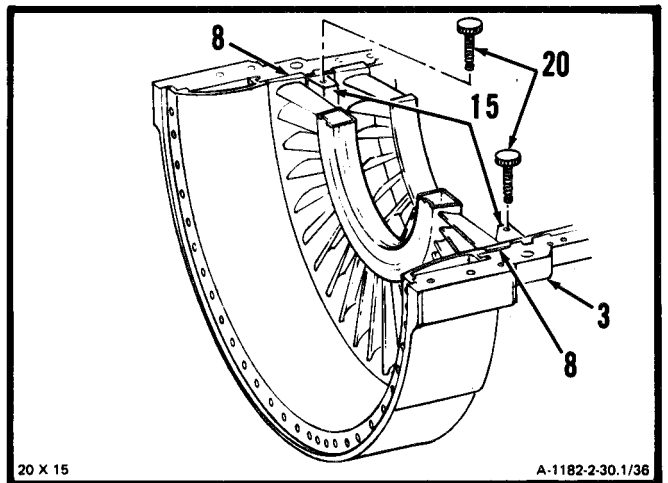

GO TO NEXT PAGE

2-30.1 INSTALL RTV IN FIRST STAGE STATOR VANE ASSEMBLY (Continued) 2-30.1

FOLLOW-ON MAINTENANCE:

Install Upper Compressor Housing (Task 2-24) or Lower Compressor Housing (Task 2-25).

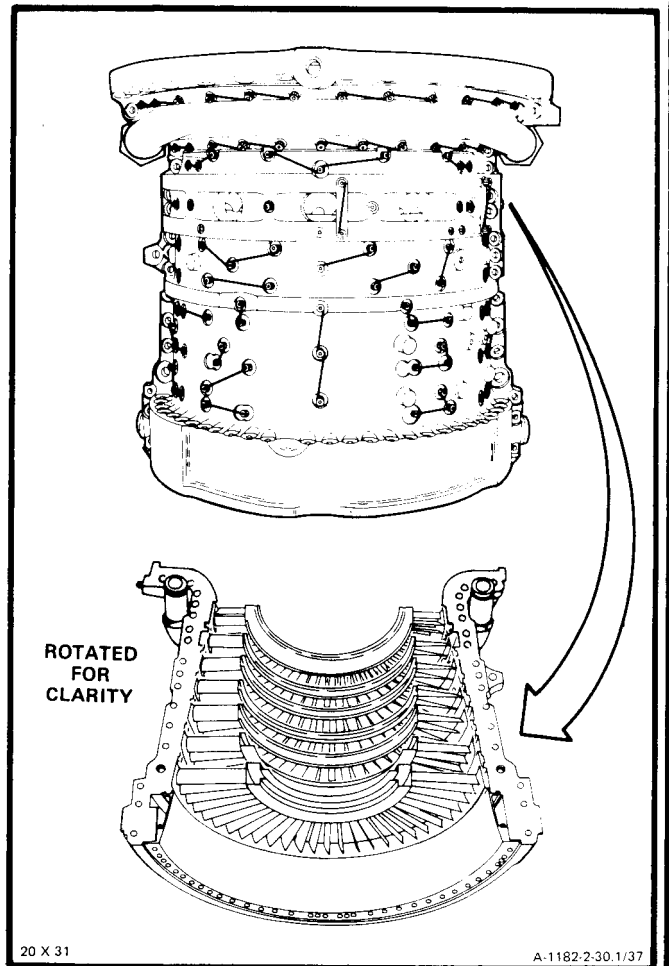

END OF TASK

Section VI. COMPRESSOR ROTOR BLADES - MAINTENANCE PROCEDURES

2-31 REMOVE COMPRESSOR ROTOR BLADES

2-31

INITIAL SETUP**Applicable Configurations:**

All

Tools:

Powerplant Mechanic's Tool Kit,
NSN 5180-00-323-4944
Drift Assembly (T19)
Installing Tool (T20)
Tweezers, NSN 5120-00-247-0868
Twist Drill, NSN 5133-00-232-6398

Materials:

Masking Tape (E35)

Personnel Required:

68B10 Aircraft Powerplant Repairer

Equipment Condition:

Engine Oil System Drained (Task 1-75)
Oil Cooler Assembly Removed (Task 8-5)
In-Line Fuel Filter Assembly Removed
(Task 6-36)
Ignition Exciter Removed (Task 7-11)
Oil Filler Assembly and Oil Filler Strainer
Removed (Task 8-16)
Starter Drive Assembly Removed (Task 5-12)
Main Fuel Filter and Bracket Removed
(Task 6-29)
Interstage Air-Bleed Actuator Removed
(Task 2-1).
Compressor Bleed Band Removed (Task 2-9)
Upper Compressor Housing Removed
(Task 2-19)

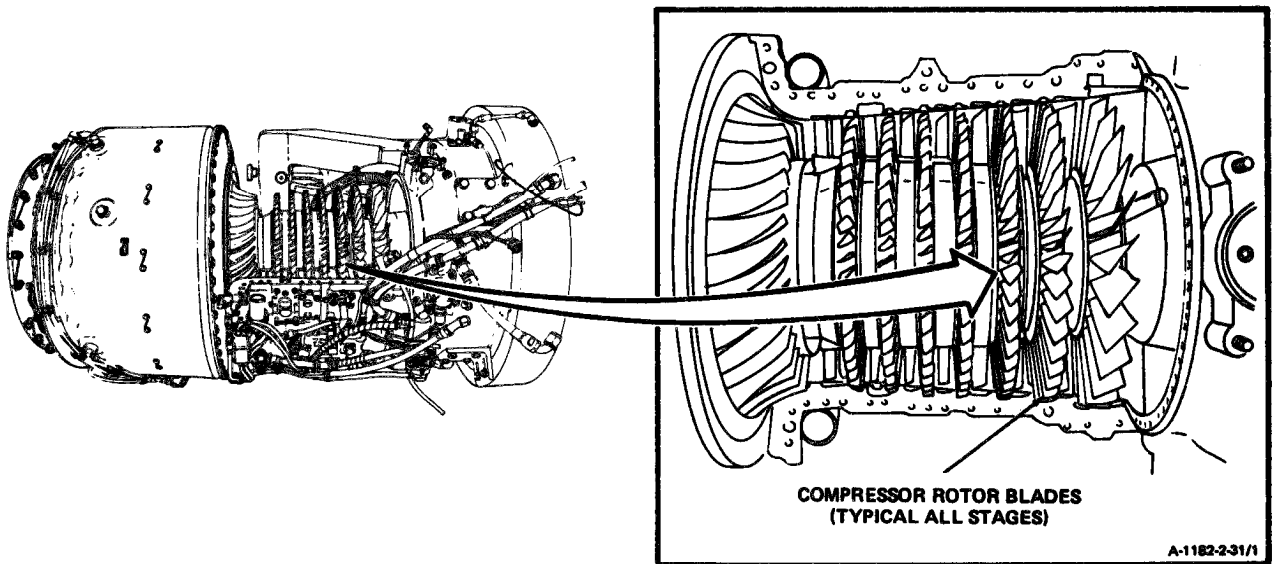
**GO TO NEXT PAGE**

NOTE

Number of blades and stages in which they were replaced must be entered in engine record. Maximum of 50 blades may be replaced on compressor rotor between overhaul cycles.

NOTE

First, second and third stage blades are removed forward. Removal of first stage blade is shown in step 1.

CAUTION

When removing compressor blades, be certain that blade, pieces of lockpin, and spring do not fall into lower compressor housing. These items could cause compressor rotor malfunction. If these items do fall into lower compressor housing, they must be removed.

1. Remove first stage blade (1) from disc as follows:
 - a. Align forward blade root (2) with slot (3) in bearing housing.

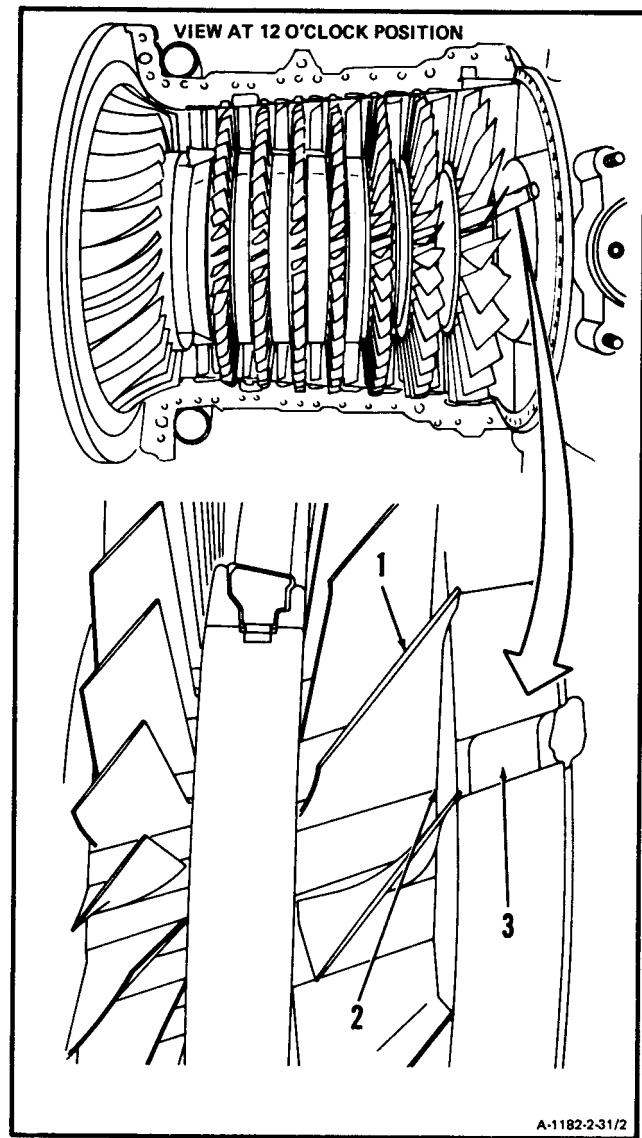

GO TO NEXT PAGE

2-31 REMOVE COMPRESSOR ROTOR BLADES (Continued)

2-31

b. Twist masking tape (E35) (4), sticky side out, as shown. Make the tape (4) 1/2-inch wide.

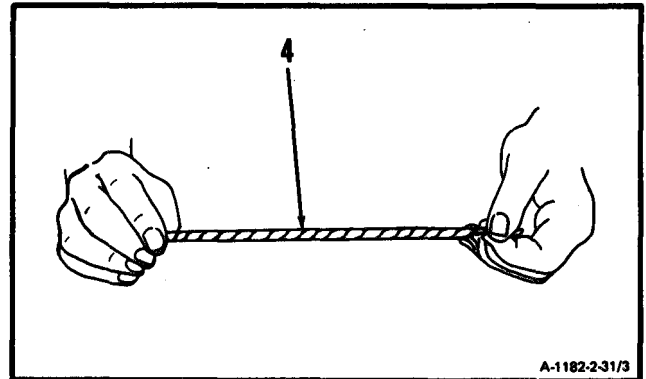

c. Insert masking tape (E35) (4) into space forward of first stage disc (5). Use punch (6) for insertion.

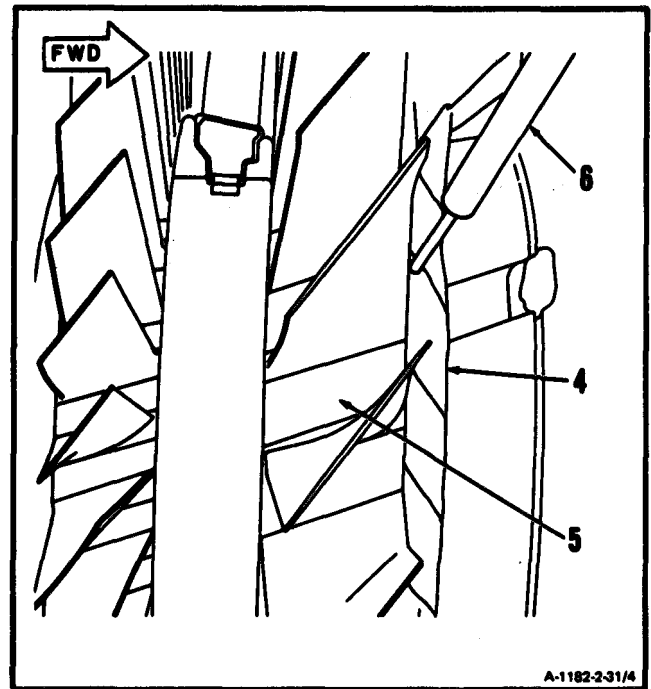

GO TO NEXT PAGE

d. Position drift assembly (T19) (7) at rear of blade (1).

CAUTION

In following step, be sure that blade root is aligned with slot. Failure to comply will cause damage to No. 1 bearing housing.

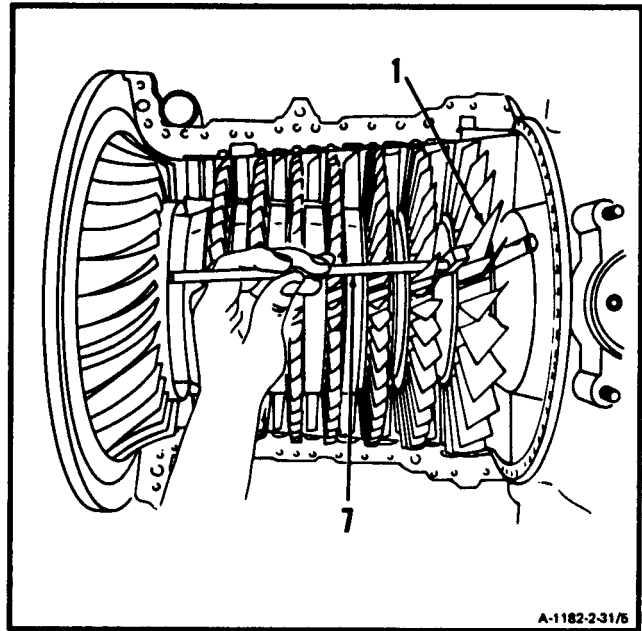

e. Tap blade (1) firmly forward into slot (3). Use ballpeen hammer.

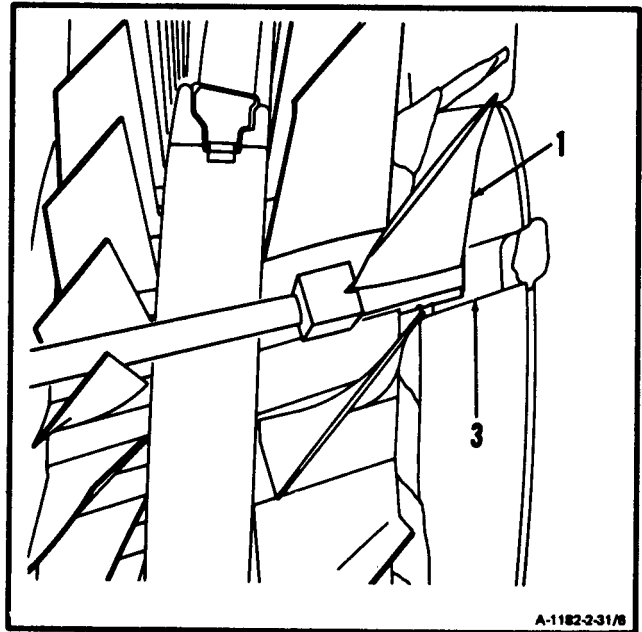

GO TO NEXT PAGE

- f. Continue to tap blade (1) forward until lock-pin (8) is sheared.

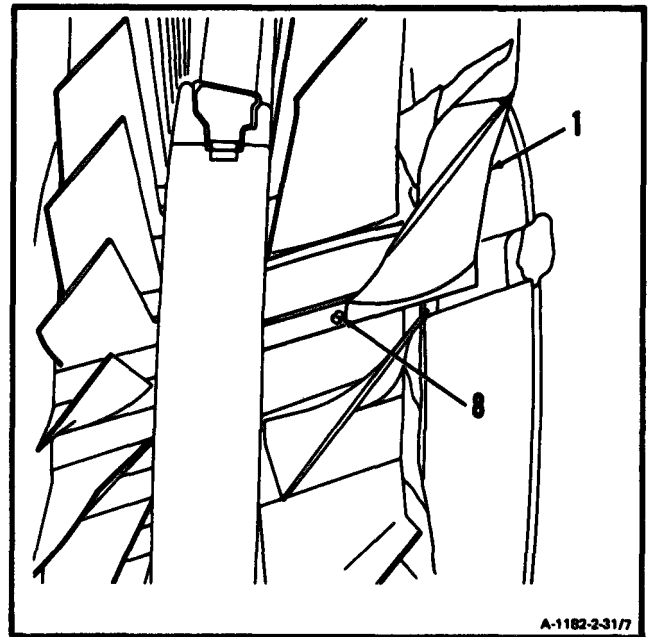

GO TO NEXT PAGE

- g. Move blade (1) forward and **remove sheared lockpin (8)**. Use tweezers (9).

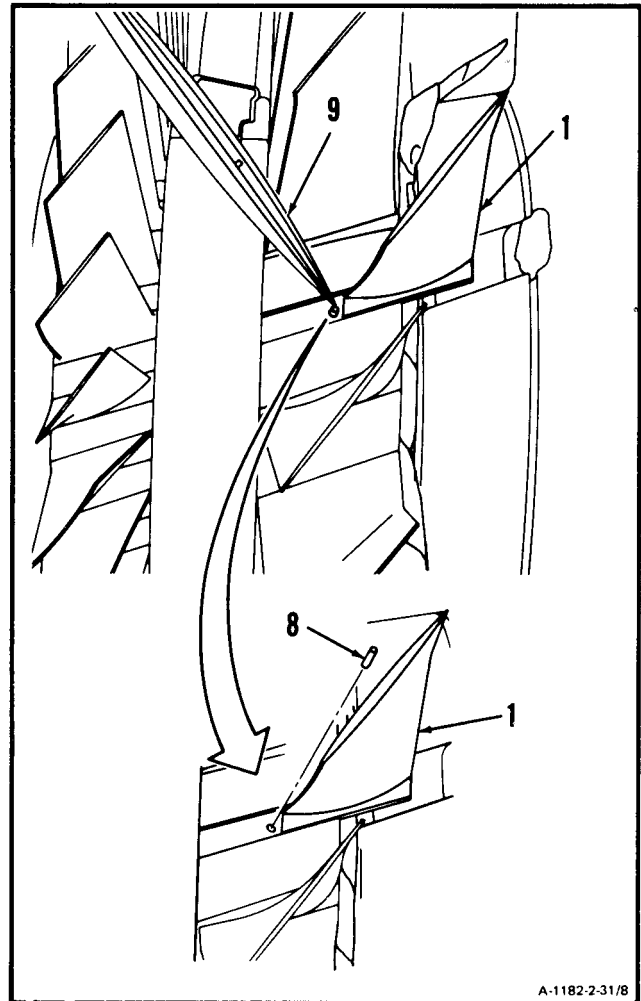

A-1182-2-31/8

GO TO NEXT PAGE

2-31 REMOVE COMPRESSOR ROTOR BLADES (Continued)

2-31

h. **Remove spring (10).** Use tweezers (9).

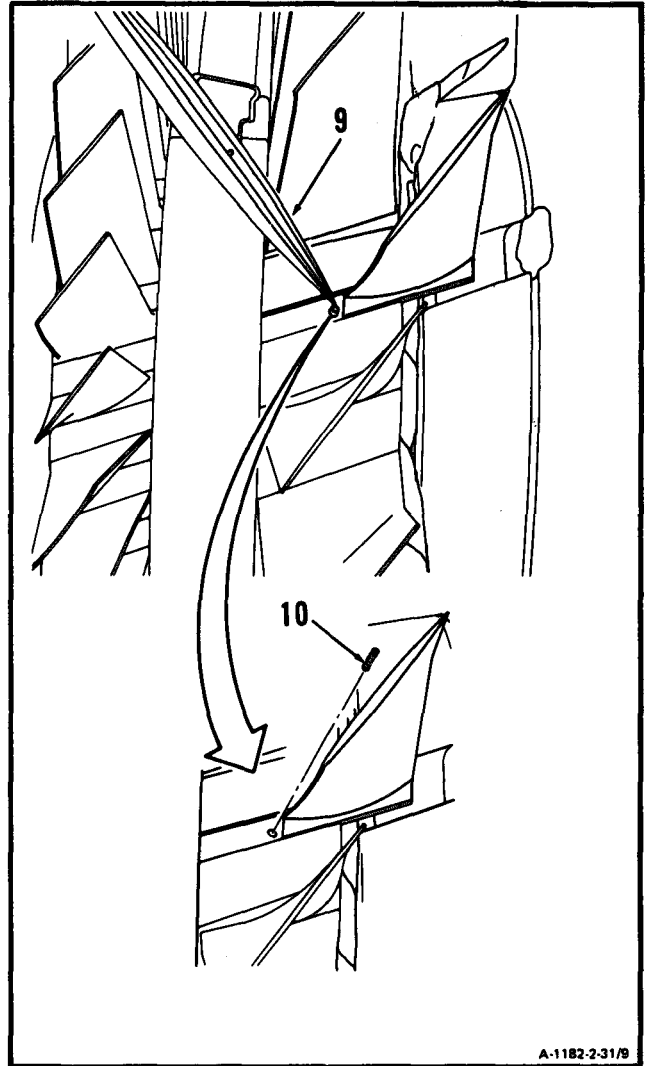

GO TO NEXT PAGE

- i. Remove first stage compressor blade (1).
- j. Remove sheared lockpin (8) from blade (1).
Use tweezers (9).

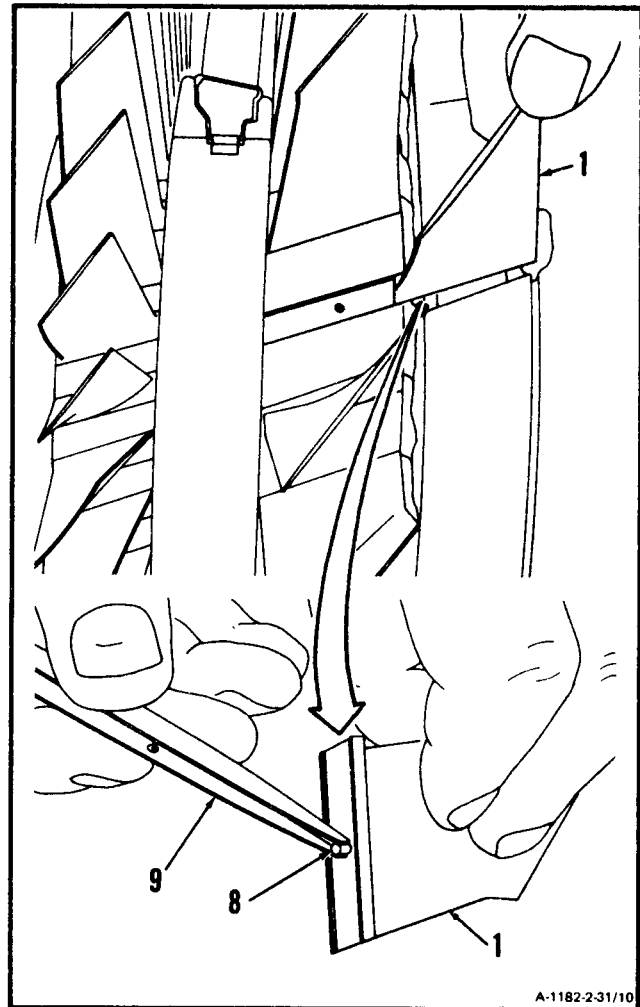

GO TO NEXT PAGE

CAUTION

Do not remove any parent metal from inside lockpin hole. Removing material will enlarge hole. If this happens, compressor rotor assembly will have to be replaced.

- k. Clean out lockpin hole (11). Use twist drill (12). Remove tape.

NOTE

Second and third stage blades are removed forward. Removal of third stage blade is shown.

2. Remove third stage compressor blades (13) as follows:

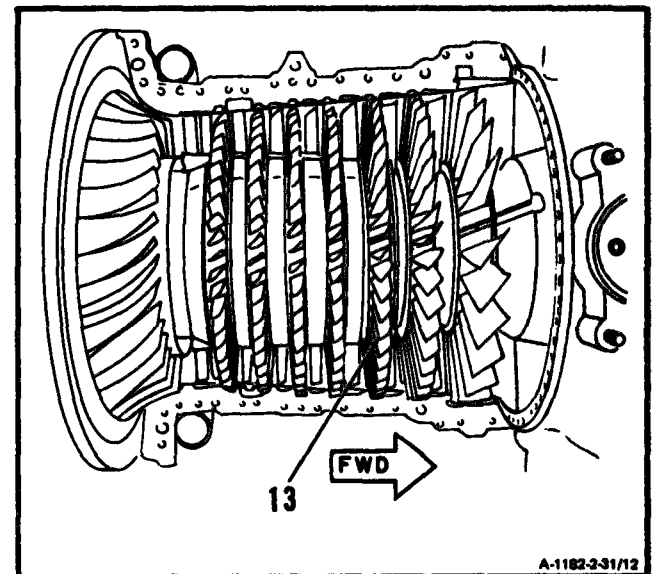
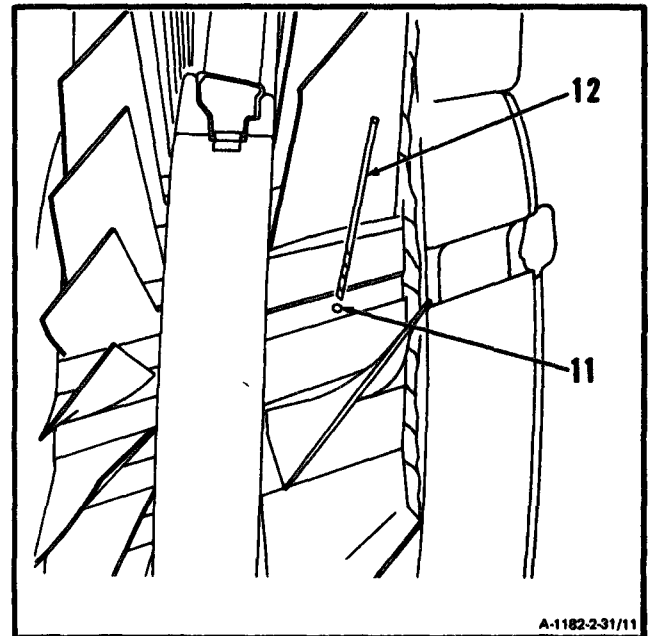

GO TO NEXT PAGE

a. Twist masking tape (E35) (4), sticky side out. Make the tape 1/2-inch wide.

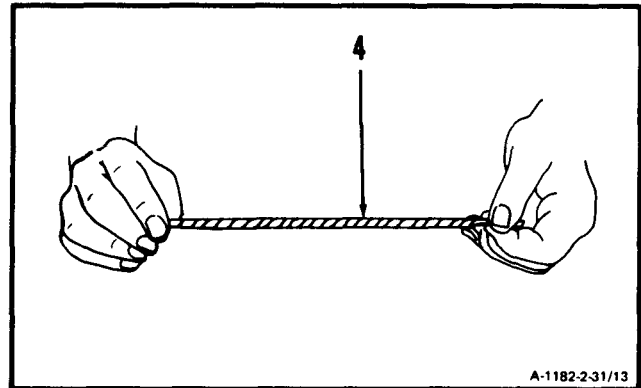

b. Insert masking tape (E35) (4) into space forward of third stage disc (14).

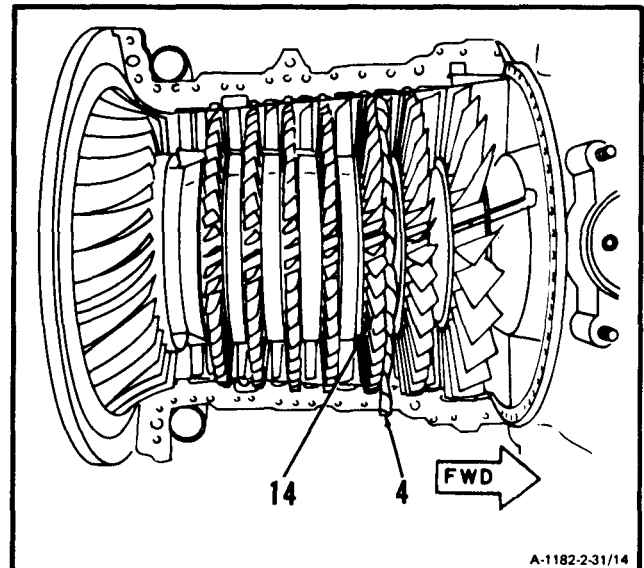

GO TO NEXT PAGE

NOTE

Use drift assembly (T19) for second stage blades. Use installing tool (T20) for third stage blades.

- c. **Position installing tool (T20) (15) at rear of blade (13).**

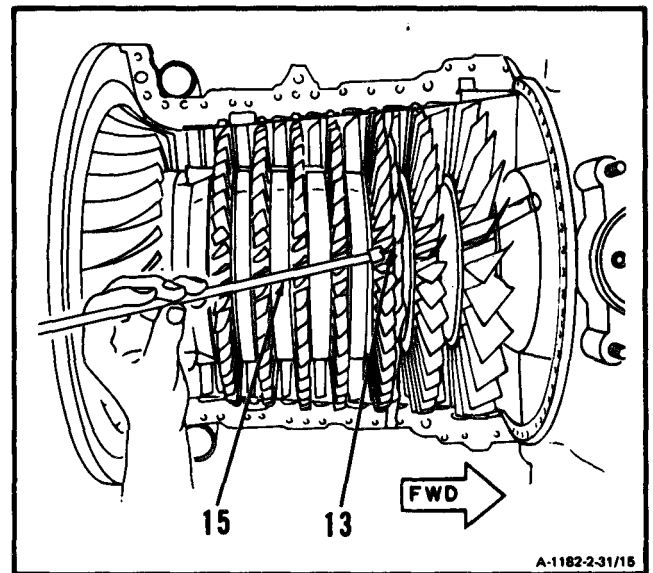

- d. **Tap blade (13) firmly forward.** Use ballpeen hammer.

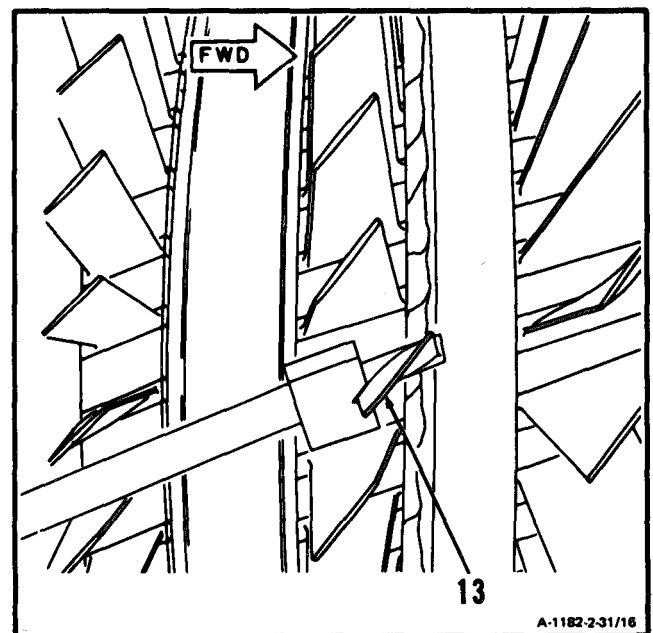

GO TO NEXT PAGE

- e. Continue to tap blade (13) forward until lock-pin (16) is sheared.

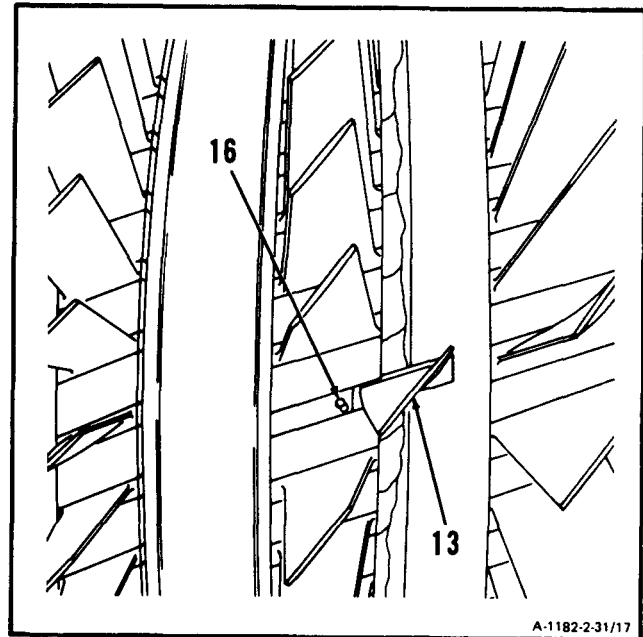

GO TO NEXT PAGE

2-31 REMOVE COMPRESSOR ROTOR BLADES (Continued)

2-31

- f. Move blade (13) forward and **remove sheared lockpin (16)**. Use tweezers (9).

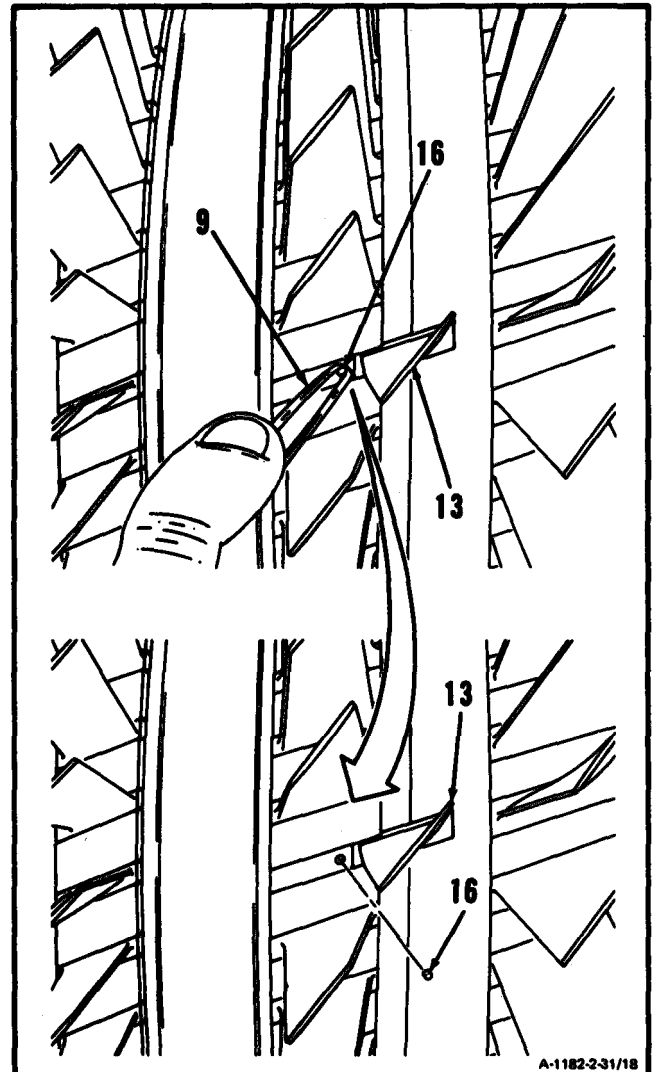

GO TO NEXT PAGE

g. **Remove spring (17),** Use tweezers (9).

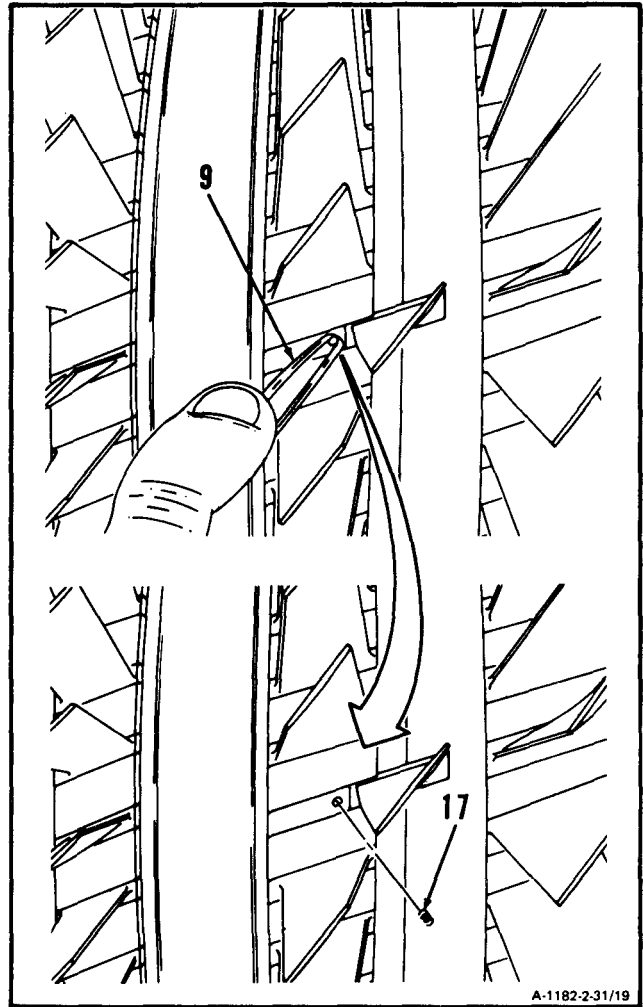

GO TO NEXT PAGE

2-31 REMOVE COMPRESSOR ROTOR BLADES (Continued)

2-31

- h. Remove third stage compressor blade (13).
- i. Remove sheared lockpin (16) from blade.
Use tweezers (9).

**GO TO NEXT PAGE**

CAUTION

Do not remove any parent metal from inside retaining pin hole. Removing material will enlarge hole. If this happens compressor rotor assembly will have to be replaced.

- j. Clean out lockpin hole (18). Use twist drill (12). Remove tape.

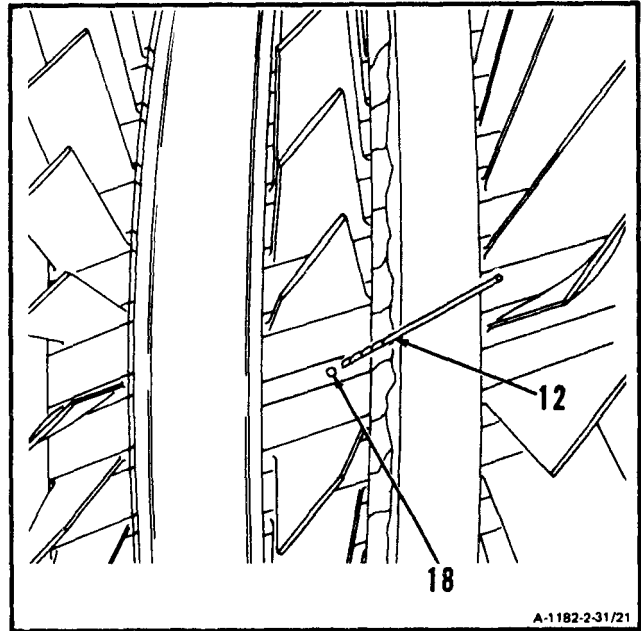

NOTE

Fourth through seventh stage blades shall be removed rearward.

- 3. Remove fourth through seventh stage compressor blades (19) as follows:

NOTE

Procedure to remove fourth through seventh stage blades is the same. Removal of seventh stage blades is shown.

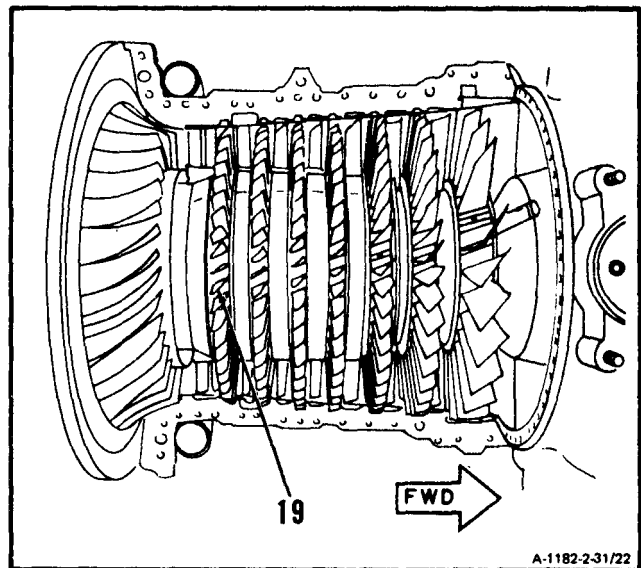

GO TO NEXT PAGE

2-31 REMOVE COMPRESSOR ROTOR BLADES (Continued)

2-31

- a. Twist masking tape (E35) (4), sticky side out. Make the tape 1/2-inch wide.

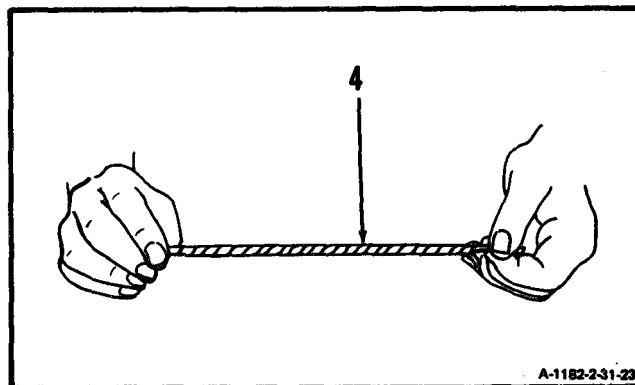

- b. Insert masking tape (E35) (4) into space rearward of seventh stage disc (20).

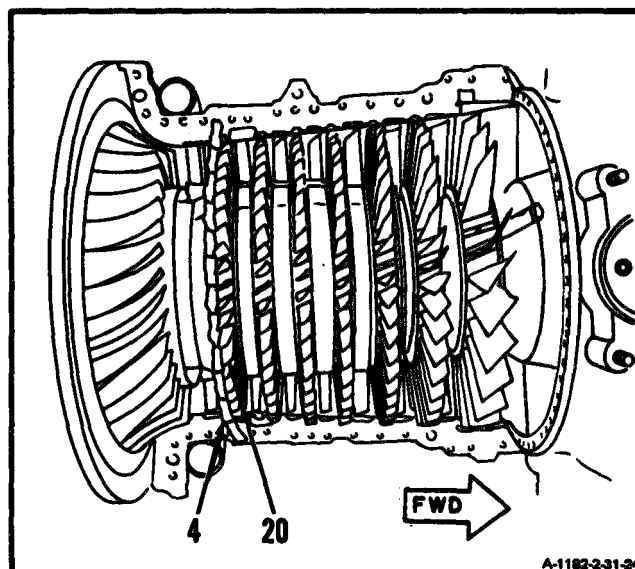

GO TO NEXT PAGE

- c. Position installing tool (T20) (15) forward of blade (19).

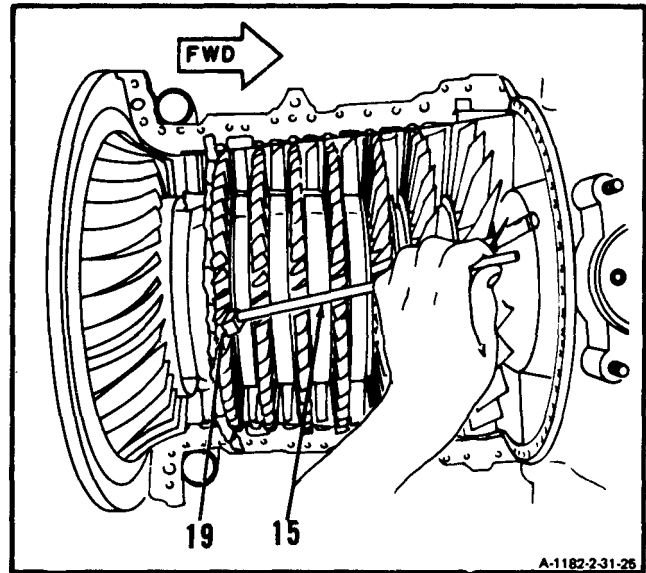

- d. Tap blade (19) firmly rearward. Use ballpeen hammer.

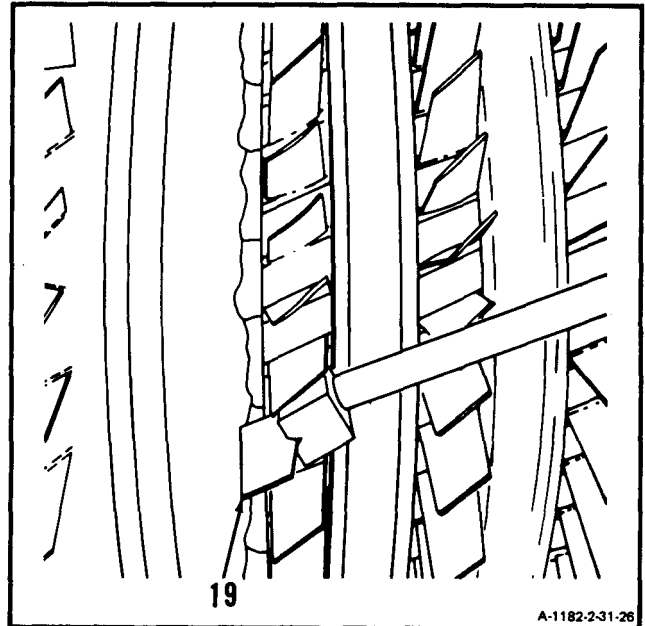

GO TO NEXT PAGE

e. Continue to tap blade (19) rearward until lockpin (21) is sheared.

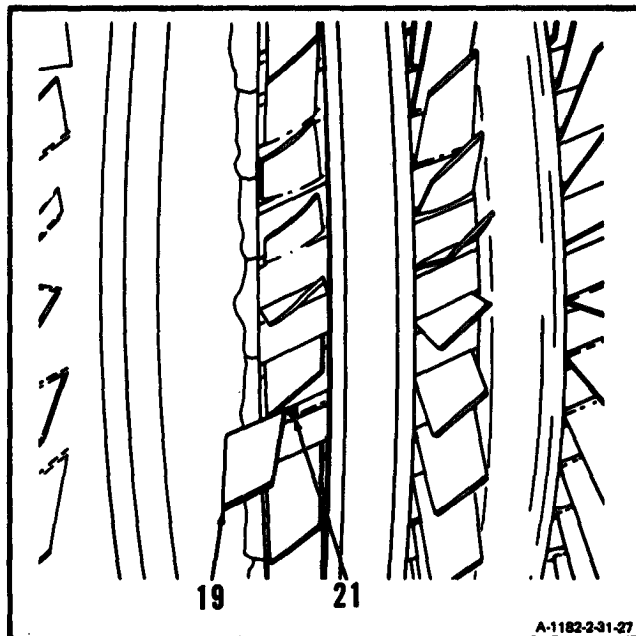

GO TO NEXT PAGE

- f. Move blade (19) rearward and **remove sheared lockpin (21)**. Use tweezers (9).

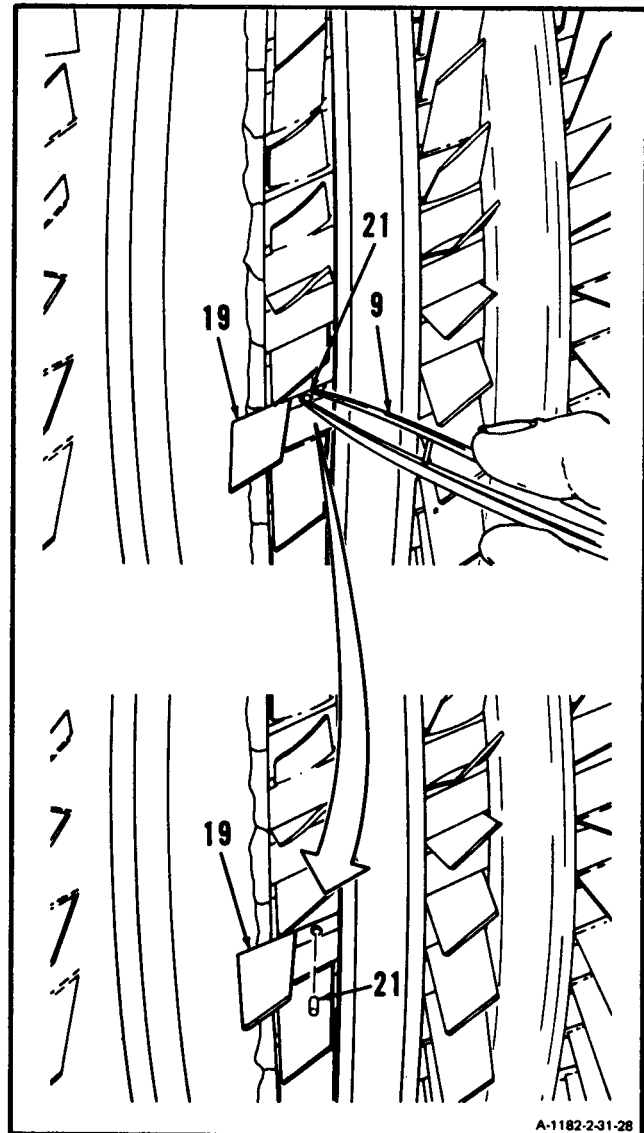

GO TO NEXT PAGE

2-31 REMOVE COMPRESSOR ROTOR BLADES (Continued)

2-31

g. Remove spring (22). Use tweezers (9).

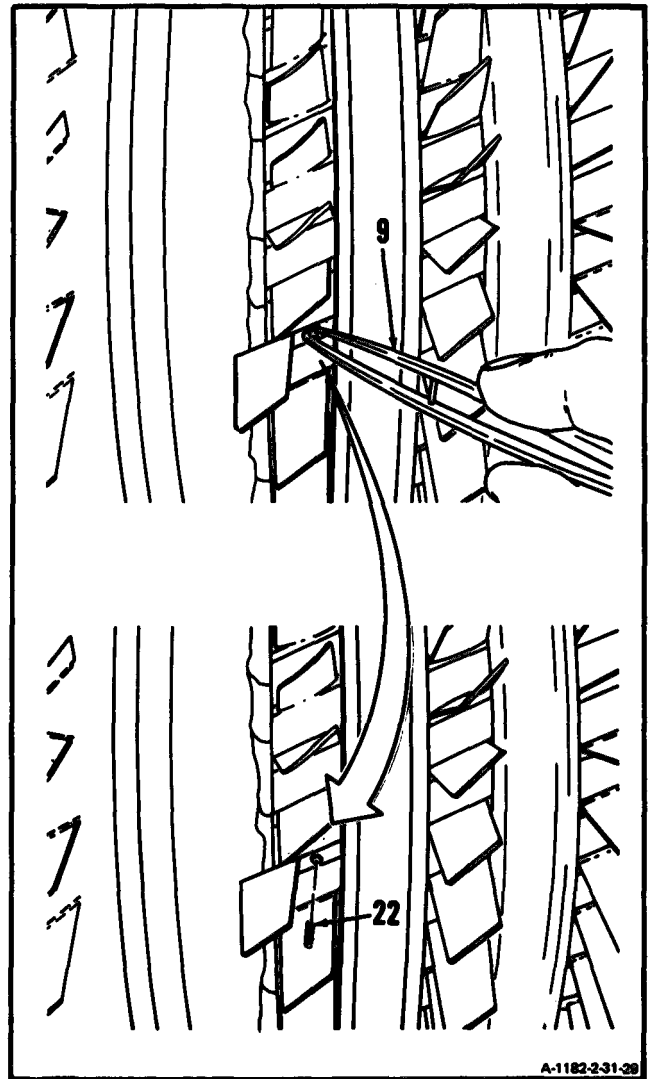

GO TO NEXT PAGE

- h. Remove seventh stage compressor blade (19).
- i. Remove sheared lockpin (21) from blade. Use tweezers (9).

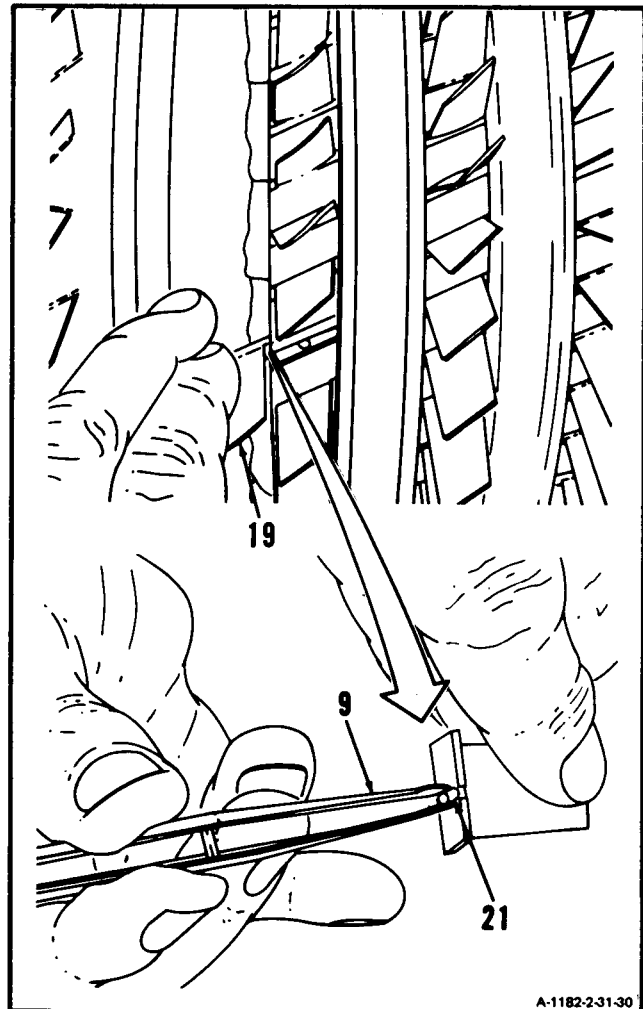

A-1182-2-31-30

GO TO NEXT PAGE

2-31 REMOVE COMPRESSOR ROTOR BLADES (Continued)

2-31

CAUTION

Do not remove any parent metal from inside retaining pin hole. Removing material will enlarge hole. If this happens replace compressor rotor assembly.

- j. Clean out lockpin hole (22). Use twist drill (12). Remove tape.

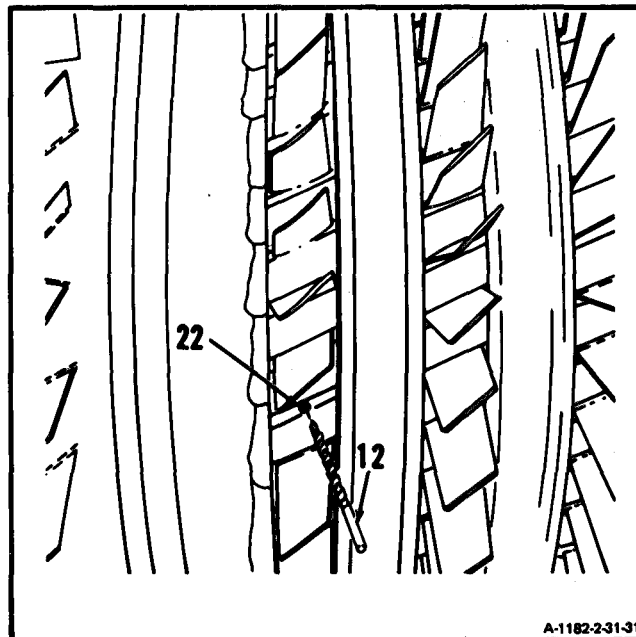

FOLLOW-ON MAINTENANCE:

None

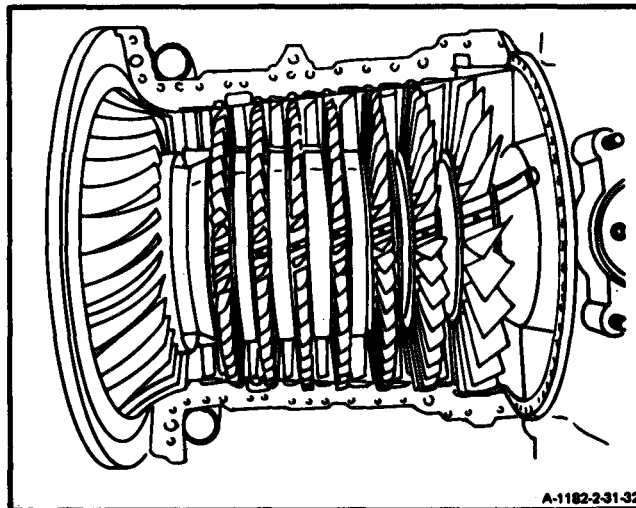

END OF TASK

INITIAL SETUP**Applicable Configurations:**

All

Tools:

None

Materials:

Dry Cleaning Solvent (E17)

Gloves (E20)

Lint-Free Cloth (E26)

Personnel Required:

68B10 Aircraft Powerplant Repairer

Equipment Condition:

Engine Oil System Drained (Task 1-75)

Oil Cooler Assembly Removed (Task 8-5)

In-Line Fuel Filter Assembly Removed

(Task 6-36)

Ignition Exciter Removed (Task 7-11)

Oil Filler Assembly and Oil Filler Strainer
Removed (Task 8-16)

Starter Drive Assembly Removed (Task 5-12)

Main Fuel Filter and Bracket Removed
(Task 6-29)Interstate Air-Bleed Actuator Removed
(Task 2-1)

Compressor Bleed Band Removed (Task 2-9)

Upper Compressor Housing Removed
(Task 2-19)**General Safety Instructions:****WARNING**

Dry cleaning solvent (E17) is flammable and toxic. It can irritate skin and cause burns. Use only in well-ventilated area, away from heat and open flame. In case of contact, immediately flush skin or eyes with water for at least 15 minutes. Get medical attention for eyes.

GO TO NEXT PAGE

1. Wear gloves (E20) and **clean compressor rotor blades (1)**. Use lint-free cloth (E26) dampened in dry cleaning solvent (E17).
2. **Wipe dry**. Use clean, dry lint-free cloth (E26).

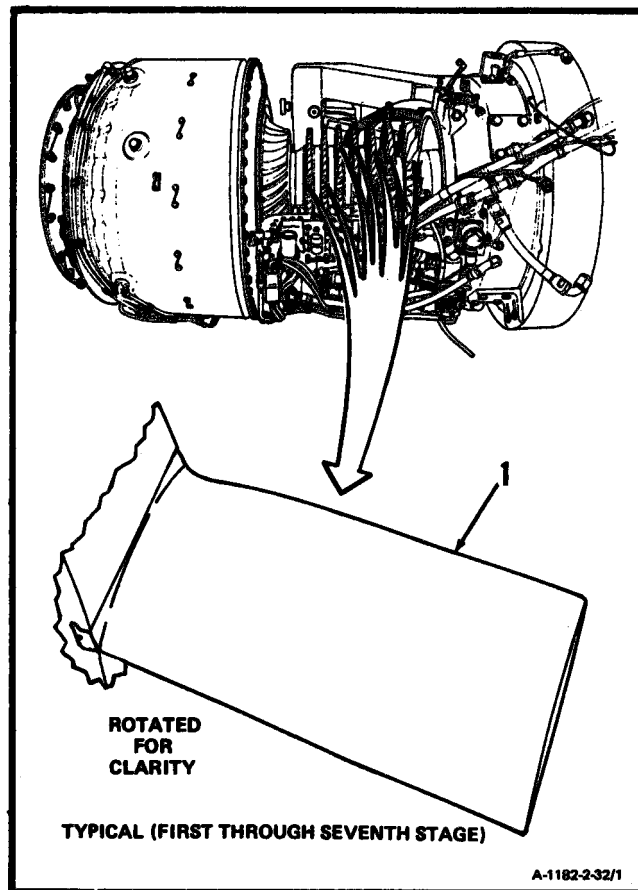

GO TO NEXT PAGE

3. Wear gloves (E20). **Clean centrifugal impeller (2).** Use lint-free cloth (E26) dampened in dry cleaning solvent (E17).
4. **Wipe dry.** Use clean, dry lint-free cloth (E26).

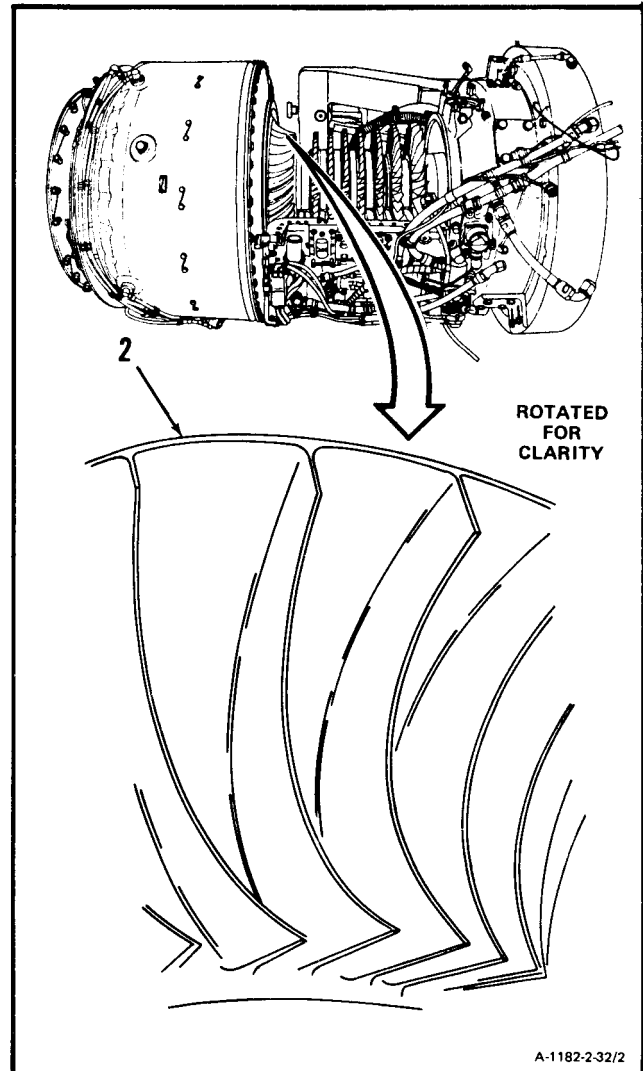
**FOLLOW-ON MAINTENANCE:**

Inspect Compressor Rotor Blades (Task 2-33).

END OF TASK

2-33 INSPECT COMPRESSOR ROTOR BLADES

2-33

INITIAL SETUP

Materials:
None

Applicable Configurations:
All

Personnel Required:
68B30 Aircraft Powerplant Inspector

Tools:
Technical Inspection Tool Kit,
NSN 5180-00-323-5114

Equipment Condition:
Upper Compressor Housing Removed (Task 2-19)

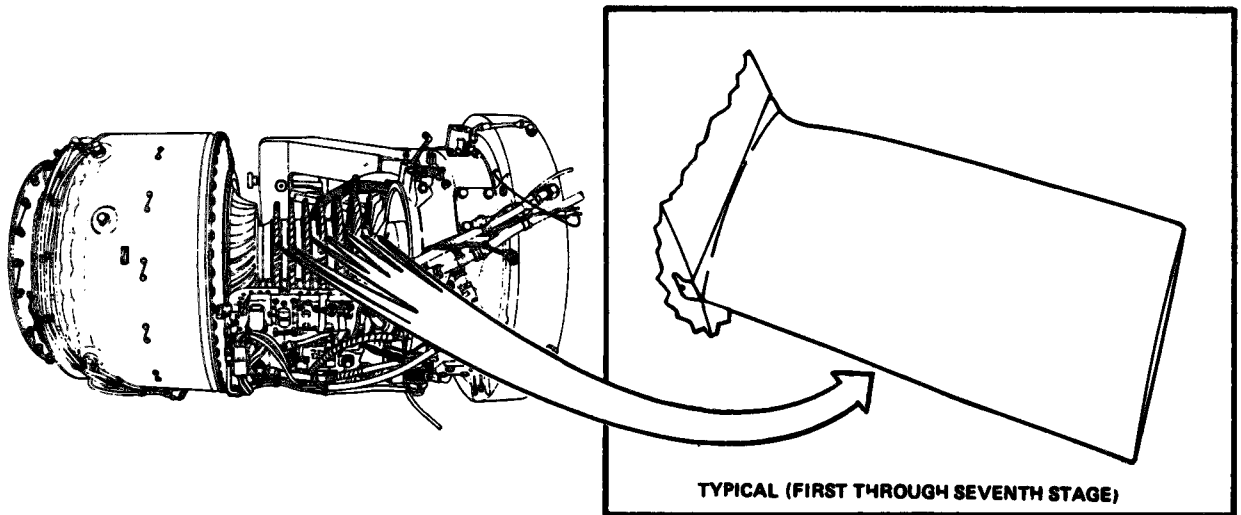

A-1182-233/1

GO TO NEXT PAGE

1. **Inspect first stage compressor rotor blades (1)** as follows:

- a. There shall be no cracks.
- b. There shall be no bends or distortion.
- c. There shall be no corrosion pitting.
- d. There shall be no surface nicks (2) or dents (3) greater than:
 - (1) 0.015 inch in depth.
 - (2) 0.350 inch in length.

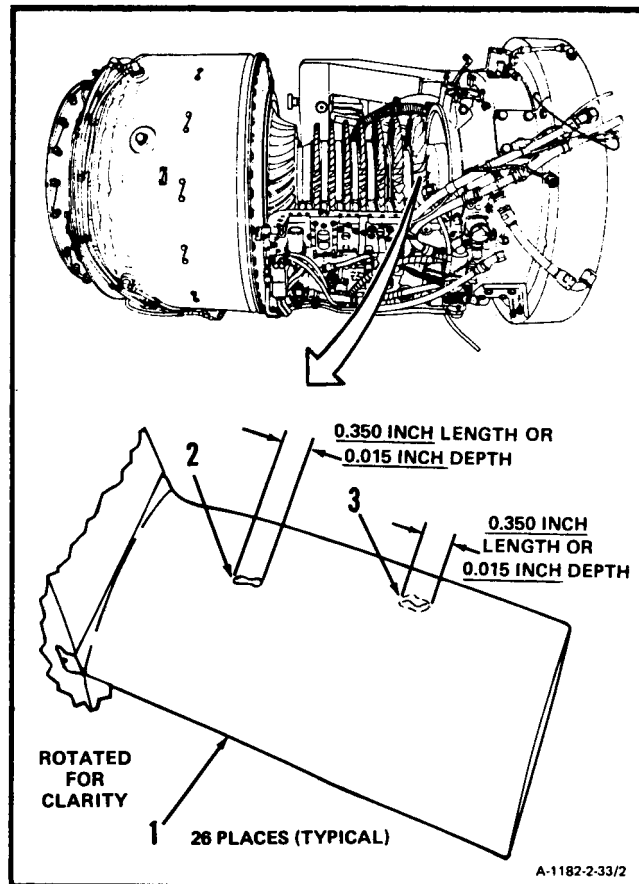

e. **Inspect blade tip (4)** as follows:

- (1) There shall be no nicks or dents (5) deeper than 0.060 inch.

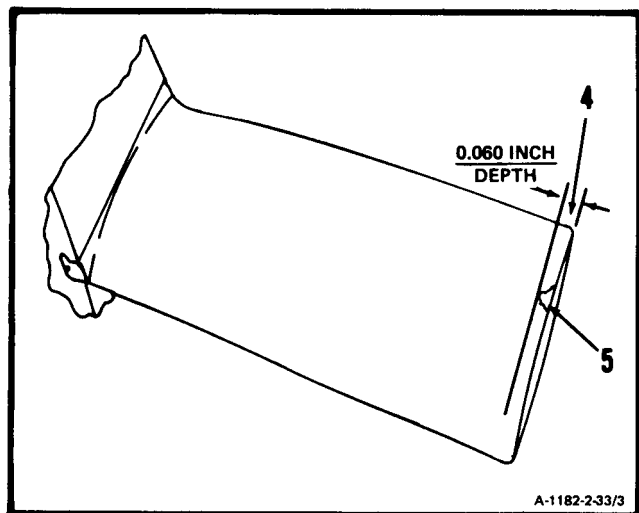

GO TO NEXT PAGE

2-33 INSPECT COMPRESSOR ROTOR BLADES (Continued)

2-33

- f. Inspect for leading edge material rollover resulting from erosion. Minor rollover is allowed if within repairable limits. Refer to Task 2-34. Leading edge rollover can be detected by running a fingernail along airfoil on convex side until edge is contacted.

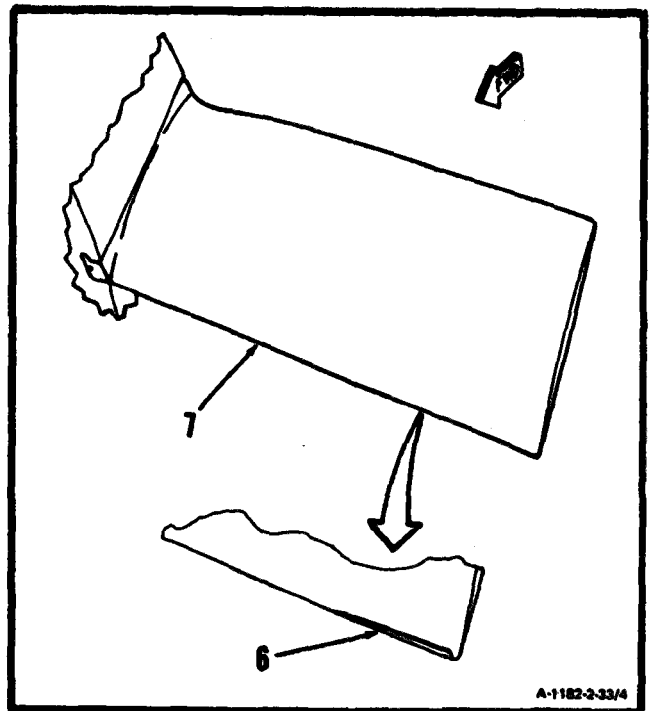

- g. Inspect critical area (8) as follows:

NOTE

No repair is allowed within the critical area (8).

- (1) There shall be no nicks.
- (2) Smooth dents (9) are permitted except on leading and trailing edges provided they do not exceed 0.030 inch in diameter and/or 0.010 inch in depth. These dents (9) must not have sharp edges (11). Minor sand and dust peening (10) is acceptable on leading edge.

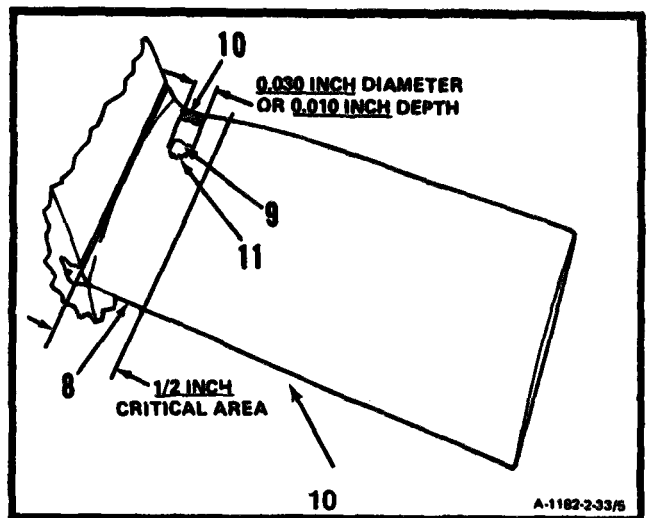

GO TO NEXT PAGE

- h. Inspect area between 0.500 inch and 1.125 inches above blade root (12). There shall be no nicks or dents (13) in edges (7 and 14) deeper than 0.025 inch.

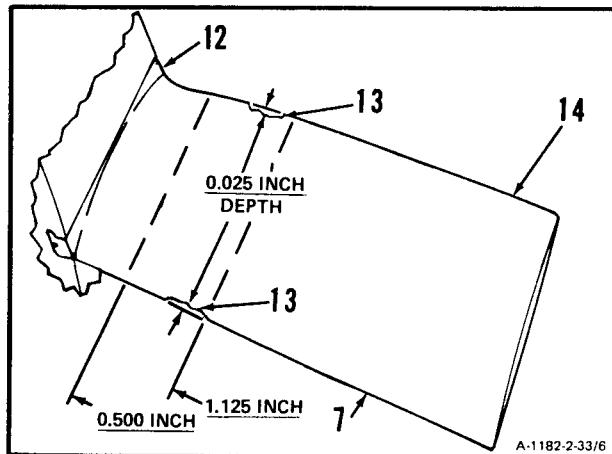

- i. Inspect area between 1.125 inches and 1.750 inches above blade root (12). There shall be no nicks or dents (15) in edges (7 and 14) deeper than 0.050 inch.

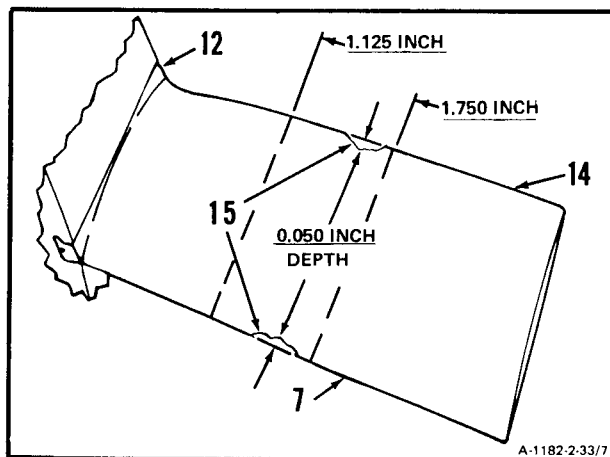

- j. Inspect area between 1.750 inches and 2.375 inches above blade root (12). There shall be no nicks or dents (16) in edges (7 and 14) deeper than 0.075 inch.

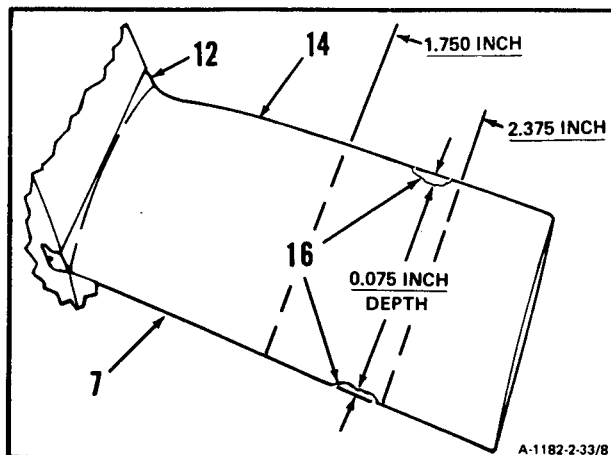

2-33 INSPECT COMPRESSOR ROTOR BLADES (Continued)2-33

k. Inspect area between 2.375 inches above blade root (12) and blade tip (4). There shall be no nicks or dents (17) in edges (7 and 14) deeper than 0.100 inch.

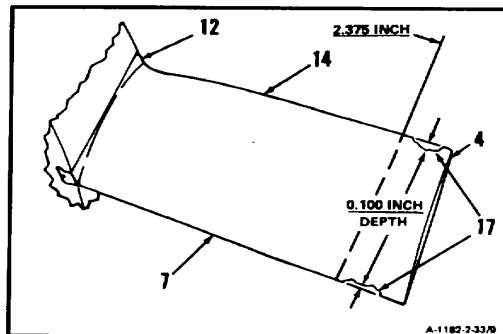

l. Inspect leading edge of first stage compressor blades for erosion. Erosion shall be within limits shown.

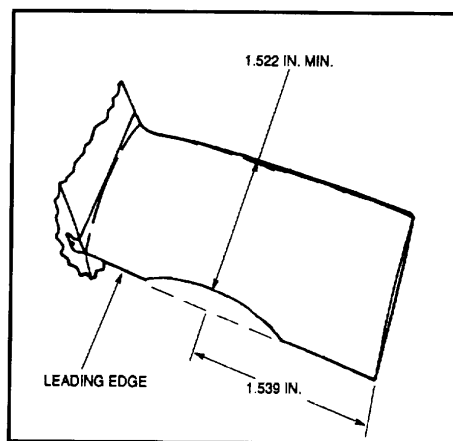

GO TO NEXT PAGE

2-33 INSPECT COMPRESSOR ROTOR BLADES (Continued)2-33

- m. Inspect tip of 2nd through 7th stage compressor blades for erosion. Using a 6 inch scale measure dimension "A" at blade tip. Blades with dimension "A" less than shown below shall be replaced.

COMPRESSOR STAGEDIA "A" (INCHES)

2	0.919
3	0.704
4 THROUGH 7	0.562

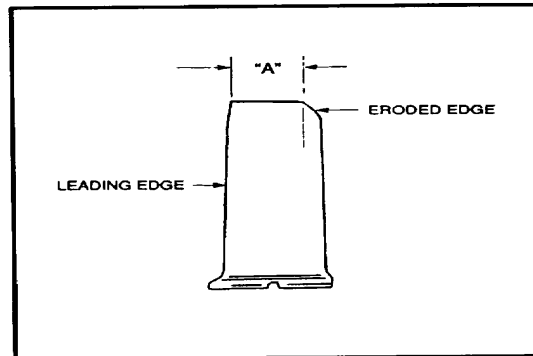

- 2. Inspect second stage compressor rotor blades (18) as follows:
 - a. There shall be no cracks.
 - b. There shall be no bends or distortion.
 - c. There shall be no corrosion pitting.
 - d. There shall be no surface nicks (19) or dents (20) greater than:
 - (1) 0.015 inch in depth.
 - (2) 0.350 inch in length.

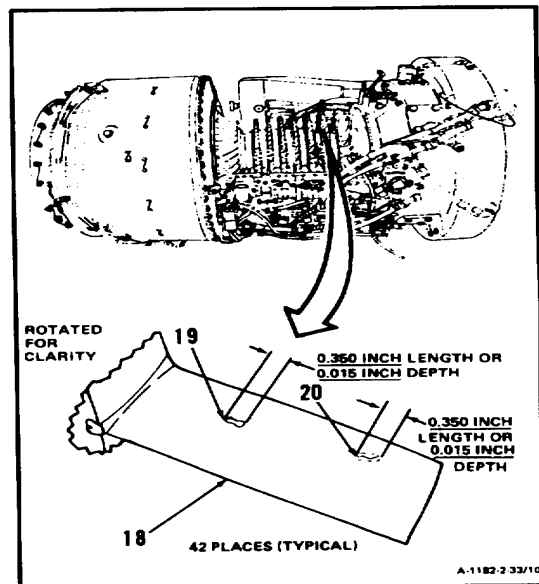

GO TO NEXT PAGE

2-33 INSPECT COMPRESSOR ROTOR BLADES (Continued)

e. Inspect blade tip (21) as follows:

(1) There shall be no nicks or dents (22) deeper than 0.060 inch.

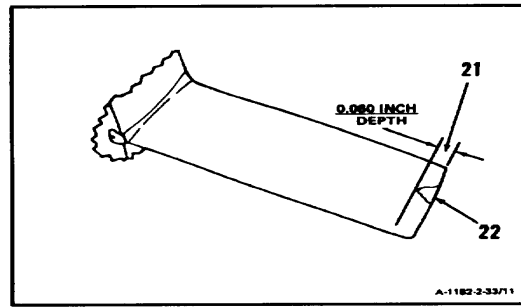

f. There shall be no material rollover (23) on forward surface at blade leading edge (24). Use fingernail to detect rollover.

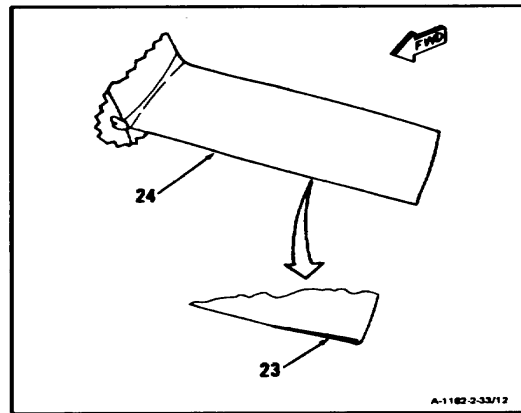

GO TO NEXT PAGE

a. Inspect critical area (25) as follows:

- (1) There shall be no nicks.
- (2) There shall be no surface dents (26) or sand and dust peening (27) deeper than 0.010 inch or wider than 0.030 inch diameter. These dents (26) must not have sharp edges (28).

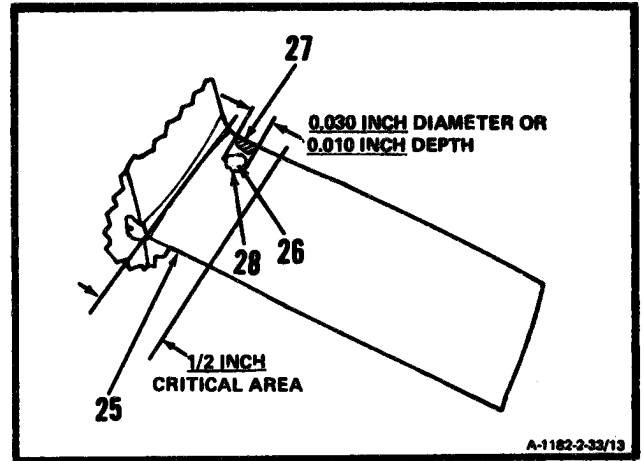

- h. Inspect area between 0.500 inch and 1.000 inches above blade root (29). There shall be no nicks or dents (30) in edges (24 and 31) deeper than 0.015 inch.

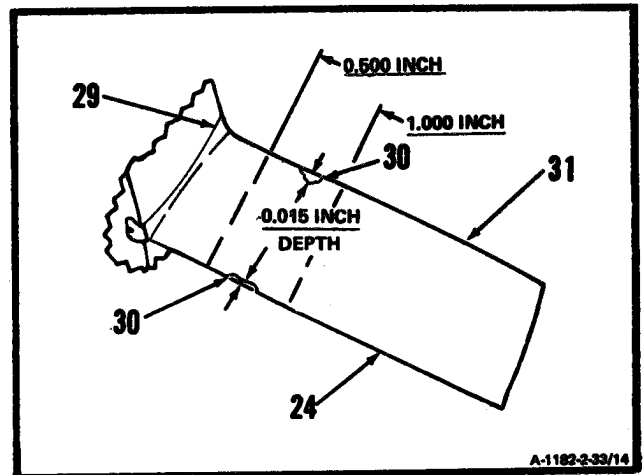

Inspect area between 1.000 inches and 1.500 inches above blade root (29). There shall be no nicks or dents (32) in edges (24 and 31) deeper than 0.030 inch.

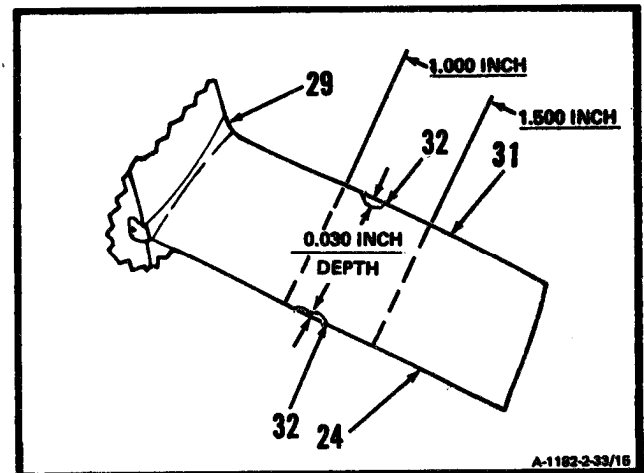

GO TO NEXT PAGE

- j. Inspect area between 1.500 inches and 2.000 inches above blade root (29). There shall be no nicks or dents (33) in edges (24 and 31) deeper than 0.045 inch.

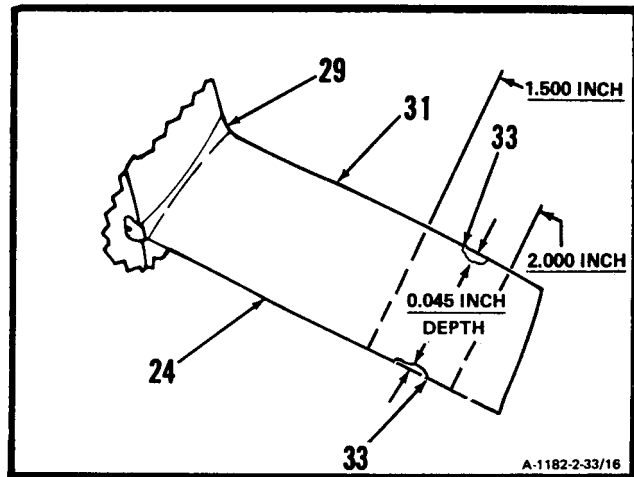

- k. Inspect area between 2.000 inches above blade root (29) and blade tip (21). There shall be no nicks or dents (34) in edges (24 and 31) deeper than 0.060 inch.

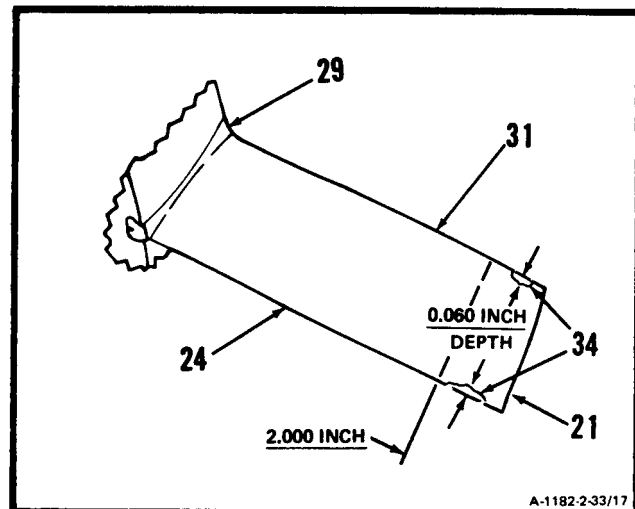

GO TO NEXT PAGE

2-33 INSPECT COMPRESSOR ROTOR BLADES (Continued)

2-33

3. Inspect third stage compressor rotor blades (35) as follows:

- a. There shall be no cracks.
- b. There shall be no bends or distortion.
- c. There shall be no corrosion pitting.
- d. There shall be no surface nicks (36) or dents (37) greater than:
 - (1) 0.015 inch in depth.
 - (2) 0.350 inch in length.

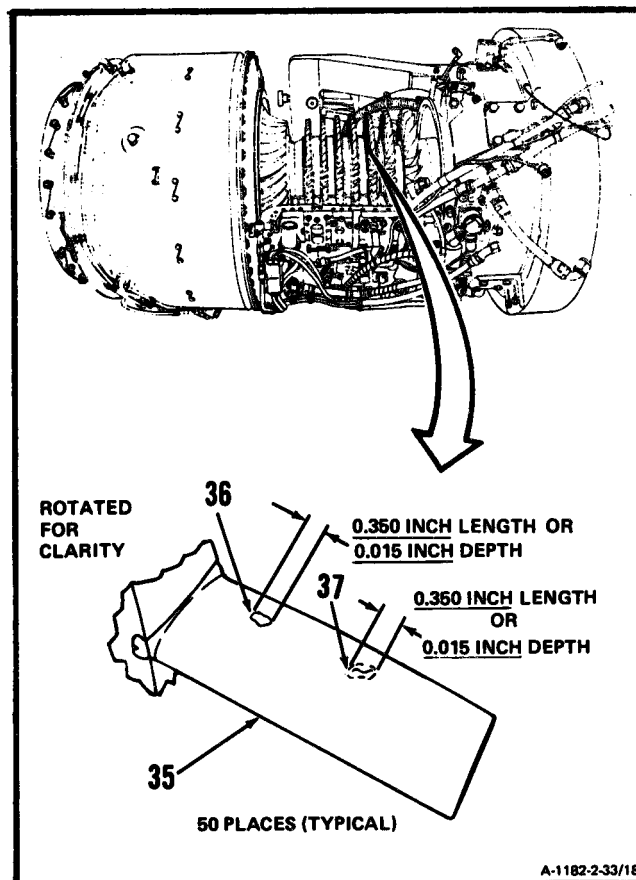

e. Inspect blade tip (38) as follows:

- (1) There shall be no nicks or dents (39) deeper than 0.060 inch.

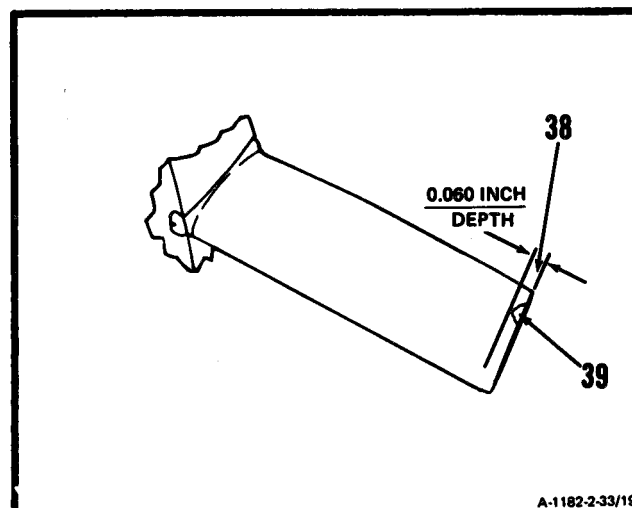

GO TO NEXT PAGE

- f. There shall be no material rollover (40) on forward surface at blade leading edge (41). Use fingernail to detect rollover.

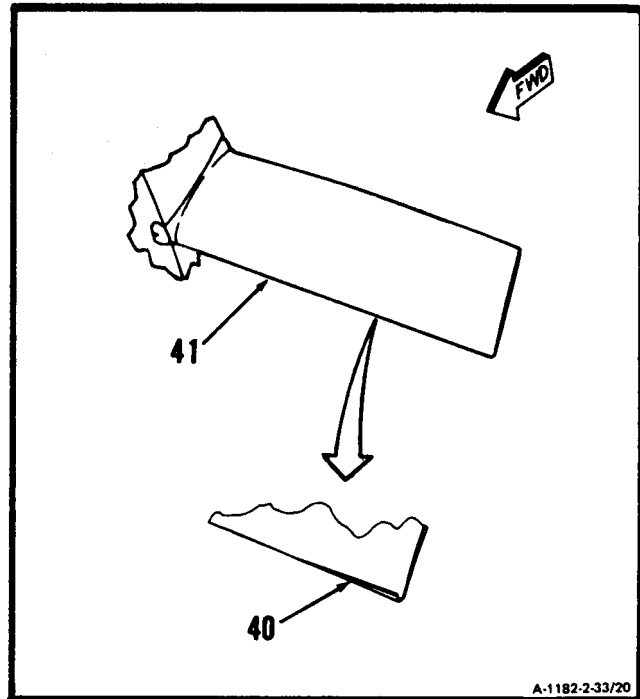

- g. **Inspect critical area (42)** as follows:

- (1) There shall be no nicks.
- (2) There shall be no surface dents (43) or sand and dust peening (44) deeper than 0.010 inch or wider than 0.030 inch diameter. These dents (43) must not have sharp edges (45).

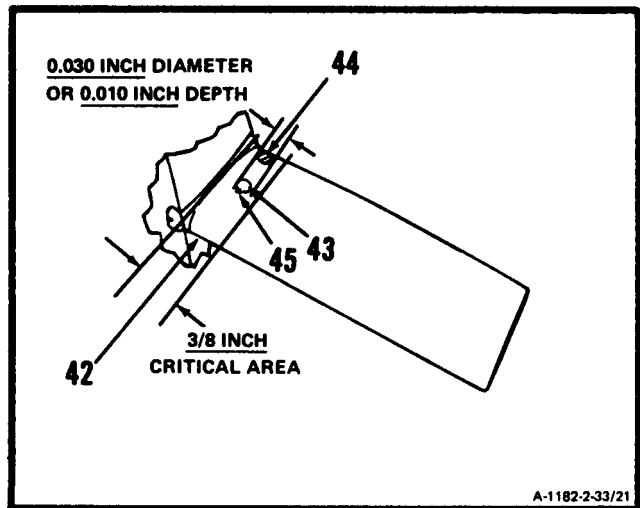

GO TO NEXT PAGE

- h. Inspect area between 0.375 inch and 0.875 inch above blade root (46). There shall be no nicks or dents (47) in edges (41 and 48) deeper than 0.015 inch.

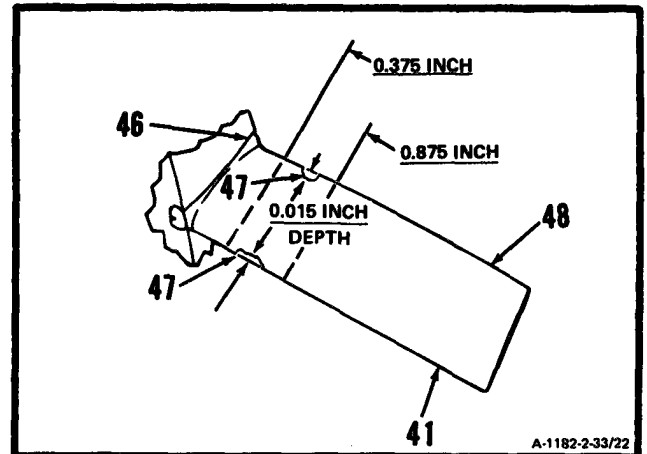

- i. Inspect area between 0.875 inch and 1.375 inches above blade root (46). There shall be no nicks or dents (49) in edges (41 and 48) deeper than 0.030 inch.

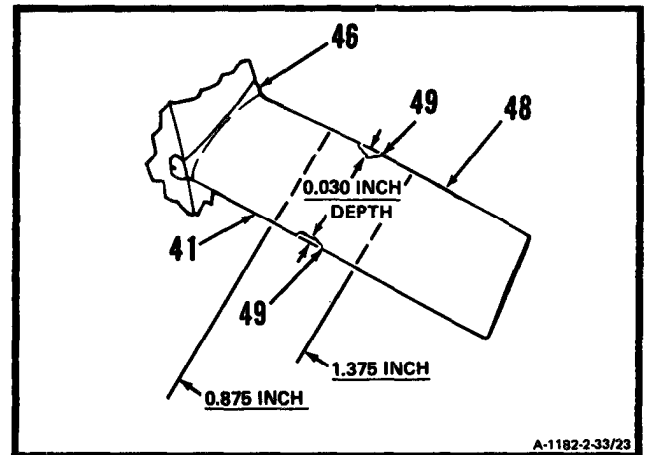

Inspect area between 1.375 inches and 1.875 inches above blade root (46). There shall be no nicks or dents (50) in edges (41 and 48) deeper than 0.045 inch.

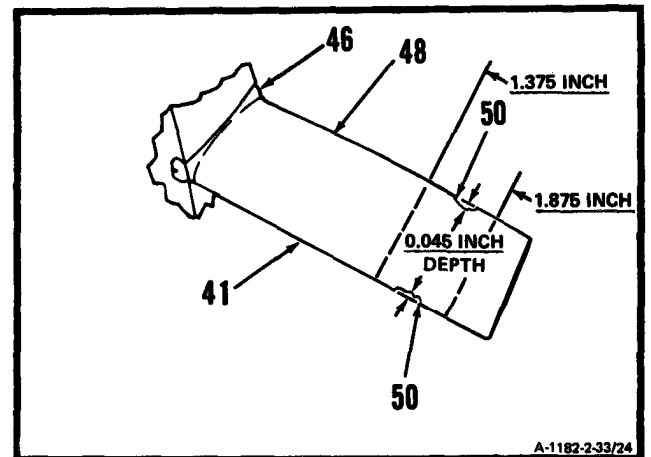

GO TO NEXT PAGE

- k. Inspect area between 1.875 inches above blade root (46) and blade tip (38). There shall be no nicks or dents (51) in edges (41 and 48) deeper than 0.060 inch.

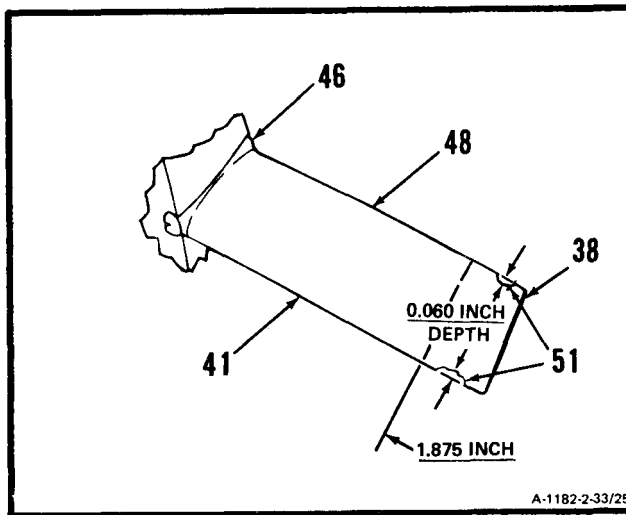

Inspect fourth stage compressor rotor blades (52) as follows:

- a. There shall be no cracks.
- b. There shall be no bends or distortion.
- c. There shall be no corrosion pitting.
- d. There shall be no surface nicks (53) or dents (54) greater than:
 - (1) 0.015 inch in depth.
 - (2) 0.350 inch in length.

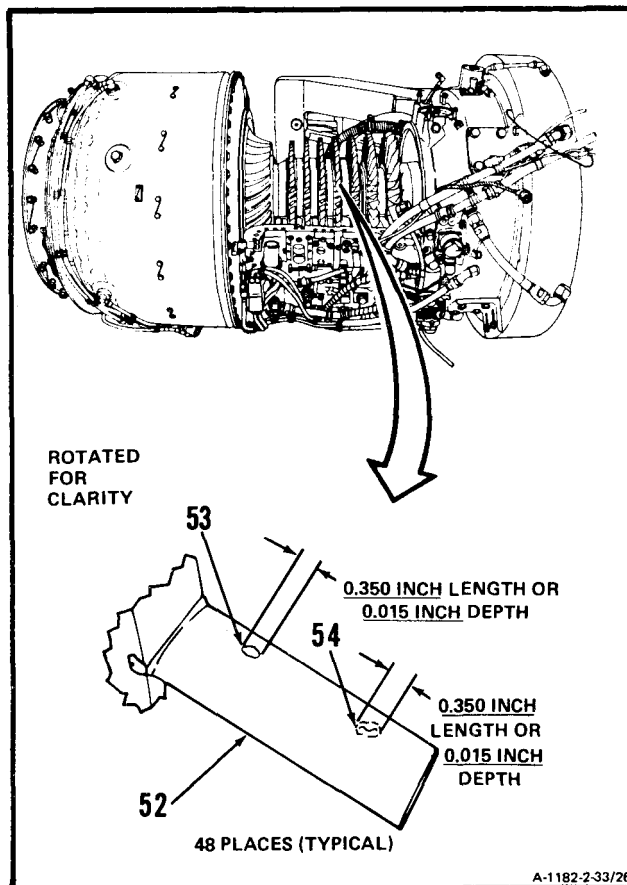

GO TO NEXT PAGE

e. **Inspect blade tip (55)** as follows:

- (1) There shall be no nicks or dents (56) deeper than 0.060 inch.

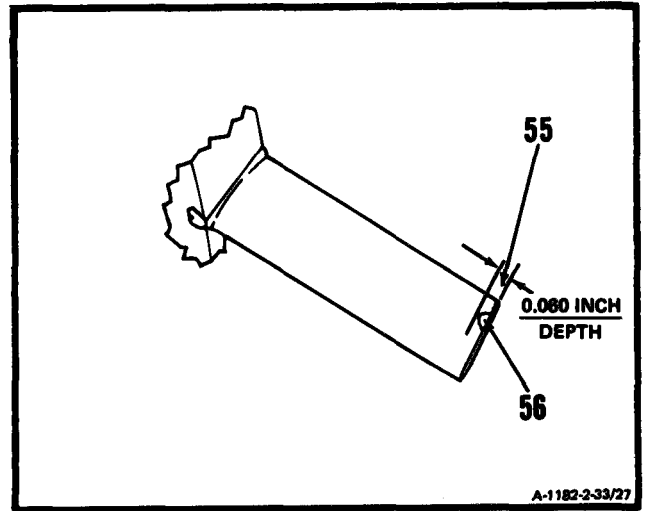

- f. There shall be no material rollover (57) on forward surface at blade leading edge (58). Use fingernail to detect rollover.

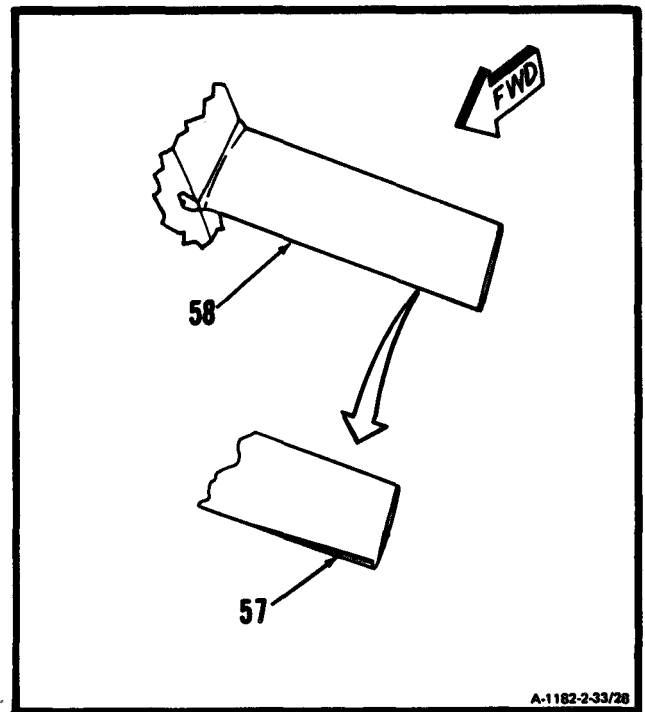

GO TO NEXT PAGE

g. Inspect critical area (59) as follows:

- (1) There shall be no nicks.
- (2) There shall be no surface dents (60) or sand and dust peening (61) deeper than 0.010 inch or wider than 0.030 inch diameter. These dents (60) must not have sharp edges (62).

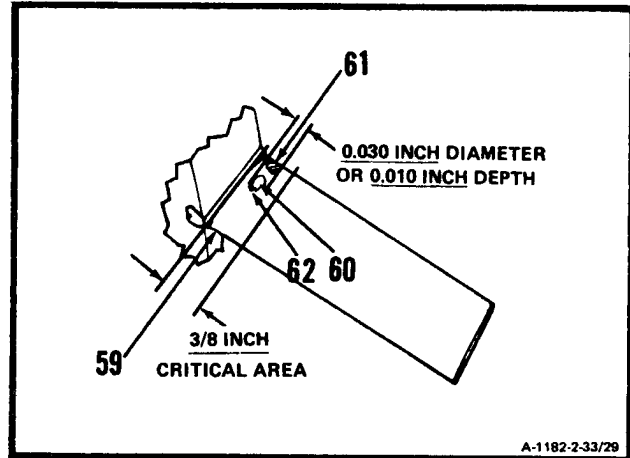

h. Inspect area between 0.375 inch and 0.422 inch above blade root (63). There shall be no nicks or dents (64) in edges (58 and 65) deeper than 0.015 inch.

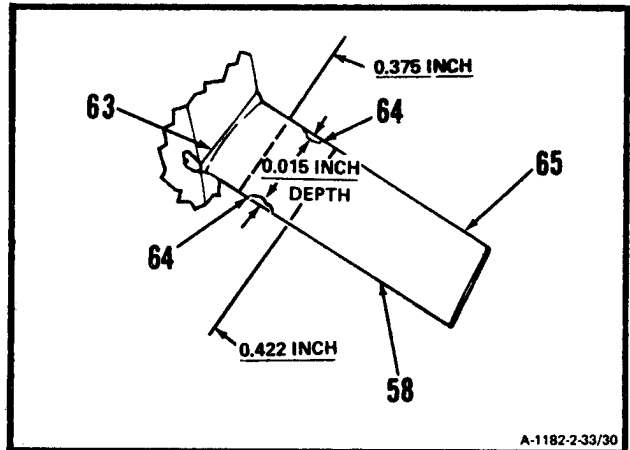

i. Inspect area between 0.422 inch and 0.797 inch above blade root (63). There shall be no nicks or dents (66) in edges (58 and 65) deeper than 0.030 inch.

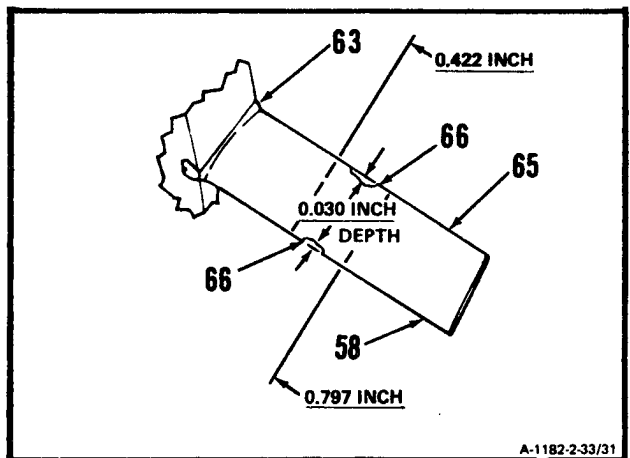

GO TO NEXT PAGE

2-33 INSPECT COMPRESSOR ROTOR BLADES (Continued)

2-33

- j. Inspect area between 0.797 inch and 1.219 inches above blade root (63). There shall be no nicks or dents (67) in edges (58 and 65) deeper than 0.045 inch.

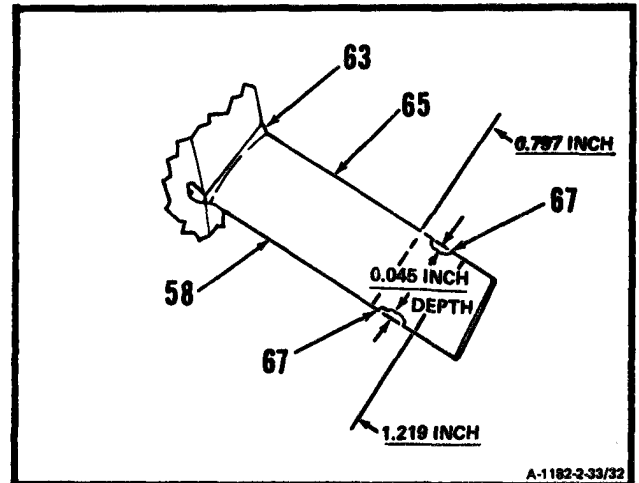

- k. Inspect area between 1.219 inches above blade root (63) and blade tip (55). There shall be no nicks or dents (68) in edges (58 and 65) deeper than 0.060 inch.

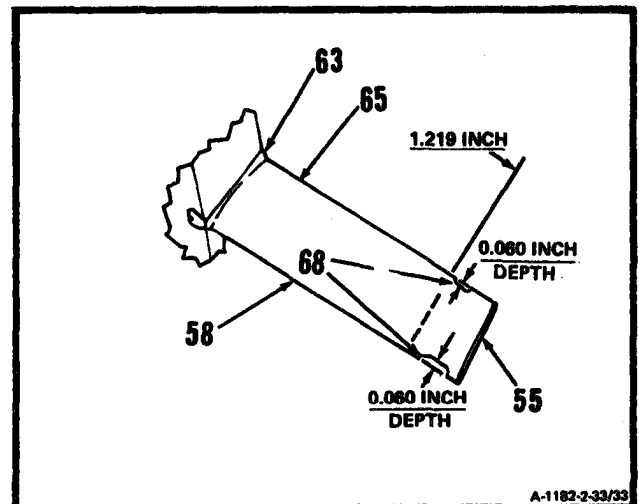

GO TO NEXT PAGE

5. Inspect fifth stage compressor rotor blades (69)

as follows:

- a. There shall be no cracks.
- b. There shall be no bends or distortion.
- c. There shall be no corrosion pitting.
- d. There shall be no surface nicks (70) or dents (71) greater than:
 - (1) 0.015 inch in depth.
 - (2) 0.350 inch in length.

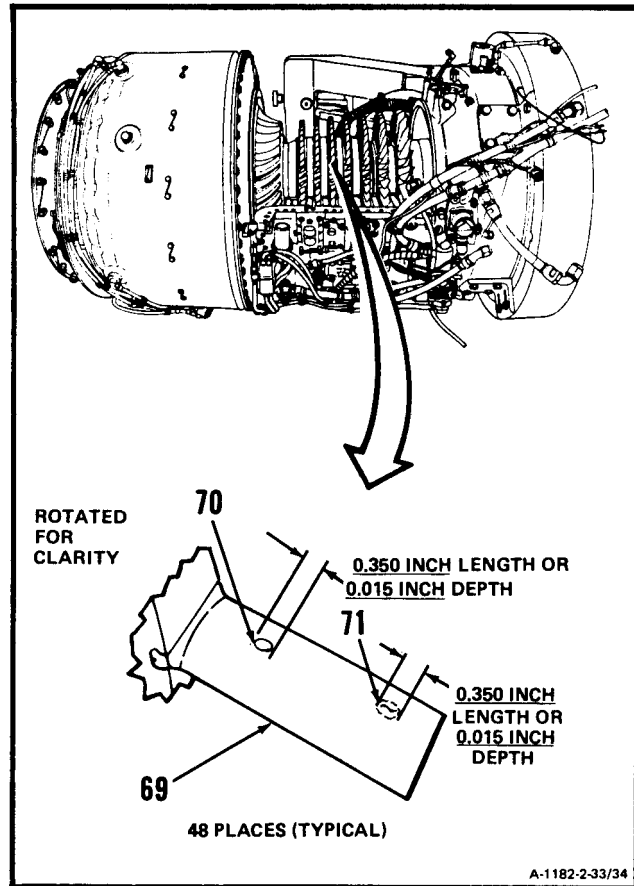

e. Inspect blade tip (72) as follows:

- (1) There shall be no nicks or dents (73) deeper than 0.060 inch.

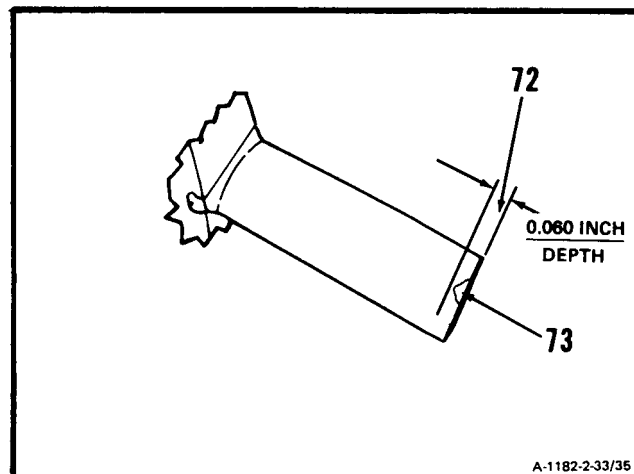

GO TO NEXT PAGE

- f. There shall be no material rollover (74) on forward surface at blade leading edge (75). Use fingernail to detect rollover.

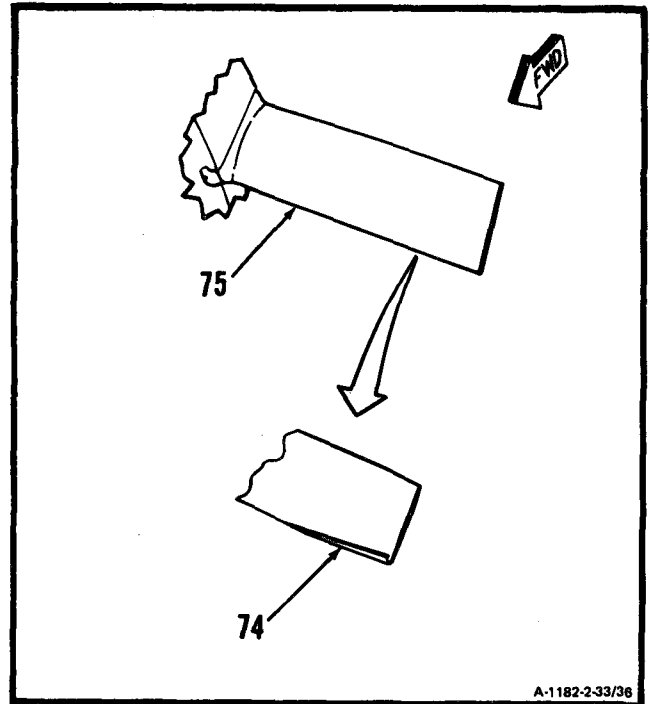

- g. Inspect critical area (76) as follows:

- (1) There shall be no nicks.
- (2) There shall be no surface dents (77) or sand and dust peening (78) deeper than 0.010 inch or wider than 0.030 inch diameter. These dents (77) must not have sharp edges (79).

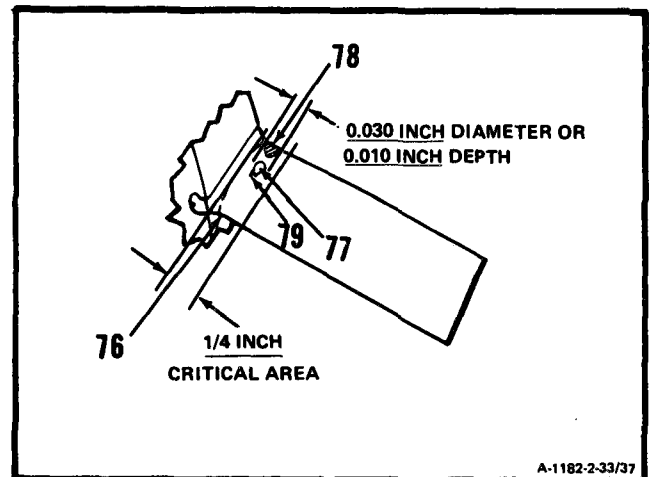

GO TO NEXT PAGE

- h. Inspect area between 0.250 inch and 0.641 inch above blade root (80). There shall be no nicks or dents (81) in edges (75 and 82) deeper than 0.015 inch.

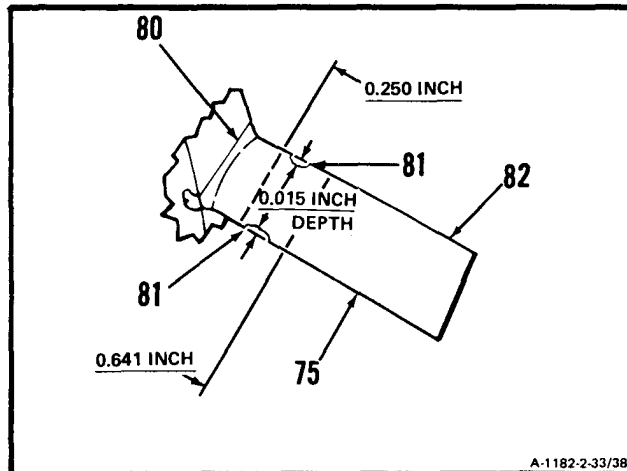

- i. Inspect area between 0.641 inch and 1.031 inches above blade root (80). There shall be no nicks or dents (83) in edges (75 and 82) deeper than 0.030 inch.

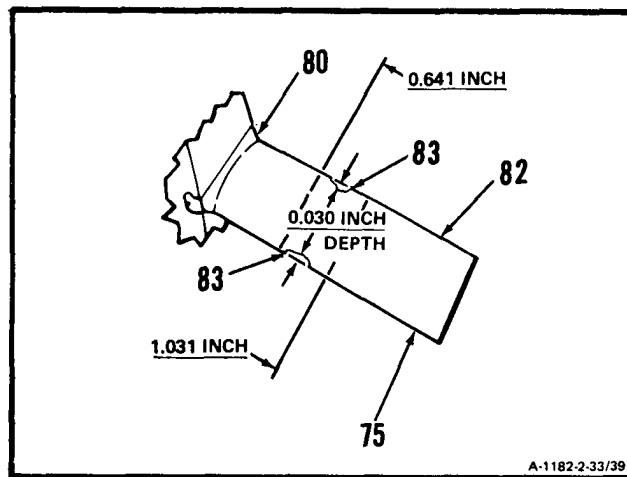

- j. Inspect area between 1.031 inches and 1.031 inches above blade root (80). There shall be no nicks or dents (84) in edges (75 and 82) deeper than 0.045 inch.

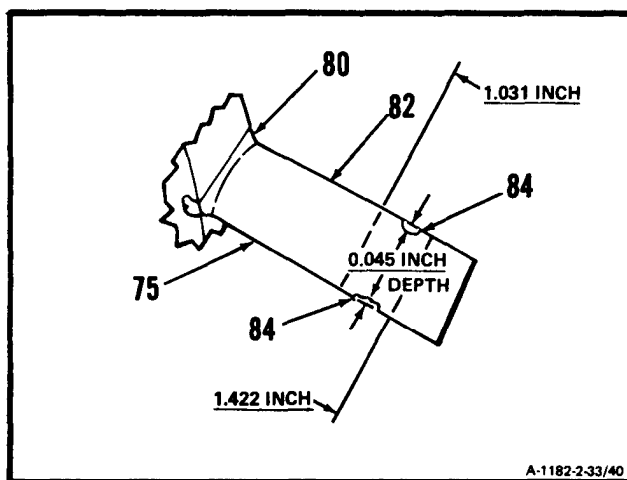

GO TO NEXT PAGE

- k. Inspect area between 1.422 inches above blade root (80) and blade tip (72). There shall be no nicks or dents (85) in edges (75 and 82) deeper than 0.080 inch.

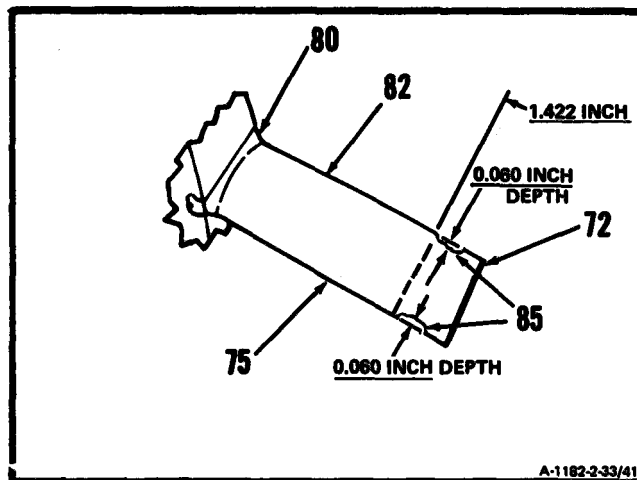

6. Inspect sixth stage compressor rotor blades (86) as follows:

- a. There shall be no cracks.
- b. There shall be no bends or distortion,
- c. There shall be no corrosion pitting.
- d. There shall be no surface nicks (87) or dents (88) greater than:
 - (1) 0.015 inch in depth.
 - (2) 0.350 inch in length.

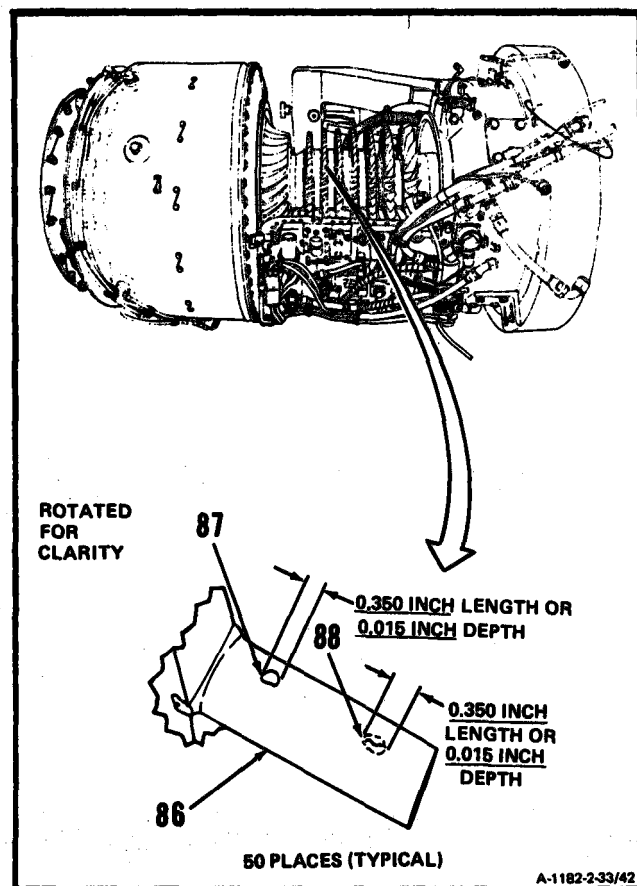

GO TO NEXT PAGE

e. Inspect blade tip (89) as follows:

- (1) There shall be no nicks or dents (90) deeper than 0.060 inch.

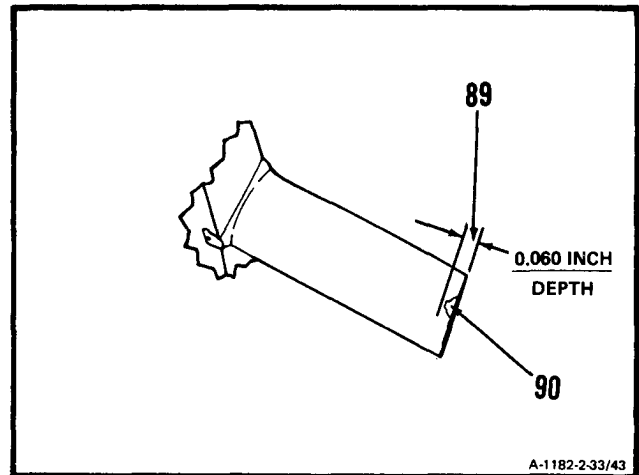

f. There shall be no material rollover (91) on forward surface at blade leading edge (92). Use fingernail to detect rollover.

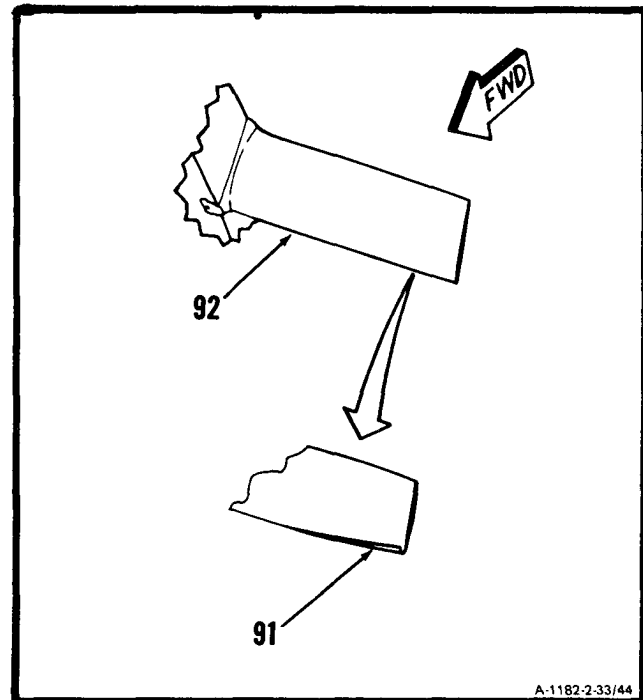

GO TO NEXT PAGE

g. Inspect critical area (93) as follows:

- (1) There shall be no nicks.
- (2) There shall be no surface dents (94) or sand and dust peening (95) deeper than 0.010 inch or wider than 0.030 inch diameter. These dents (94) must not have sharp edges (96).

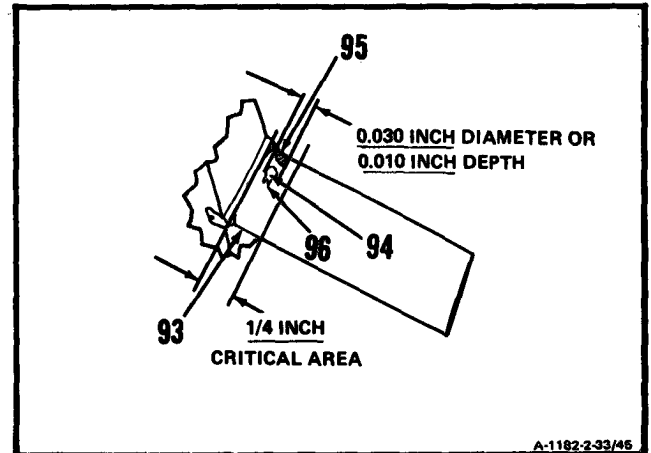

h. Inspect area between 0.250 inch and 0.625 inch above blade root (97). There shall be no nicks or dents (98) in edges (92 and 99) deeper than 0.015 inch.

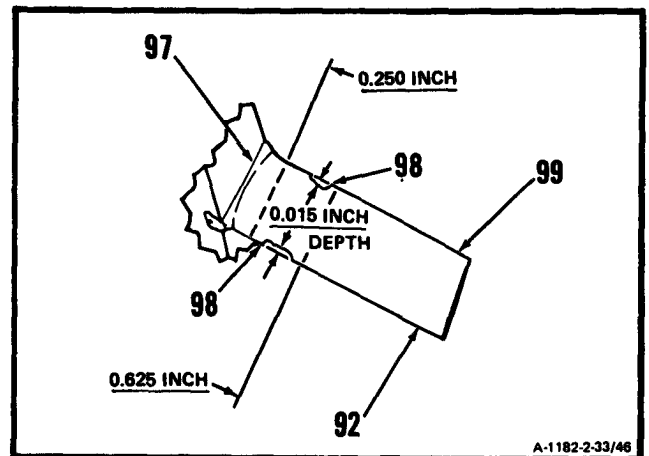

i. Inspect area between 0.625 inch and 1.000 inches above blade root (97). There shall be no nicks or dents (100) in edges (92 and 99) deeper than 0.030 inch.

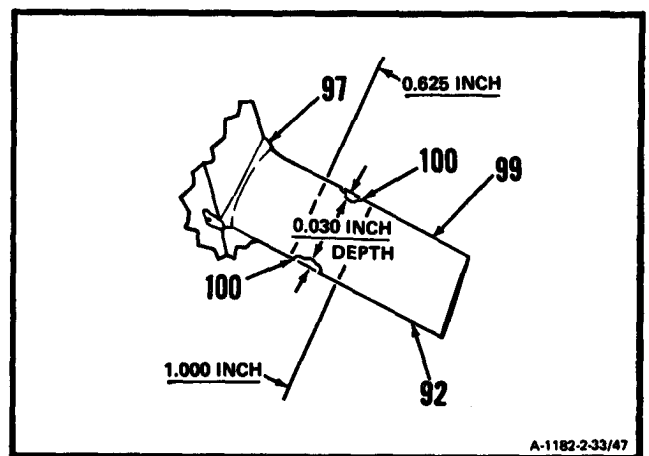

GO TO NEXT PAGE

- j. Inspect area between 1.000 inches and 1.375 inches above blade root (97). There shall be no nicks or dents (101) in edges (92 and 99) deeper than 0.045 inch.

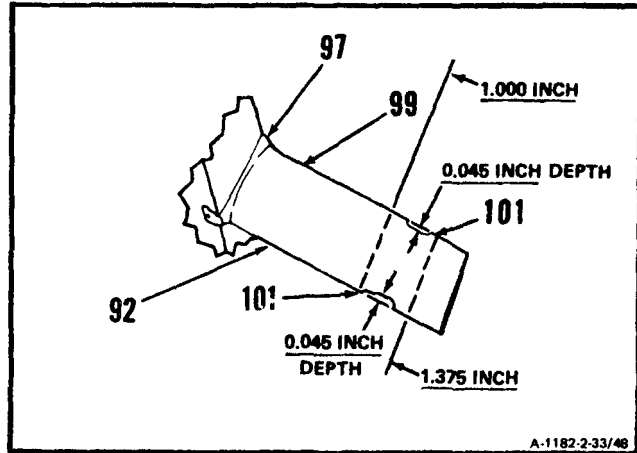

- k. Inspect area between 1.375 inches above blade root (97) and blade tip (89). There shall be no nicks or dents (102) in edges (92 and 99) deeper than 0.060 inch.

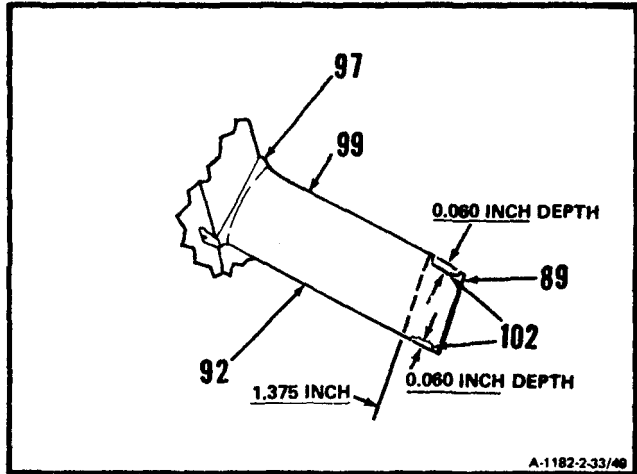

GO TO NEXT PAGE

7. Inspects stage compressor rotor blades (103) as follows:

- a. There shall be no cracks.
- b. There shall be no bends or distortion.
- c. There shall be no corrosion pitting.
- d. There shall be no surface nicks (104) or dents (105) greater than:
 - (1) 0.015 inch in depth.
 - (2) 0.350 inch in length.

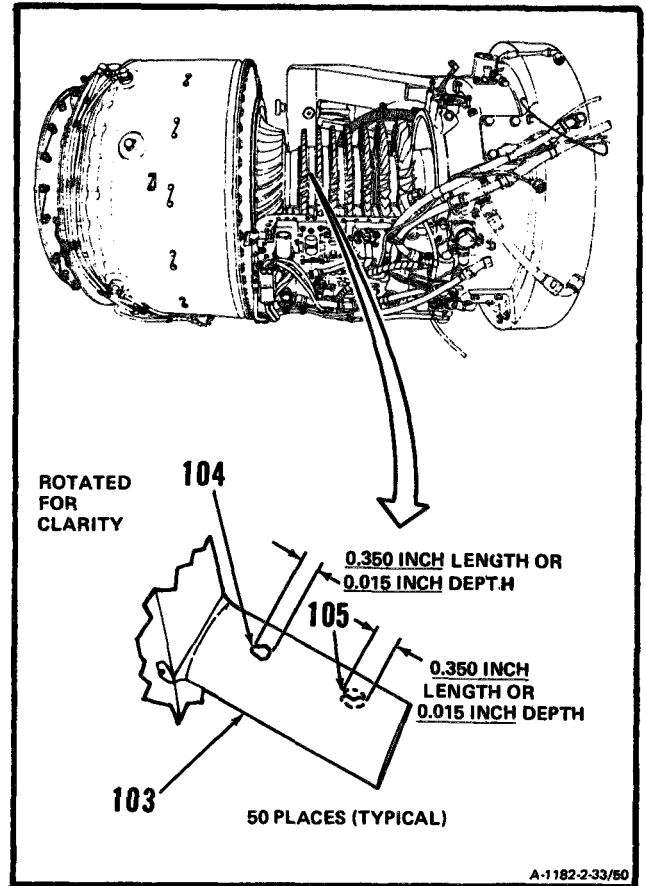

e. Inspect blade tip (106) as follows:

- (1) There shall be no nicks or dents (107) deeper than 0.060 inch.

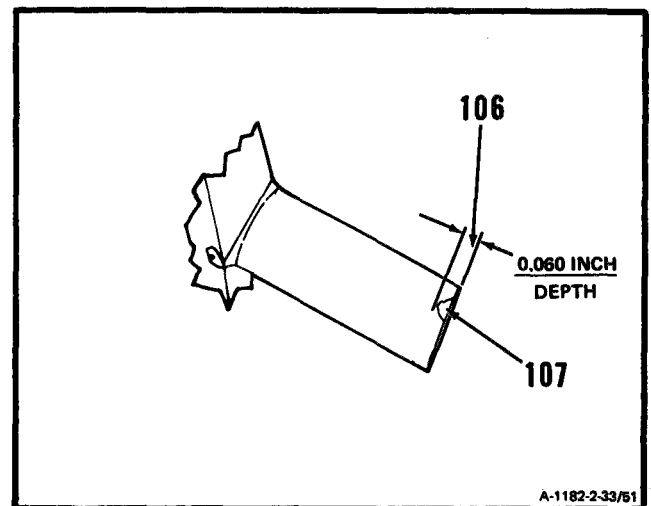

GO TO NEXT PAGE

- f. There shall be no material rollover (108) on forward surface at blade leading edge (109). Use fingernail to detect rollover.

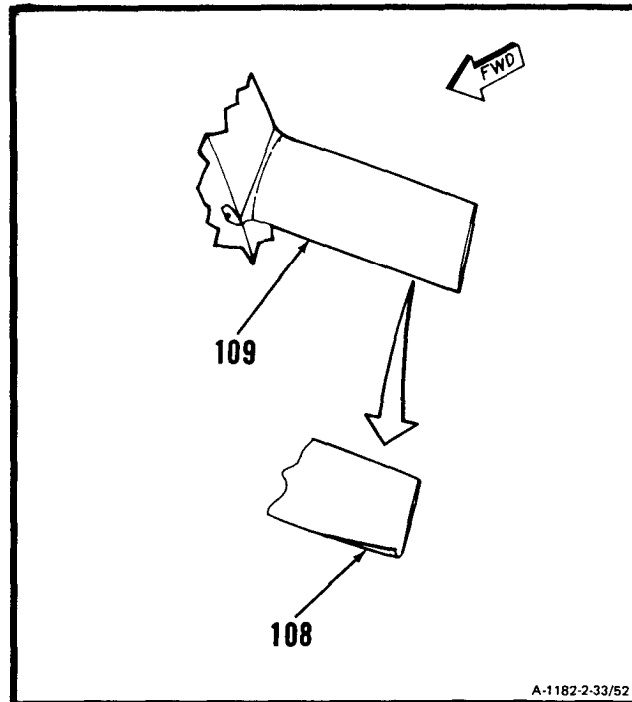

- g. Inspect critical area (110) as follows:

- (1) There shall be no nicks.
- (2) There shall be no surface dents (111) or sand and dust peening (112) deeper than 0.010 inch or wider than 0.030 inch diameter. These dents (111) must not have sharp edges (113).

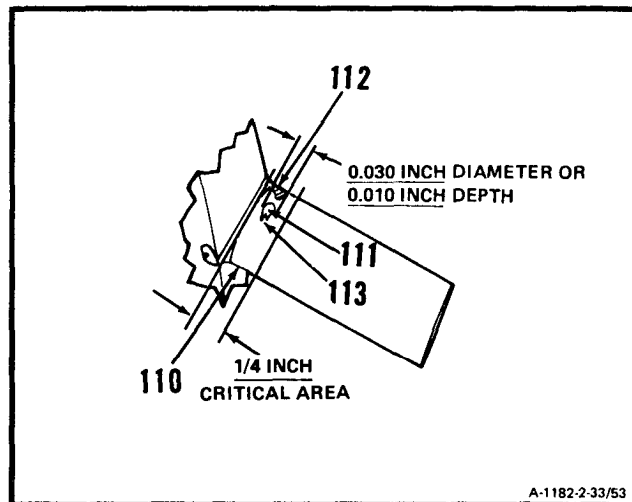

GO TO NEXT PAGE

- h. Inspect area between 0.250 inch and 0.594 inch above blade root (114). There shall be no nicks or dents (115) in edges (109 and 116) deeper than 0.015 inch.

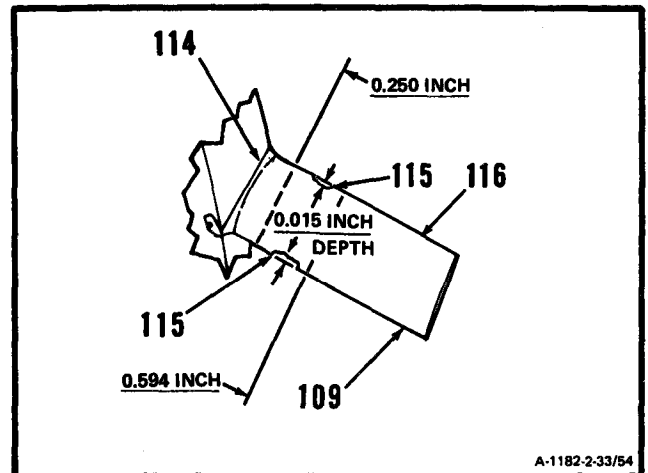

- i. Inspect area between 0.594 inch and 0.938 inch above blade root (114). There shall be no nicks or dents (117) in edges (109 and 116) deeper than 0.030 inch.

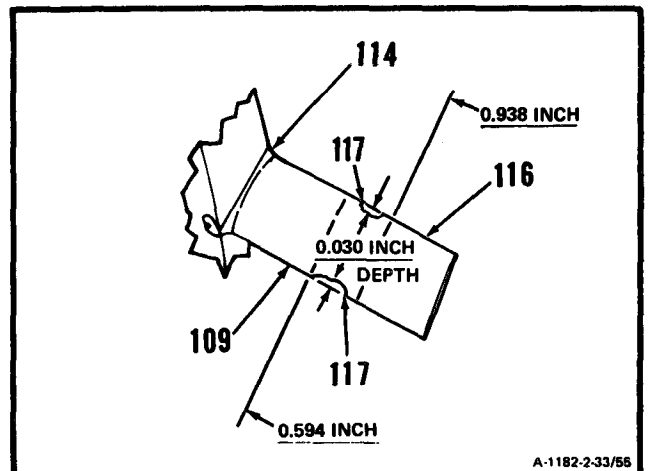

- j. Inspect area between 0.938 inch and 1.281 inches above blade root (114). There shall be no nicks or dents (118) in edges (109 and 116) deeper than 0.045 inch.

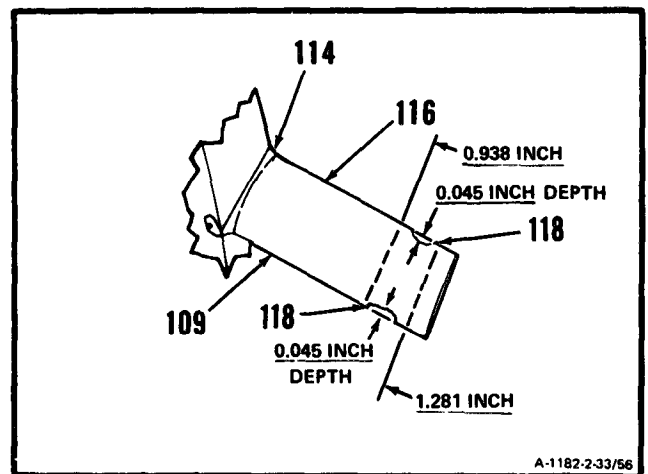

GO TO NEXT PAGE

- k. Inspect area between 1.281 inches above blade root (114) and blade tip (106). There shall be no nicks or dents (119) in edges (109 and 116) deeper than 0.060 inch.

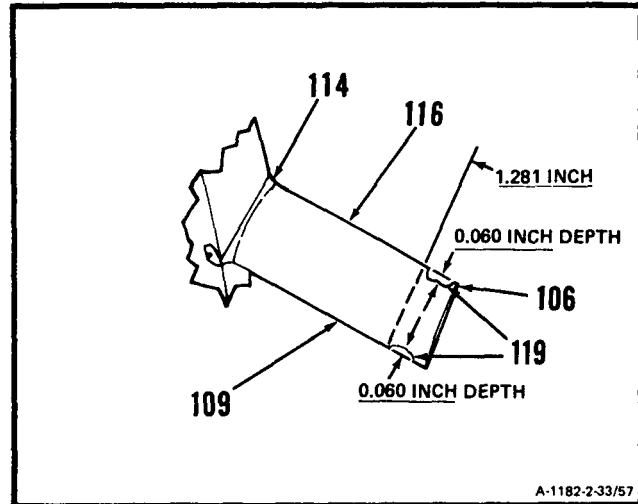

GO TO NEXT PAGE

8. Inspect centrifugal impeller (120) as follows:

- a. **Inspect critical area (121).** There shall be no cracks or nicks. There shall be no bends or distortion. There shall be no dents with sharp edges. There shall be no smooth-edged dents (122) deeper than 0.010 inch or larger than 0.030 inch in diameter.

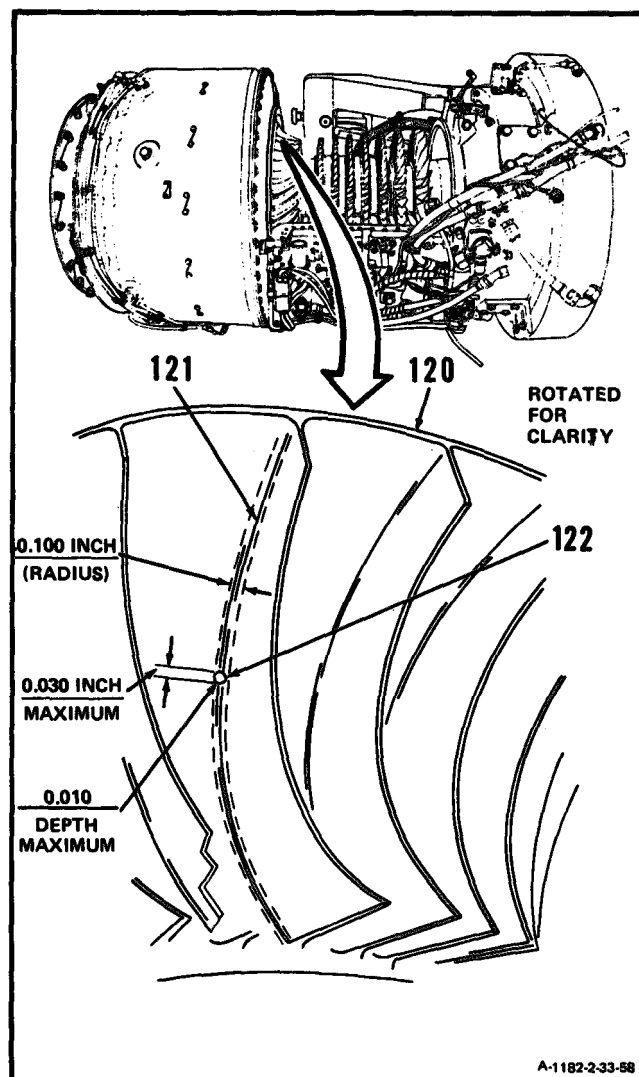

GO TO NEXT PAGE

b. **Inspect leading edge (123).** There shall be no cracks. There shall be no bends or distortion. There shall be no nicks or dents (124) deeper than 0.100 inch or longer than 0.300 inch. These nicks and dents (124) must be separated by at least the length of the longest nick or dent.

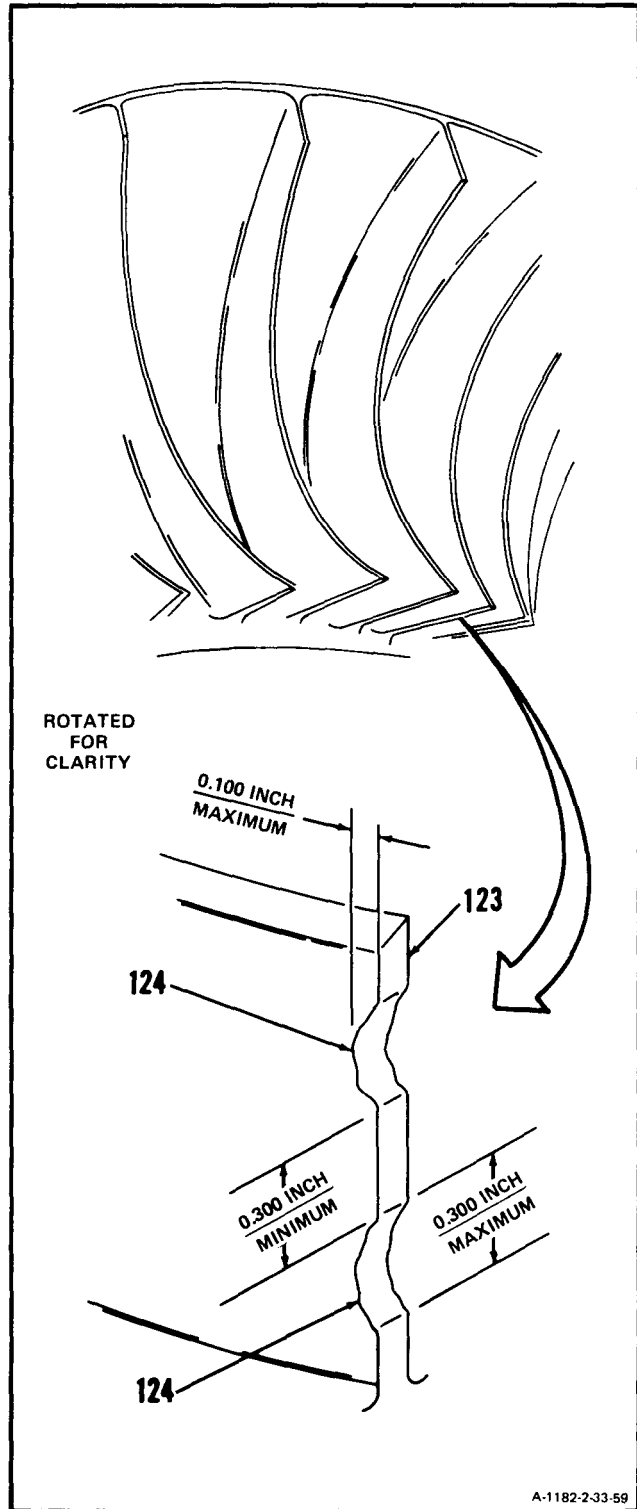

GO TO NEXT PAGE

- c. **Inspect trailing edge (125).** There shall be no cracks. There shall be no bends or distortion. There shall be no nicks or dents (126) deeper than 0.060 inch or longer than 0.300 inch. These nicks and dents (126) must be separated by at least the length of the longest nick or dent.

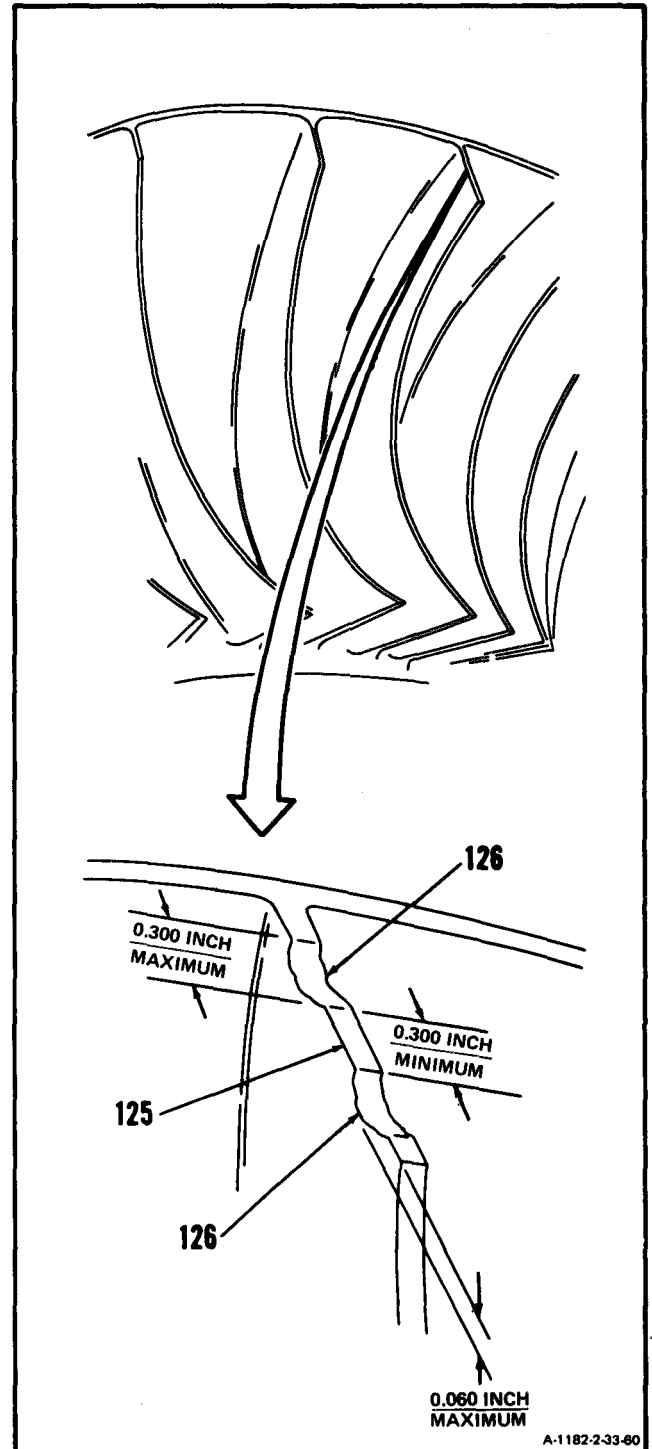

GO TO NEXT PAGE

- d. **Inspect blade tip (127).** There shall be no cracks. There shall be no bends or distortion. There shall be no more than six nicks or dents (128). These nicks and dents (128) shall not be deeper than 0.060 inch or longer than 0.300 inch and must be separated by 3/8-inch minimum.

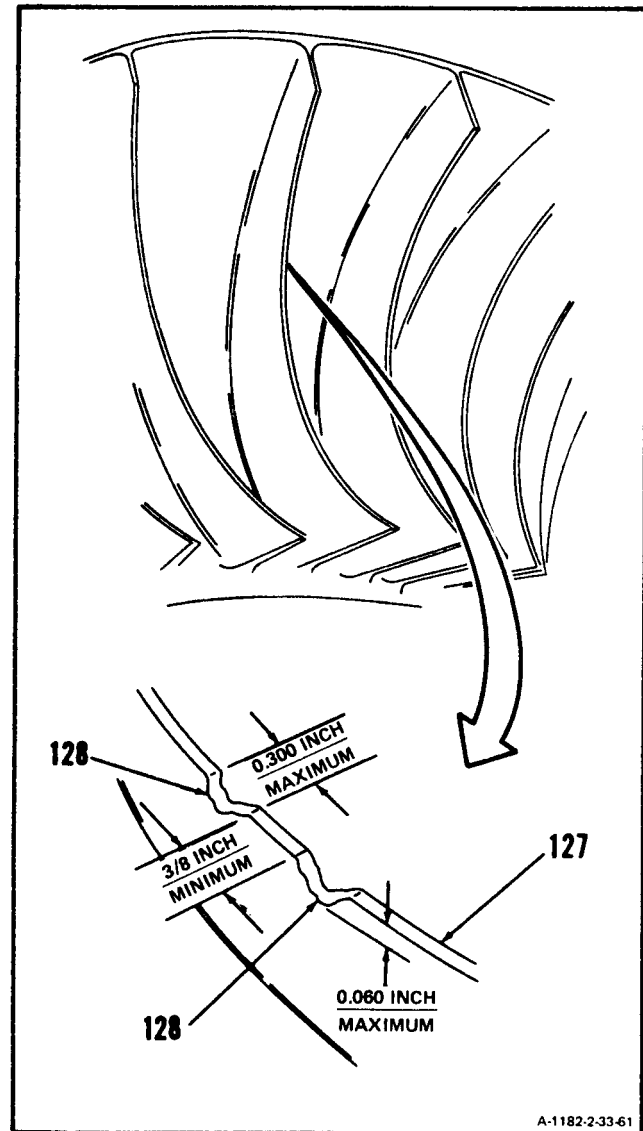

GO TO NEXT PAGE

- e. **Inspect airfoil surfaces (129).** There shall be no cracks. There shall be no bends or distortion. There shall be no nicks or dents (130) deeper than 0.030 inch or longer than 0.350 inch. These nicks and dents (130) must be separated by 1/2-inch minimum.

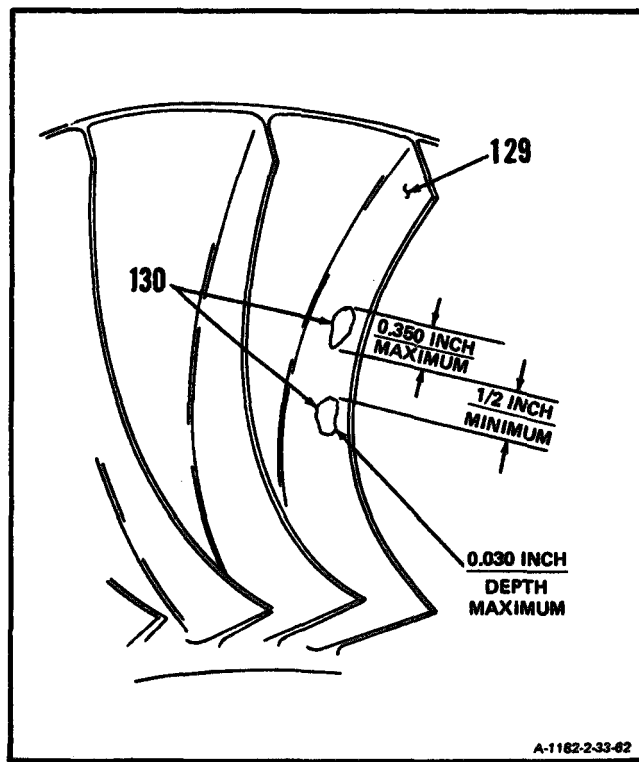

FOLLOW-ON MAINTENANCE:

None

END OF TASK

INITIAL SETUP

Applicable Configurations:

All

Tools:

Powerplant Mechanic's Tool Kit,
NSN 5180-00-323-4944
Technical Inspection Tool Kit,
NSN 5180-00-323-5114
Hand File Set
Micrometer Caliper Set

Materials:

Carborundum Stone (E10)
Crocus Cloth (E15)

Personnel Required:

68B10 Aircraft Powerplant Repairer
68B30 Aircraft Powerplant Inspector

References:

Task 2-31
Task 2-33
Task 2-35

NOTE

In following step, finish strokes shall be parallel to leading and trailing edges. When blade is repaired on leading or trailing edges, blend edges to a smooth radius.

1. **Blend-repair compressor rotor blades (1) that have allowable damage (Ref. Task 2-33).** Use files, Carborundum stone (E10) and crocus cloth (E15).
2. **Inspect repaired areas of blades (1).** Degree of repair shall not exceed maximum allowable inspection dimensions (Ref. Task 2-33) and the following:
 - a. On airfoil surfaces (2), three-quarters of blade thickness shall remain after repair.
 - b. Length of any repair shall be at least twice the depth of repair.
 - c. Length of any repair shall not be longer than five times the depth of repair.
 - d. There shall be no repair in critical area (3) of blade. Repairs begun out of critical area (3) shall not extend into critical area (3).

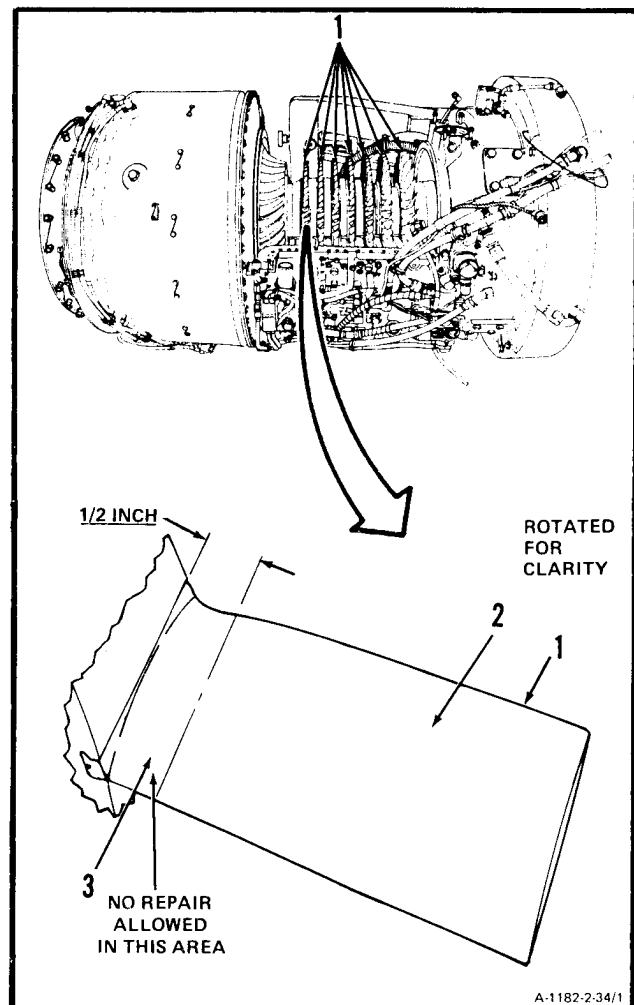
**GO TO NEXT PAGE**

- e. Repairs made within **0.120 inch** of blade tip corners (4) shall be blended to a smooth radius.

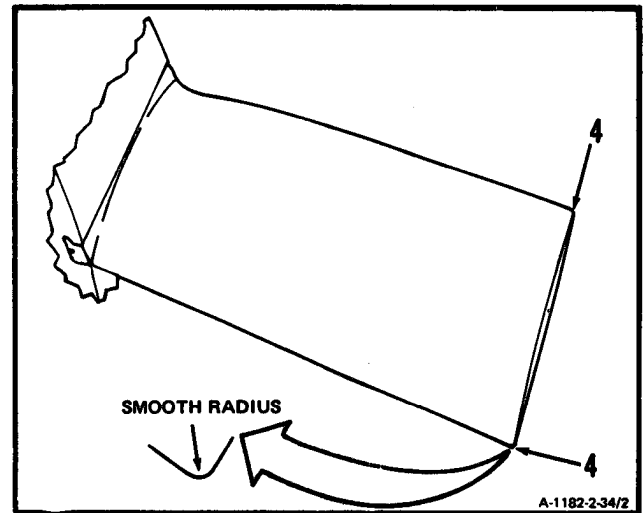

3. Replace blades (1) that have damage beyond limits or if repair limits cannot be met, as follows:

NOTE

There shall be no more than 50 blades replaced on compressor rotor between overhaul cycles.

- a. Replace blades (Ref. Task 2-31 and 2-35).
- b. Record number of blades replaced in engine log.

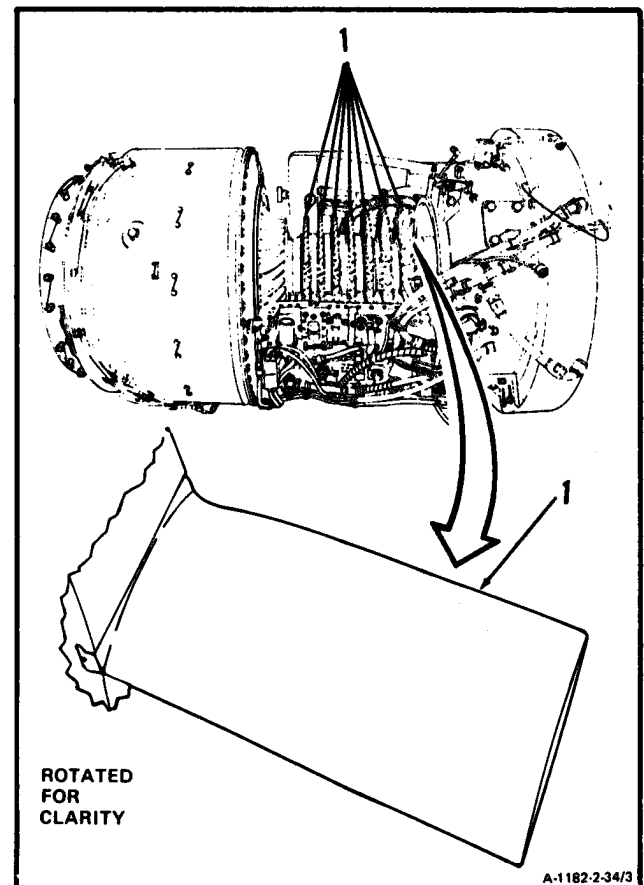

GO TO NEXT PAGE

NOTE

In following step, finish strokes shall be parallel to leading edge.

Blend-repair blades (1) to remove material roll-over(s) (5). Use files, Carborundum stone (E10) and crocus cloth (E15).

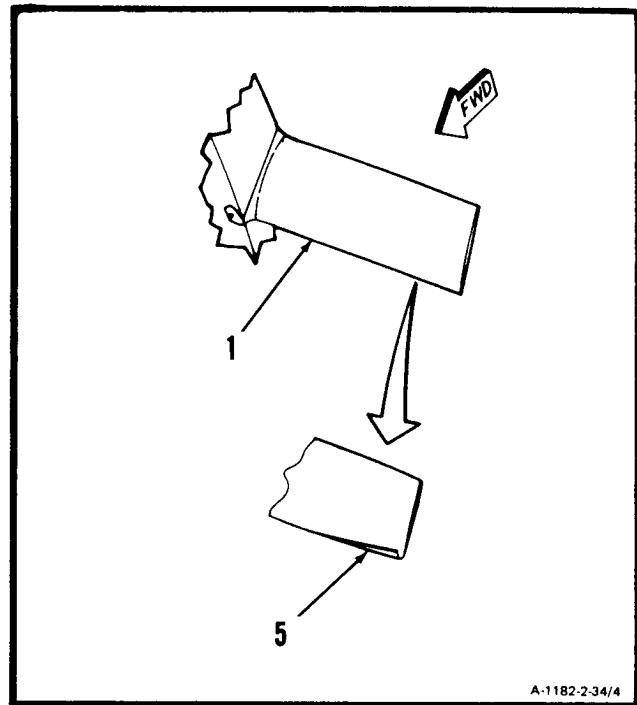
INSPECT

GO TO NEXT PAGE

2-34 REPAIR COMPRESSOR ROTOR BLADES (Continued)

2-34

5. Repair impeller assembly (6) as follows:

- a. There shall be no repair in critical area (7) of blade (8).

NOTE

The following repair is allowed only if size of defect after repair does not exceed inspection limits (Ref. Task 2-33).

- b. **Blend repair blades (8)** to a smooth contour in area of defect. Use Carborundum stone (E10). Make final strokes in radial direction.
- c. **Remove sharp edges** around repair. Use file. Make final strokes in radial direction.
- d. **Final polish repair area.** Use crocus cloth (E15). Make final strokes in radial direction.

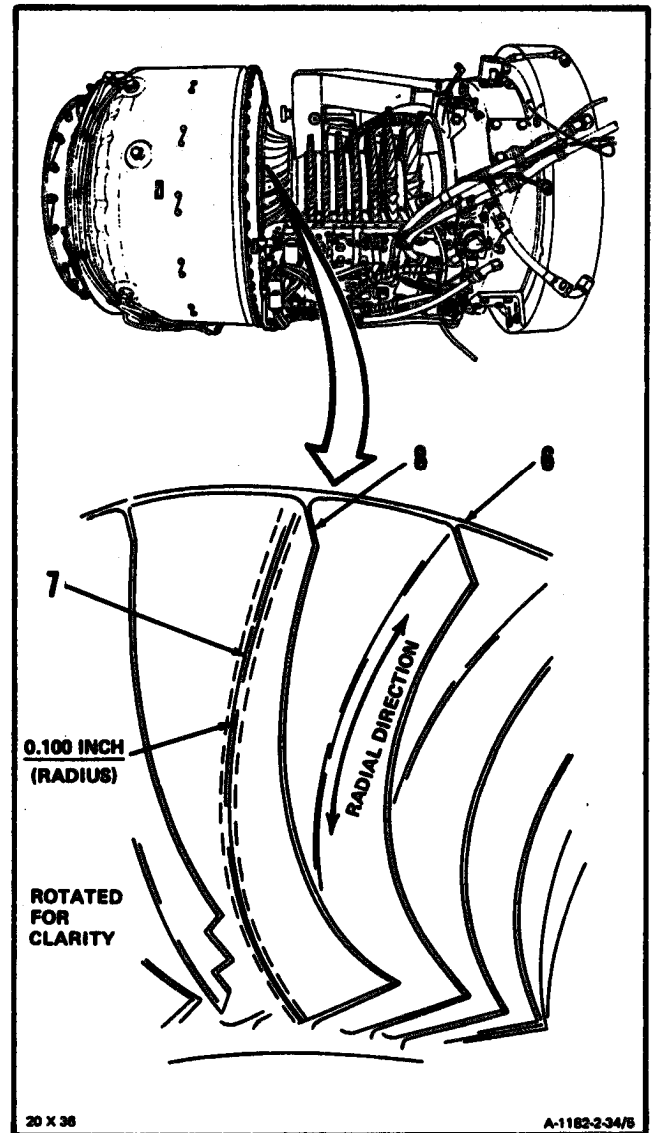
INSPECT**GO TO NEXT PAGE**

e. **Inspect repaired areas of blades (8)** as follows:

- (1) Use micrometer caliper. Measure blade wall thickness (9). Minimum blade wall thickness shall be 0.030 inch.
- (2) Inspect blade corners (10). Repaired areas within 0.120 inch of corners (10) shall be blended to a smooth radius. There shall be no sharp edges.
- (3) If damage to impeller assembly (6) exceeds limits after repair, replace engine.

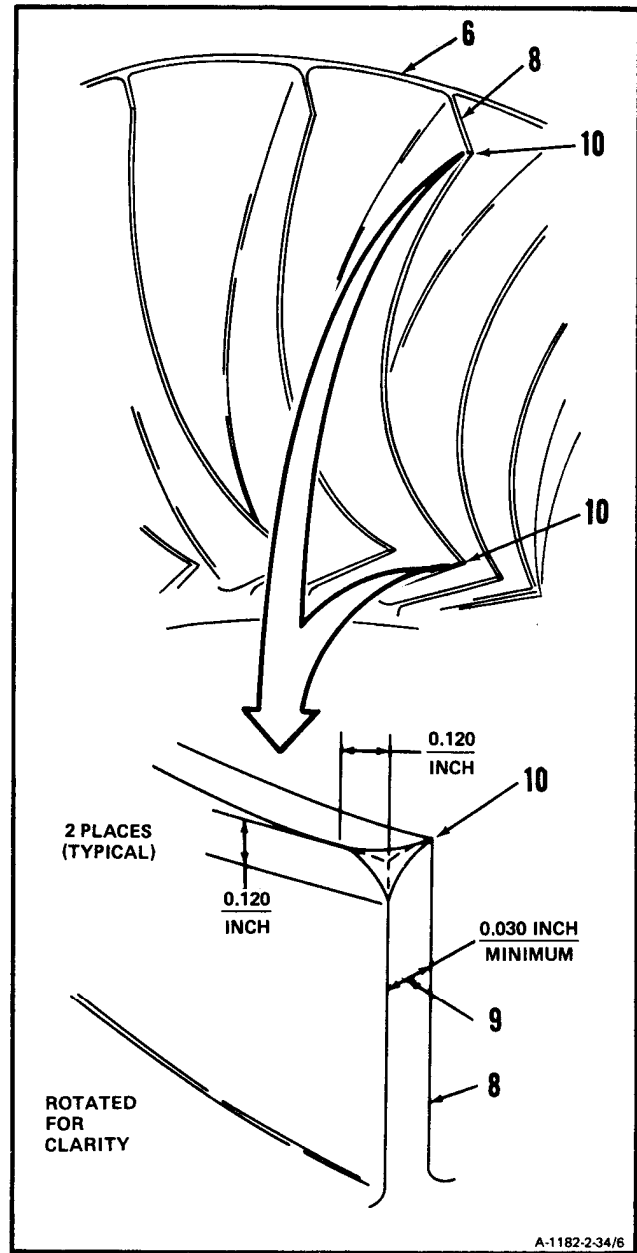

INSPECT

FOLLOW-ON MAINTENANCE:

None

END OF TASK

2-35 INSTALL COMPRESSOR ROTOR BLADES

2-35

INITIAL SETUP

Applicable Configurations:

All

Tools:

Powerplant Mechanic's Tool Kit,
NSN 5180-00-323-4944
Technical Inspection Tool Kit,
NSN 5180-00-323-5114
Drift Assembly (T19)
Installing Tool (T20)
Dial Indicator Support (T27)
Installation Tool Kit (T31)
Hand File Set
Balance Scale,
NSN 6670-00-401 -7195
Dial Indicator
Rawhide Mallet

Tweezers,
NSN 5120-00-247-0868
Surface Plate

Materials:

Abrasive Paper (E3)
Lockwire (E28)

Parts:

Springs
Pins
Key Washers

Personnel Required:

68B10 Aircraft Powerplant Repairer (2)
68B30 Aircraft Powerplant Inspector

References:

TM 55-2840-254-23P

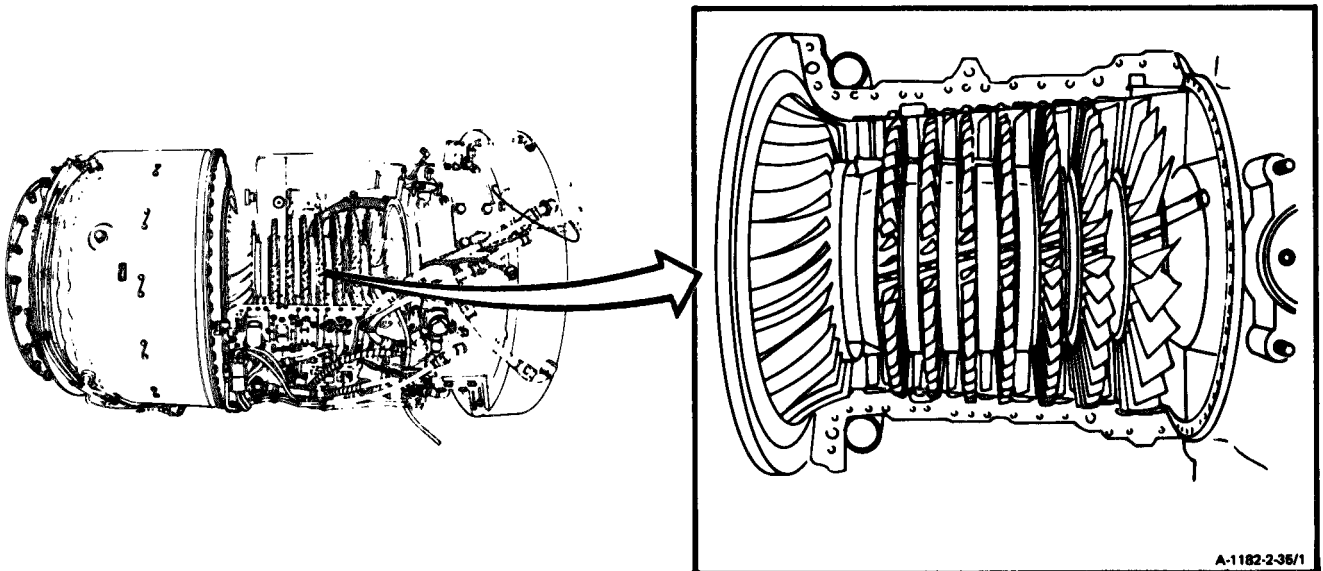

GO TO NEXT PAGE

1. Install first stage blade (1) into disc as follows:

- a. **Weigh serviceable blade and damaged blade** that is to be replaced using balance scale.

NOTE

Weight of blades shall be within 0.1 gram of each other.

NOTE

Damaged blade may have excessive missing material. If this occurs, remove opposite blade 180 degrees away. Weigh and select serviceable blade having same weight within 0.1 gram difference. If correct blade weight is not available, select two serviceable blades of equal weight. Install blades 180 degrees apart.

NOTE

If more than 10 single blades are replaced, each additional serviceable blade must exactly match weight of blade removed. It may not be possible to match weights of old and serviceable blades. If this happens, additional blades must be replaced in matched sets.

NOTE

Number of blades and stages in which they were replaced must be entered in engine record. Maximum of 50 blades may be replaced on compressor rotor between overhaul cycles.

- b. **Select serviceable blade (1) that is within 0.1 gram in weight of blade to be replaced.** Refer step a. above for weighing procedure.

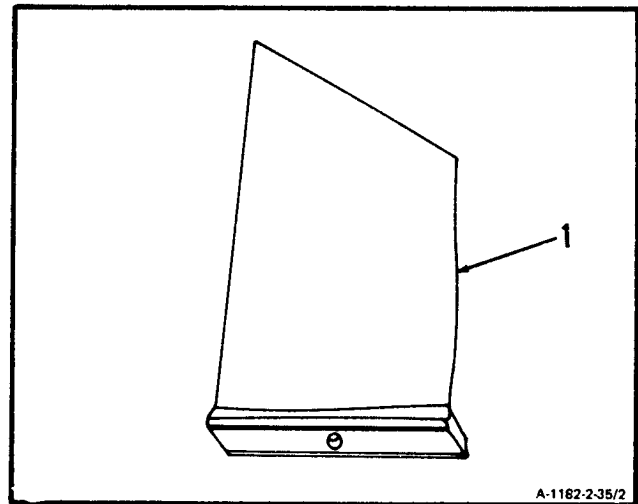
**INSPECT****GO TO NEXT PAGE**

2-35 INSTALL COMPRESSOR ROTOR BLADES (Continued)**2-35**

- c. Remove metal evenly from bottom of base of serviceable blade (1) with abrasive paper (E3) (2) and flat surface plate (3). Remove just enough metal to obtain slight press fit in disc.

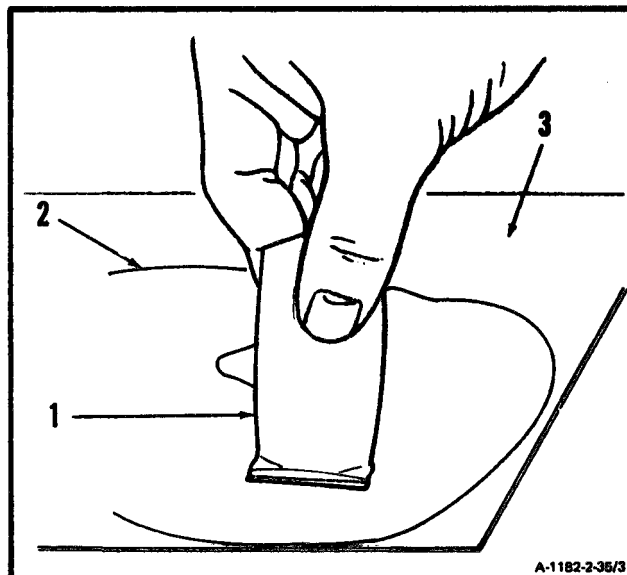

- d. Align empty blade dot in disc (4) with dot (5) in bearing housing.

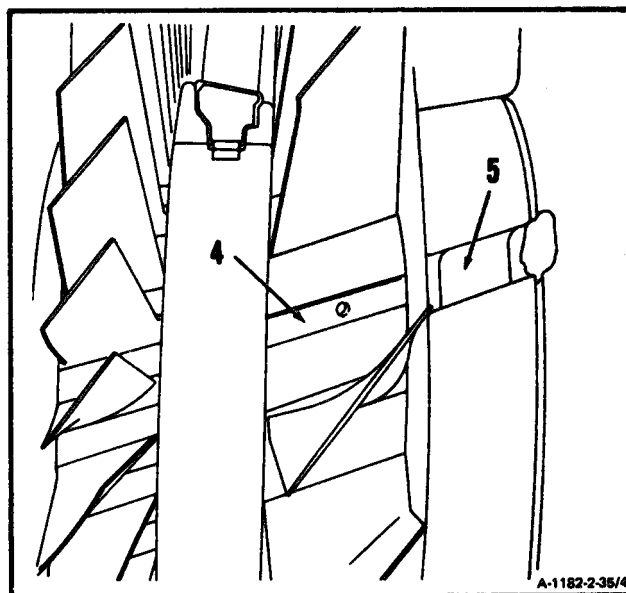
**GO TO NEXT PAGE**

e. Install blade (1) rearward by hand temporarily into disc slot (4).

NOTE

It is not necessary to install lockpin or spring at this time.

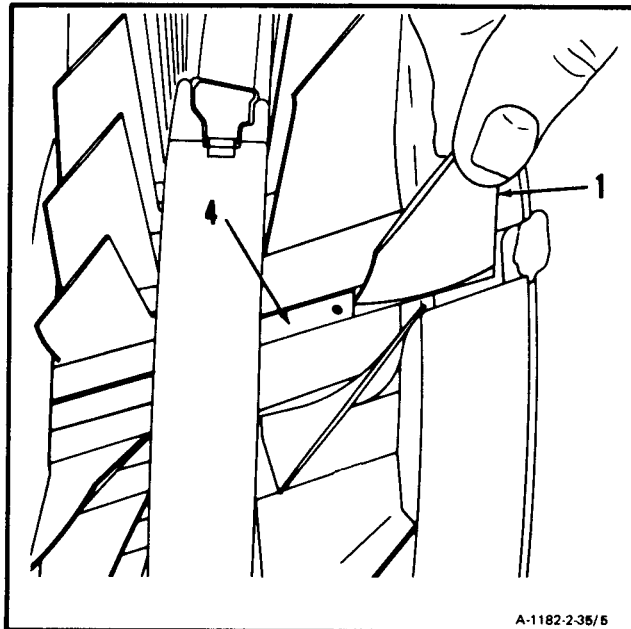

A-1182-2-35/5

f. Install dial indicator as follows:

(1) Remove three bolts (6) and key washers (7).

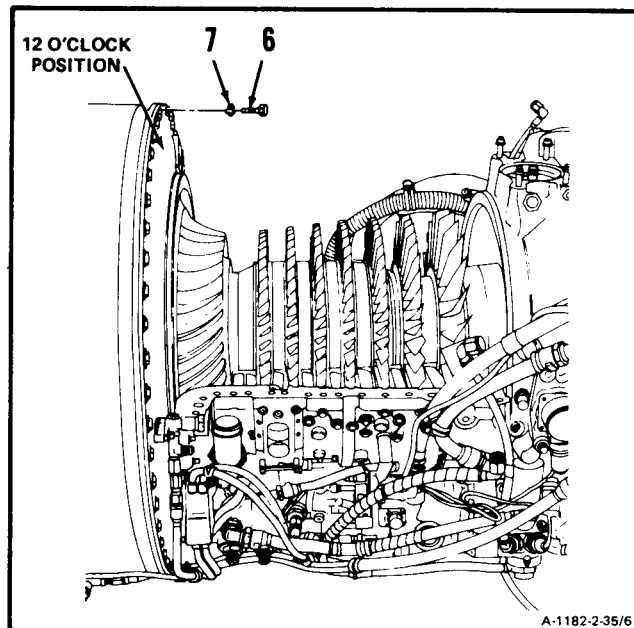

A-1182-2-35/6

GO TO NEXT PAGE

2-35 INSTALL COMPRESSOR ROTOR BLADES (Continued)

2-35

- (2) Install dial indicator support (T27) (8) and three bolts (9) on housing (10).

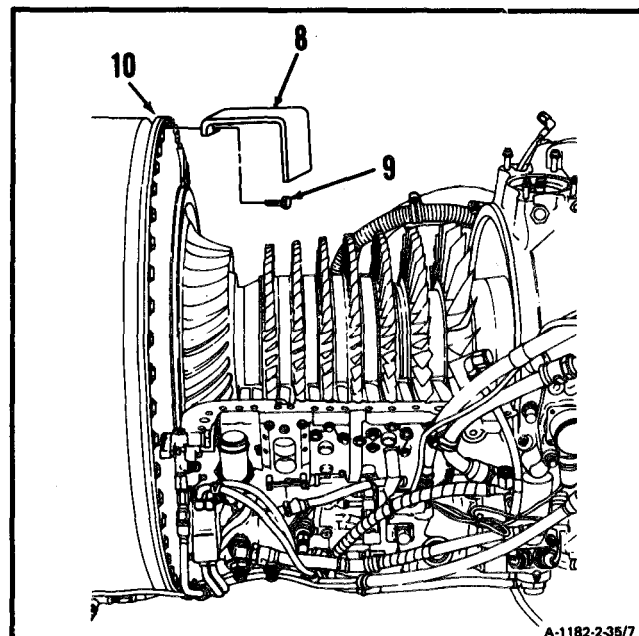

- (3) Install dial indicator magnetic base (11) and dial indicator (12) on dial indicator support (8).

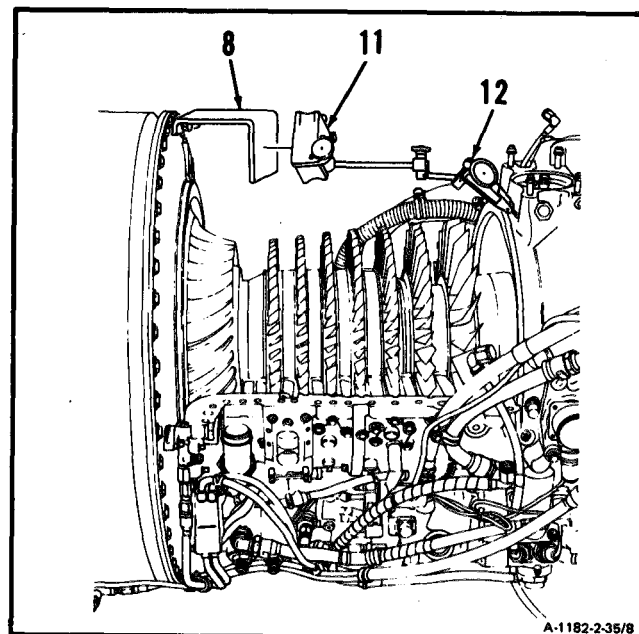
**GO TO NEXT PAGE**

NOTE

Tip shake limits shall be taken only if blade was replaced.

- g. **Check tip shake limits** with dial indicator (12). Measure radial movement of blade by a radial measurement of 2.0 inches from outer rim of disc. **Tip shake limits shall be 0.005 to 0.059 inch.** If minimum tip shake cannot be met, repeat steps c. through e. If tip shake exceeds maximum limits, replace blade.

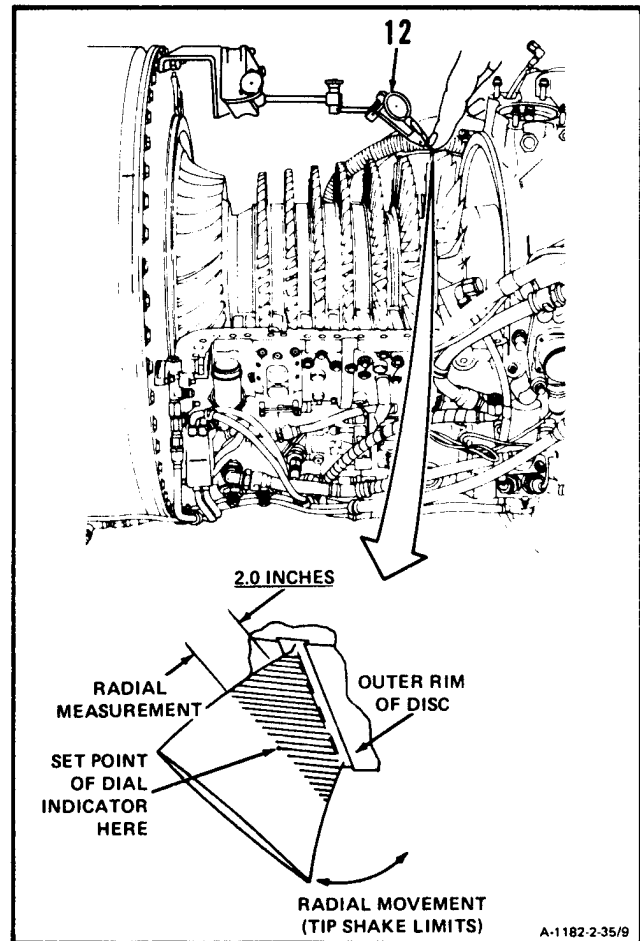

INSPECT

- h. **Remove dial indicator** from dial indicator support.

GO TO NEXT PAGE

2-35 INSTALL COMPRESSOR ROTOR BLADES (Continued)

- i. Measure tip clearance of serviceable blade(1) using thickness gage (13).

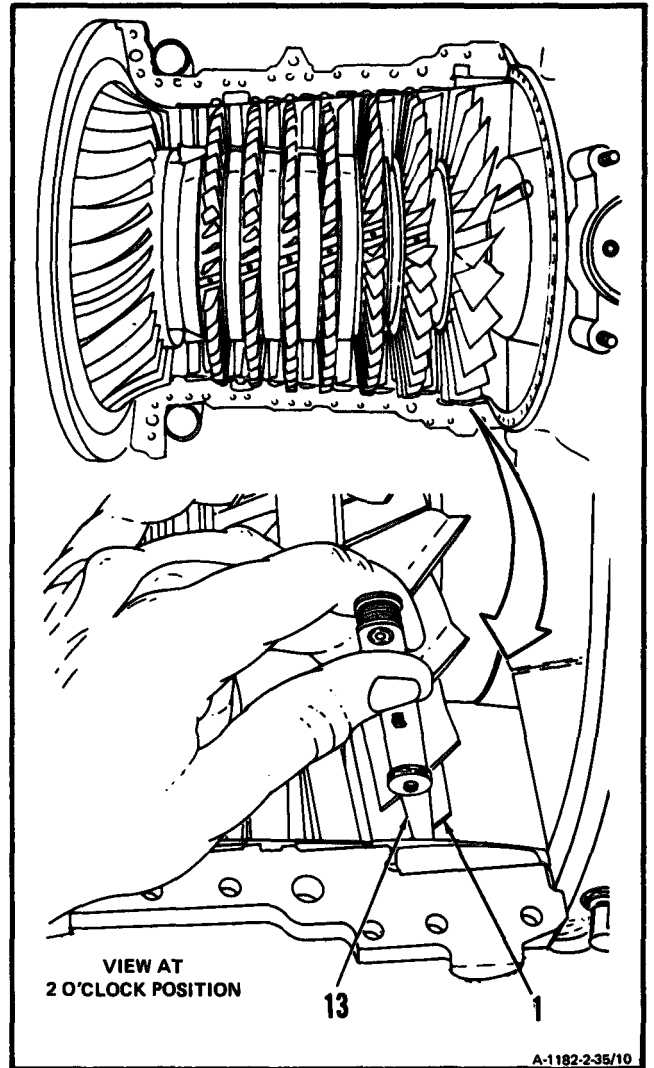

GO TO NEXT PAGE

CAUTION

Do not use power grinder to remove metal from blade. Power grinder could easily damage blade.

NOTE

Measure the tip clearance of the adjoining blades to ensure serviceability (.019 - .029 inch) prior to filing.

- j. File tip of blade (14) with file (15) to obtain tip clearance equal to two adjacent blades.

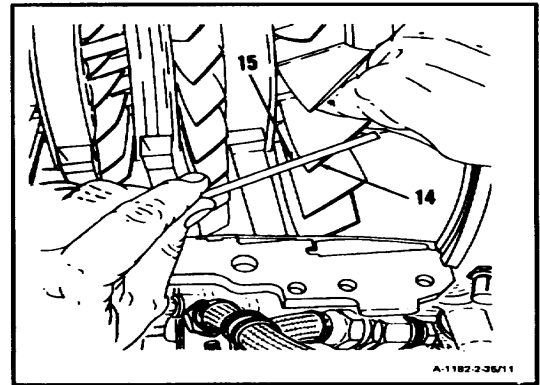

INSPECT

- k. Realign blade (1) with slot (5) in bearing housing.

GO TO NEXT PAGE

2-324 Change 6

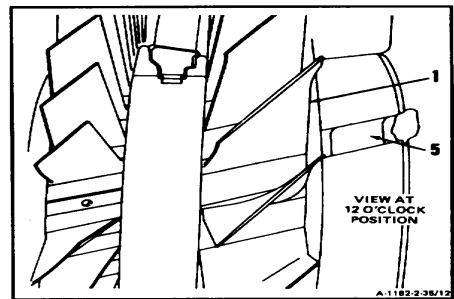

2-35 INSTALL COMPRESSOR ROTOR BLADES (Continued)

2-35

1. Remove blade (1) by hand. Sliding blade forward.

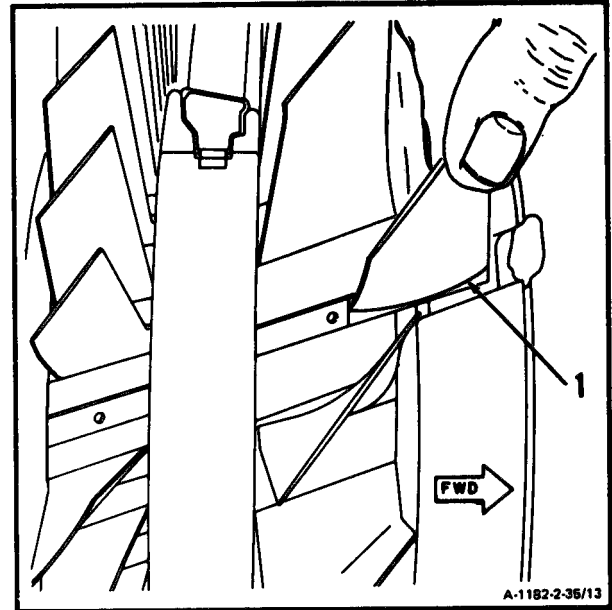

GO TO NEXT PAGE

m. **Insert** length of **lockwire (E28) (16)** into slot in base of blade (1) as far as it will go.

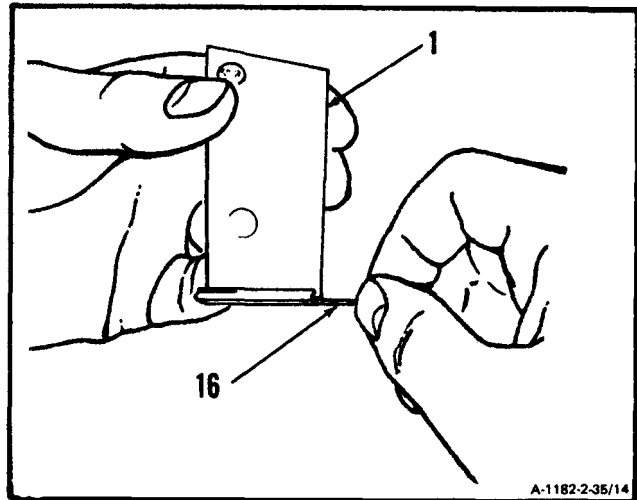

n. **Bend** lockwire (16) to indicate depth of slot. **Remove** lockwire (16) and retain for use in following step t.

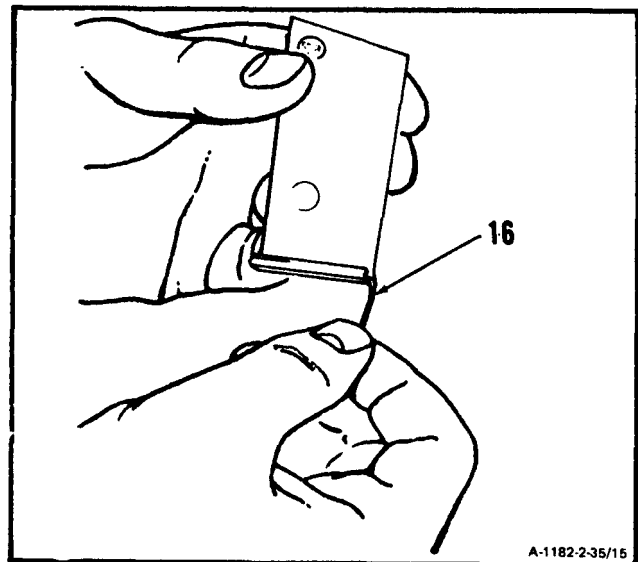

GO TO NEXT PAGE

2-35 INSTALL COMPRESSOR ROTOR BLADES (Continued)

2-35

- o. Reinsert blade (1) rearward partway into disc slot (4).

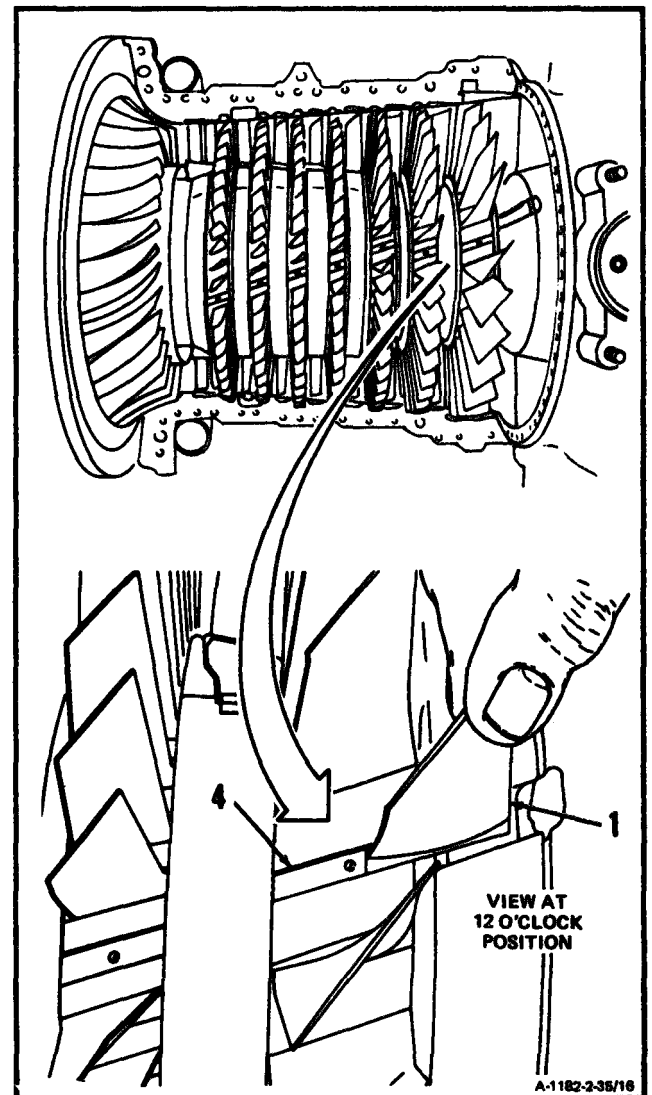

GO TO NEXT PAGE

2-35 INSTALL COMPRESSOR ROTOR BLADES (Continued)**2-35**

- p. **Install new spring (17)** into hole in disc slot (4) using tweezers (18).

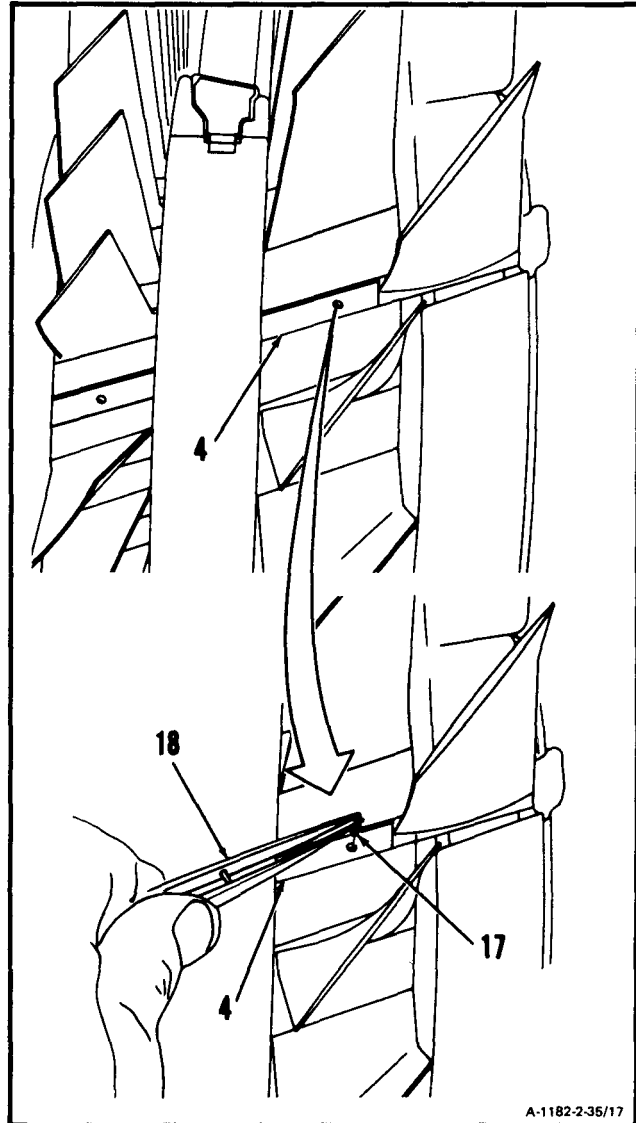
**GO TO NEXT PAGE**

- q. **Install new lockpin (19)** into hole in disc slot (4) using tweezers (18) and scribe (20).

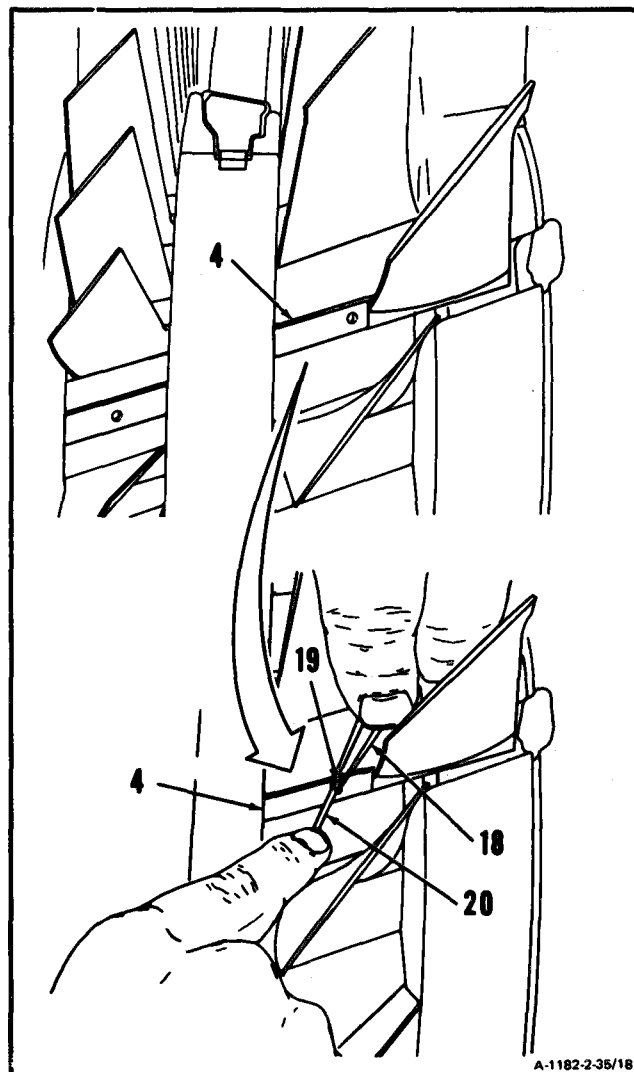

GO TO NEXT PAGE

- r. **Depress lockpin (19) with scribe (20)** and install blade (1) rearward. As soon as blade (1) edge catches lockpin pull scribe (20) away.

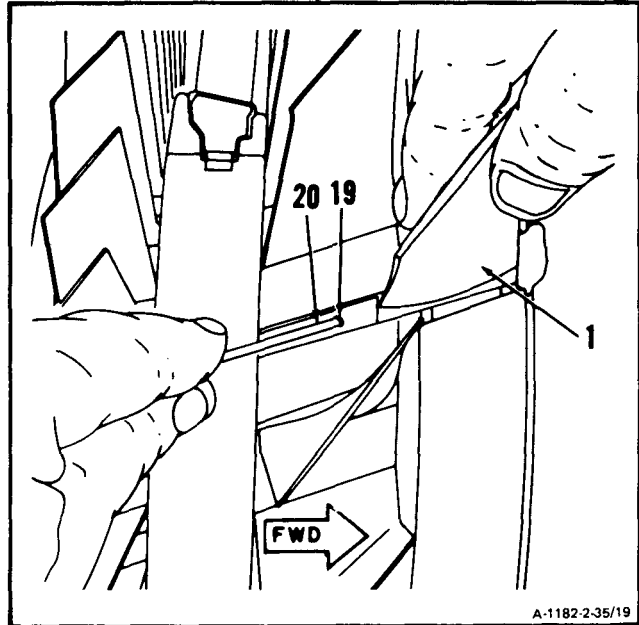

- s. **Engage lockpin** by installing blade (1) completely into disc slot by hand.

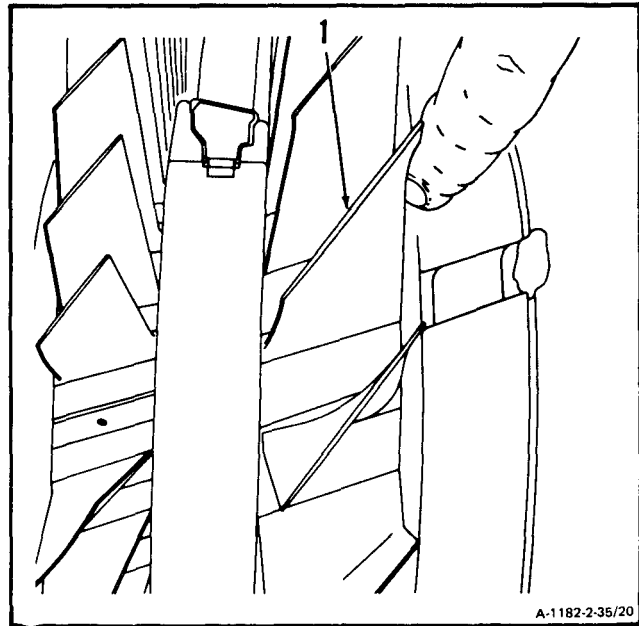

GO TO NEXT PAGE

2-35 INSTALL COMPRESSOR ROTOR BLADES (Continued)

2-35

- t. Check engagement of lock-pin by reinserting bent piece of lock-wire (16) used in previous step n. Insert lock-wire (16) into slot in base of blade (1).

NOTE

Bend of wire shall protrude 1/16 inch from end of blade when wire is bottomed on lock-pin.

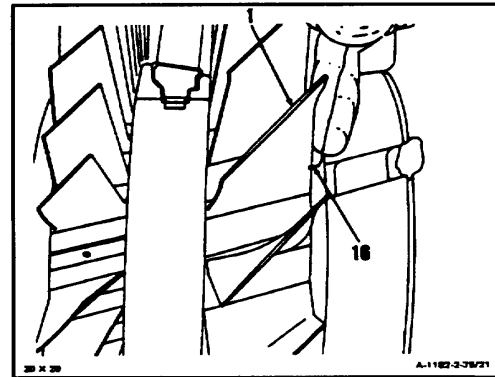

INSPECT

- u. Inspect for (1) protrusion from disc. Protrusion at forward face (22) shall not exceed 0.015 inch. Protrusion at rear face (21) shall not exceed 0.010 inch.

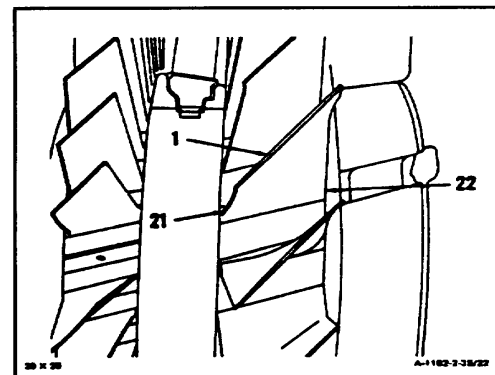

INSPECT

GO TO NEXT PAGE

- v. Check clearance between compressor housing and compressor rotor blades. Using thickness gage (13) check right and left sides of compressor housing. Tip clearance shall be 0.019 inch minimum.

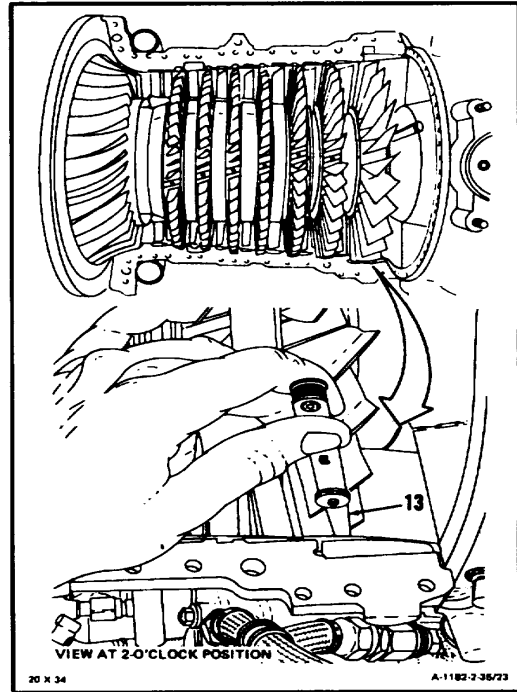

INSPECT

GO TO NEXT PAGE

2-332 Change 6

2. Install second through seventh stage compressor blades as follows:

- a. **Weigh serviceable blade and damaged blade** that is to be replaced using balance scale.

NOTE

Weight of blades shall be within 0.1 gram of each other.

NOTE

Damaged blade may have excessive missing material. If this occurs, remove opposite blade 180 degrees away. Weigh and select serviceable blade having same weight within 0.1 gram difference. If correct blade weight is not available, select two serviceable blades of equal weight. Install blades 180 degrees apart.

NOTE

If more than 10 single blades are replaced, each additional serviceable blade must exactly match weight of blade removed. It may not be possible to match weights of old and serviceable blades. If this happens, additional blades must be replaced in matched sets.

NOTE

Number of blades and stages in which they were replaced must be entered in engine record. Maximum of 50 blades may be replaced on compressor rotor between overhaul cycles.

NOTE

This procedure shows third stage compressor blades. It is also applicable to second, fourth, fifth, sixth and seventh stage compressor blades.

GO TO NEXT PAGE

- b. **Select serviceable blade (23) that is within 0.1 gram in weight of blade to be replaced.**
Refer to step 2.a. for weighing procedure.

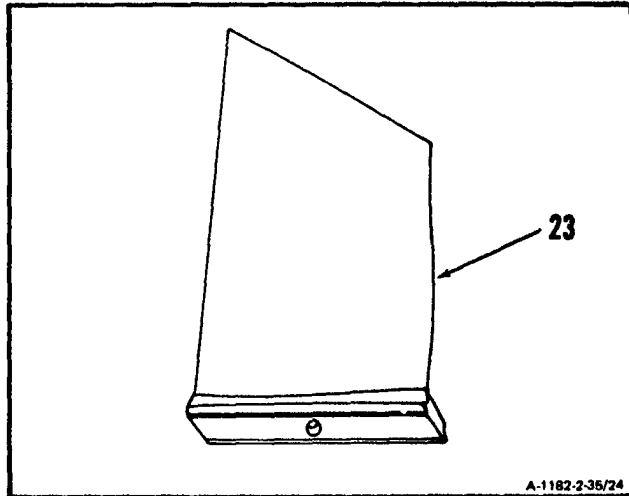

INSPECT

- c. **Remove metal evenly from bottom of base of serviceable blade (23) with abrasive paper (E3) (2) and flat surface plate (3). Remove just enough metal to obtain slight press fit in disc.**

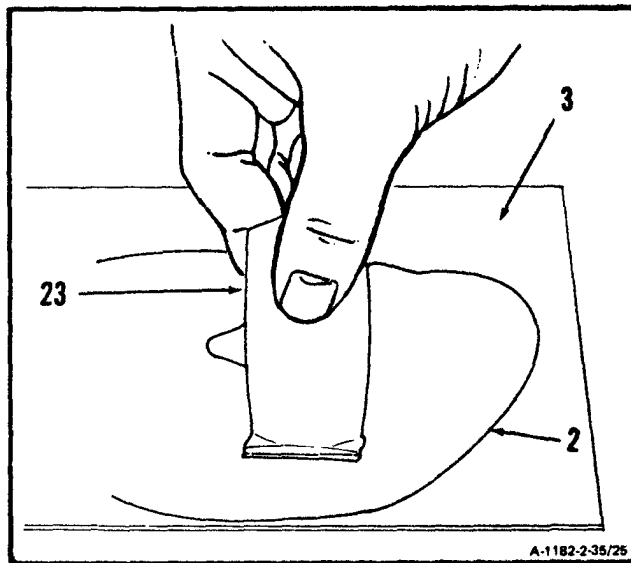

GO TO NEXT PAGE

2-35 INSTALL COMPRESSOR ROTOR BLADES (Continued)

2-35

- d. Install blade (23) rearward temporarily into compressor disc slot using rawhide mallet and installation tool and rod contained in kit (T31) (24).

NOTE

It is not necessary to install lockpin or spring at this time.

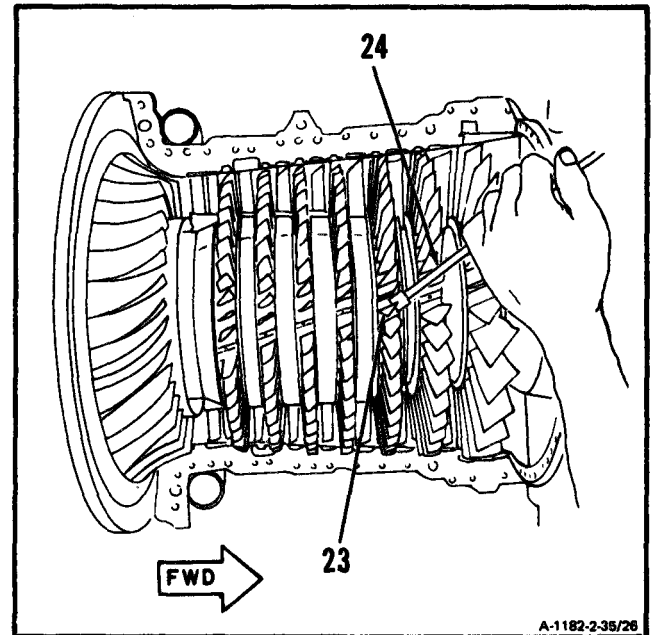

- e. Install dial indicator magnetic base (11) on dial indicator support (8).

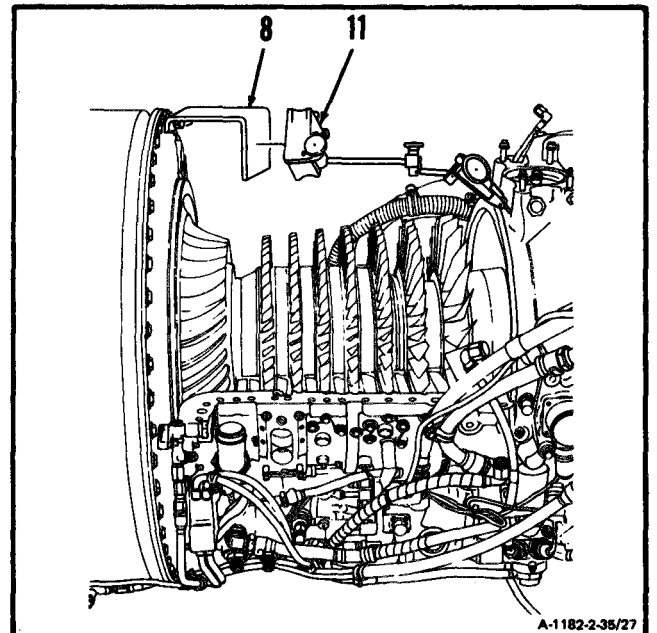

GO TO NEXT PAGE

- f. **Check tip shake limits** for second through seventh stage blades with dial indicator (12). **Measure radial movement of blade using a radial measurement from outer rim of disc.** Tip shake limits are as follows:

NOTE

Tip shake limits shall be taken only on replaced blade.

- (1) **Second Stage.** Measure radial movement of blade using a radial measurement of 1.75 inches from outer rim of disc. Tip shake limits shall be 0.005 to 0.051 inch.
- (2) **Third Stage.** Measure radial movement of blade using a radial measurement of 1.5 inches from outer rim of disc. Tip shake limits shall be 0.005 to 0.045 inch.
- (3) **Fourth through seventh stage.** Measure radial movement of blade using a radial measurement of 1.375 inches from outer rim of disc. Tip shake limits shall be 0.005 to 0.040 inch.

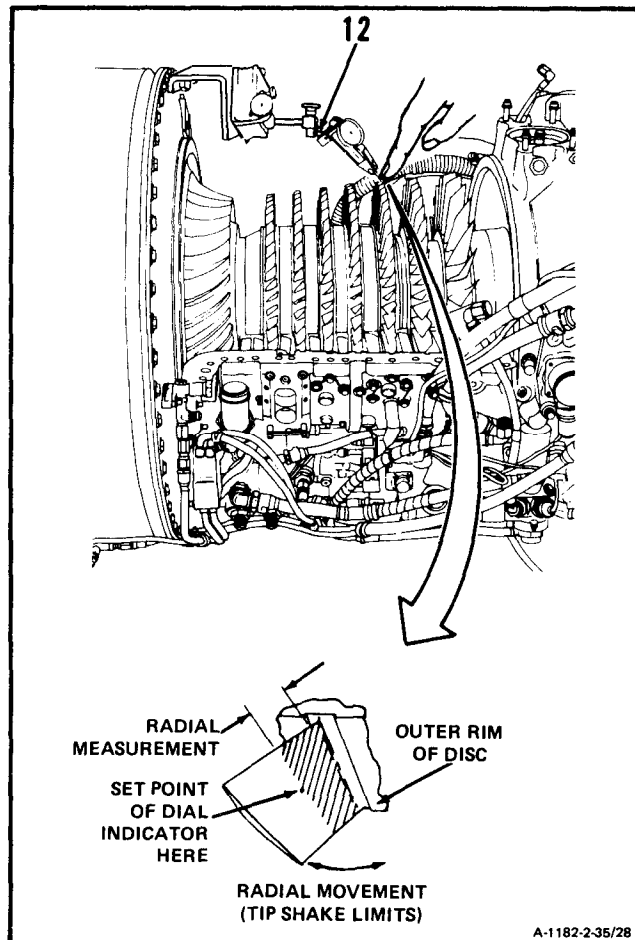

INSPECT

GO TO NEXT PAGE

2-35 INSTALL COMPRESSOR ROTOR BLADES (Continued)**2-35**

g. **Remove dial indicator** as follows:

- (1) Remove magnetic base (11) of dial indicator from dial indicator support (8).

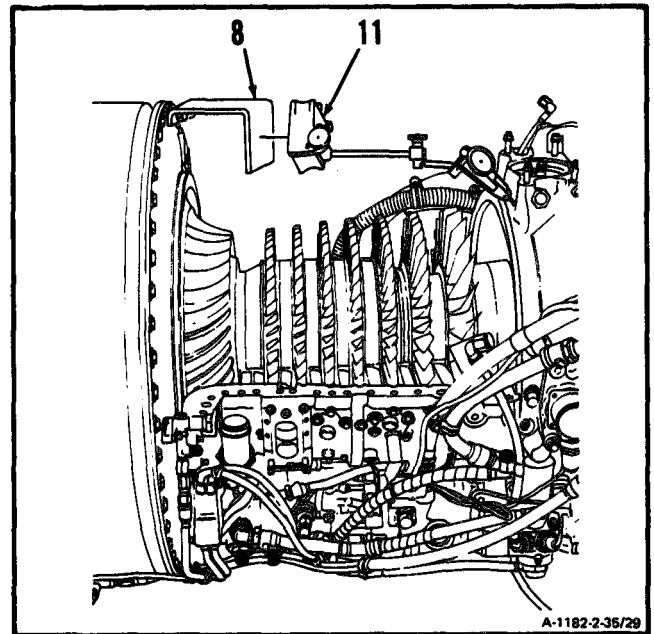

- (2) Remove three bolts (9) and dial indicator support (T27) (8) from housing (10).

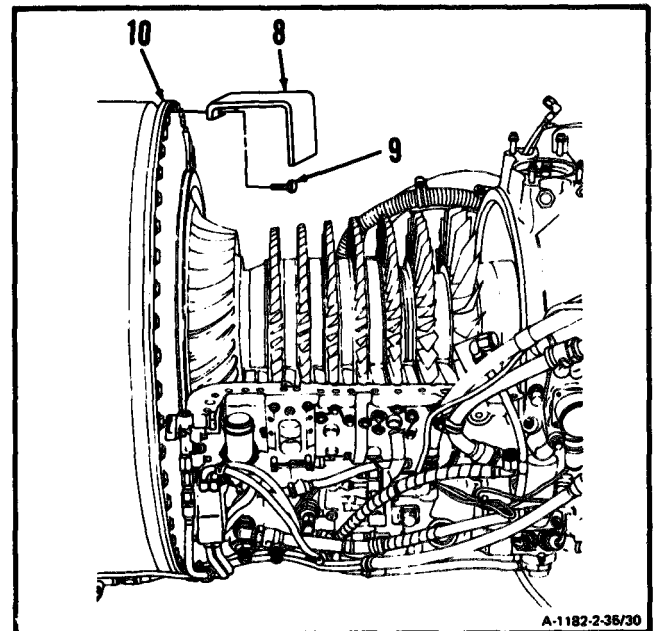

GO TO NEXT PAGE

2-35 INSTALL COMPRESSOR ROTOR BLADES (Continued)

2-35

- (3) Install three bolts (6) and key washers (7).
- (4) Lock bolts (6) by bending tabs of key washers (7).

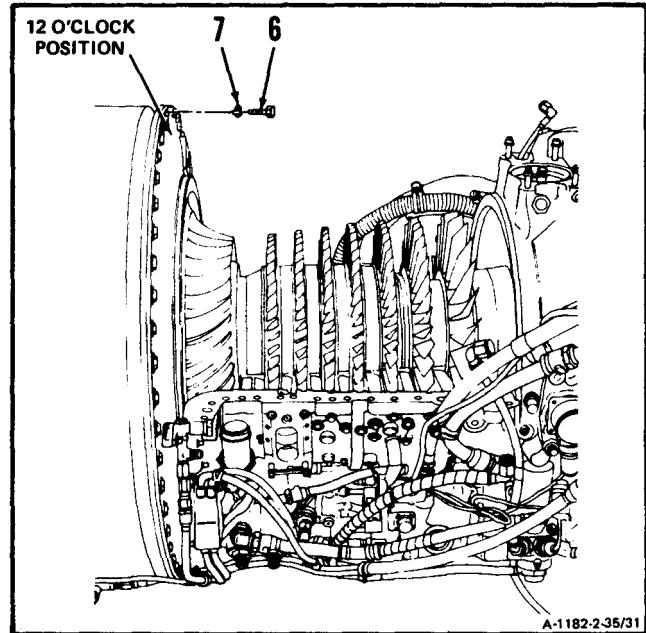
**GO TO NEXT PAGE**

- h. **Measure tip clearance** of serviceable blade (23) using thickness gage (13).

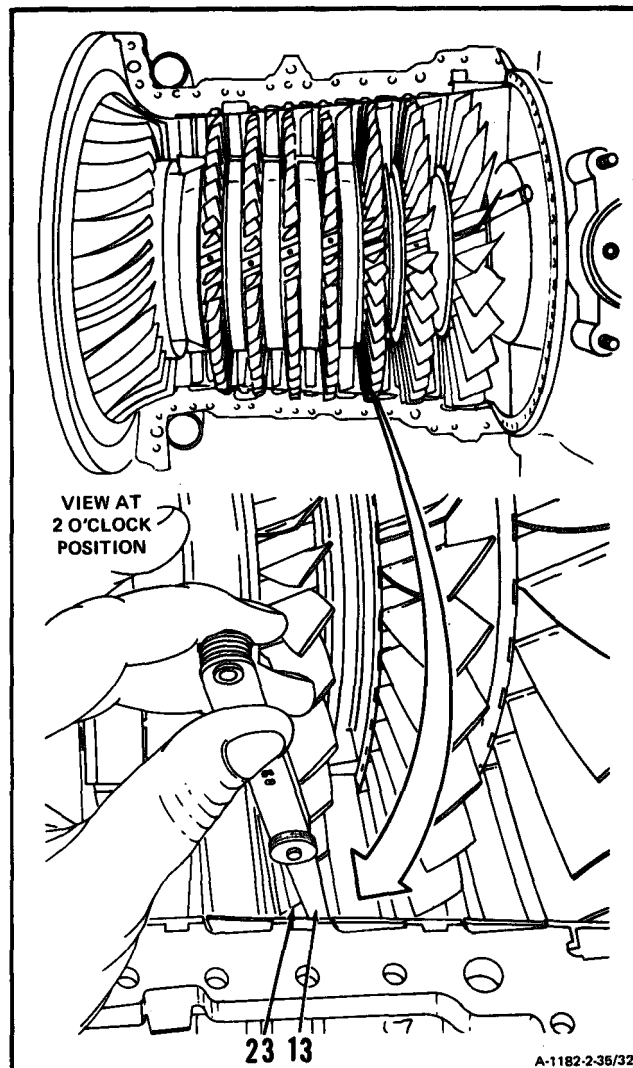

GO TO NEXT PAGE

CAUTION

Do not use power grinder to remove metal from blade. Power grinder could easily damage blade.

- i. **File tip of blade (23)** with file (15) to obtain tip clearance equal to two adjacent blades.

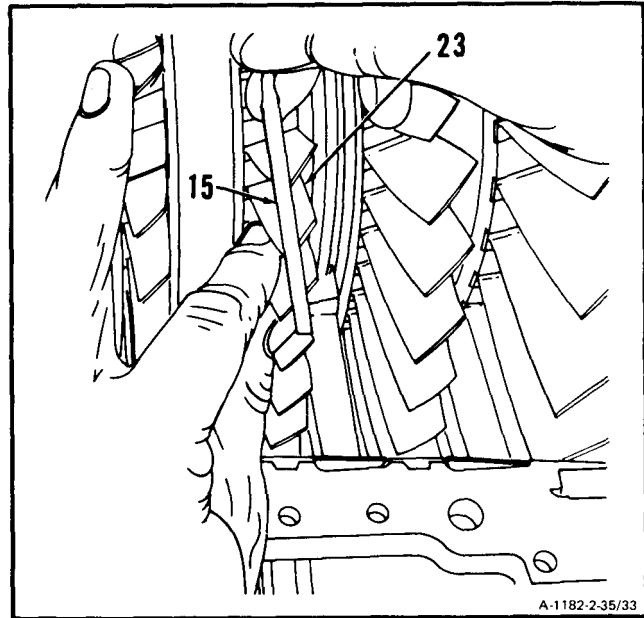

INSPECT

NOTE

In following step, use drift assembly (T19) for second stage blades. Use installing tool (T20) for third through seventh stage blades.

NOTE

In following step, second and third stage blades are removed forward, fourth through seventh stage blades are removed rearward. Third stage blade removal is shown.

- j. **Remove blade (23)** using rawhide mallet and installing tool (T20) (25) **by tapping blade (23) forward.**

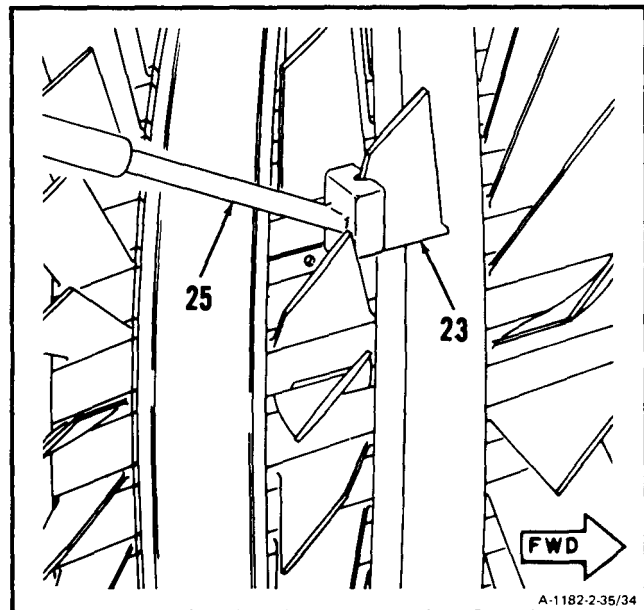

GO TO NEXT PAGE

CAUTION

A new piece of lockwire must be used for each stage.

- k. **Insert** length of **lockwire (E28) (16)** into slot in base of blade (23) as far as it will go.

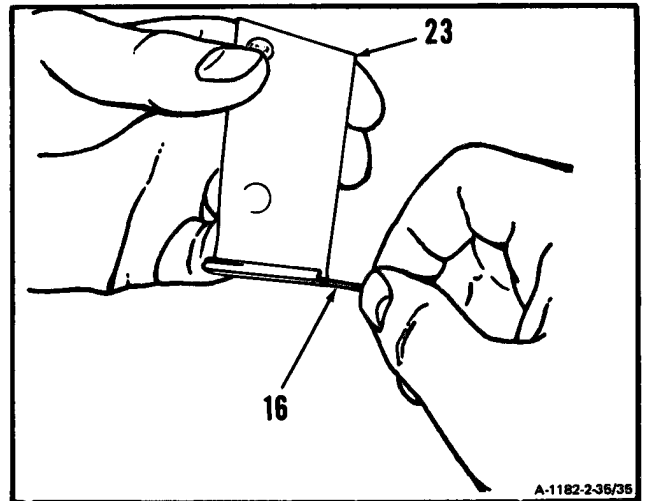

- l. **Bend** lockwire (16) to indicate depth of slot. **Remove** lockwire (16) and **retain** for use in following step r.

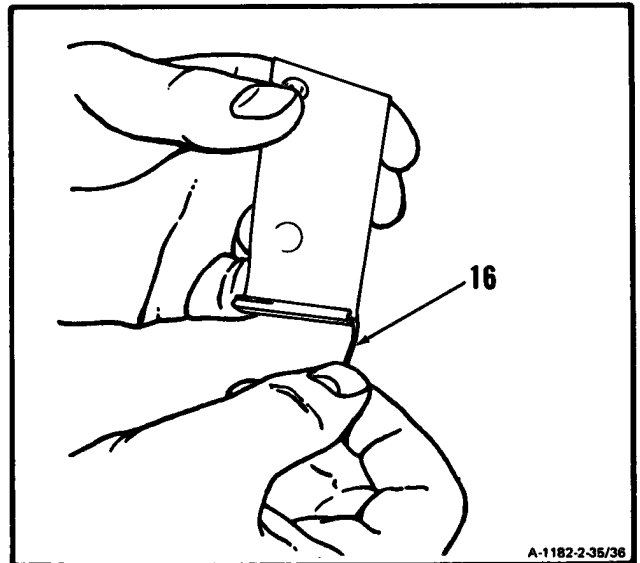

GO TO NEXT PAGE

- m. Reinsert blade (23) rearward part way into disc slot. Use rawhide mallet and installation tool and rod contained in kit (T31) (24).

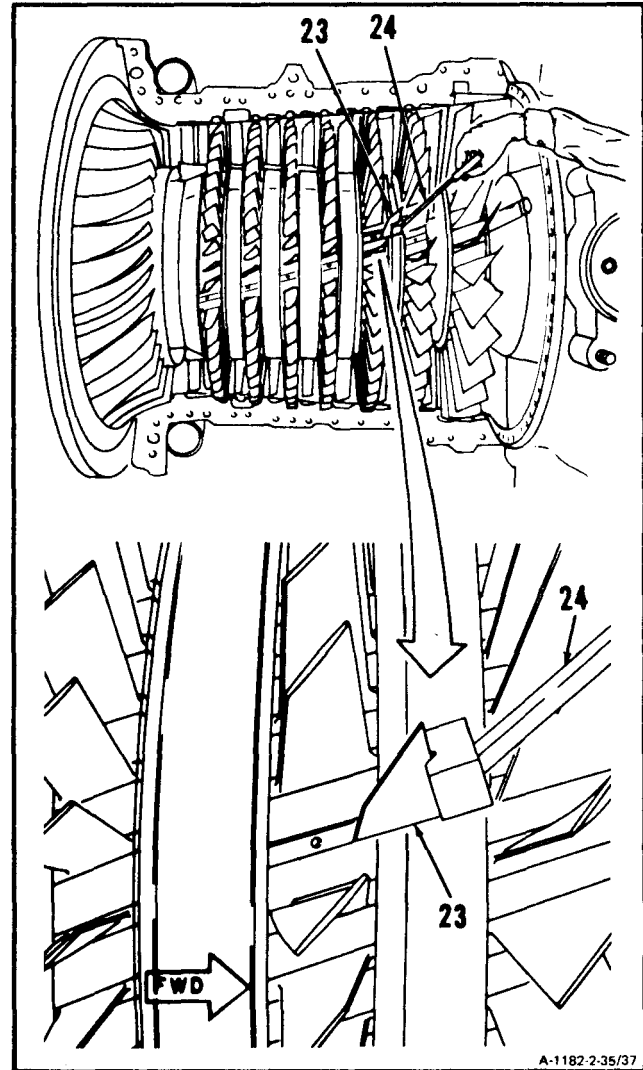

GO TO NEXT PAGE

2-35 INSTALL COMPRESSOR ROTOR BLADES (Continued)

2-35

- n. **Install new spring (26)** into hole in disc slot using tweezers (18).

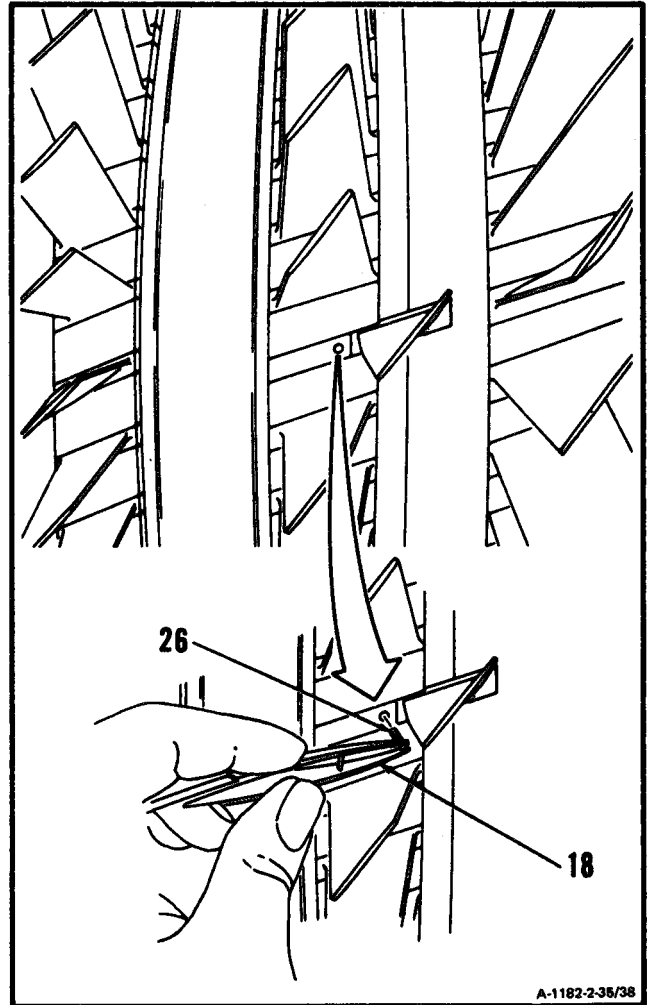

GO TO NEXT PAGE

- o. Install new lockpin (27) into hole in disc slot using tweezers (18).**

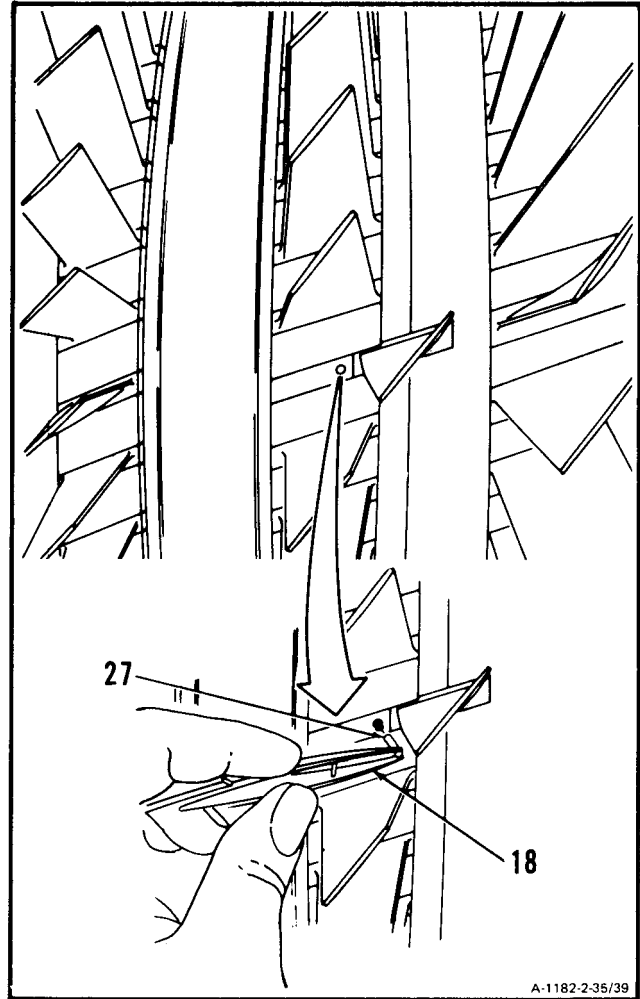

GO TO NEXT PAGE

NOTE

Two people are required for this step.

- p. **Depress lockpin with scribe (20). Have helper tap blade (23) rearward into disc slot using rawhide mallet and installation tool and rod contained in kit (T31) (24). As soon as blade (23) catches lockpin, pull scribe (20) away.**

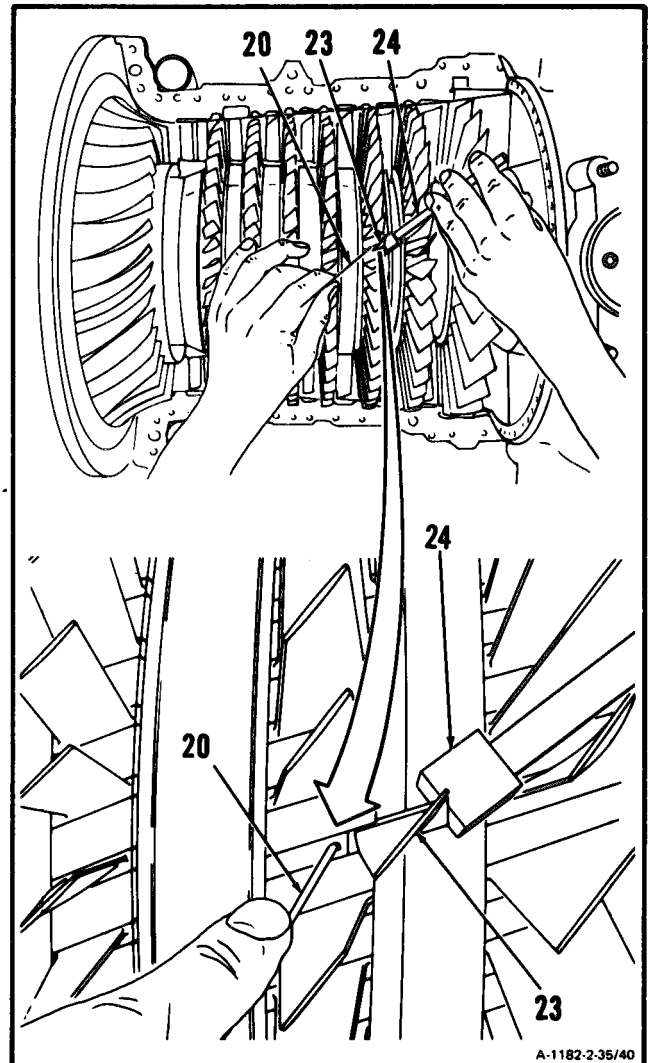

GO TO NEXT PAGE

- q. **Engage lockpin** by installing blade (23) rearward completely into disc slot. Use rawhide mallet and installation tool and rod contained in kit (T31) (24).

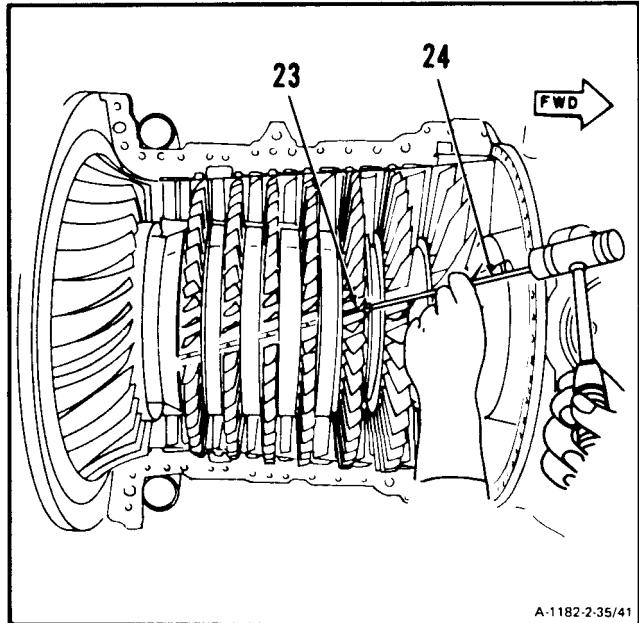

- r. **Check engagement of lockpin** by reinserting bent piece of lockwire (16) used in previous step 1. **Insert lockwire (16)** into slot in base of blade (23) with tweezers (18). Bend of wire shall protrude 1/16 inch from end of blade (23) when wire is bottomed on lockpin.

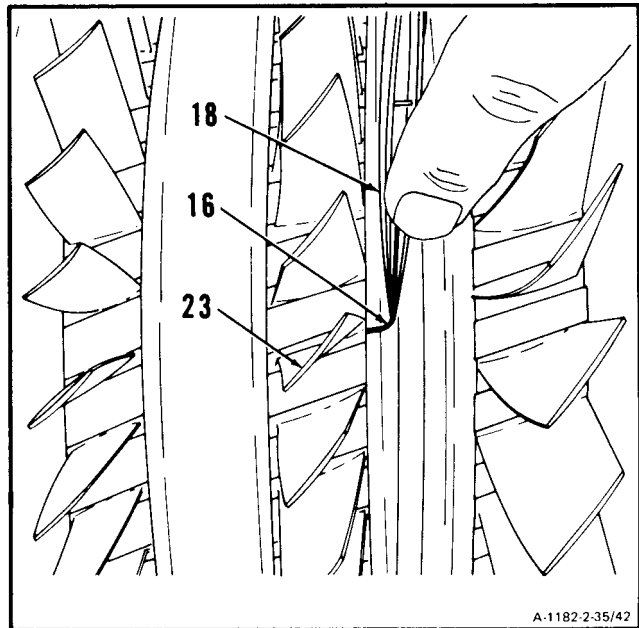

INSPECT

GO TO NEXT PAGE

2-35 INSTALL COMPRESSOR ROTOR BLADES (Continued)

2-35

s. Inspect for blade (23) protrusion from disc. Protrusion at rear face (28) shall not exceed 0.010 inch. Protrusion at forward face (29) shall not exceed following limits:

- (1) Second stage 0.015 inch.
- (2) Third stage 0.014 inch.
- (3) Fourth through seventh stage 0.018 inch.

INSPECT

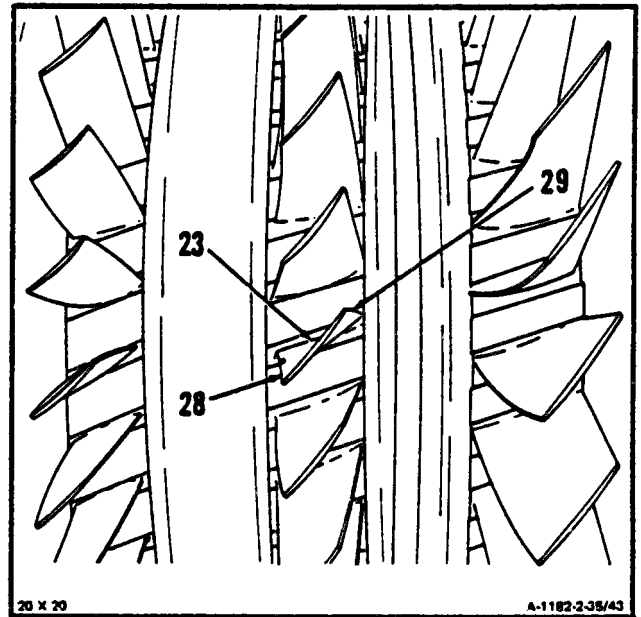

GO TO NEXT PAGE

- t. Check clearance between compressor housing (30) and compressor rotor blades. Use thickness gage (13). Check right and left sides of compressor housing (30). Tip clearance shall be 0.016 inch minimum for all second through seventh stages.

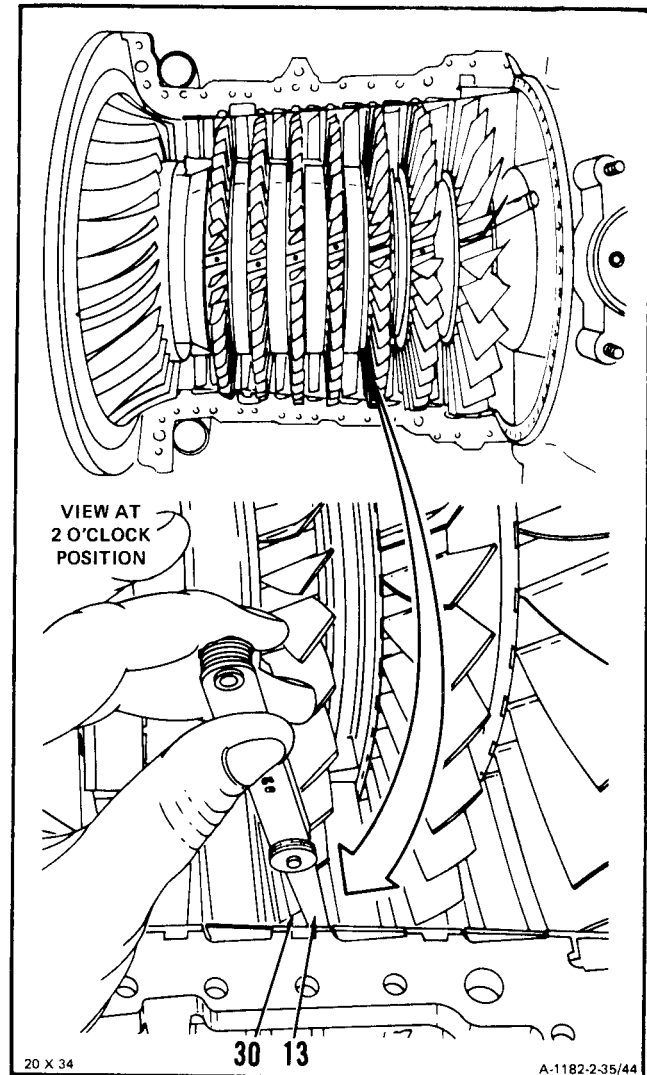

INSPECT

GO TO NEXT PAGE

2-35 INSTALL COMPRESSOR ROTOR BLADES (Continued)

2-35

- u. Inspect first and second stage compressor blades for erosion as in illustration.

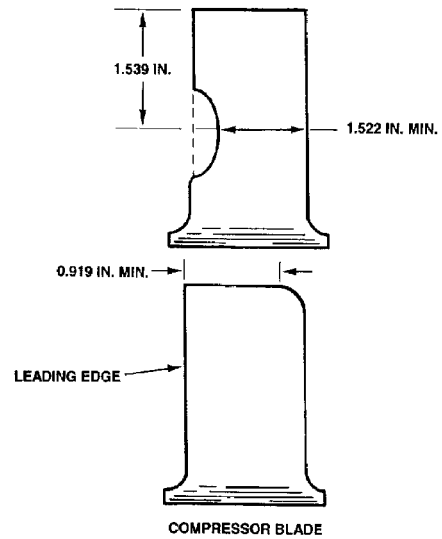

Compressor Blade (First and Second Stages) – Erosion Limits

MS019510

- v. Inspect third through seventh stage compressor blades for erosion as in illustration.

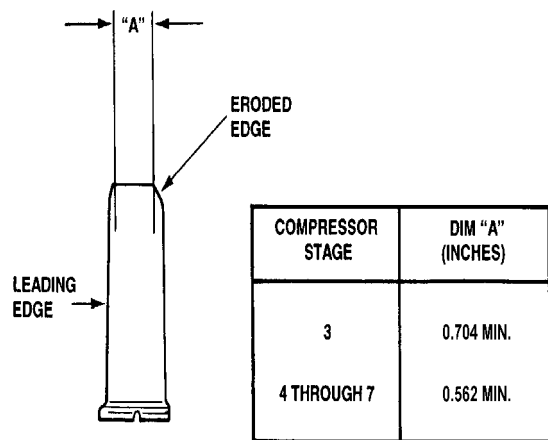

Compressor Blade (Third Through Seventh Stages) – Erosion Limits

MS019511

INSPECT

GO TO NEXT PAGE

FOLLOW-ON MAINTENANCE:

- Install Upper Compressor Housing (Task 2-24).
- Install Compressor Bleed Band (Task 2-13).
- Install Interstage Air-Bleed Actuator (Task 2-7).
- Install Main Fuel Filter and Bracket (Task 6-35).
- Install Starter Drive Assembly (Task 5-16).
- Install Oil Filler Assembly and Oil Filler Strainer (Task 8-22).
- Install Ignition Exciter (Task 7-15).
- Install In-Line Fuel Filter Assembly (Task 6-41).
- Install Oil Cooler Assembly (Task 8-11).
- Service Engine Oil System (Task 1-74).

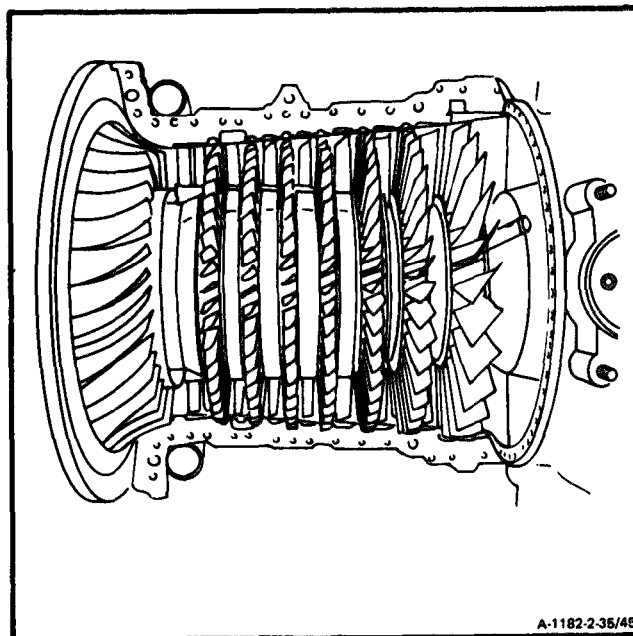
**END OF TASK**

Section VII. AIR DIFFUSER ASSEMBLY - MAINTENANCE PROCEDURES

2-36 REMOVE AIR DIFFUSER ASSEMBLY (AVIM)

2-36

INITIAL SETUP

Applicable Configurations:

All

Tools:

Powerplant Mechanic's Tool Kit,
NSN 5180-00-323-4944
Mechanical Puller (T25)

Materials:

None

Personnel Required:

68B10 Aircraft Powerplant Repairer

Equipment Condition:

Engine Oil System Drained (Task 1-75)
Combustion Section and Power Turbine
Removed (Task 3-5)
Second Turbine Disc Assembly Removed
(Task 4-53)
Second Turbine Nozzle, Spacer and Case
Removed (Task 4-57)
First Turbine Disc Assembly Removed
(Task 4-62)
First Turbine Nozzle Removed
(Task 4-67)
Diffuser Curl Removed (Task 4-73)

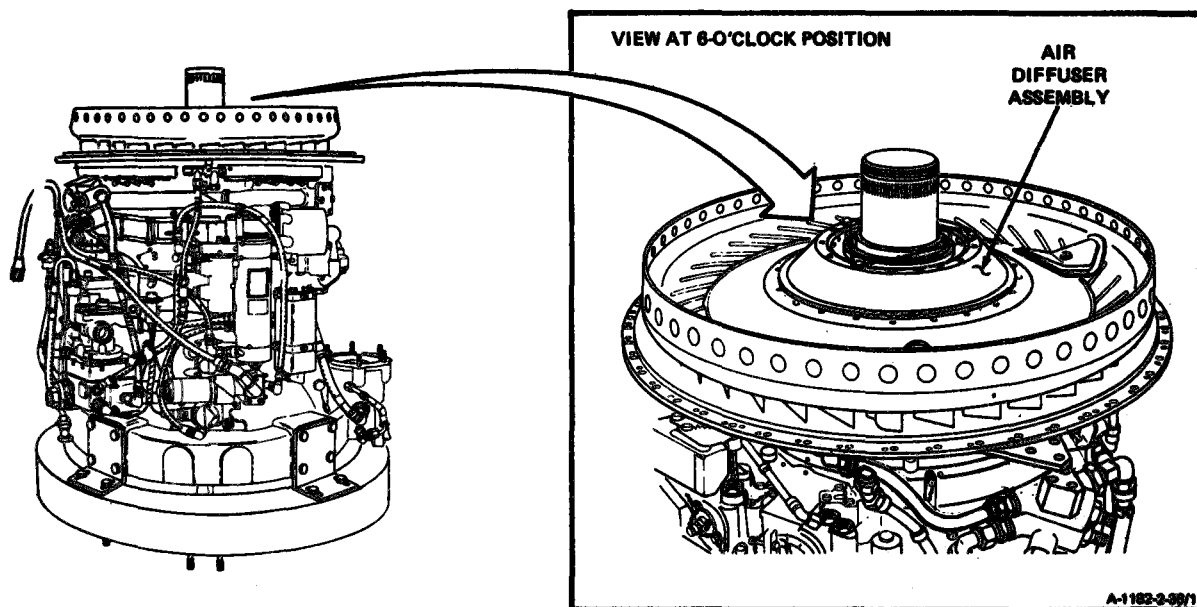

GO TO NEXT PAGE

1. Disconnect hose assembly (1).

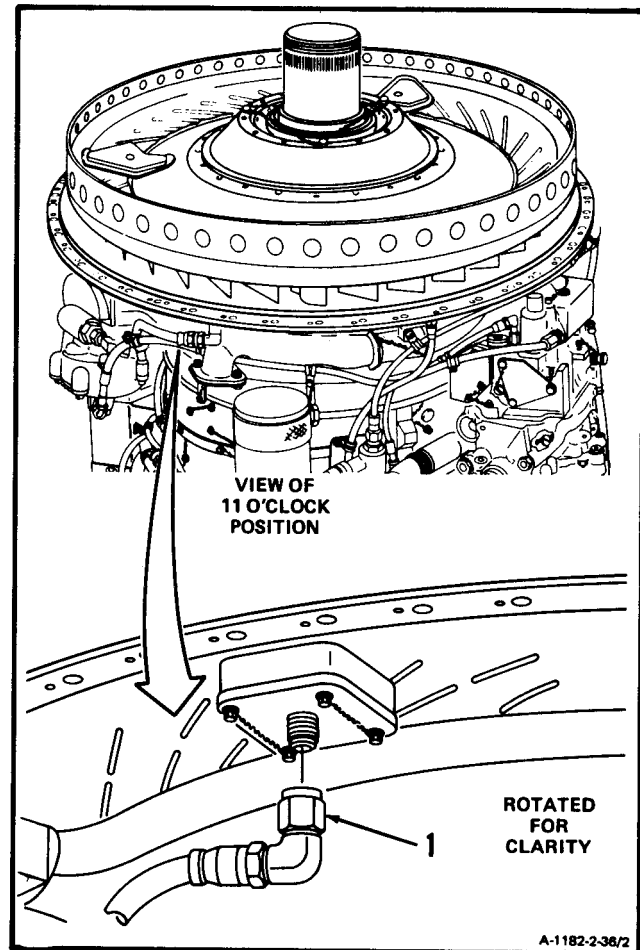

GO TO NEXT PAGE

2-36 REMOVE AIR DIFFUSER ASSEMBLY (AVIM) (Continued)

2-36

2. Remove lockwire and **disconnect hose assembly (2).**

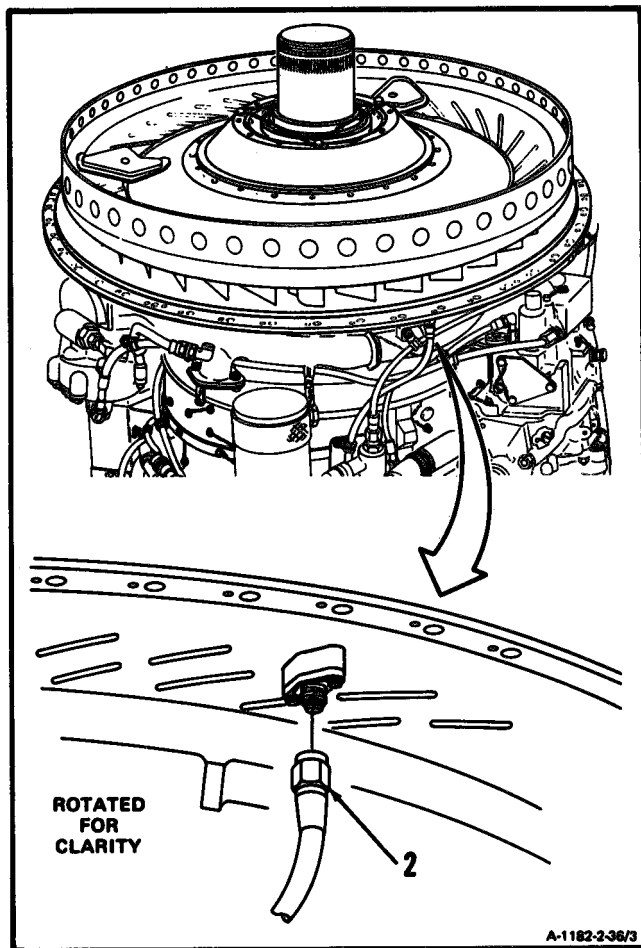

GO TO NEXT PAGE

- 3. Disconnect hose assembly (3).
- 4. Check for evidence of oil leakage around pressure connector (4) and welded area (5). If evidence of leakage is found, have an aircraft powerplant inspector examine air diffuser assembly (Ref. Task 2-38).

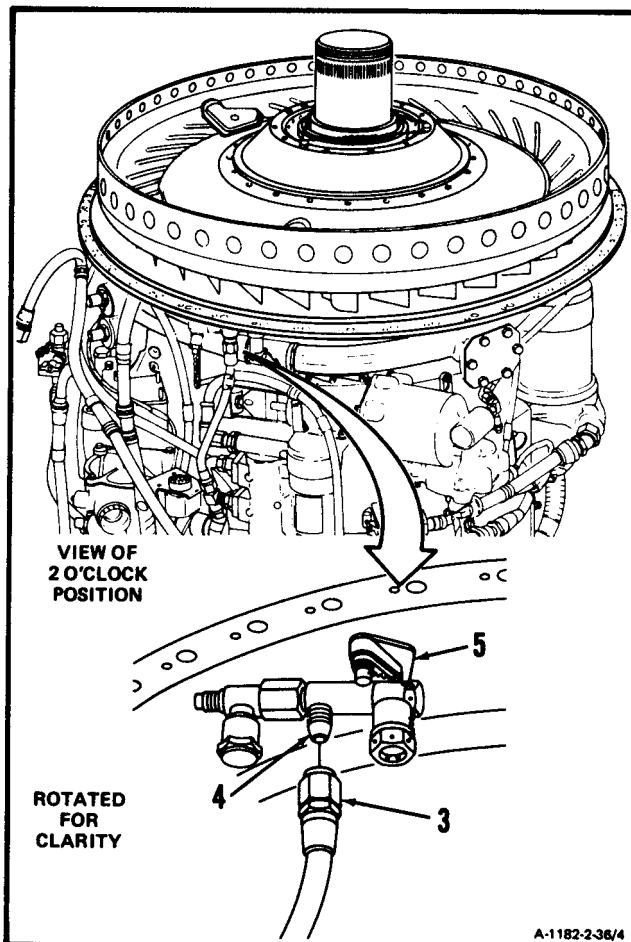

- 5. Disconnect hose assembly (6).
- 6. Check for evidence of oil leakage around scavenge connector (7) and welded area (8). If evidence of leakage is found, have an aircraft powerplant inspector examine air diffuser assembly (Ref. Task 2-38).

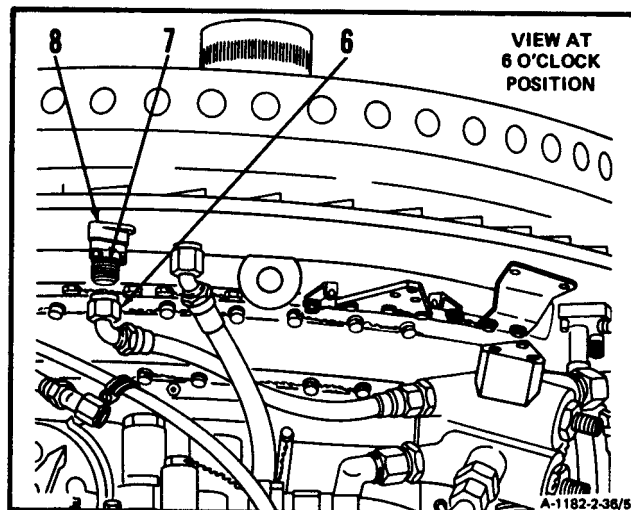

GO TO NEXT PAGE

7. Remove lockwire, bolt (9), and bracket (10).

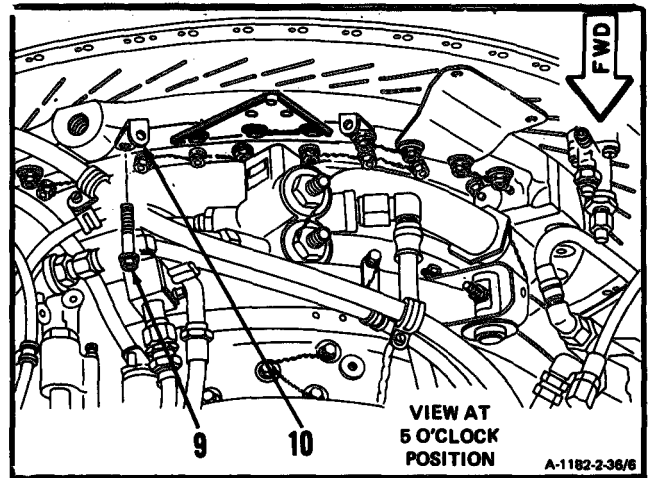

8. Remove lockwire, three bolts (9), and bracket (11).

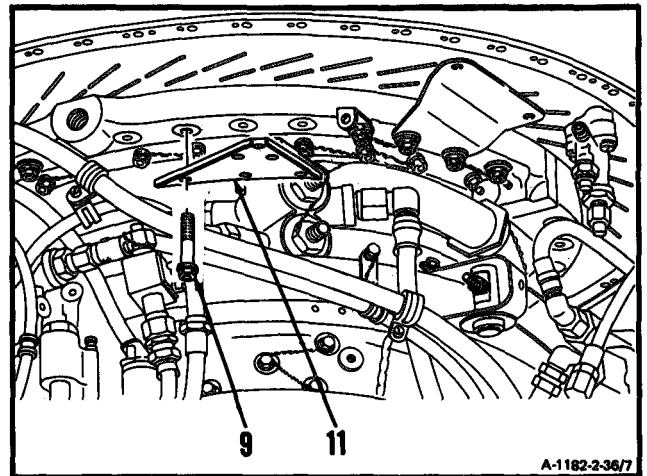

9. Remove lockwire, bolt (9), and bracket (12).

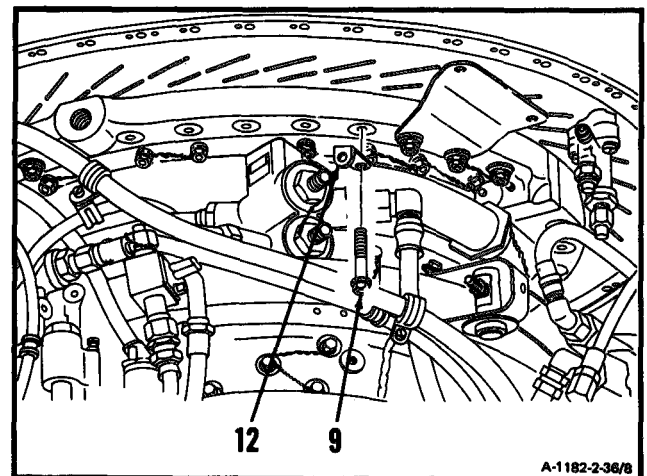

GO TO NEXT PAGE

10. Remove lockwire, two bolts (9), and bracket (13).

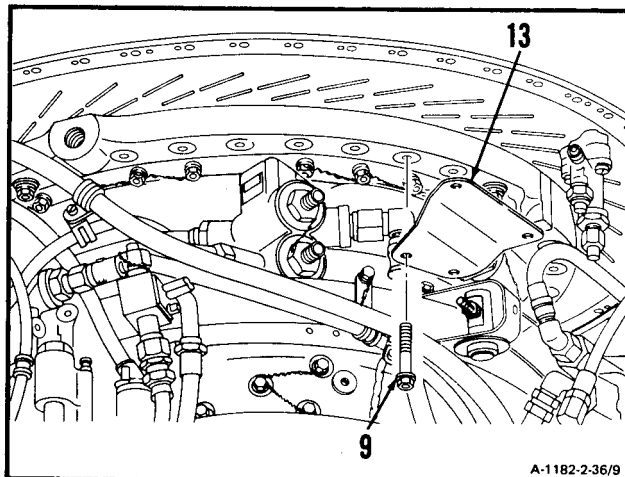

11. Remove lockwire, 25 bolts (9) and washers (14).

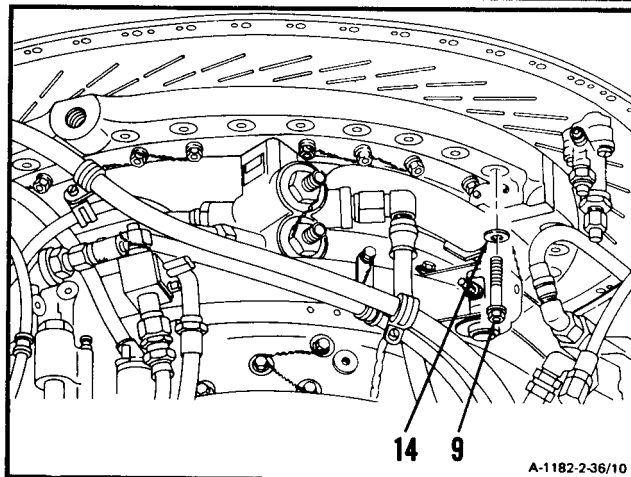

12. Remove three bolts (15) from air diffuser assembly (16).

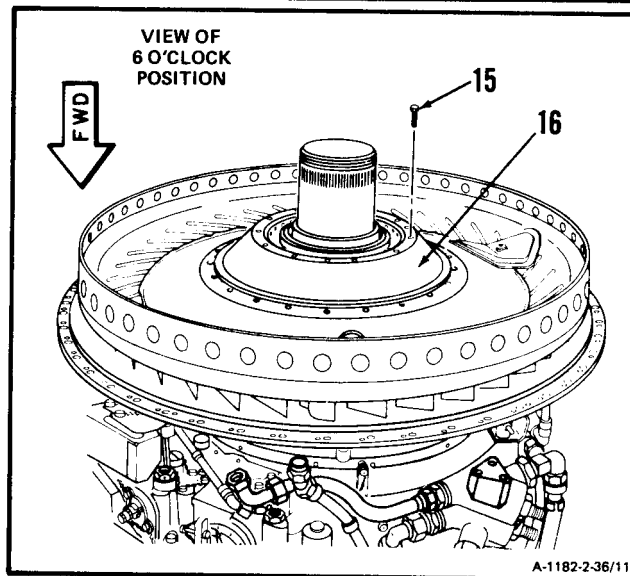

GO TO NEXT PAGE

2-36 REMOVE AIR DIFFUSER ASSEMBLY (AVIM) (Continued)

2-36

13. **Position puller (T25) (17)** on No. 2 bearing housing (18).
14. **Screw three bolts (19)** into air diffuser assembly holes (20).

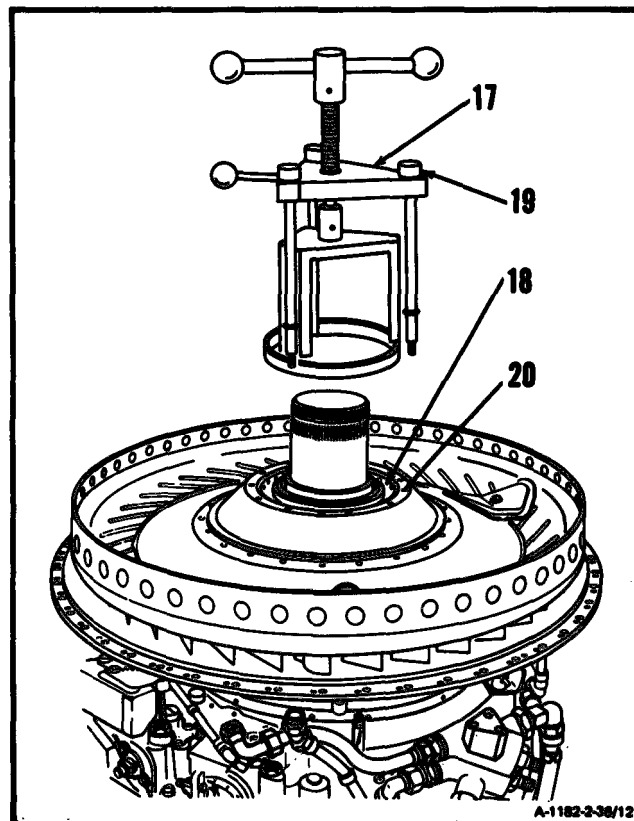

15. **Turn puller handle (21) clockwise** until air diffuser assembly (16) is loose.

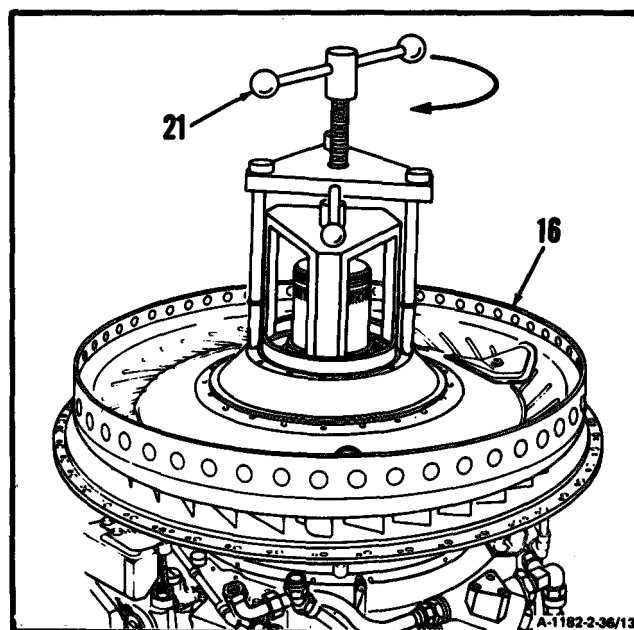

GO TO NEXT PAGE

16. Turn puller handle (21) counterclockwise until puller handle (21) is loose.
17. Unscrew three bolts (19) and remove puller (T25) (17) from No. 2 bearing housing (18).

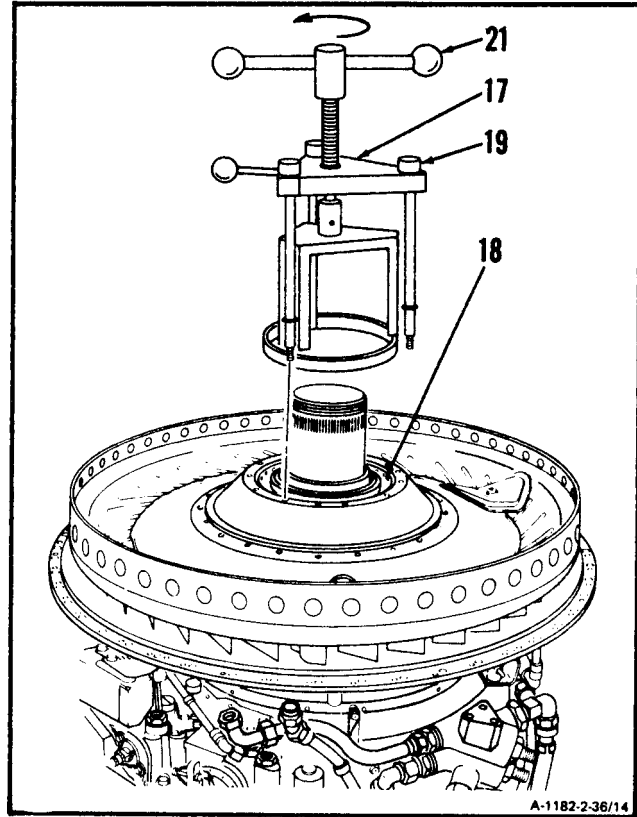

GO TO NEXT PAGE

2-36 REMOVE AIR DIFFUSER ASSEMBLY (AVIM) (Continued)

2-36

NOTE

Metal gaskets may stick to underside of air diffuser housing.

18. Remove air diffuser assembly (20), and two gaskets (22 and 23).

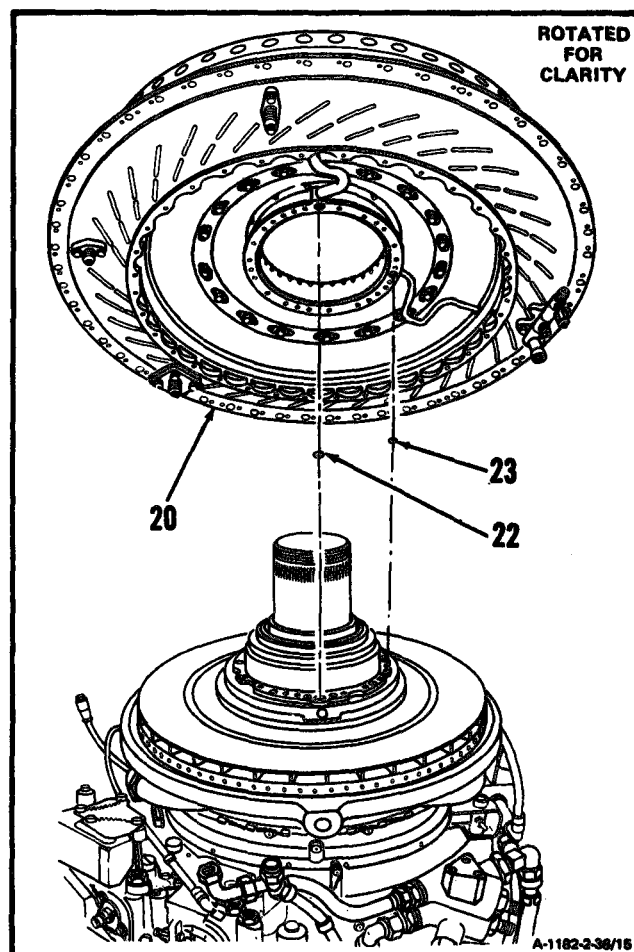

FOLLOW-ON MAINTENANCE:

None

END OF TASK

2-37 CLEAN AIR DIFFUSER ASSEMBLY (AVIM)

2-37

INITIAL SETUP

Applicable Configurations:

All

Tools:

Fiber Brush
Goggles
Compressed Air Source

Materials:

Gloves (E20)
Methyl Ethyl Ketone (E36)

Personnel Required:

68B10 Aircraft Powerplant Repairer

Equipment Condition:

Off Engine Task
Engine Oil System Drained (Task 1-75)
Combustion Section and Power Turbine Removed (Task 3-5)
Second Turbine Disc Assembly Removed (Task 4-53)
Second Turbine Nozzle, Spacer and Case Removed (Task 4-57)
First Turbine Disc Assembly Removed (Task 4-62)
First Turbine Nozzle Assembly Removed (Task 4-67)
Diffuser Curl Removed (Task 4-73)
Air Diffuser Assembly Removed (Task 2-36)

General Safety Instructions:**WARNING**

Methyl ethyl ketone (E36) is flammable and toxic. It can irritate skin and cause burns. Use only in well-ventilated area, away from heat and open flame. In case of contact, immediately flush skin or eyes with water for at least 15 minutes. Get medical attention for eyes.

1. Clean air diffuser assembly (1) as follows:

- a. Wear gloves (E20) and goggles. Use methyl ethyl ketone (E36) and fiber brush.

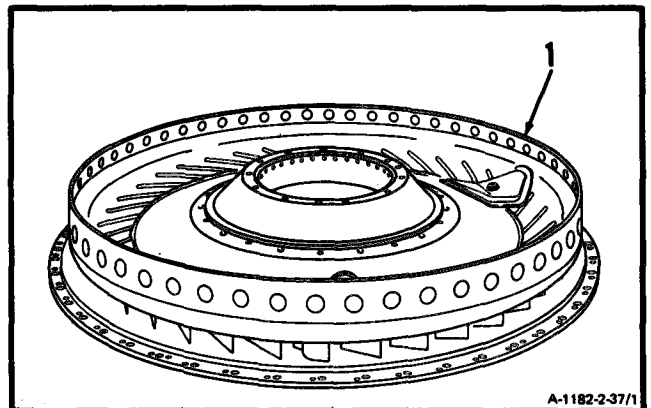

A-1182-2-37/1

GO TO NEXT PAGE

WARNING

When using compressed air for cleaning, use approved protective equipment for eyes and face. Do not use more than 30 psig air pressure. Do not direct air toward yourself or another person. Failure to comply could result in injury to eyes or skin. In case of injury, get medical attention.

- b. **Blow dry air diffuser assembly.** Use clean, dry compressed air.

FOLLOW-ON MAINTENANCE:

Inspect Air Diffuser Assembly (Task 2-38).

END OF TASK

INITIAL SETUP

Materials:
None

Applicable Configurations:
All

Personnel Required:
68B30 Aircraft Powerplant Inspector

Tools:
Technical Inspection Tool Kit,
NSN 5180-00-323-5114
Compressed Air Source
Goggles

Equipment Condition:
Off Engine Task

1. Inspect oil scavenge adapter mount boss (1) and pressure line connector mount boss (2). There shall be no more than two cracks per weld on each adapter. These cracks shall not be longer than 1/8-inch and must be separated by 1 -inch minimum.

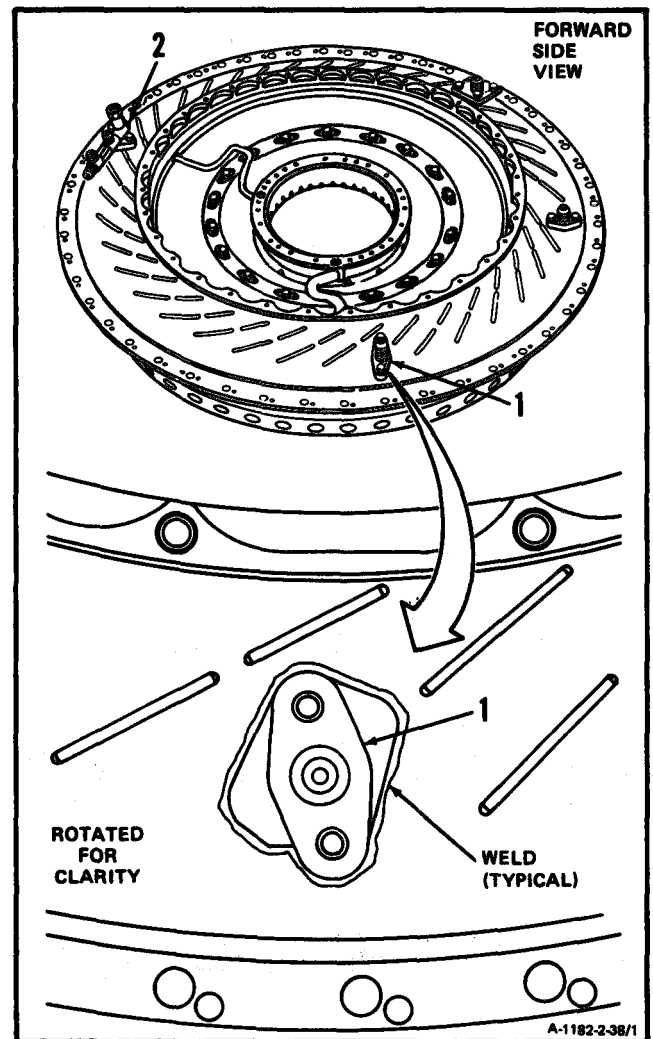

GO TO NEXT PAGE

2. **Inspect oil scavenge and pressure lines inner adapter plates (3 and 4).** There shall be no cracks in welds around the edge of the plates. There shall be no cracks in adapter plates (3 and 4).

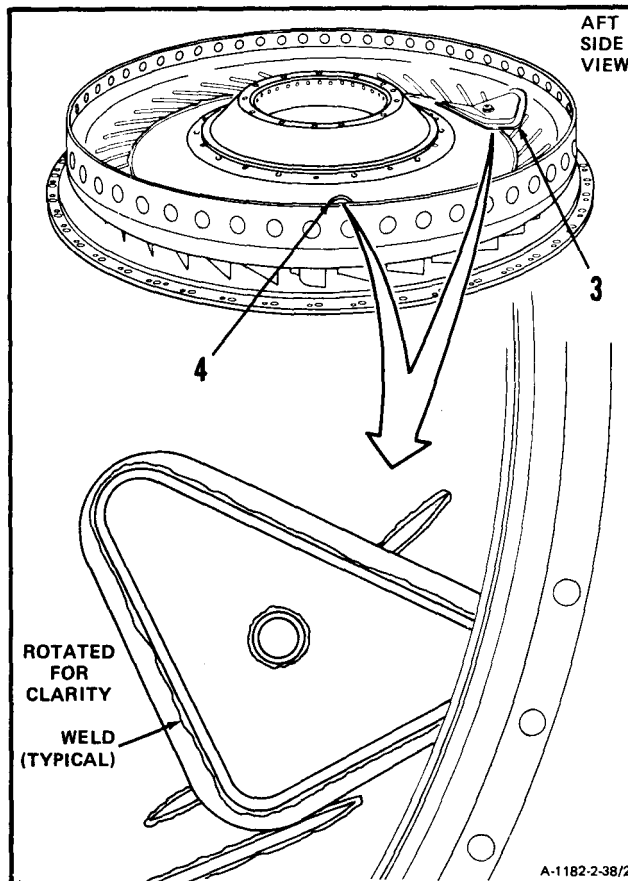

3. **Inspect pressure pickup connector (5) and adapter (6) mount bosses.** There shall be no cracks on boss longer than 1/8-inch or closer than 1-inch

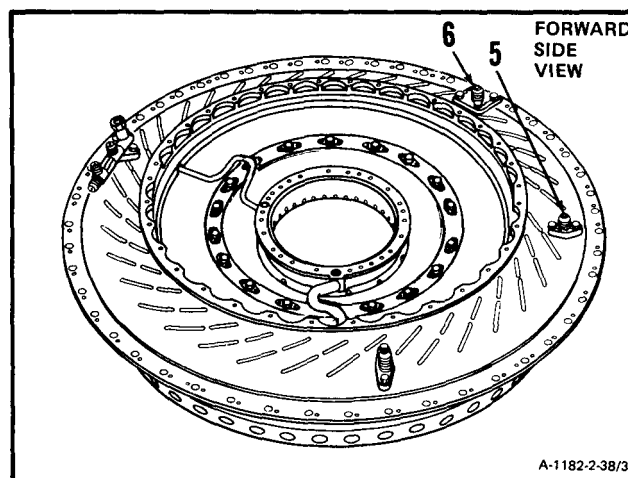

GO TO NEXT PAGE

4. Inspect oil tubes (7 and 8) as follows:

- a. There shall be no cracks.

WARNING

When using compressed air for cleaning, use approved protective equipment for eyes and face. Do not use more than 30 psig air pressure. Do not direct air toward yourself or another person. Failure to comply could result in injury to eyes or skin. In case of injury, get medical attention.

- b. There shall be no clogged oil tubes. Wear goggles. Apply compressed air to oil scavenge adapter (1) and pressure line connector (2). Use clean, dry compressed air. Feel for air flow at tube ends (9).
- c. There shall be no chafes (10), nicks (11) or pits (12) deeper than 0.012 inch on tube (7). Any length chafe, nick or pit is acceptable.
- d. There shall be no chafes (13), nicks (14) or pits (15) deeper than 0.015 inch on tube (8). Any length chafe, nick or pit is acceptable.

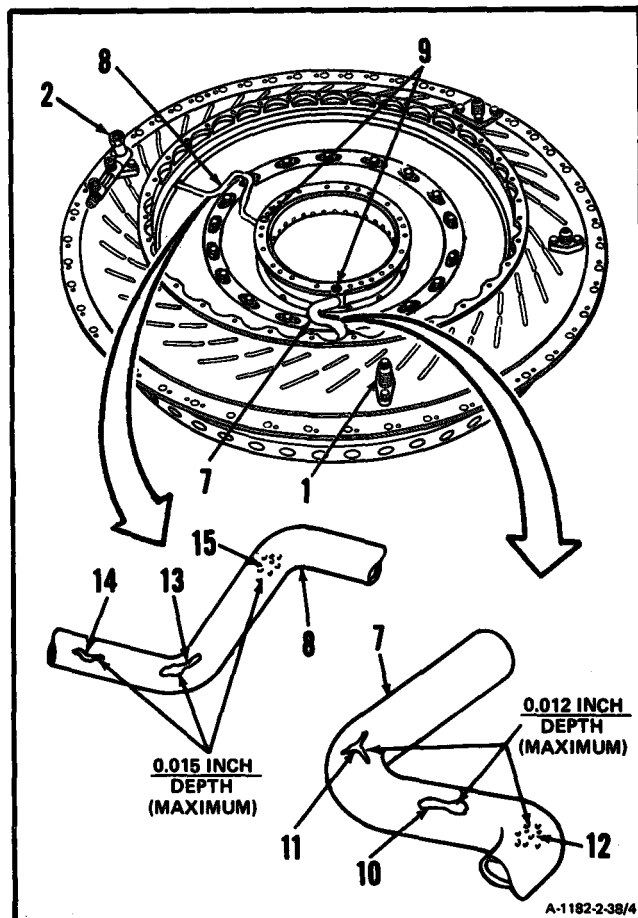

- 5. Inspect bolts (16) and screws (17) on connector (2) and adapters (1 and 6). There shall be no loose bolts or screws. There shall be no broken, loose or improperly installed lockwire.

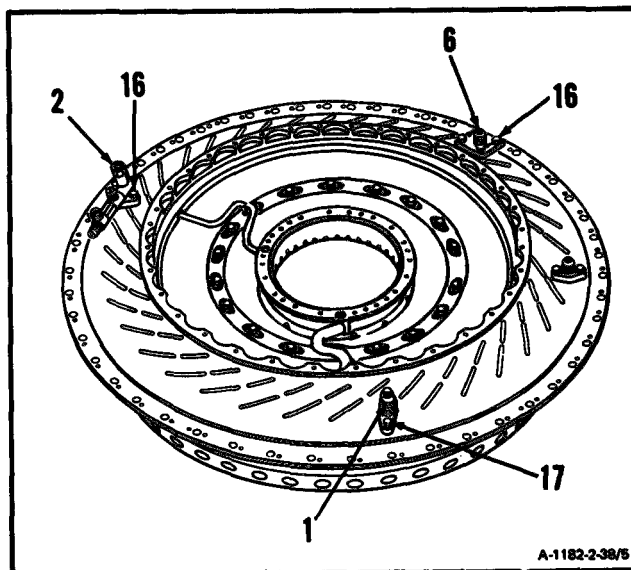

GO TO NEXT PAGE

6. **Inspect connector (2) and adapters (1 and 6).**
 There shall be no cracked nipples (18). There shall be no evidence of leakage. There shall be no gap (19) between boss (20) and adapter.

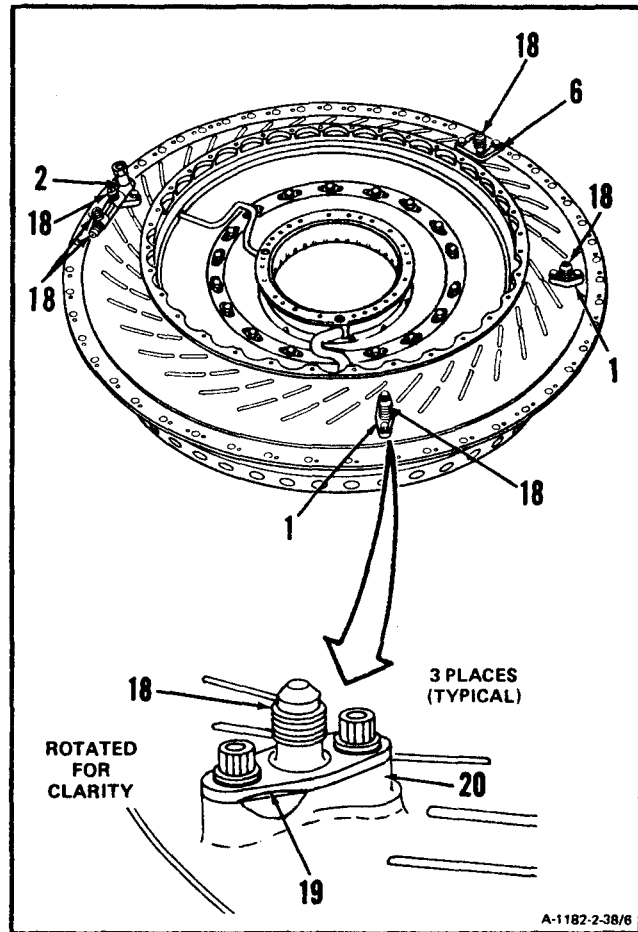

GO TO NEXT PAGE

7. Inspect four air diffuser assembly air and oil transfer vanes (21).

- a. There shall be no nicks, dents or pits.
- b. There shall be no cracks (22) in brazement (23) wider than 1/32-inch or longer than 1/2-inch. Any size void in brazement (23) is acceptable.

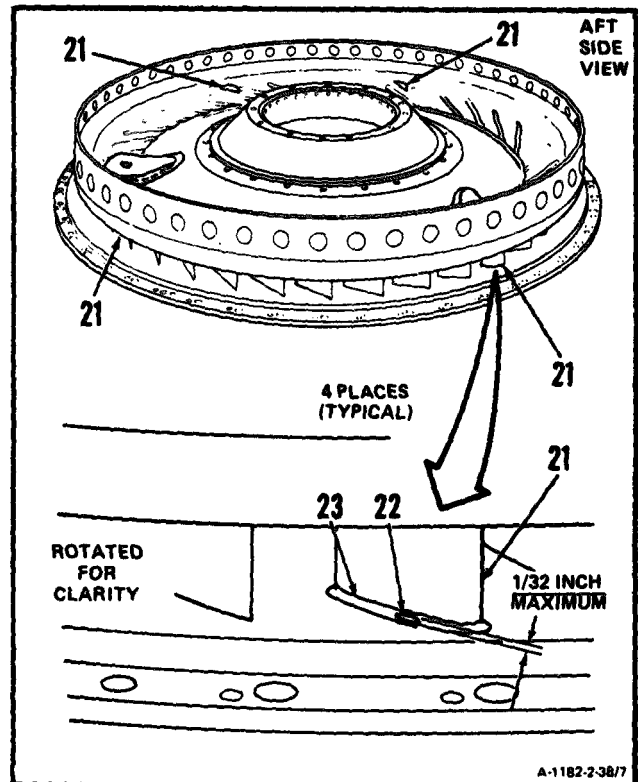

GO TO NEXT PAGE

8. Inspect 38 air diffuser assembly vanes (24).

- a. There shall be no nicks (25), dents (26) or pits (27) in airfoil surface (28) deeper than 1/32-inch. These nicks (25), dents (26) or pits (27) shall not be larger than 1/8-inch diameter or separated by less than 1/4-inch.
- b. There shall be no nicks (29), dents (30) or pits (31) in trailing edge (32) deeper than 3/32-inch. There shall be no more than three 3/32-inch deep nicks (29), dents (30) or pits (31) in trailing edges of any vane (24). These nicks (29), dents (30) or pits (31) shall be separated by not less than 3/16-inch. There shall be no more than 20 vanes (24) with these nicks (29), dents (30), or pits (31). Burrs on vanes (24) are acceptable provided they are blend repaired.
- c. There shall be no cracks (33) in brazement (34) wider than 1/32-inch or longer than 1/2-inch. Any void in brazement (34) is acceptable.

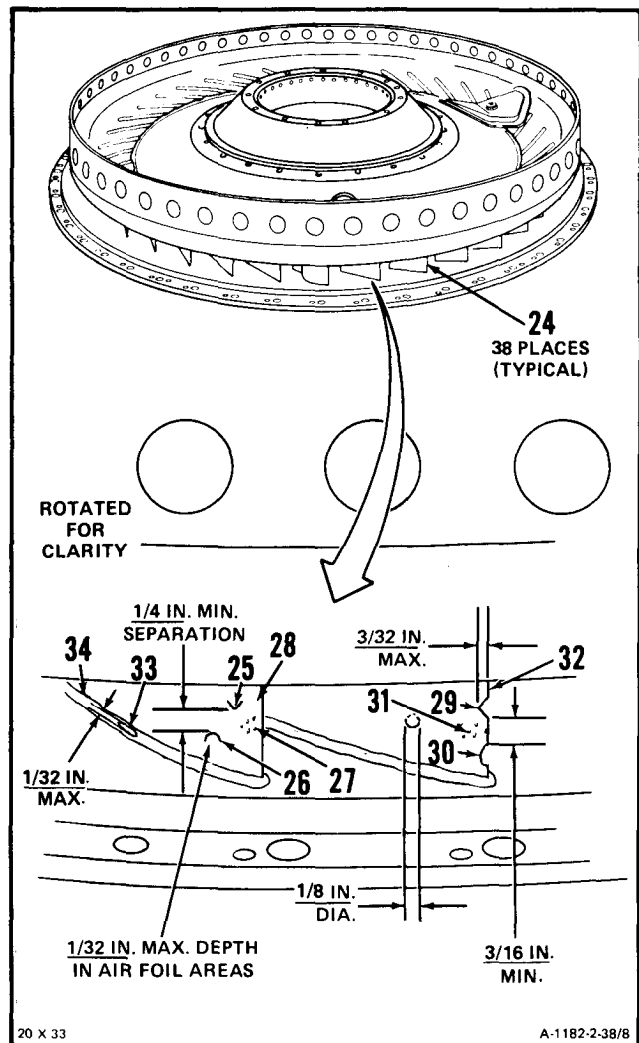

GO TO NEXT PAGE

9. Inspect 38 air diffuser assembly vanes (24).

- a. There shall be no erosion (35) of vane leading edge (36) deeper than 3/32-inch.
- b. There shall be no nicks (37), dents (38) or pits (39) in airfoil surface (40) deeper than 1/32-inch. These nicks (37), dents (38) or pits (39) shall not be larger than 1/8-inch diameter or separated by less than 1/4-inch.
- c. There shall be no nicks (41), dents (42) or pits (43) in leading edge (36) deeper than 3/32-inch. There shall be no more than three 3/32-inch deep nicks (41), dents (42) or pits (43) in leading edges of any vane (24). These nicks (41), dents (42) or pits (43) shall be separated by not less than 3/16-inch. There shall be no more than 20 vanes (24) with these nicks (41), dents (42) or pits (43). Burrs on vanes (24) are acceptable provided they are blend repaired.
- d. There shall be no cracks (44) in brazement (45) wider than 1/32-inch or longer than 1/2-inch. Any void in brazement (45) is acceptable.

FOLLOW-ON MAINTENANCE:

None

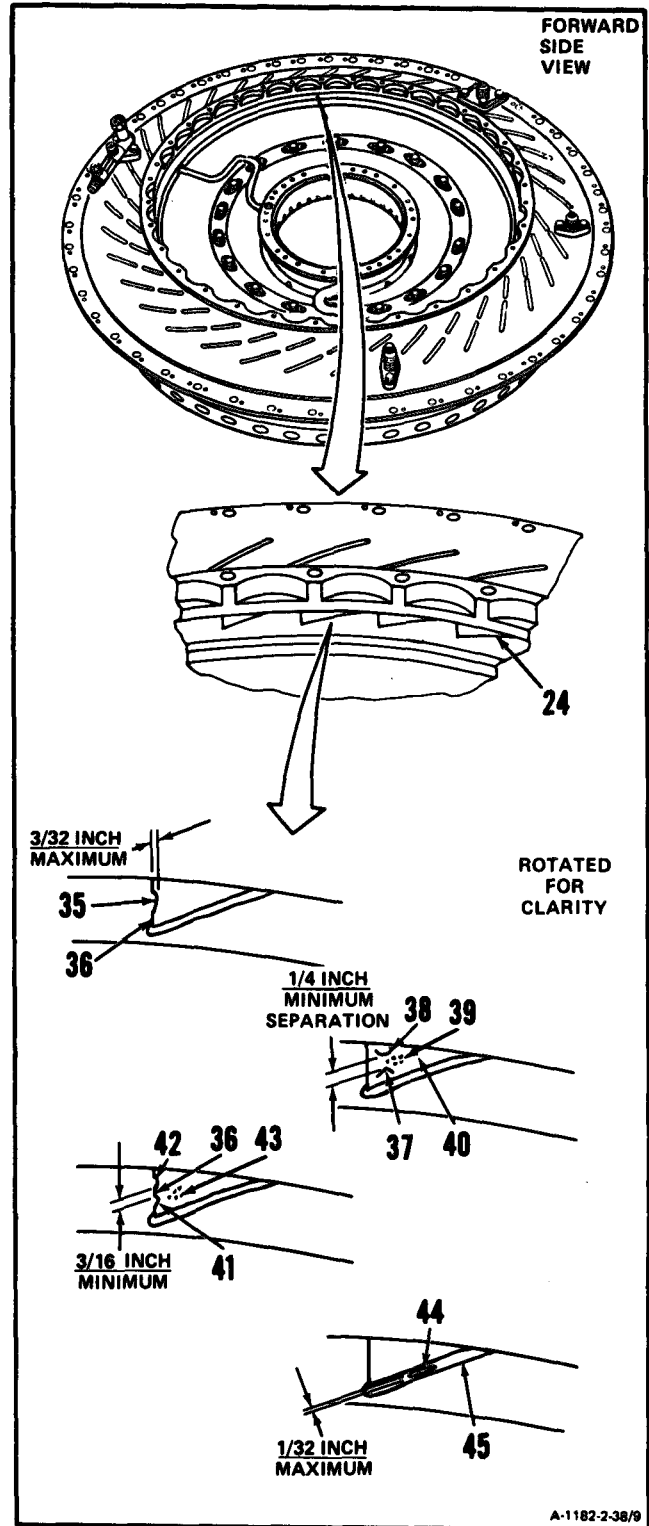

END OF TASK

2-39 REPAIR AIR DIFFUSER ASSEMBLY (AVIM)**2-39****INITIAL SETUP****Applicable Configurations:**

All

Tools:

Powerplant Mechanic's Tool Kit,
NSN 518000-323-4944
Technical Inspection Tool Kit,
NSN 5180-00-323-5114
Goggles
Micrometer Depth Gage
Compressed Air Source

Materials:

Crocus Cloth (EI 5)

Personnel Required:

68B10 Aircraft Powerplant Repairer
68B30 Aircraft Powerplant Inspector

References:

Task 8-76
Task 8-77
Task 8-79

Equipment Condition:

Off Engine Task

1. Repair nicks, burrs, dents and pits on vanes (1) by blend repairing not to exceed the following limits.
 - a. Random nicks, dents or pits to 1/32-inch maximum.
 - b. Diameter of defects shall not be greater than 1/8-inch with a minimum of 1/4-inch between defects.
 - c. Trailing edge nicks, dents or pits up to 3/32-inch maximum depth. There shall be no more than three per vane. There shall be no more than 20 vanes with these defects. These defects shall be separated by not less than 3/16-inch.

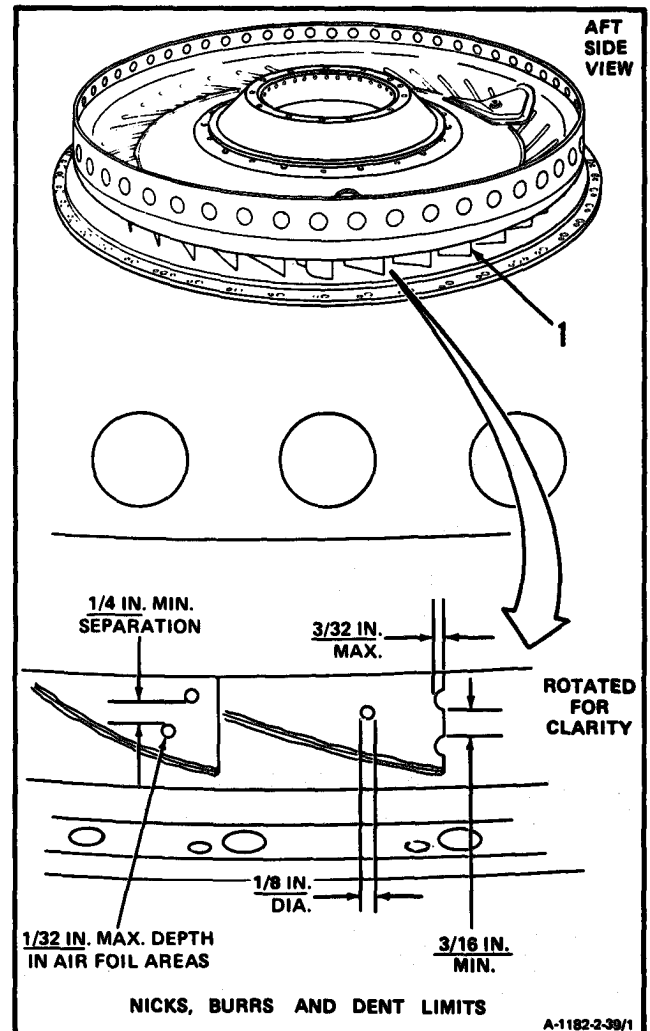
**GO TO NEXT PAGE**

- d. Leading edge nicks, dents or pits up to 3/32-inch maximum depth. There shall be no more than three per vane. There shall be no more than 20 vanes with these defects. These defects shall be separated by not less than 3/16-inch.

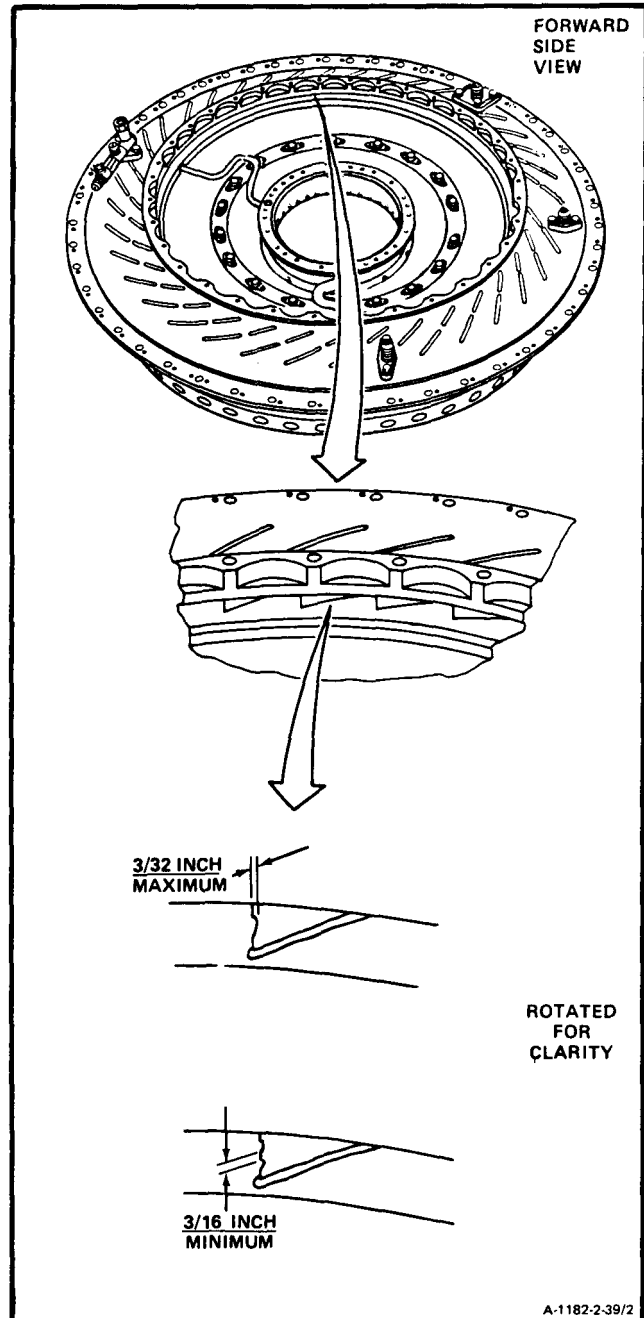

GO TO NEXT PAGE

2-39 REPAIR AIR DIFFUSER ASSEMBLY (AVIM) (Continued)

2-39

2. Wear goggles. Clear contaminated oil passages (2 and 3) as follows:

- a. Remove No. 2 bearing pressure oil strainer (Ref. Task 8-76).

WARNING

When using compressed air for cleaning, use approved protective equipment for eyes and face. Do not use more than 30 psig air pressure. Do not direct air toward yourself or another person. Failure to comply could result in injury to eyes or skin. In case of injury, get medical attention.

- b. Apply compressed air to tube ends (4). Use clean, dry compressed air. Feel for air flow at scavenge adapter (5) and pressure line connector (6).
- c. Clean No. 2 bearing pressure oil strainer (Ref. Task 8-77).
- d. Install No. 2 bearing pressure oil strainer (Ref. Task 8-79).

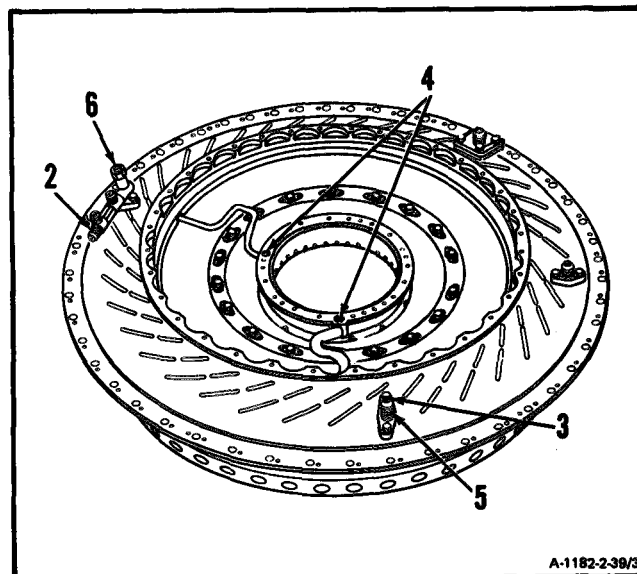

GO TO NEXT PAGE

3. Repair oil tubes (7 and 8) as follows:

- a. For oil tube (7), remove sharp edges of chafes (9), nicks (10) or pits (11) up to 0.012 inch. Use crocus cloth (E15).
- b. For oil tube (8), remove sharp edges of chafes (12), nicks (13) or pits (14) up to 0.015 inch. Use crocus cloth (E15).

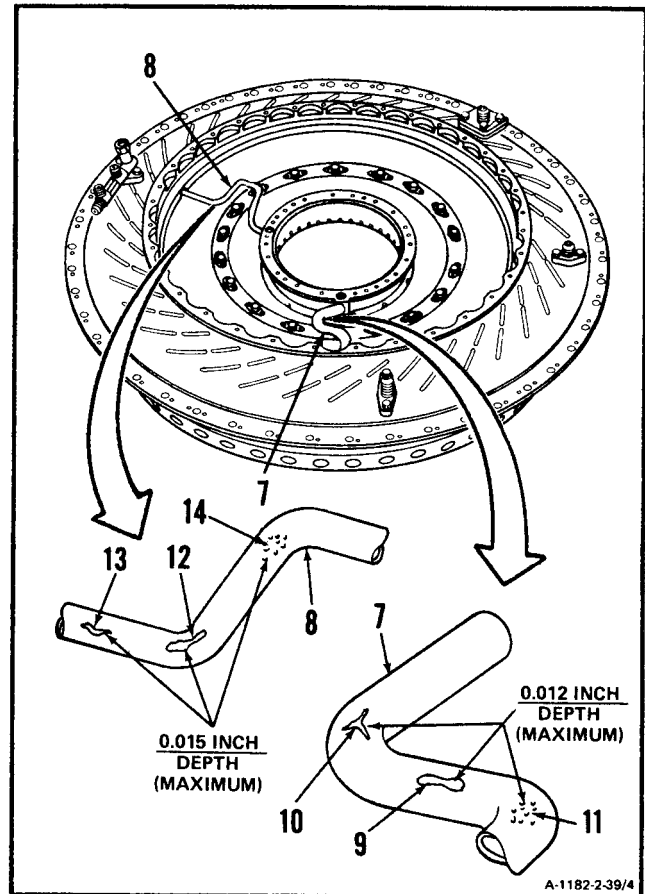
**INSPECT****FOLLOW-ON MAINTENANCE:**

None

END OF TASK

2-40 REPAIR AIR DIFFUSER ASSEMBLY

2-40

INITIAL SETUP**Applicable Configurations:**
All**Tools:**

Powerplant Mechanic's Tool Kit,
NSN 5180-00-323-4944
Technical Inspection Tool Kit,
NSN 5180-00-323-5114

Materials:

Lockwire (E28)
Lockwire (E29)

Parts:

Packings
Seal Ring

Personnel Required:

68B10 Aircraft Powerplant Repairer
68B30 Aircraft Powerplant Inspector

References:

TM 55-2840-254-23P

1. **Tighten loose bolts (1)** on pressure connector (2) as follows:
 - a. Remove lockwire from bolts (1).
 - b. Tighten bolts (1).
 - c. Lockwire bolts (1). Use lockwire (E29).

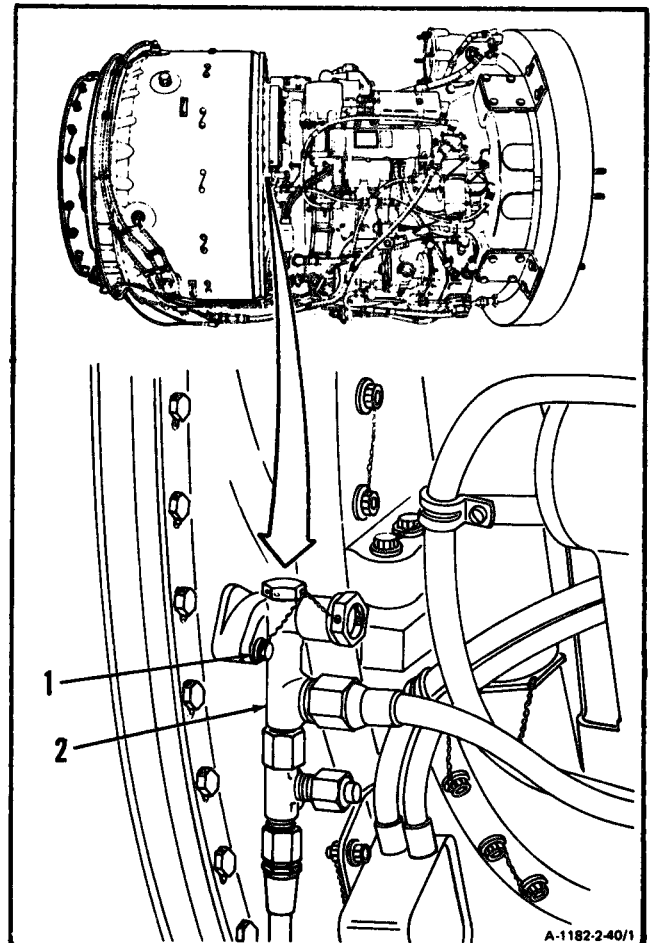

GO TO NEXT PAGE

2. **Tighten loose screws (3) and bolts (4 and 5)** on adapters (6 and 7) and union (8) as follows:
- Remove lockwire from screws (3) and bolts (4 and 5).
 - Tighten screws (3) and bolts (4 and 5).
 - Lockwire screws (3). Use lockwire (E28).
 - Lockwire bolts (4 and 5). Use lockwire (E29).

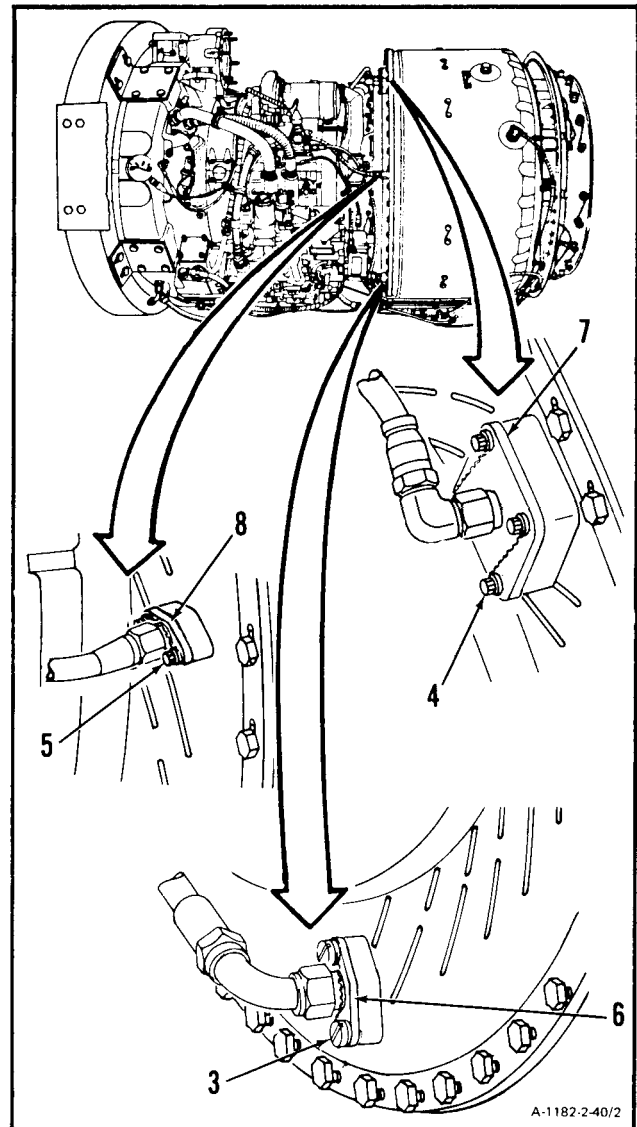

GO TO NEXT PAGE

3. Repair leaking or cracked pressure connector (2)
as follows:

- a. Disconnect hose assembly (9) from pressure connector (2).

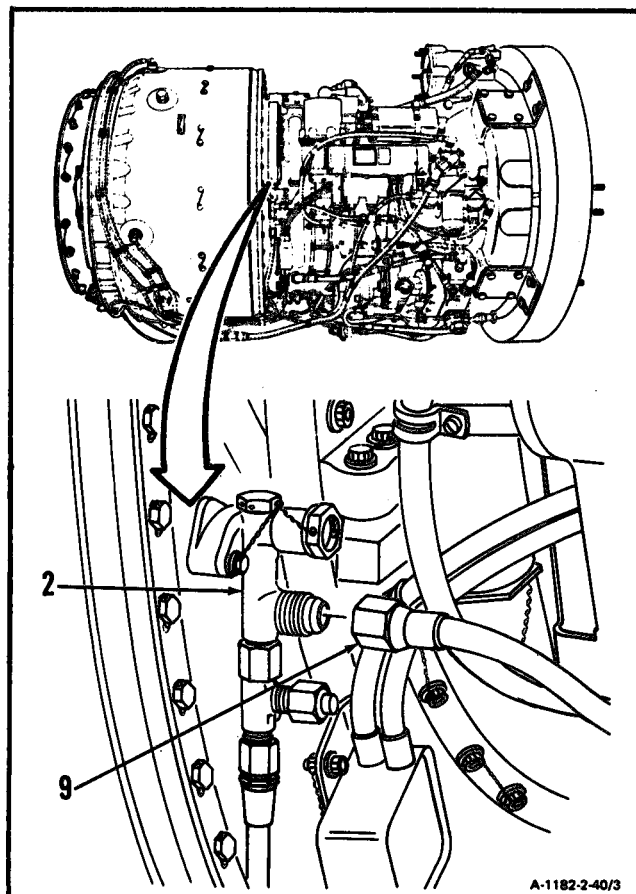

GO TO NEXT PAGE

- b. Disconnect tee and snubber (10) from pressure connector (2).

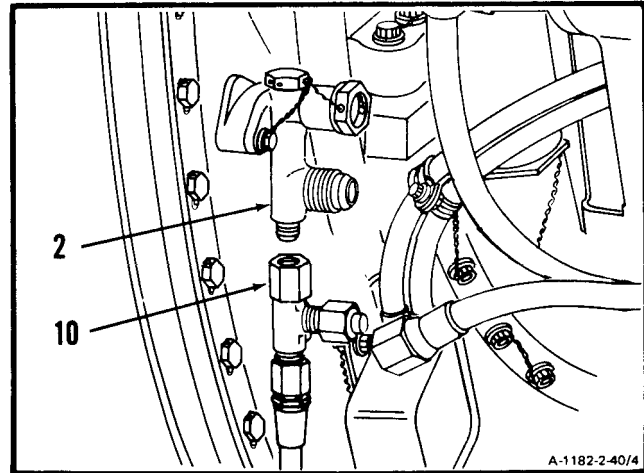

- c. Remove lockwire and two bolts (1).
- d. Remove pressure connector (2) and packing (11).
- e. Install packing (11), serviceable pressure connector (2), and two bolts (1).
- f. Lockwire two bolts (1). Use lockwire (E29).

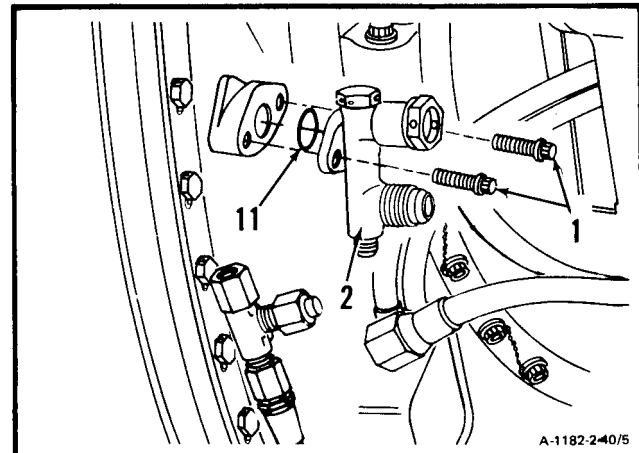

- g. Connect tee and snubber (10) to pressure connector (2).

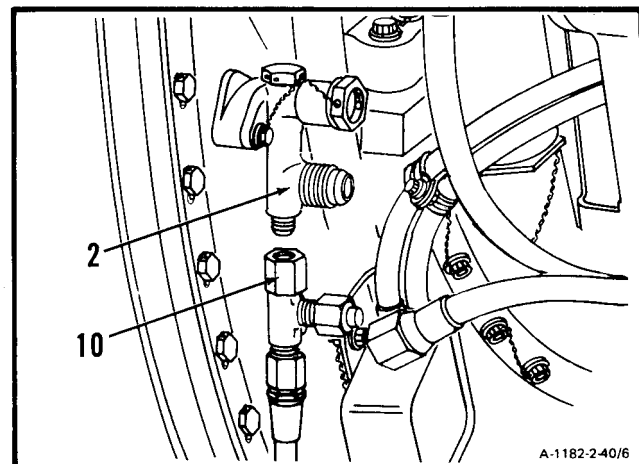

GO TO NEXT PAGE

- h. Connect hose assembly (9) to pressure connector (2).

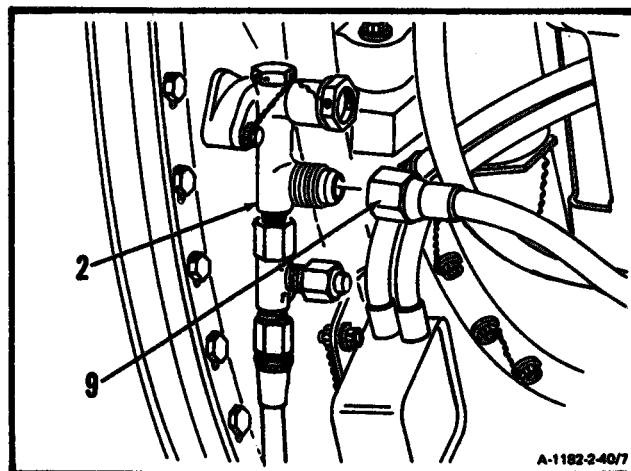

4. Repair leaking or cracked adapter (6) as follows:

- a. Disconnect hose assembly (12) from adapter (6).

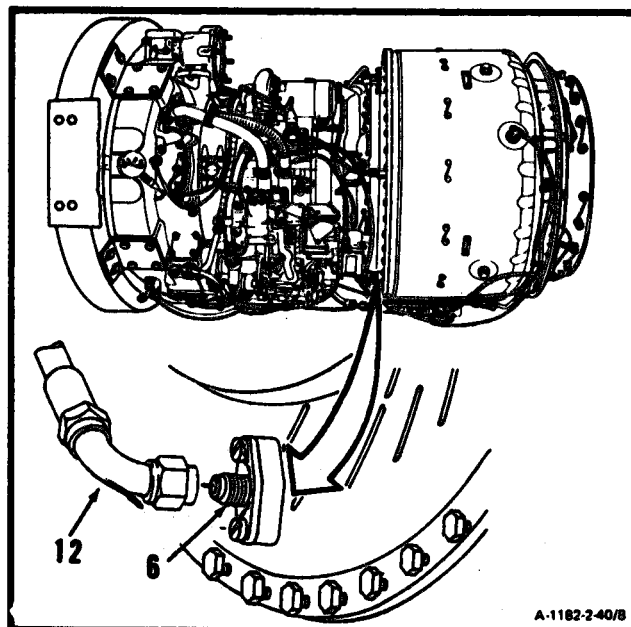

GO TO NEXT PAGE

- b. Remove lockwire, two screws (3), and washers (13).
- c. Remove adapter (6) and packing (14).
- d. Install packing (14), serviceable adapter (6), and two washers (13) and screws (3).
- e. Lockwire two screws (3). Use lockwire (E29).

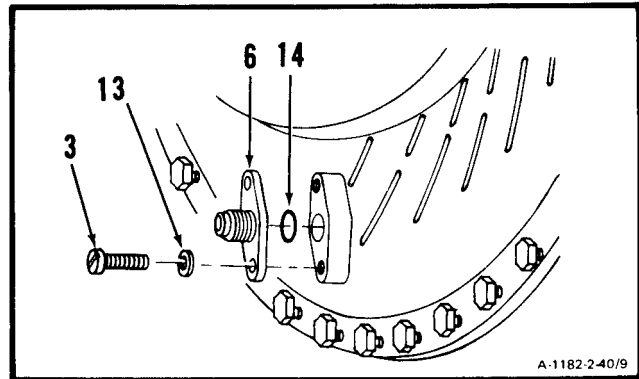

- f. Connect hose assembly (12) to adapter (6).

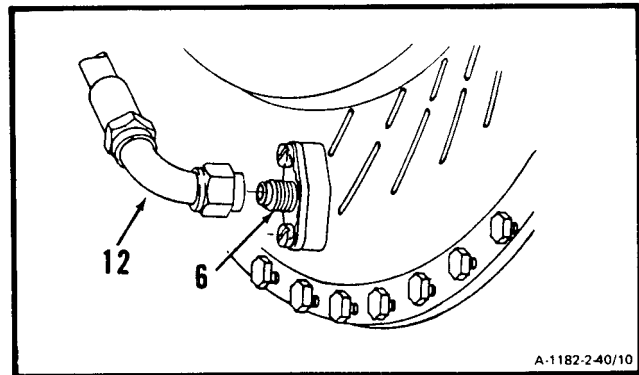

5. Repair leaking or cracked adapter (7) as follows:

- a. Disconnect hose assembly (15) from adapter (7).

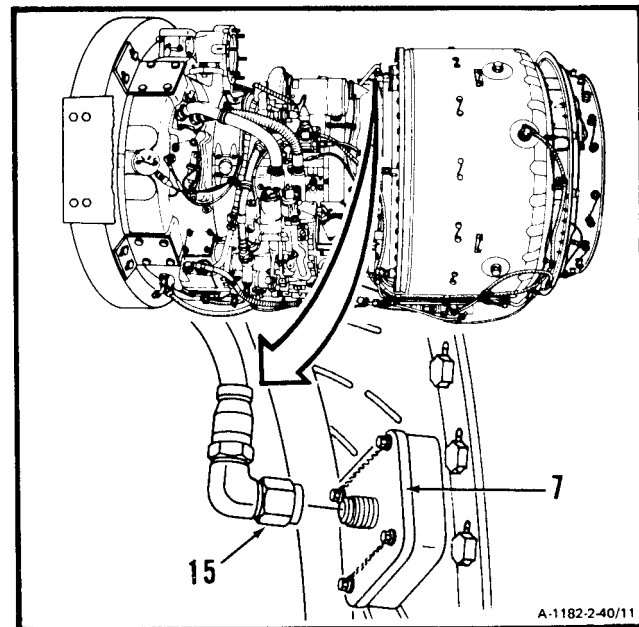

GO TO NEXT PAGE

2-40 REPAIR AIR DIFFUSER ASSEMBLY (Continued)

2-40

- b. Remove lockwire and four bolts (4).
- c. Remove adapter (7) and packing (16).
- d. Install packing (16), serviceable adapter (7) and four bolts (4).
- e. Lockwire four bolts (4). Use lockwire (E29).

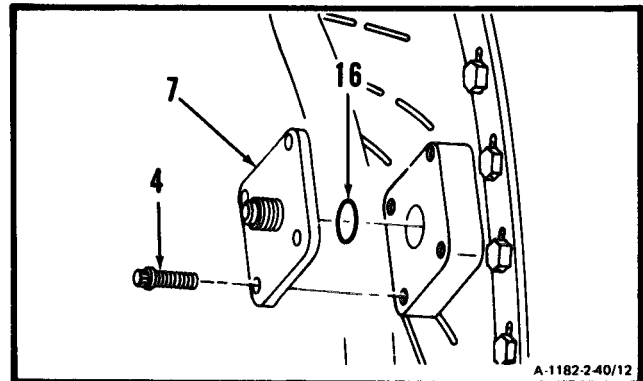

- f. Connect hose assembly (15) to adapter (7).

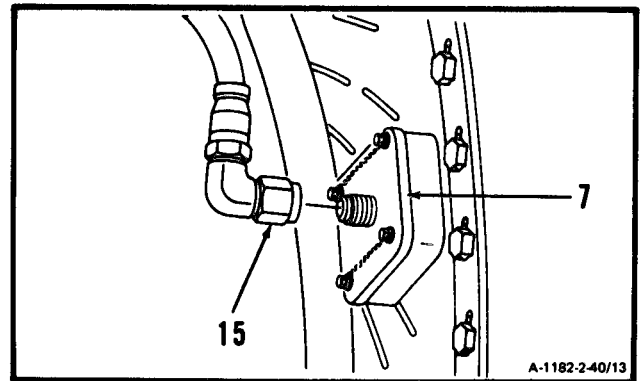

6. Repair leaking or cracked union (8) as follows:

- a. Remove lockwire and disconnect hose assembly (17) from union (8).

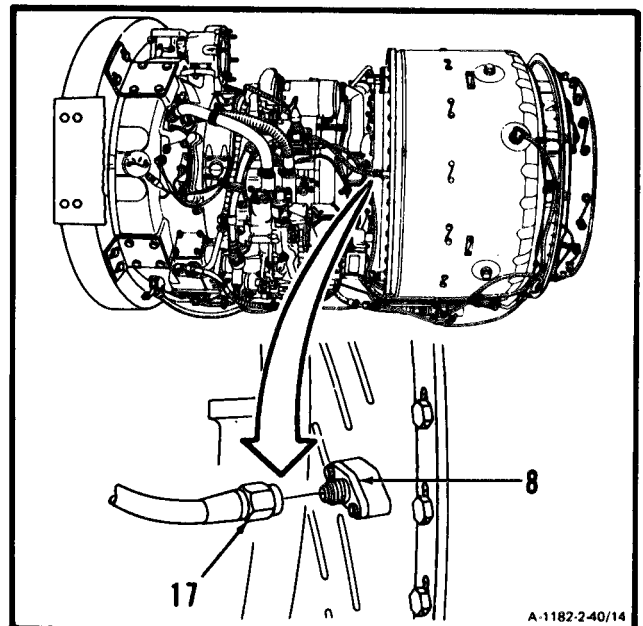
**GO TO NEXT PAGE**

2-40 REPAIR AIR DIFFUSER ASSEMBLY (Continued)

- b. Remove two bolts (5) and washers (5.1).
- c. Remove union (8) and seal ring (18).
- d. Install seal ring (18), serviceable union (8), two washers (5.1) and bolts (5).

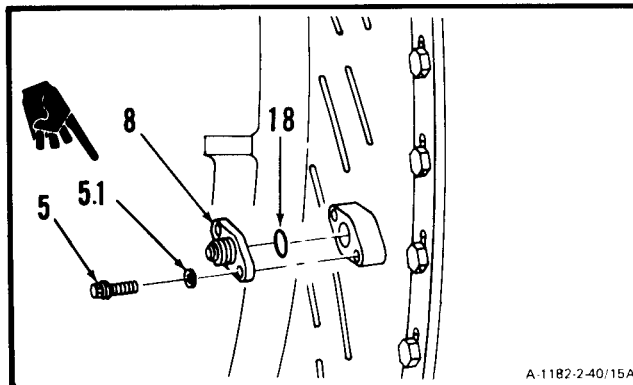

- e. Connect hose assembly (17) to union (8).
- f. Lockwire two bolts (5). Use lockwire (E29).

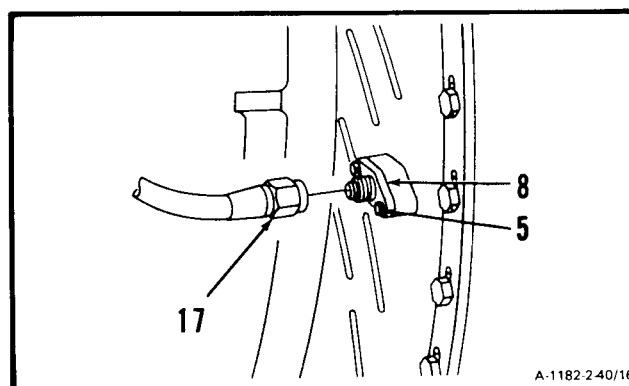

INSPECT

FOLLOW-ON MAINTENANCE:

None

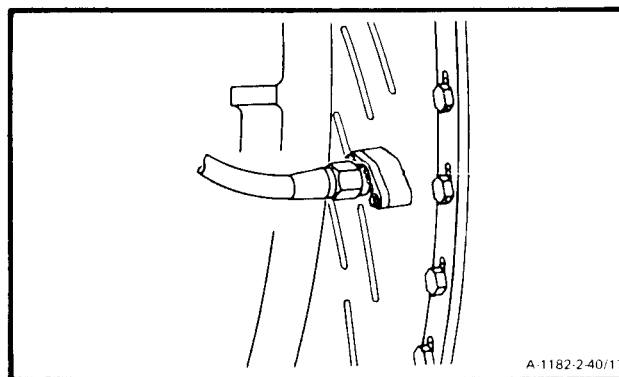

END OF TASK

2-41 INSTALL AIR DIFFUSER ASSEMBLY (AVIM)

2-41

INITIAL SETUP

Applicable Configurations:

All

Tools:

Powerplant Mechanic's Tool Kit,
NSN 5180-00-323-4944
Technical Inspection Tool Kit,
NSN 5180-00-323-5114
Alignment Pin (T2) (3) or
Guide Pin (Appendix E) (3)
Torque Wrench, 30-150 Inch-Pounds

Materials:

Lockwire (E29)

Parts:

Gaskets

Personnel Required:

68B10 Aircraft Powerplant Repairer
68B30 Aircraft Powerplant Inspector

References:

TM 55-2840-254-23P

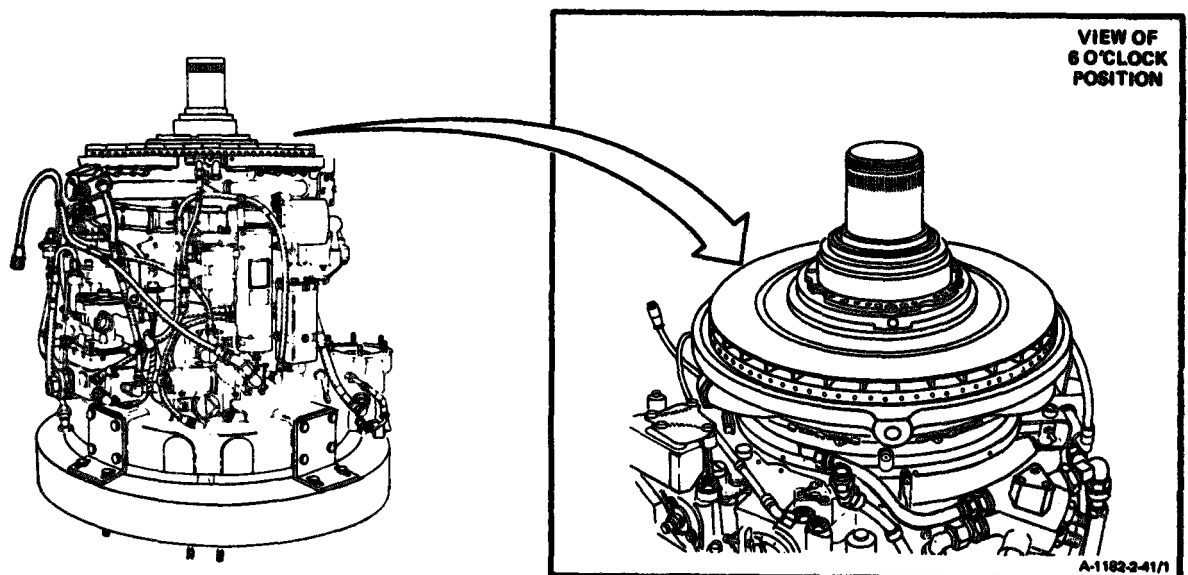

GO TO NEXT PAGE

1. Install alignment pin (T2) or guide pin (Appendix E) (1) in hole (2) located at the 6-o'clock position on the right of oil scavenge port (3).

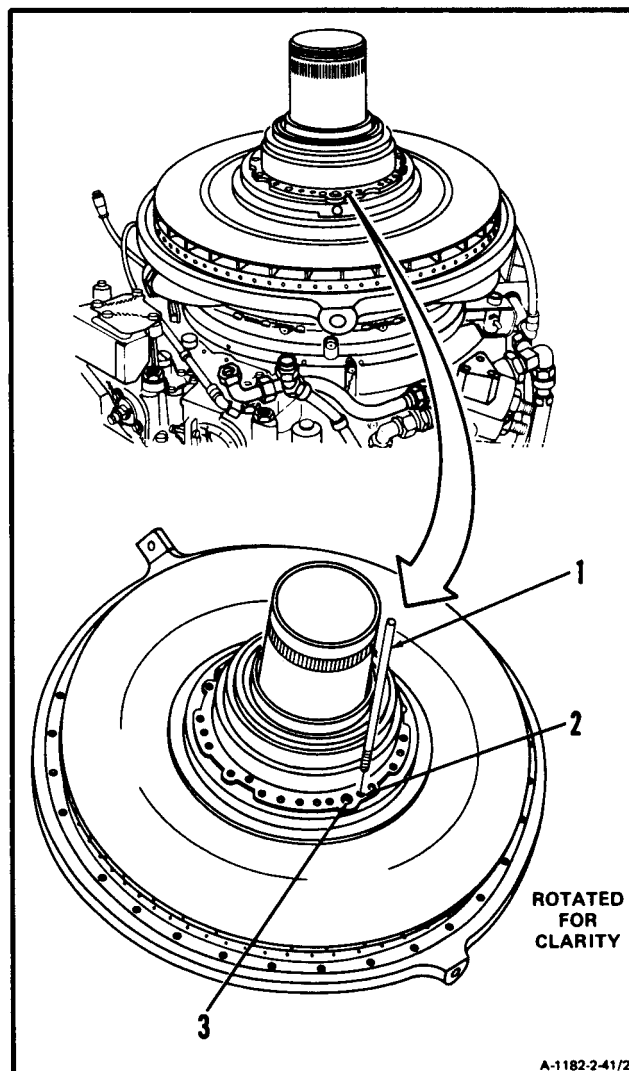

GO TO NEXT PAGE

2-41 INSTALL AIR DIFFUSER ASSEMBLY (AVIM) (Continued)

2-41

2. Install alignment pin (T2) or guide pin (Appendix E) (4) at 6-o'clock position on forward flange of air diffuser assembly (5).
3. Install alignment pin (T2) or guide pin (Appendix E) (6) at 12-o'clock position on forward flange of air diffuser assembly (5).

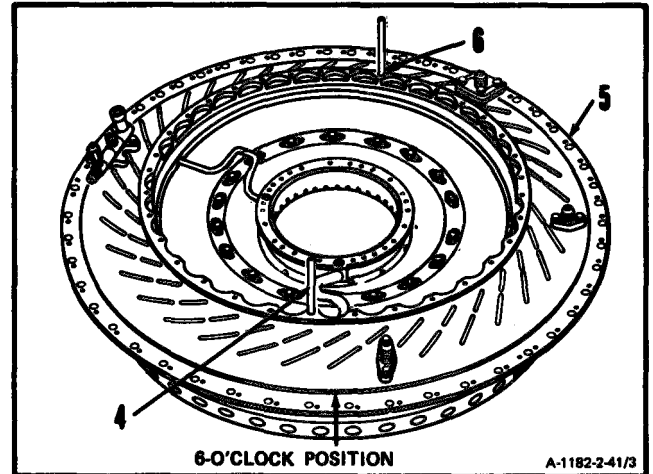

4. Install gaskets (7 and 8) on No. 2 bearing housing oil ports (9 and 10).

NOTE

Insure that all mounting holes in compressor spacer are properly aligned with the air diffuser assembly holes.

5. Align oil port (9) with oil port (11).

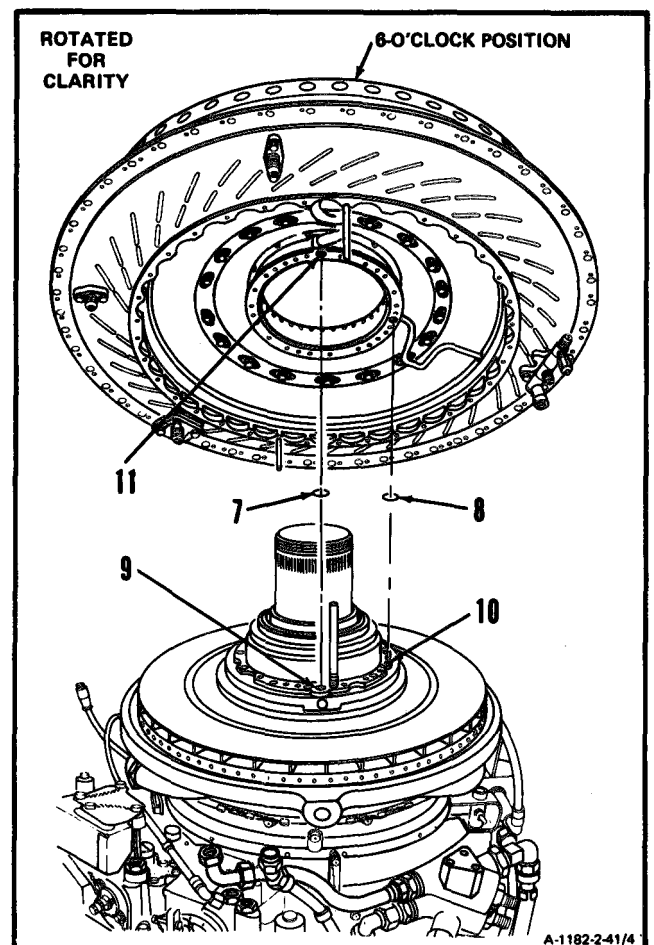
**GO TO NEXT PAGE**

6. Install air diffuser assembly (5) on compressor housing (12).

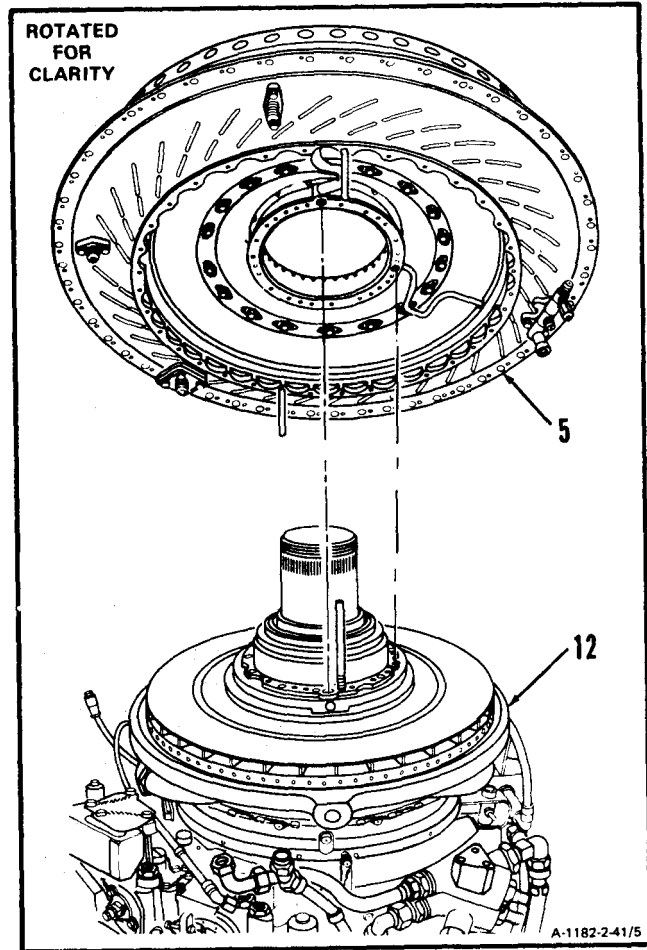

GO TO NEXT PAGE

2-41 INSTALL AIR DIFFUSER ASSEMBLY (AVIM) (Continued)

2-41

7. Install bracket (13), three washers (14) and bolts (15). Hand tighten bolts (15).

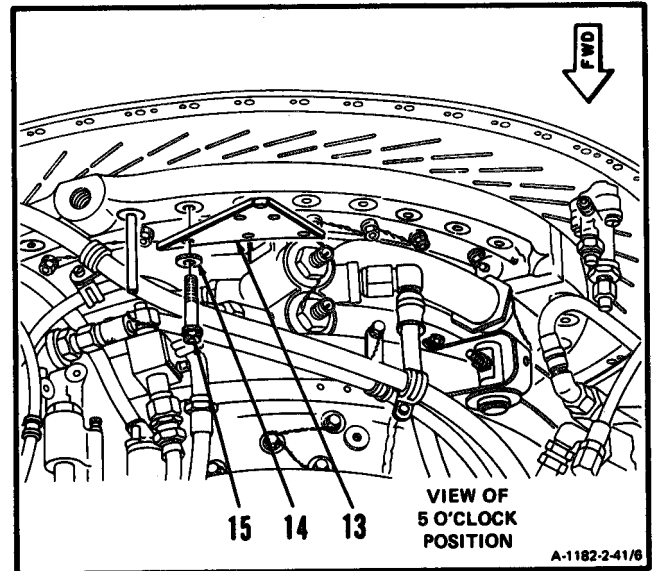

8. Install bracket (16), two washers (14) and two bolts (15). Hand tighten bolts (15).

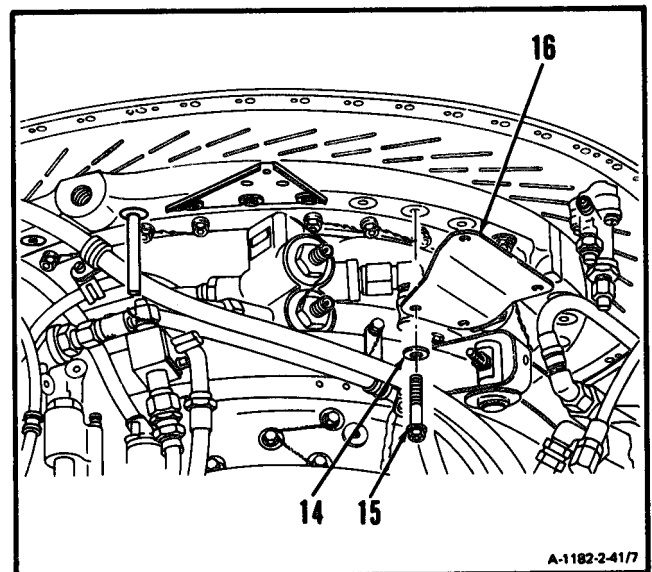

GO TO NEXT PAGE

9. Install bracket (17), washer (14) and bolt (15).
Hand tighten bolt (15).

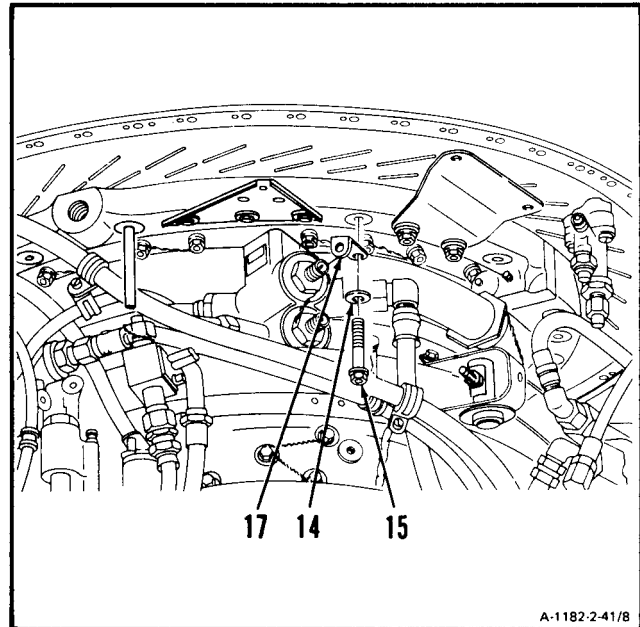

10. Remove alignment pin (T2) or guide pin (Appendix E) (4).

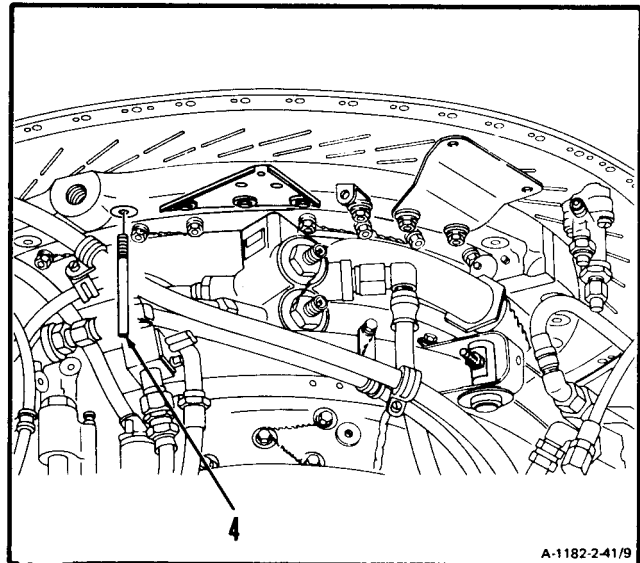

GO TO NEXT PAGE

2-41 INSTALL AIR DIFFUSER ASSEMBLY (AVIM) (Continued)

11. Remove alignment pin (T2) or guide pin (Appendix E) (6).

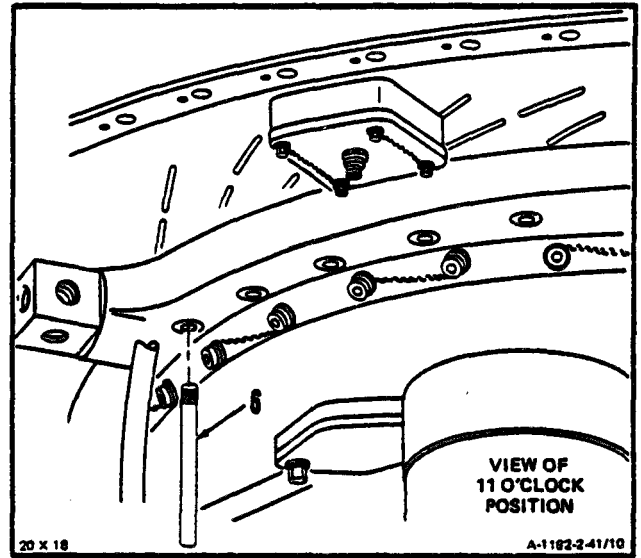

12. Install bracket (18) , washer (14), and bolt (15). Hand tighten bolt 15).

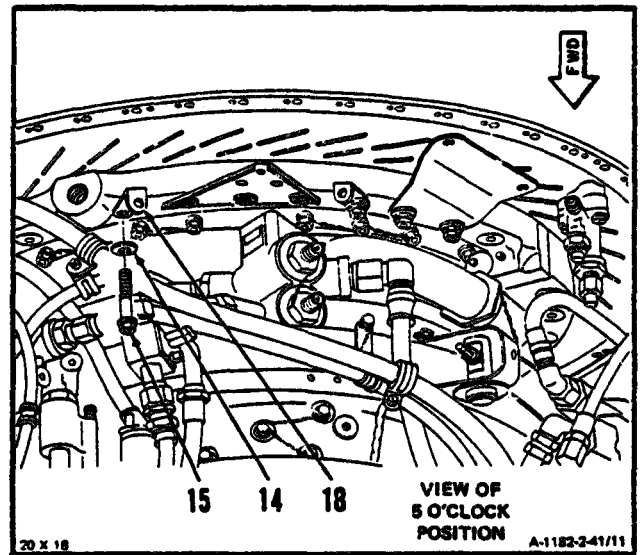

GO TO NEXT PAGE

- 13. Install remaining 25 washers (1) and bolts (15). Hand tighten bolts (15).
- 14. Torque 32 bolts (15) to 95 inch-pounds.
- 15. Lock-wire 32 bolts (15). Use lock-wire (E29).

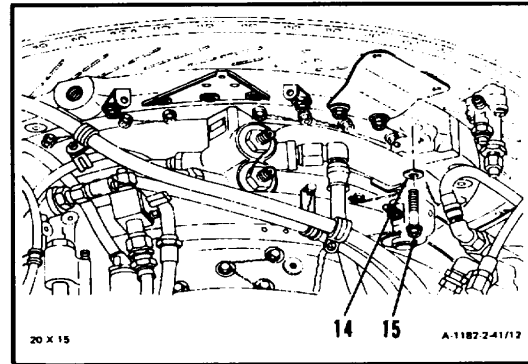

- 16. Install 3 bolts (19) into No. 2 bearing package. Torque bolts to 70 to 95 pound-inches. Bolts (19) do not require lock-wire.

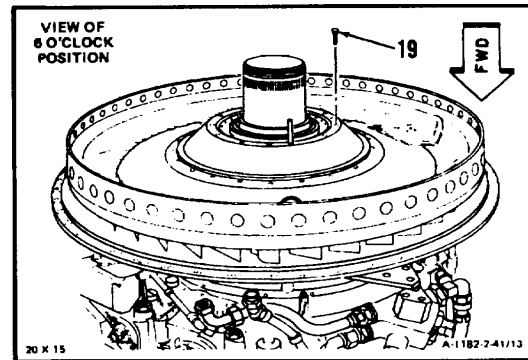

- 17. Remove alignment pin (T2) or guide pin (Appendix E) (1).

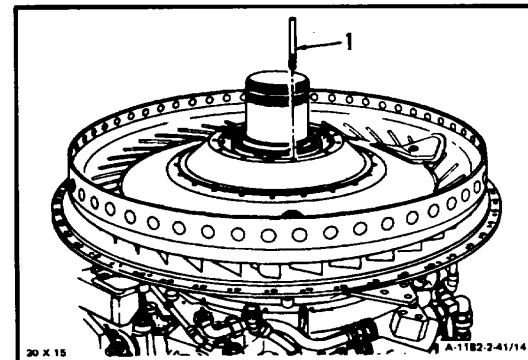

GO TO NEXT PAGE

2-41 INSTALL AIR DIFFUSER ASSEMBLY (AVIM) (Continued)

2-41

18. Slowly rotate compressor rotor shaft (20) by hand. Listen for any indications of rubbing or interference. If rubs are heard replace engine.

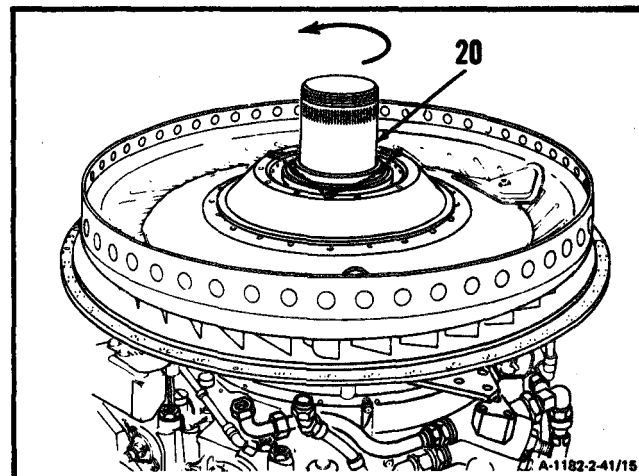

19. Connect hose assembly (21) to adapter (22).

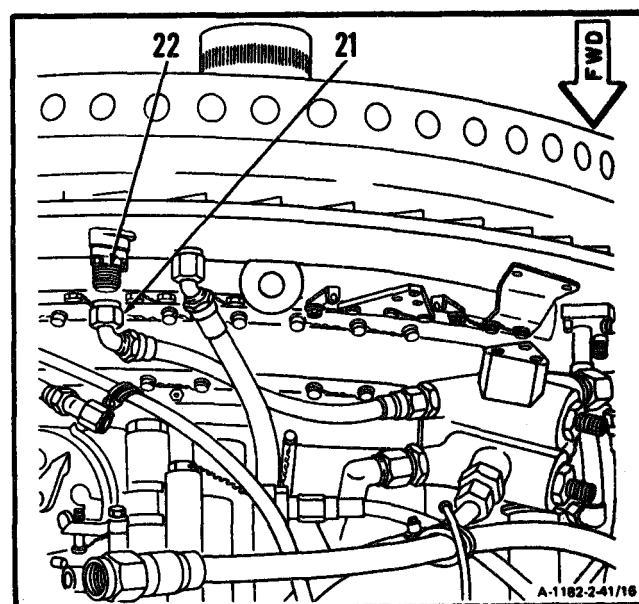

GO TO NEXT PAGE

20. Connect hose assembly (23) to pressure connector (24).

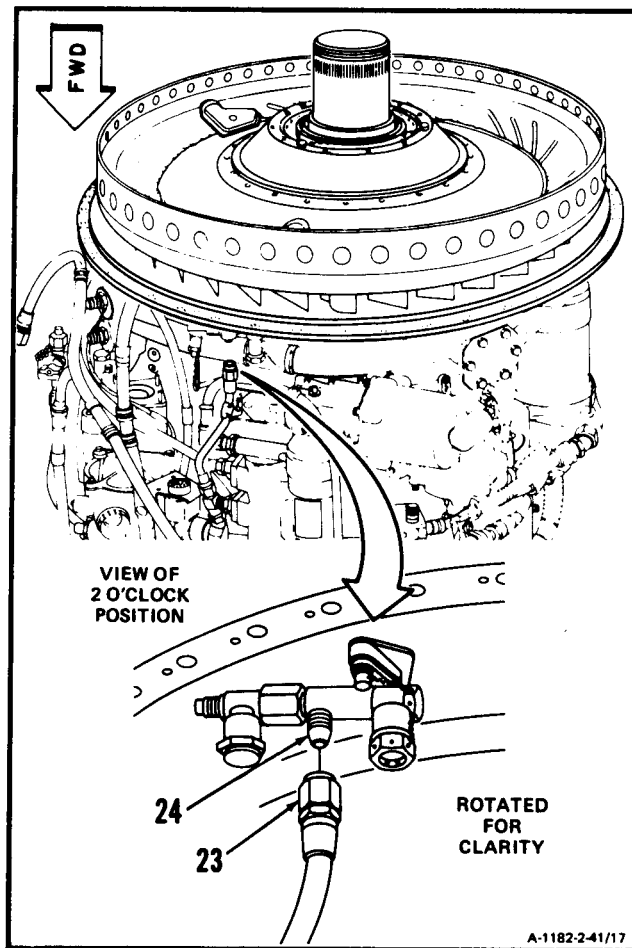

GO TO NEXT PAGE

2-41 INSTALL AIR DIFFUSER ASSEMBLY (AVIM) (Continued)

2-41

21. **Connect hose assembly (25) to union (26).**
22. Lockwire bolts (27). Use lockwire (E29).

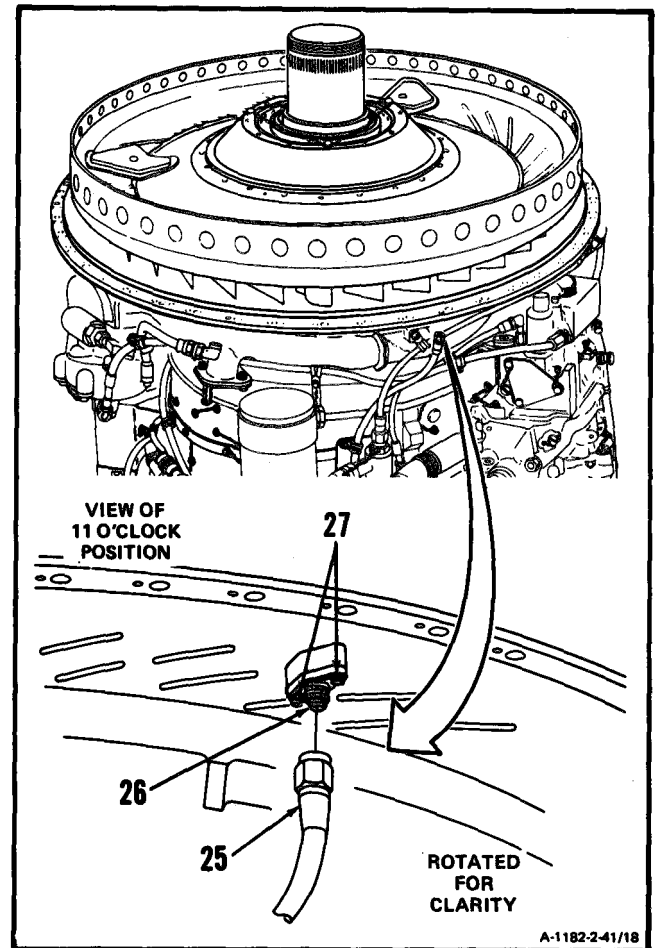

GO TO NEXT PAGE

2-41 INSTALL AIR DIFFUSER ASSEMBLY (AVIM) (Continued)

2-41

23. Connect hose assembly (28) to adapter (29).

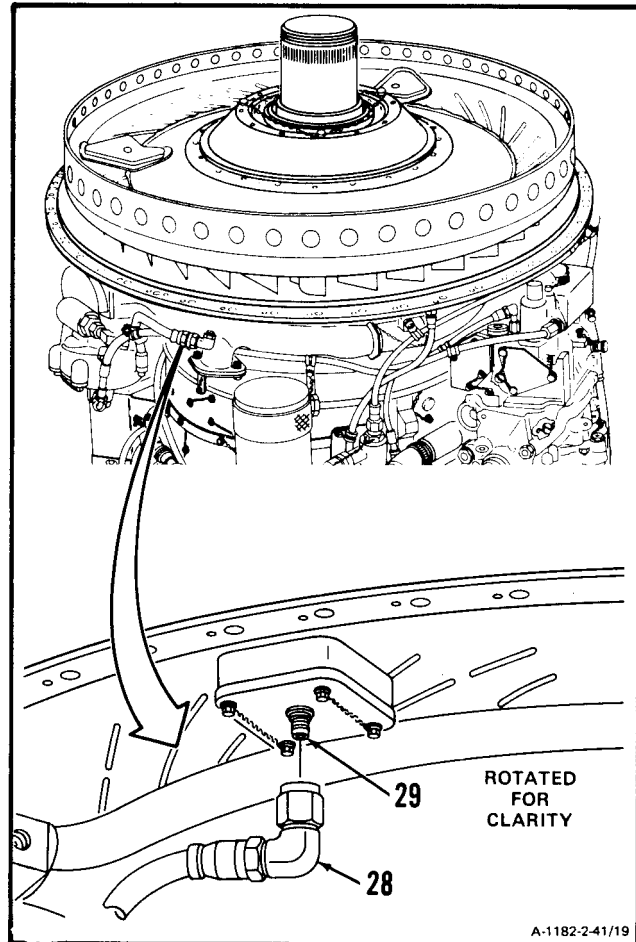

INSPECT

FOLLOW-ON MAINTENANCE:

- Install Diffuser Curl (Task 4-77).
- Install First Turbine Nozzle (Task 4-71).
- Install First Turbine Disc Assembly (Task 4-66).
- install Second Turbine Nozzle, Spacer and Case (Task 4-61).
- Install Second Turbine Disc Assembly (Task 4-56).
- Install Combustion Section and Power Turbine (Task 3-8).
- Service Engine Oil System Task 1 -74).

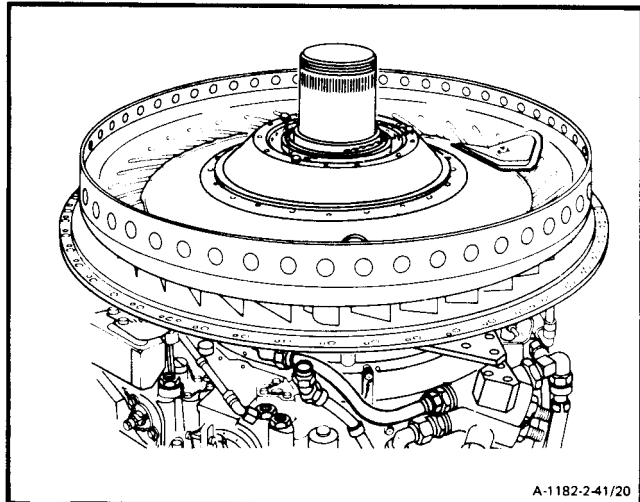

END OF TASK

Section VIII. NO. 2 BEARING PACKAGE - MAINTENANCE PROCEDURES

2-42 REMOVE NO. 2 BEARING PACKAGE (AVIM)

2-42

INITIAL SETUP

Applicable Configurations:

All

Tools:

Powerplant Mechanic's Tool Kit,
NSN 5180-00-323-4944
Mechanical Puller (T28)

Materials:

None

Personnel Required:

68B10 Aircraft Powerplant Repairer

Equipment Condition:

Engine Oil System Drained (Task 1-75)
Combustion Section and Power Turbine
Removed (Task 3-5)
Second Turbine Disc Assembly Removed
(Task 4-53)
Second Turbine Nozzle, Spacer and Case
Removed (Task 4-57)
First Turbine Disc Assembly Removed
(Task 4-62)
First Turbine Nozzle Assembly Removed
(Task 4-67)
Diffuser Curl Removed (Task 4-73)
Air Diffuser Assembly Removed (Task 2-36)

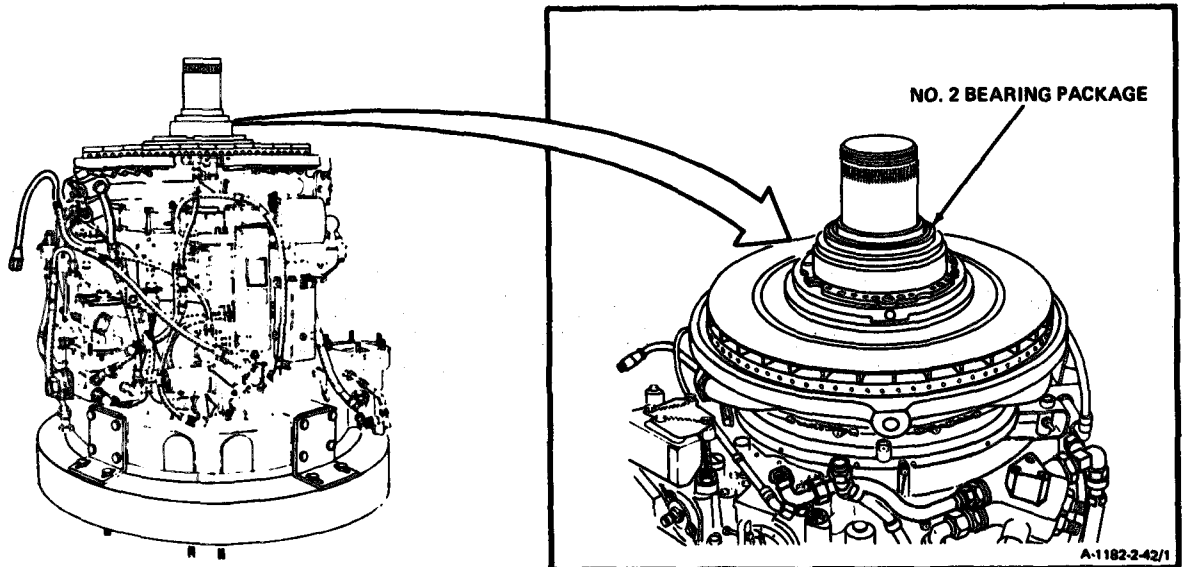

GO TO NEXT PAGE

1. **Disassemble mechanical puller (T28) (1)** as follows:

- a. Remove pins (2).
- b. Remove arm and pilot assembly (3).
- c. Separate two base halves (4).

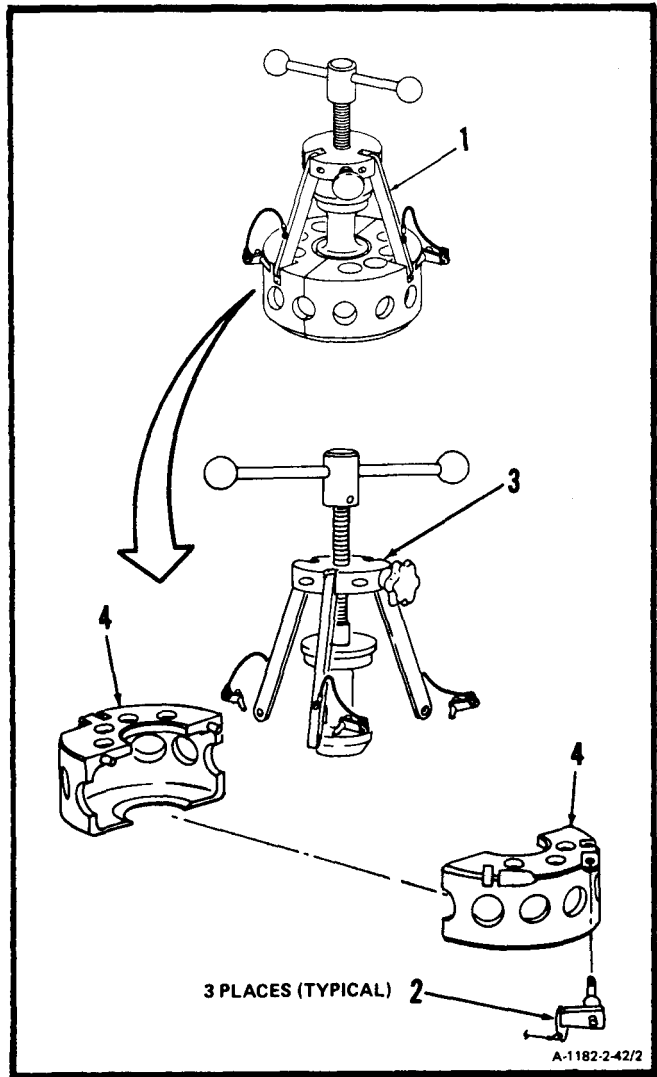

GO TO NEXT PAGE

2. Install mechanical puller (T28) as follows:

- a. Lift bearing housing (5) and install one half of base (4) on No. 2 bearing package (6).

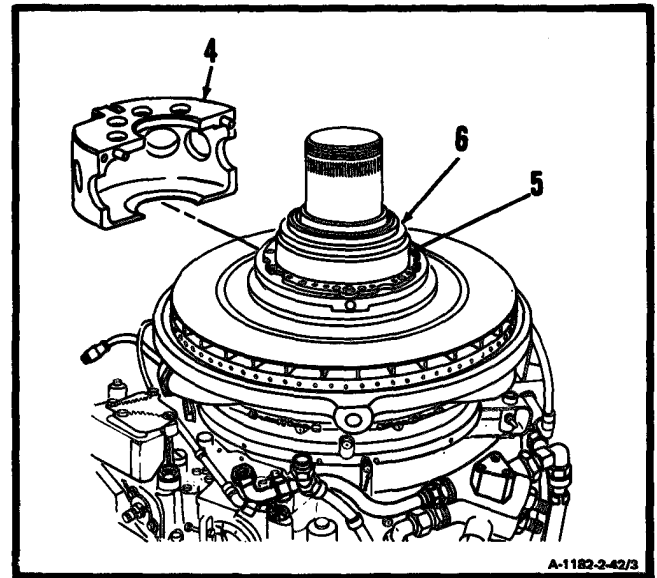

- b. Install second half of base (4) on No. 2 bearing package (6).

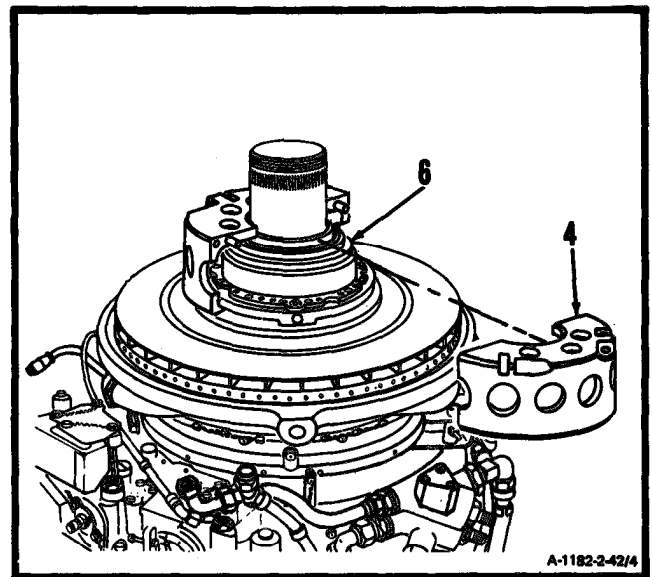

GO TO NEXT PAGE

- c. Install pilot assembly (3) in shaft (7).
- d. Install arms (8) in slots (9).

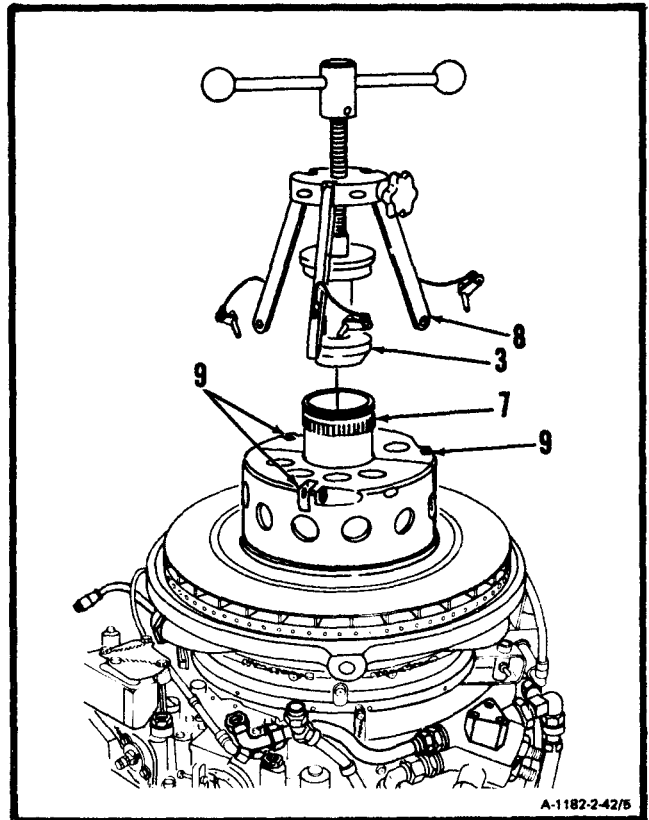

GO TO NEXT PAGE

e. Install pin (2) into hole (10).

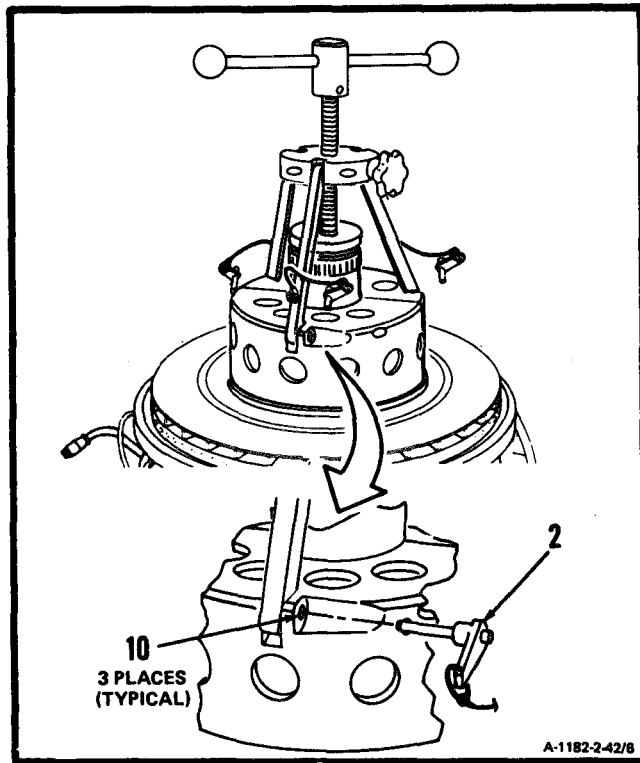

3. Hold knob (11) and turn handle (12) clockwise until No. 2 bearing package (6) is loose.

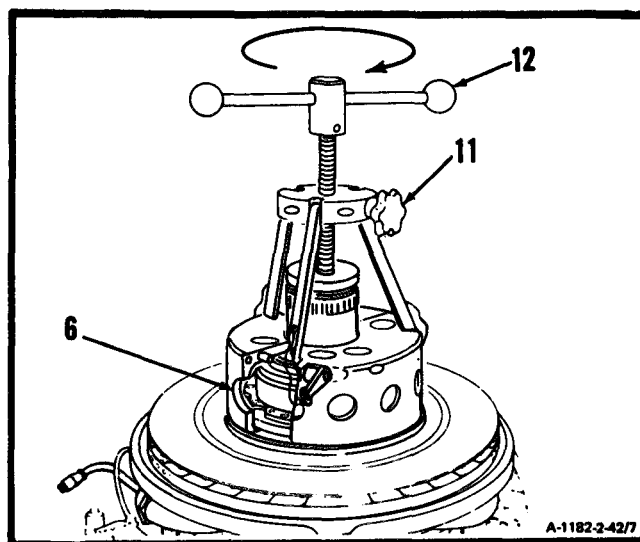

GO TO NEXT PAGE

4. Remove mechanical puller (T28) (1) with No. 2 bearing package (6) from shaft (7) and place on table.

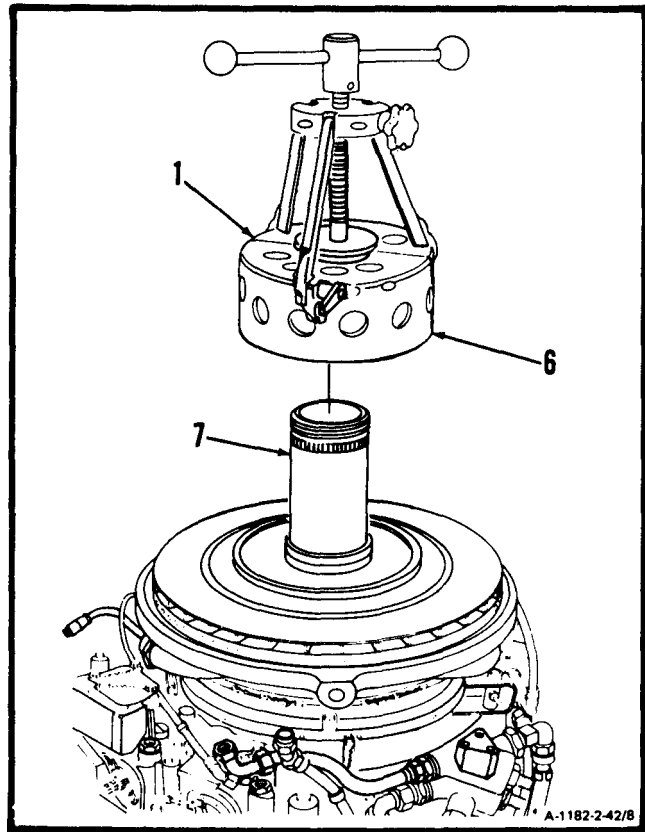

GO TO NEXT PAGE

2-42 REMOVE NO. 2 BEARING PACKAGE (AVIM) (Continued)

2-42

5. Remove pins (2), arm and pilot assembly (3), base (4) and **No. 2 bearing package (6).**

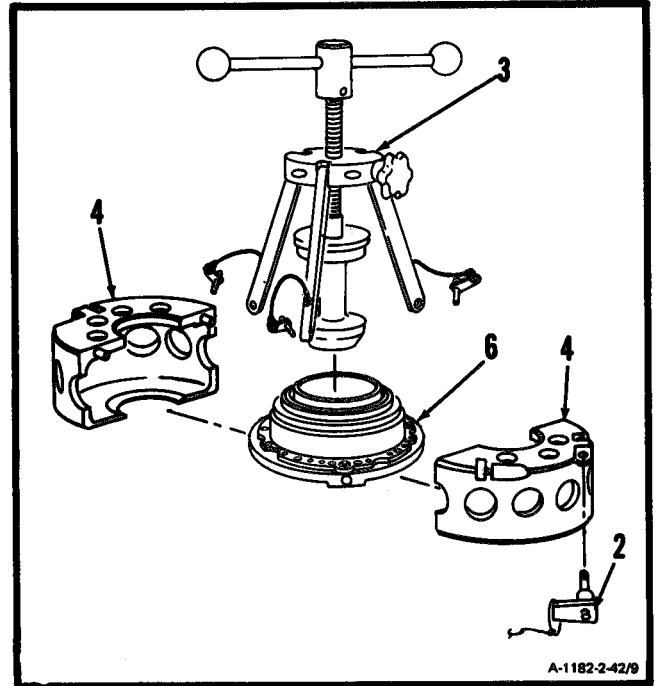

FOLLOW-ON MAINTENANCE:

None

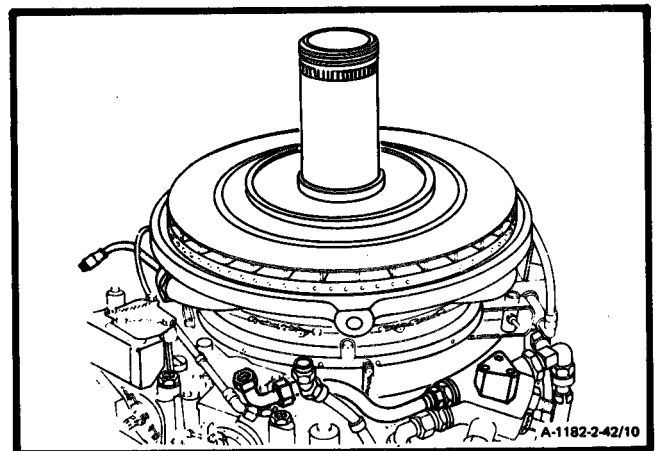

END OF TASK

INITIAL SETUP**Applicable Configurations:**

All

Tools:

Powerplant Mechanic's Tool Kit,
NSN 5180-00-323-4944
Handling Tools (T17)
Oil Seal Removal Tool (Appendix E)
Sleeve Bushing (Appendix E)
Arbor Press
Goggles

Materials:

Lint-Free Cloth (E26)

Personnel Required:

68B10 Aircraft Powerplant Repairer

Equipment Condition:

Engine Oil System Drained (Task 1-75)
Combustion Section and Power Turbine
Removed (Task 3-5)
Second Turbine Disc Assembly Removed
(Task 4-53)
Second Turbine Nozzle, Spacer and Case
Removed (Task 4-57)
First Turbine Disc Assembly Removed
(Task 4-62)
First Turbine Nozzle Assembly Removed
(Task 4-67)
Diffuser Curl Removed (Task 4-73)
Air Diffuser Assembly Removed (Task 2-36)
No. 2 Bearing Package Removed (Task 2-42)

1. Remove bearing housing liner (1) from retainer assembly (2).

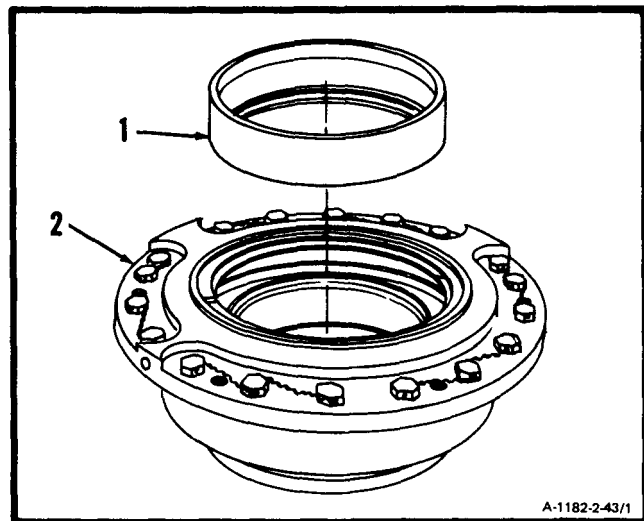

A-1182-2-43/1

GO TO NEXT PAGE

WARNING

Be careful when removing retaining ring. Spring tension could cause screwdriver to dip and cause injury. If injury occurs, get medical attention.

2. Wear goggles. Pry slot of retaining ring (3) out from under lip (4) of retainer assembly (2). Use screwdriver (5).
3. Remove retaining ring (6) from retainer assembly (2).

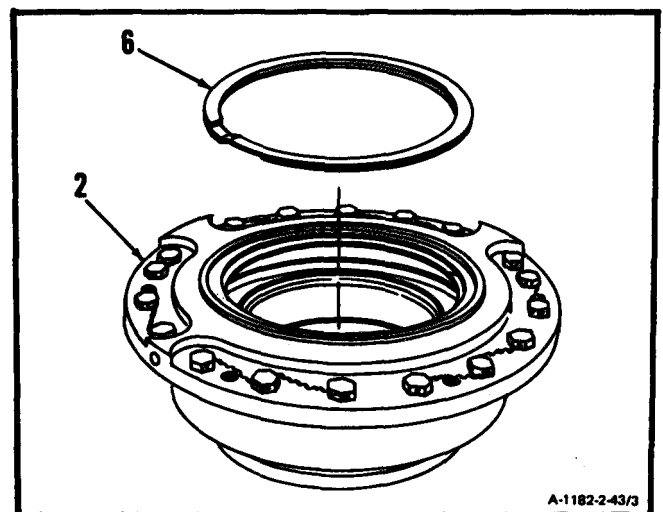
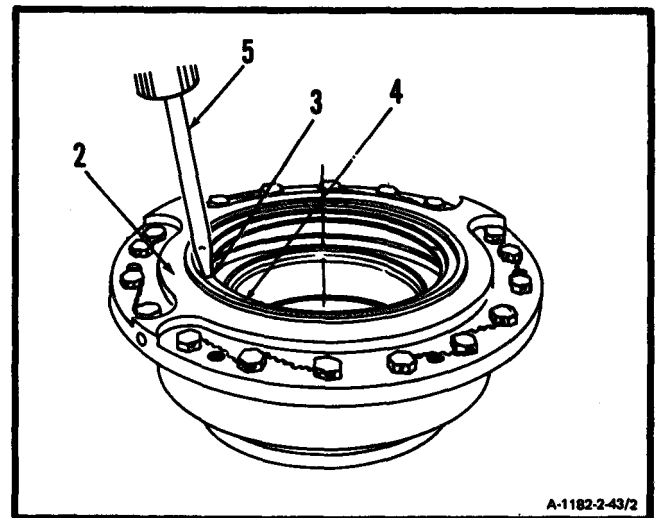

GO TO NEXT PAGE

4. Remove lockwire and 18 bolts (7).

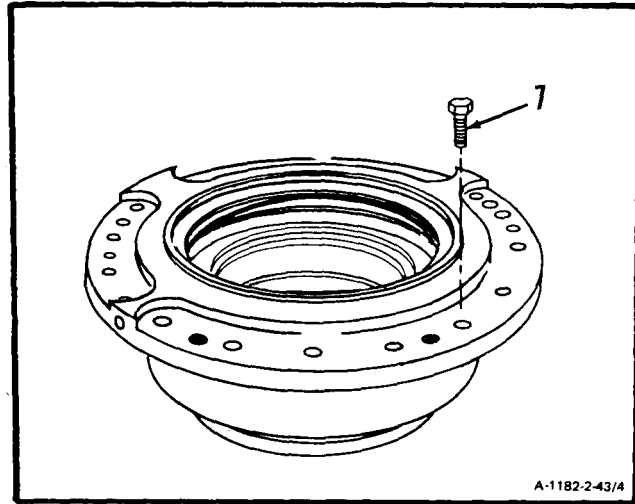

5. Turn retainer assembly (2) over and install three handling tools (T17) (8) into three holes (9) in housing (10).

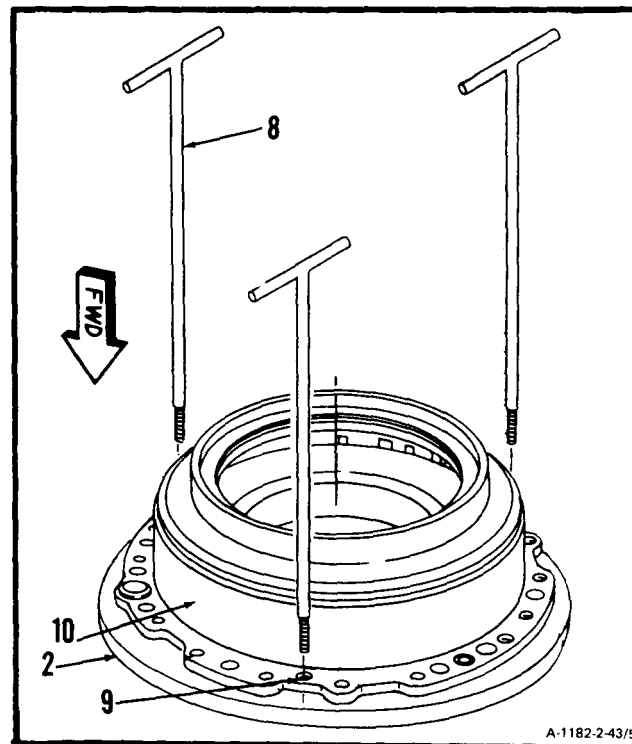

GO TO NEXT PAGE

6. Remove retainer assembly (2) from housing (10) using three handling tools (T17) (8).
7. Remove three handling tools (T17) (8) from housing (10).

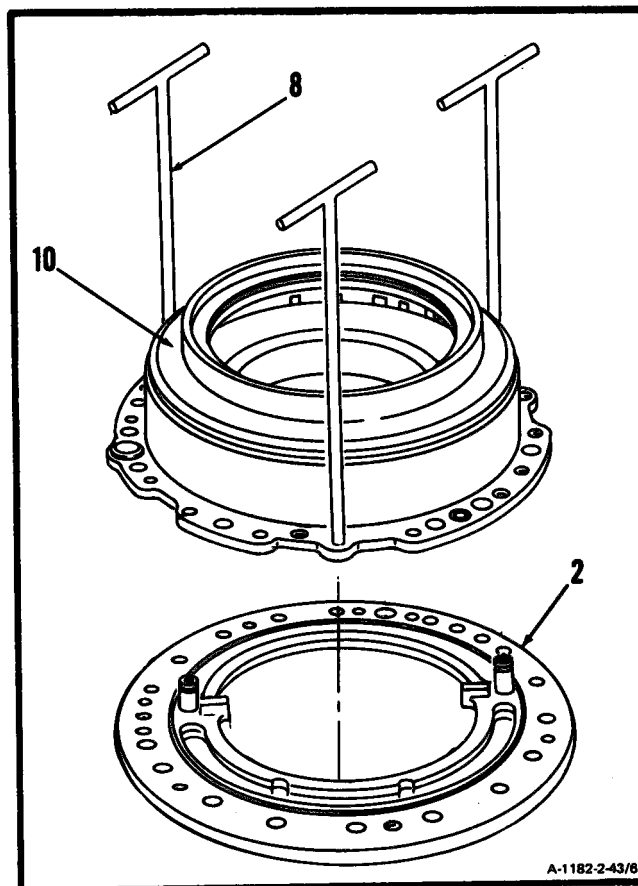

GO TO NEXT PAGE

8. Remove gaskets (11, 12, and 13) and packings (14) from retainer assembly (2).

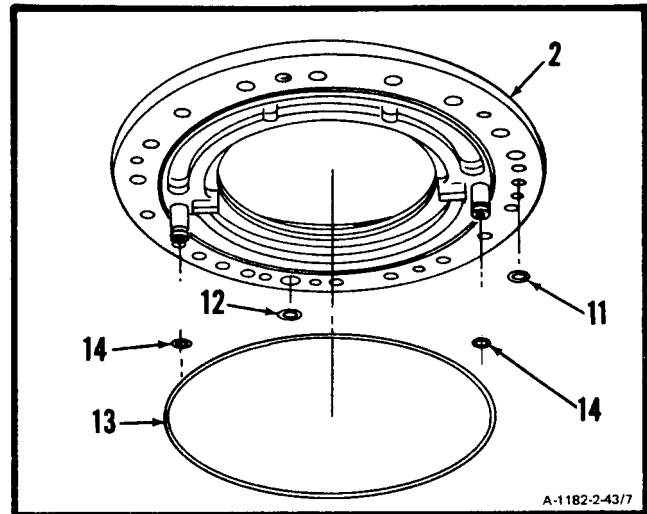

9. Place retainer assembly (2) on sleeve bushing (Appendix E) (15). **Remove seal (16)** from retainer assembly (2). Use oil seal removal tool (Appendix E) (17) and arbor press.

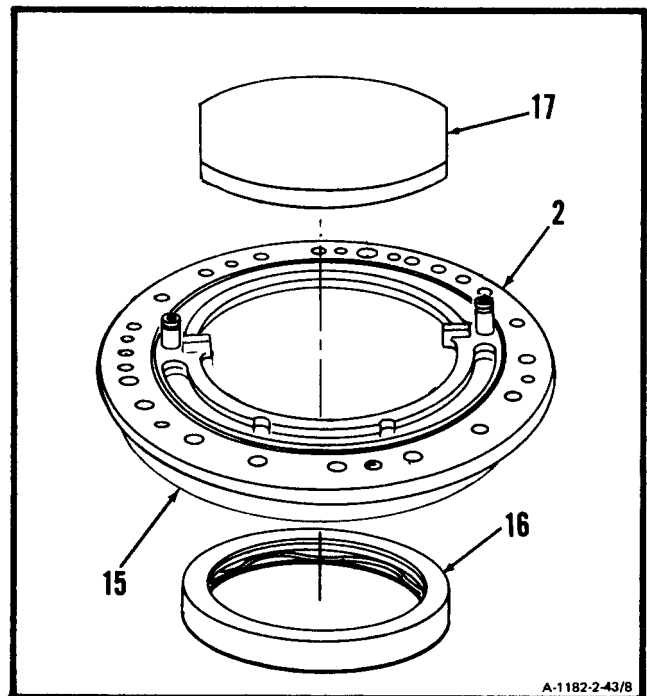

GO TO NEXT PAGE

10. Remove lockwire and eight bolts (18).

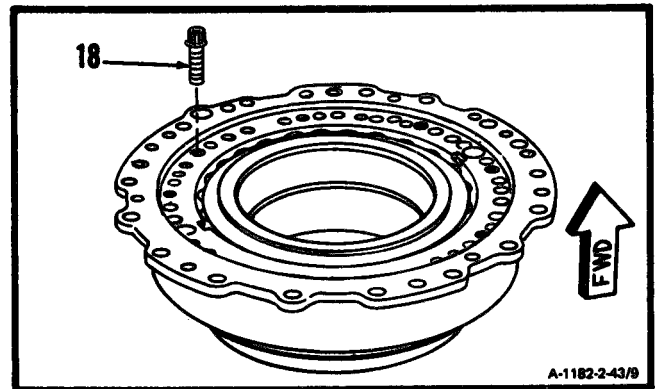

11. Remove bearing retaining ring (19) and shim (20) from housing (10).

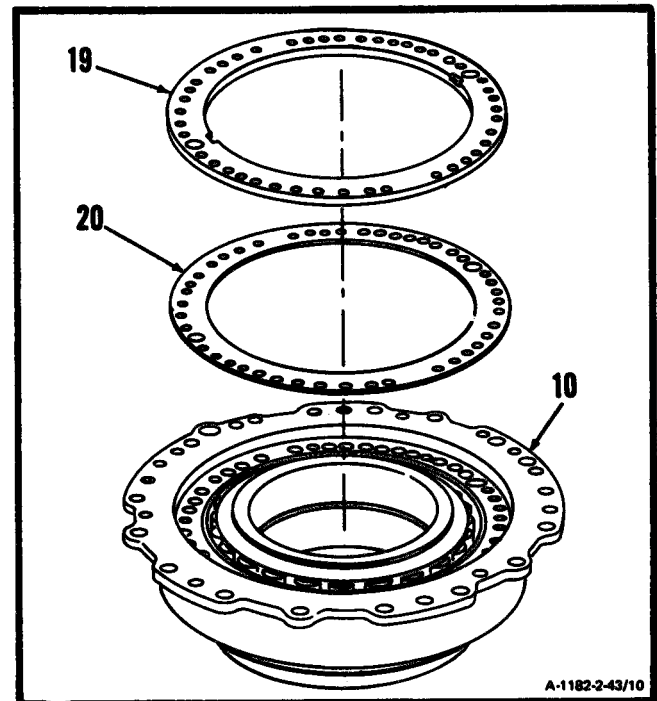

GO TO NEXT PAGE

CAUTION

Protect bearings from damage. Handle only in clean area, Use clean, lint-free cloth (E26). Damaged bearings can cause engine failure.

12. Remove No. 2 bearing inner race (21) from housing (10).

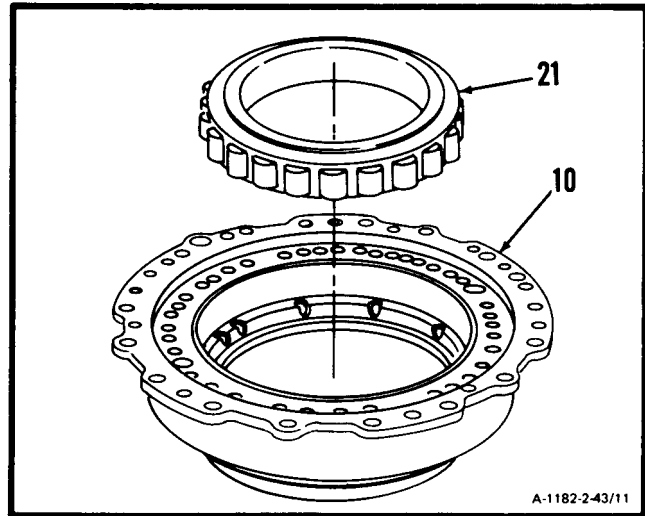

13. Remove No. 2 bearing outer race (22) from housing (10).

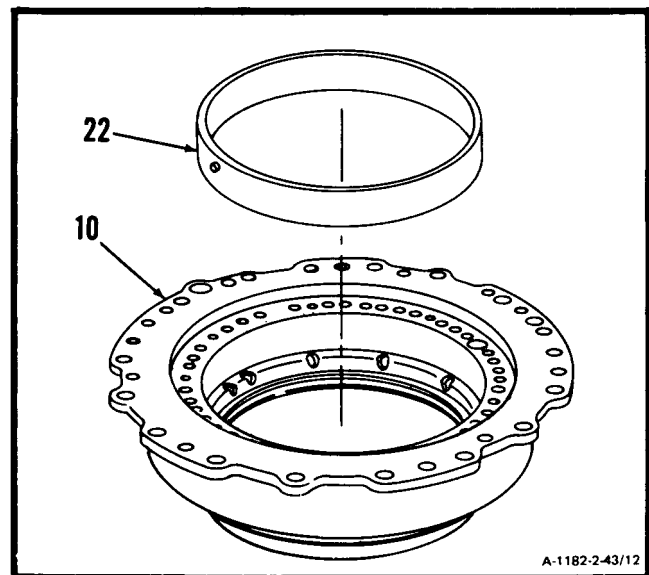

GO TO NEXT PAGE

14. Remove bearing housing liner (23) from housing (10).

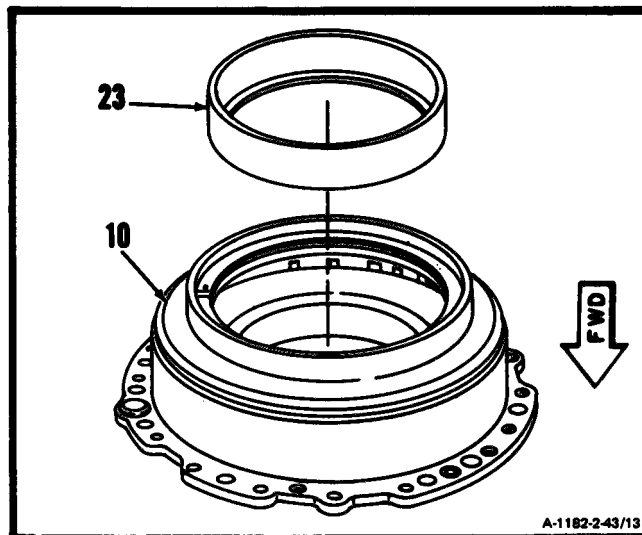

WARNING

Be careful when removing retaining ring. Spring tension could cause screwdriver to slip and cause injury. If injury occurs, get medical attention.

15. Wear goggles. Pry slot of retaining ring (24) out from under lip (25) of housing (10). Use screwdriver (5).

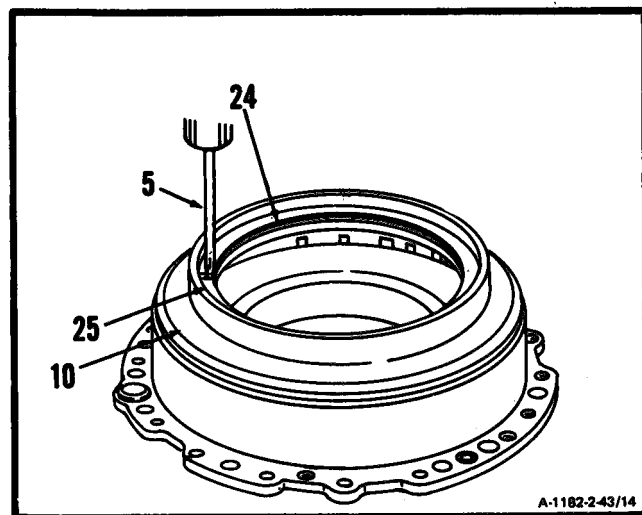

GO TO NEXT PAGE

16. Remove retaining ring (24) from housing (10).

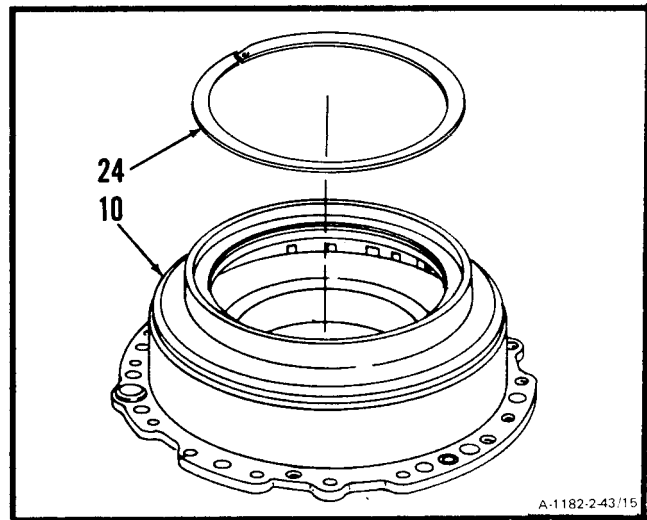

17. Place housing (10) on sleeve bushing (Appendix E) (15). **Remove seal (26)** from housing (10). Use oil seal removal tool (Appendix E) (17) and arbor press.

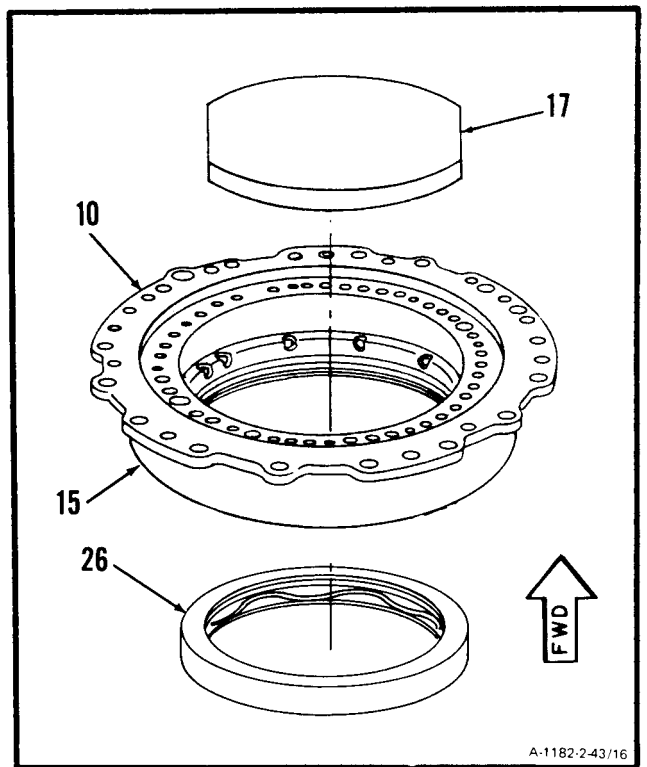

FOLLOW-ON MAINTENANCE:

None

END OF TASK

2-44 CLEAN NO. 2 BEARING PACKAGE (AVIM)

2-44

INITIAL SETUP**Applicable Configurations:**

All

Tools:

Compressed Air Source
 Fiber Brush
 Goggles

Materials:

Dry Cleaning Solvent (E17)
 Gloves (E20)
 Lint-Free Cloth (E26)
 Lubricating Oil (E32 or E33)

Personnel Required:

68B10 Aircraft Powerplant Repairer

Equipment Condition:

Off Engine Task
 Engine Oil System Drained (Task 1-75)
 Combustion Section and Power Turbine
 Removed (Task 3-5)
 Second Turbine Disc Assembly Removed
 (Task 4-53)

Second Turbine Nozzle, Spacer and Case
 Removed (Task 4-57)

First Turbine Disc Assembly Removed
 (Task 4-62)

First Turbine Nozzle Assembly Removed
 (Task 4-67)

Diffuser Curl Removed (Task 4-73)

Air Diffuser Assembly Removed (Task 2-36)

No. 2 Bearing Package Removed (Task 2-42)

No. 2 Bearing Package Disassembled
 (Task 2-43)

General Safety Instructions:**WARNING**

Dry cleaning solvent (E17) is flammable and toxic. It can irritate skin and cause burns. Use only in well-ventilated area, away from heat and open flame. In case of contact, immediately flush skin or eyes with water for at least 15 minutes. Get medical attention for eyes.

GO TO NEXT PAGE

1. Clean No. 2 bearing package as follows:

CAUTION

Protect bearings from damage. Handle only in clean area. Use clean, lint-free cloth (E26). Damaged bearings can cause engine failure.

- a. Wear gloves (E20). Immerse two liners (1), two retaining rings (2), two seals (3), re-retain assembly (4), retaining ring (5), shim (6), bearing (7), and housing assembly (8) in dry cleaning solvent (E17).
- b. Remove contaminants from parts other than carbon seals by scrubbing with fiber brush.

WARNING

When using compressed air for cleaning, use approved protective equipment for eyes and face. Do not use more than 30 psig air pressure. Do not direct air toward yourself or another person. Failure to comply could result in injury to eyes or skin. In case of injury, get medical attention.

- c. Wear goggles. Blow dry parts using clean, dry compressed air.

WARNING

Lubricating oils (E32 and E33) cause paralysis if swallowed. Prolonged contact with them may irritate the skin. Handle only in well-ventilated areas away from heat and flame. Drain and store in approved metal safety containers. Avoid prolonged or repeated contact with skin and do not take internally. Wash contacted areas of skin thoroughly after handling. If irritation of skin results, get medical attention. Get medical attention for eyes.

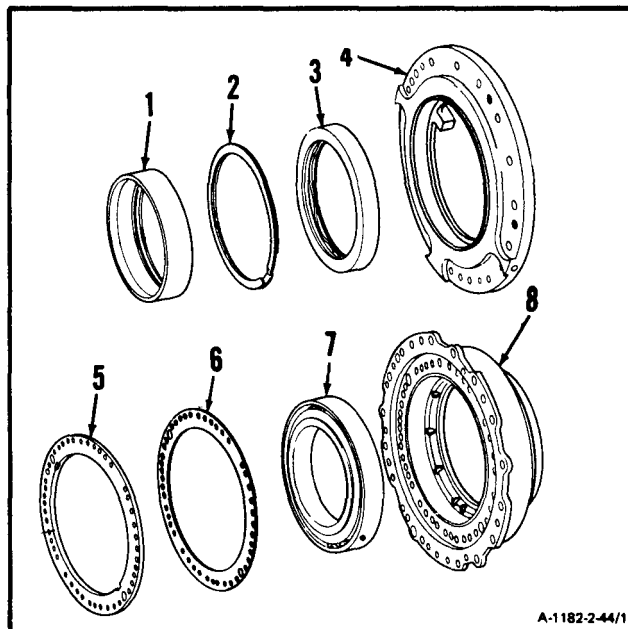

GO TO NEXT PAGE

2-44 CLEAN NO. 2 BEARING PACKAGE (AVIM) (Continued)

2-44

2. Dip bearing (7) in lubricating oil (E32 or E33).

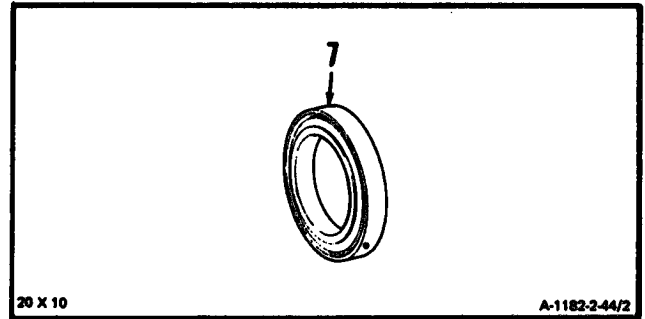
**FOLLOW-ON MAINTENANCE:**

Impact No. 2 Bearing Package (Task 245).

END OF TASK

INITIAL SETUP

Applicable Configuration:

All

Tools:

Technical Inspection Tool Kit,
 NSN 5180-00-323-5114
 Goggles
 Compressed Air Source

Materials:

None

Personnel Required:

68B30 Aircraft Powerplant Inspector

Equipment Condition:

Off Engine Task

1. Inspect two bearing housing liners (1).

- a. There shall be no corrosion or pitting.
- b. There shall be no cracks.
- c. There shall be no scoring or wear on any area of the liner outside circumference (2).

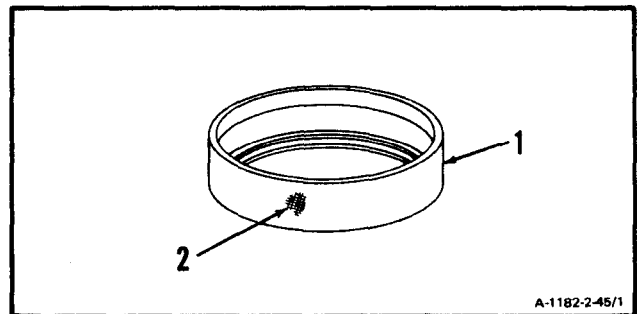

2. Inspect two retaining rings (3). There shall be no cracks or bends.

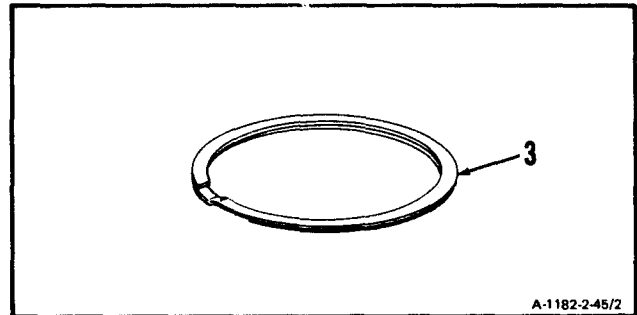

GO TO NEXT PAGE

3. Inspect two seals (4), as follows:

- a. There shall be no cracks, nicks or scratches on housing (5).
- b. There shall be no corrosion on housing (5).

NOTE

In following step do not mistake segment for cracks.

- c. There shall be no springs (6) or carbon elements (7) cracked or broken out of housing (5).
- d. There shall be no chipping on seal carbon elements (7).

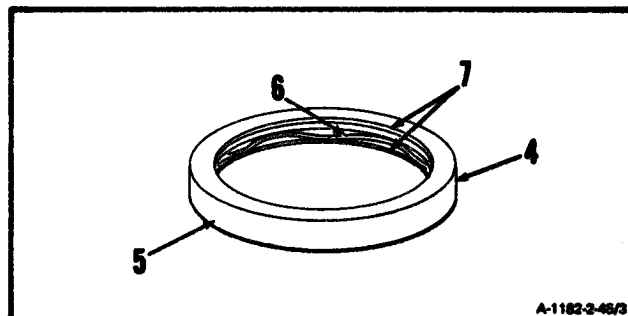
**4. Inspect bearing (8).**

- a. There shall be no rust or broken parts.
- b. There shall be no pits or dents deeper than 0.002 inch on rolling surfaces (9).
- c. There shall be no foreign matter clogging the bearing which would prevent free rotation.
- d. There shall be no purple, red-purple, or blue discoloration.

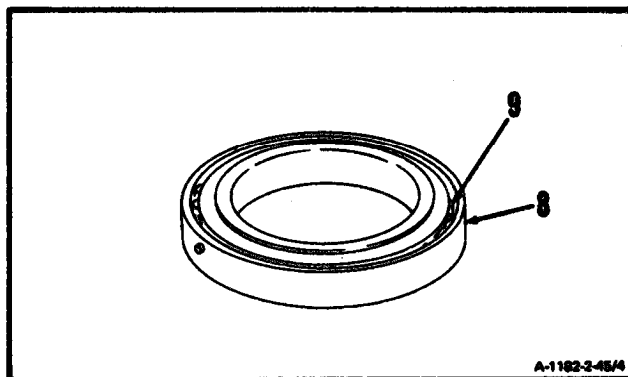

GO TO NEXT PAGE

5. Inspect retainer assembly (10), bearing retaining ring (11), shim (12), and housing assembly (13). There shall be no cracks.

WARNING

When using compressed air for cleaning, use approved protective equipment for eyes and face. Do not use more than 30 psig air pressure. Do not direct air toward yourself or another person. Failure to comply could result in injury to eyes or skin. In case of injury, get medical attention.

6. Inspect oil jet couplings (17) and passages (15 and 16). There shall be no blockage. Wear goggles and apply compressed air to jet couplings (17). Use clean, dry compressed air. Feel for air flow at passage holes (15 and 16).

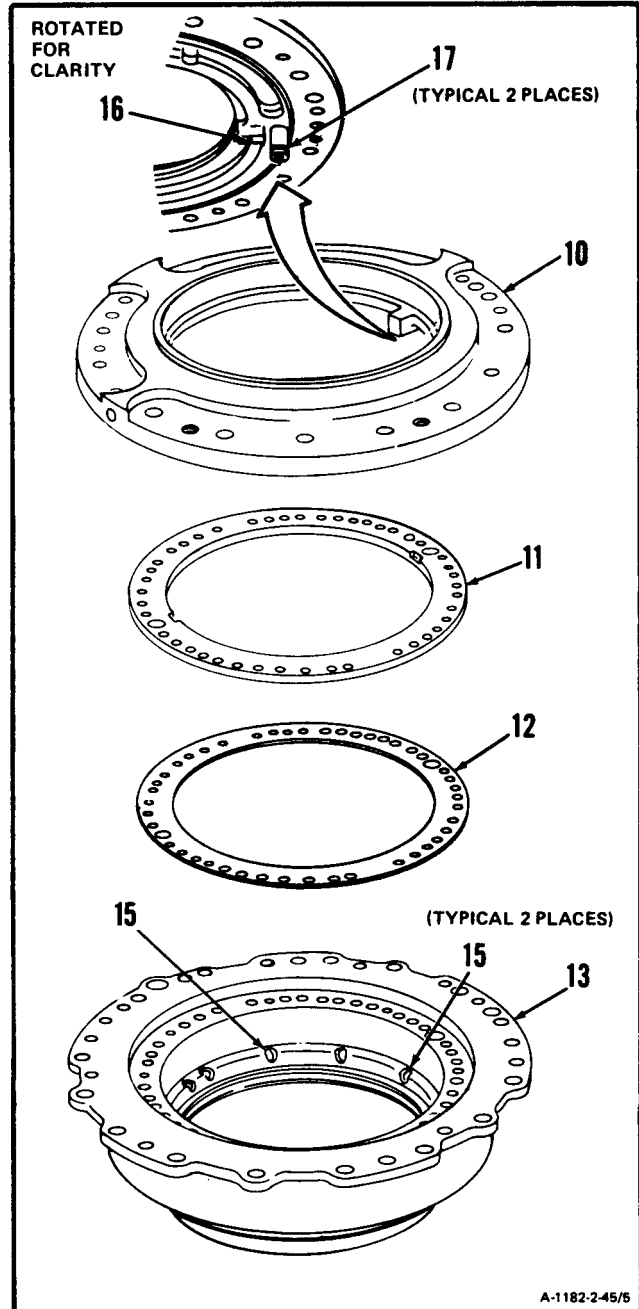

FOLLOW-ON MAINTENANCE:

None

END OF TASK

2-46 ASSEMBLE NO. 2 BEARING PACKAGE (AVIM)

2-46

INITIAL SETUP**Applicable Configurations:**

All

Tools:

Powerplant Mechanic's Tool Kit,
NSN 5180-00-3234944
Technical Inspection Tool Kit,
NSN 5180-00-323-5114
Oil Seal Installation Tool (Appendix E)
Outside Micrometer Caliper Set
Micrometer Depth Gage
Arbor Press
Sleeve Bushing (Appendix E)
Torque Wrench, 30-150 Inch-Pounds

Materials:

Lockwire (E29)
Lubricating Oil (E32)
Lubricating Oil (E33)
Shortening Compound (E46)

Parts:

Packings
Gaskets
Shims

Personnel Required:

68B10 Aircraft Powerplant Repairer
68B30 Aircraft Powerplant Inspector

References:

TM 55-2840-254-23P

Equipment Condition:

Off Engine Task

General Safety Instructions:**WARNING**

Lubricating oils (E32 and E33) cause paralysis if swallowed. Prolonged contact with them may irritate the skin. Handle only in well-ventilated areas away from heat and flame. Drain and store in approved metal safety containers. Avoid prolonged or repeated contact with skin and do not take internally. Wash contacted areas of skin thoroughly after handling. If irritation of skin results, get medical attention. Get medical attention for eyes.

GO TO NEXT PAGE

CAUTION

Seal must be dipped in lubricating oil before installation. Failure to comply will cause damage to seal during dry running period of initial engine starts.

NOTE

If part number is not visible, retaining ring that holds carbon seal elements should face out.

1. Dip serviceable seal (1) in lubricating oil (E32 or E33), **Press seal (1) in housing (2)** with part number facing down. Use oil seal installation tool (Appendix E) (3) and arbor press.

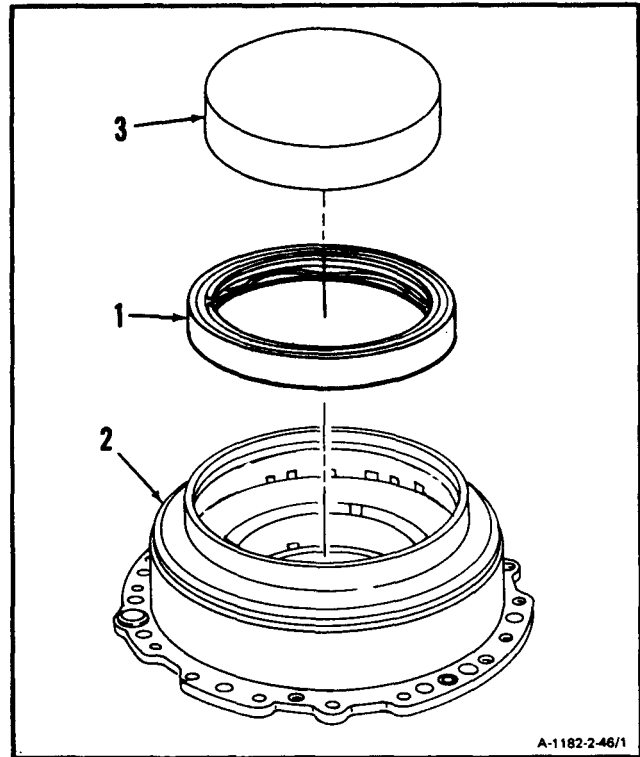

2. Install retaining ring (4) in housing (2).

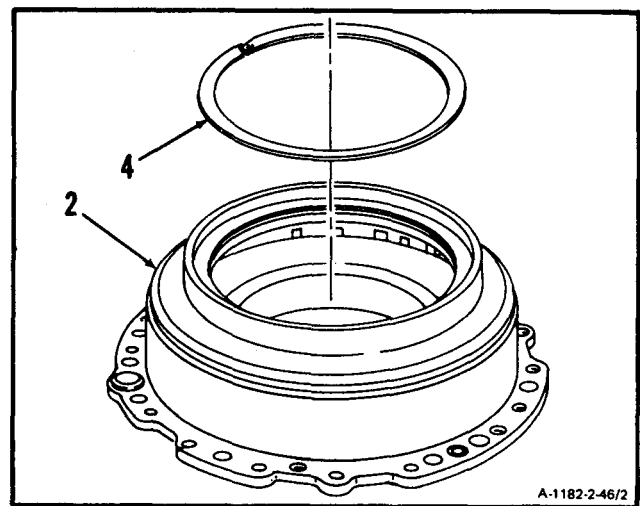
**INSPECT****GO TO NEXT PAGE**

3. Install bearing housing liner (5) in housing (2).

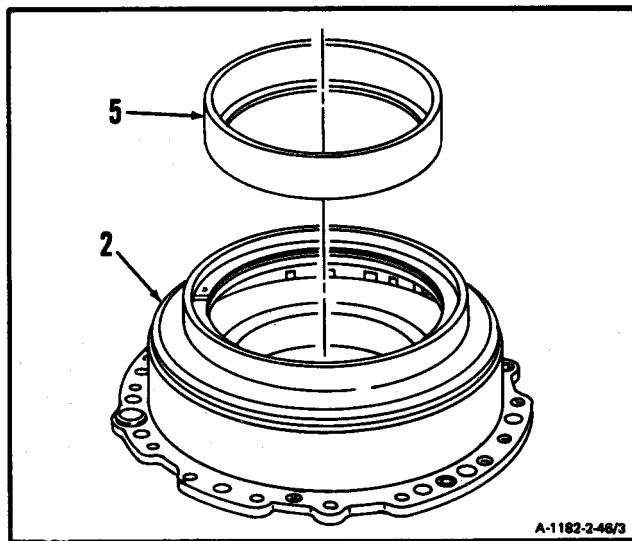

4. Determine required thickness of shim (6) as follows:

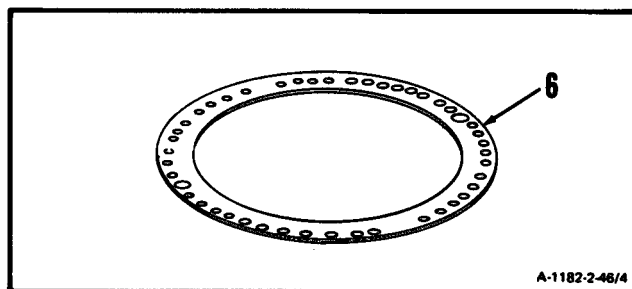

GO TO NEXT PAGE

- a. On housing assembly (7), measure from forward surface (8) to rear surface (9). Record as Dimension A.

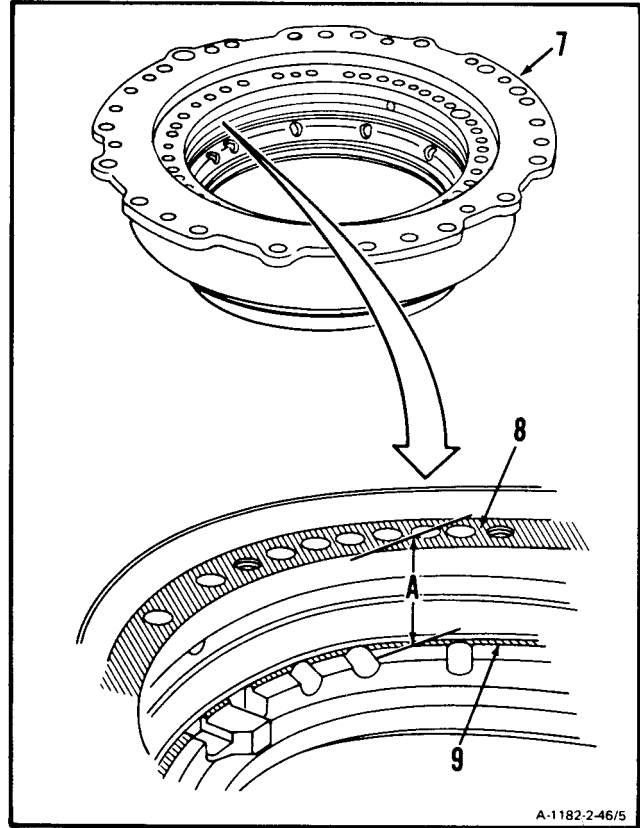

A-1182-2-46/5

- b. On bearing outer race (10), measure from forward edge (11) to rear edge (12). Record as Dimension B.

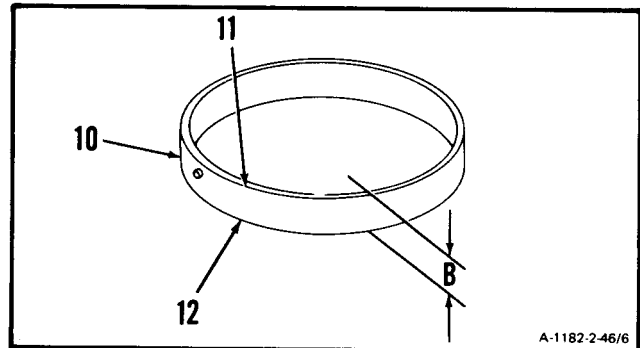

A-1182-2-46/6

- c. Subtract Dimension A from Dimension B. Record as Dimension C.

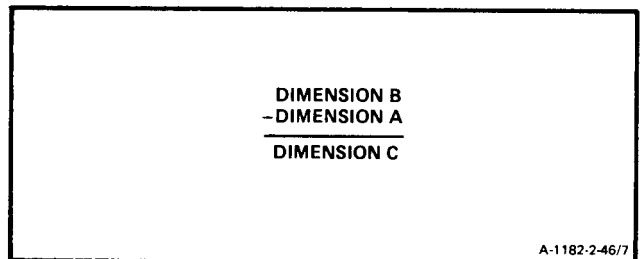

A-1182-2-46/7

GO TO NEXT PAGE

- d. Subtract 0.003 from Dimension C. Record as Dimension C1. Subtract 0.006 from Dimension C. Record as Dimension C2.
 - e. Using micrometer measure the thickness of shims.
 - f. Select shims so total thickness is no less than Dimension C2 and no more than C1 in step d.
5. Apply shortening compound (E46) to surface (13) on housing assembly (7) and to bearing outer race (10).

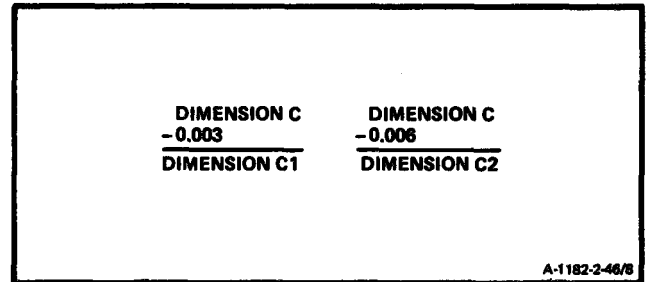

6. Align pin (14) in outer race (10) with slot (15) in housing assembly (7). **Press outer race (10) into housing assembly (7).**

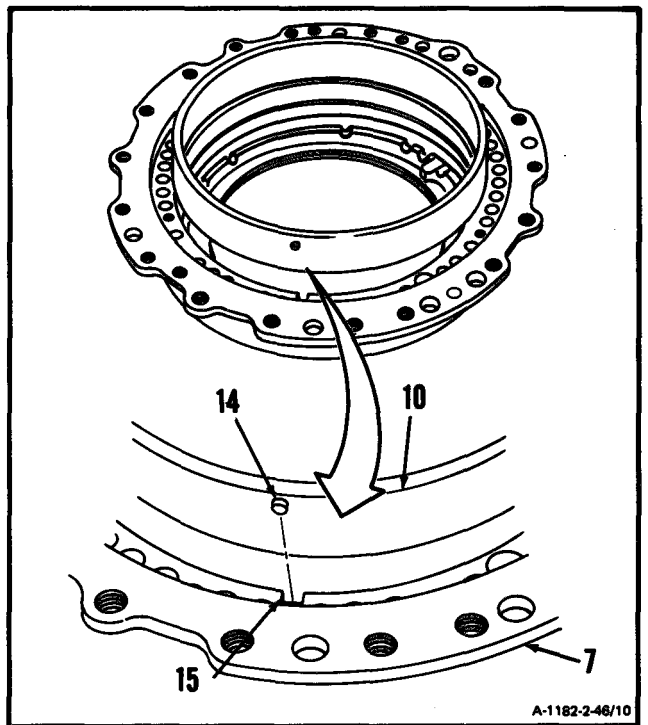
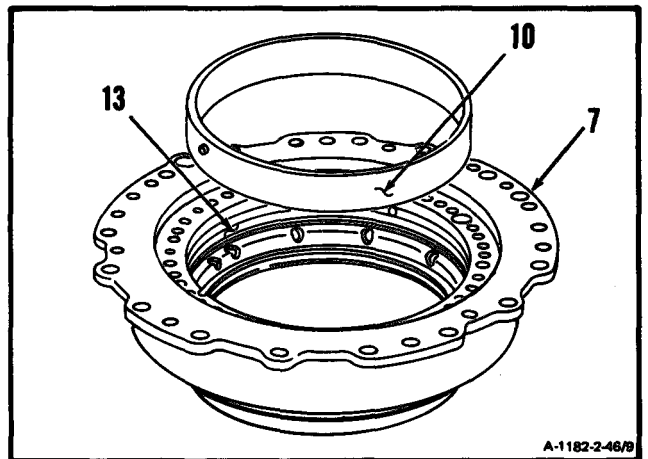

INSPECT

GO TO NEXT PAGE

NOTE

In following step, no more than three shims shall be used. If more than three shims are needed, replace bearing. If more than three shims are still needed, replace housing. If no shim is required, omit steps 7. and 8.

7. Align holes (16) and **install** previously determined **shim(s) (6)** in housing assembly (7).

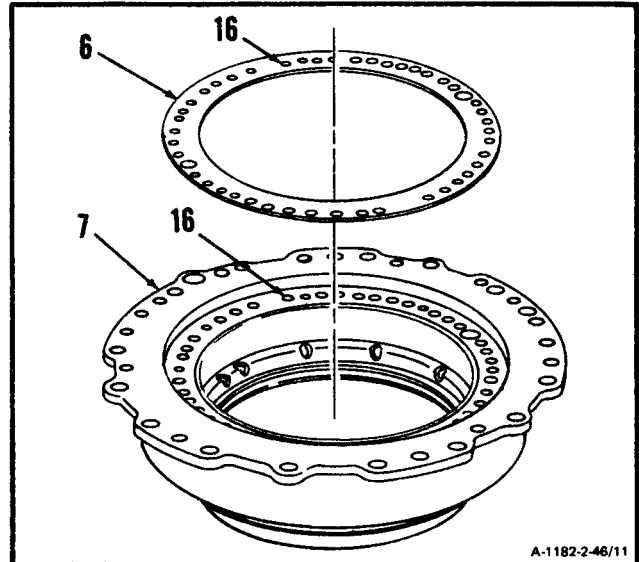

8. Dip bearing inner race (17) in lubricating oil (E32 or E33). Install bearing inner race (17) in outer race (10) with part number facing down.

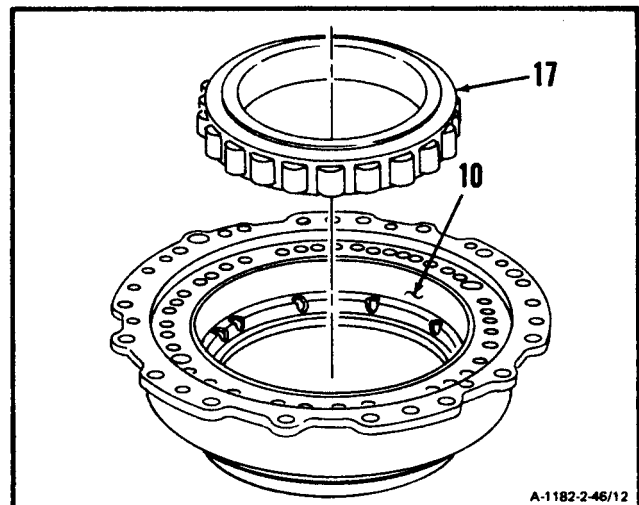
**INSPECT****GO TO NEXT PAGE**

9. With two notches (18) facing up, align two large holes (19) in retaining ring (20) with oil transfer holes (21) in housing assembly (7). **Install retaining ring (20)** in housing assembly (7).

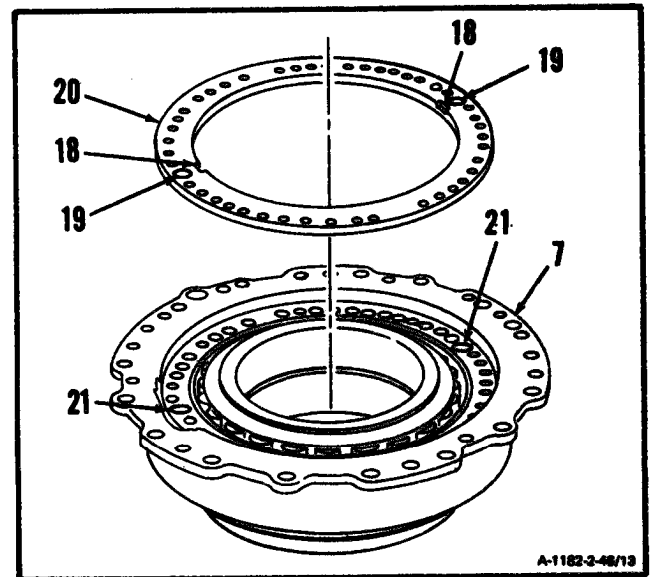

NOTE

Do not lockwire over oil transfer holes.

Install eight bolts (22) in holes (23). Lockwire bolts (22) in pairs. Use lockwire (E29).

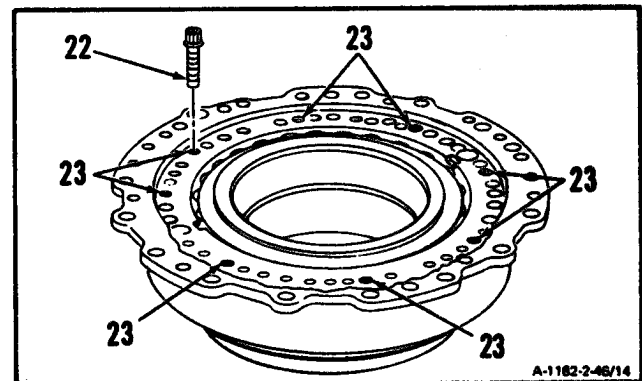

GO TO NEXT PAGE

CAUTION

Seal must be dipped in lubricating oil before installation. Failure to comply will cause damage to seal during dry running period of initial engine starts.

NOTE

If part number is not visible, retaining ring that holds carbon seal elements should face out.

11. Place retainer assembly (24) on sleeve bushing (Appendix E) (25). Dip serviceable seal (26) in lubricating oil (E32 or E33). **Press seal (26) into retainer assembly (24)** with part number facing down. Use oil seal installation tool (Appendix E) (27) and arbor press.

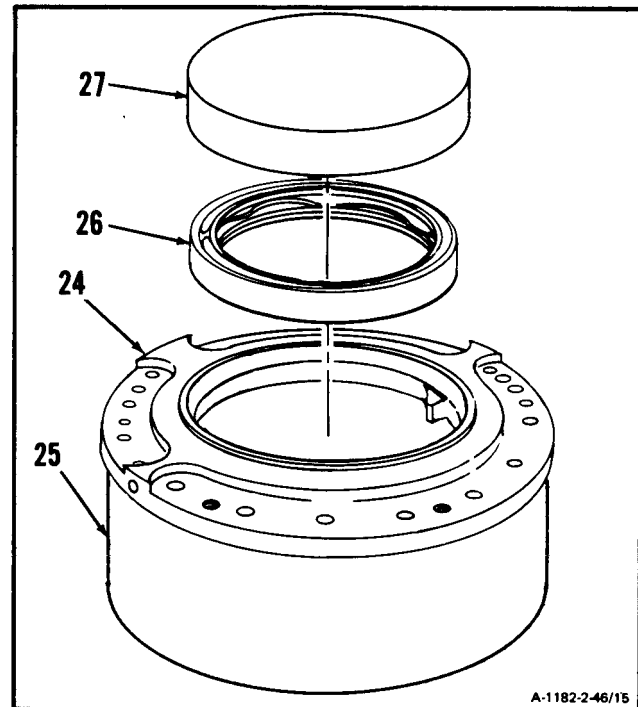

12. **Install retaining ring (28)** in retainer assembly (24).

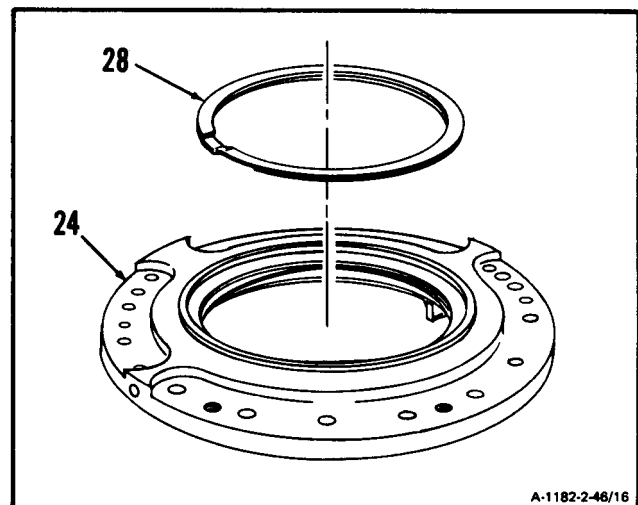

GO TO NEXT PAGE

2-46 ASSEMBLE NO. 2 BEARING PACKAGE (AVIM) (Continued)

2-46

13. Install packings (29) on two oil transfer couplings (30).

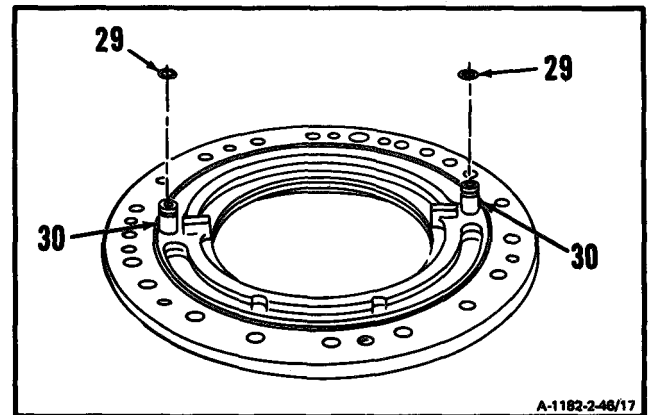

14. Install gasket (31) in oil port (32).
15. Install gasket (33) in oil port (34).
16. Install gasket (35) in groove (36).

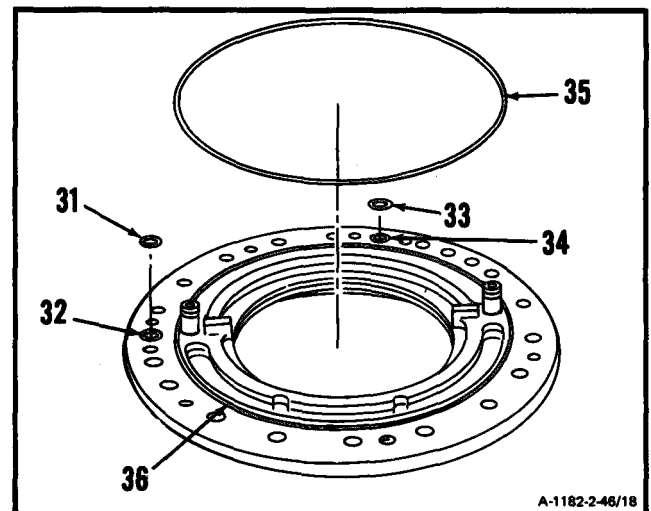

INSPECT

GO TO NEXT PAGE

17. Align oil tubes on retainer assembly (24) with oil transfer holes (21) in housing assembly (7). **Install retainer assembly (24)** and 18 bolts (37) on housing assembly (7). Torque to 85 inch-pounds. Lockwire bolts (37). Use lockwire (E29).

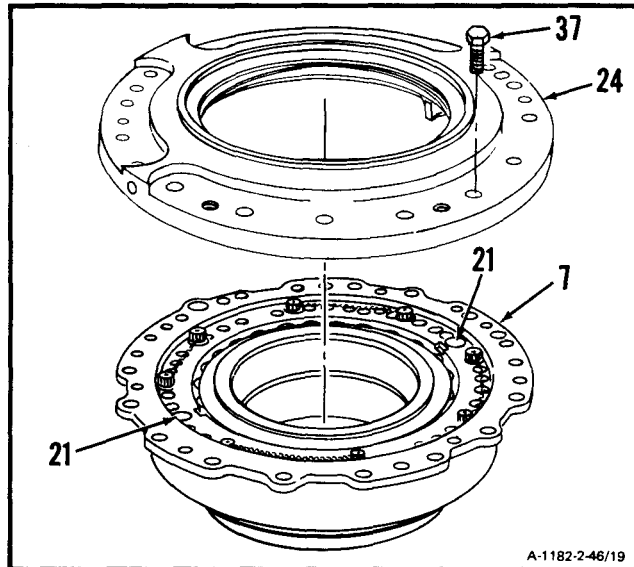

18. **Install bearing liner (38)** in retainer assembly (24).

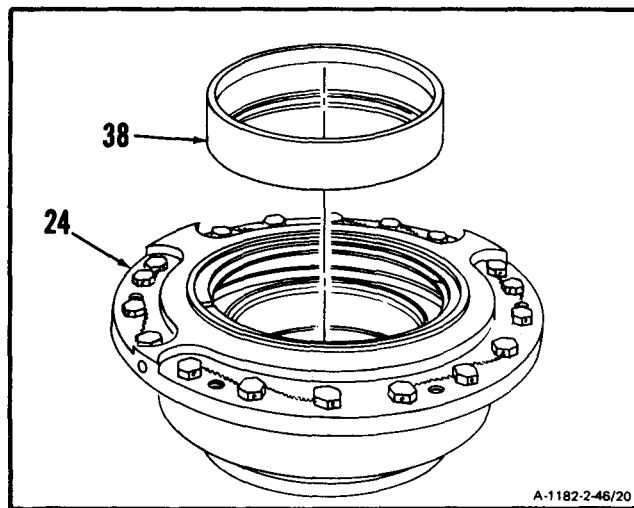

INSPECT

FOLLOW-ON MAINTENANCE:

None

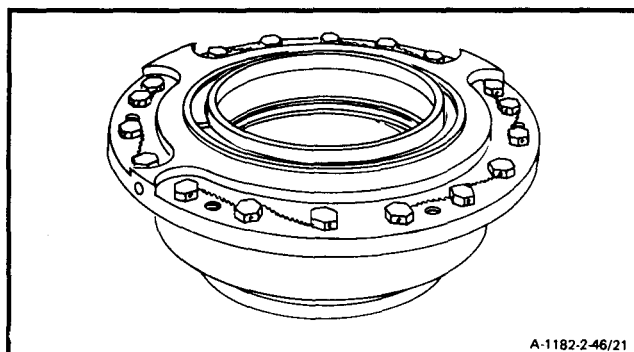

END OF TASK

2-47 INSTALL NO. 2 BEARING PACKAGE (AVIM)

2-47

INITIAL SETUP

Applicable Configurations:

All

Tools:Powerplant Mechanic's Tool Kit,
NSN 5180-00-323-4944Technical Inspection Tool Kit,
NSN 5180-00-323-5114

Installing Tool (T26)

Personnel Required:

68910 Aircraft Powerplant Repairer

68B30 Aircraft Powerplant Inspector

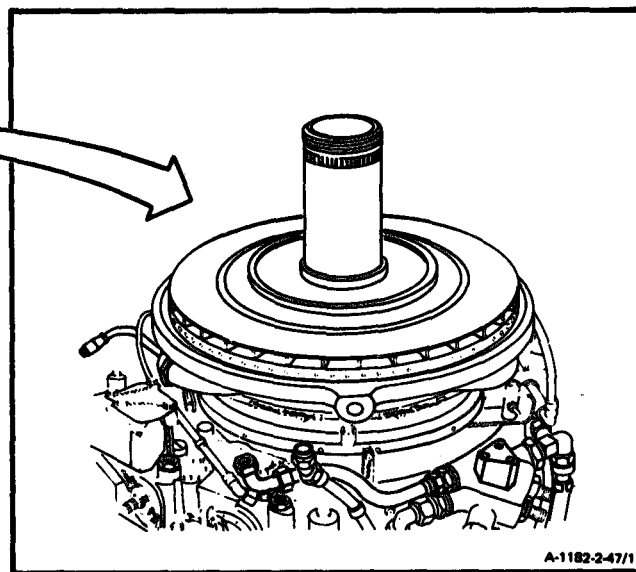
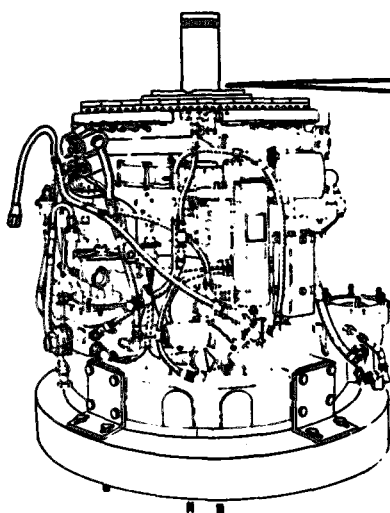

GO TO NEXT PAGE

CAUTION

Be careful when installing bearing package. Carbon elements inside seals could easily break. This would cause oil leakage and damage to engine.

1. Place No. 2 bearing package (1) on compressor shaft (2).

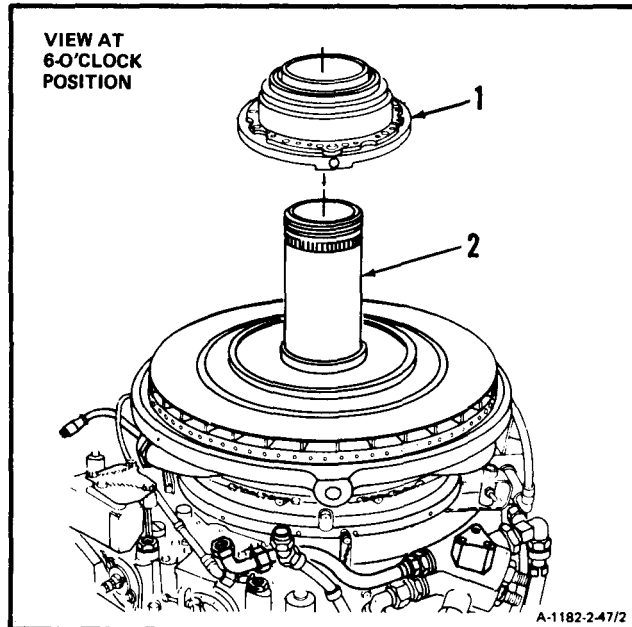

2. Install installing tool (T26) (3) as follows:

- a. Place installing tool (T26) (3) on compressor shaft (2).
- b. Hold handle (4). Turn handle (5) clockwise until sleeve (6) is completely threaded on compressor shaft (2).

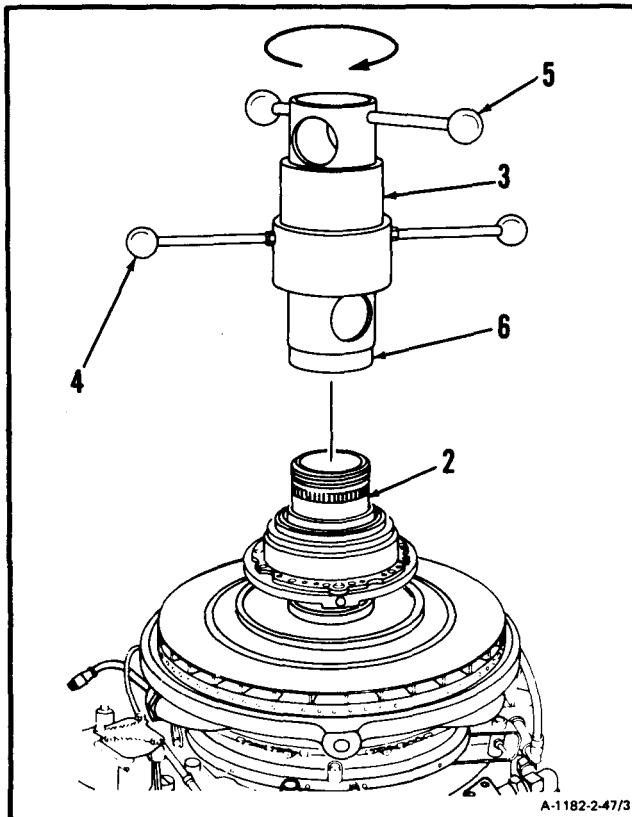

GO TO NEXT PAGE

2-47 INSTALL NO. 2 BEARING PACKAGE (AVIM) (Continued)

2-47

3. Hold handle (5) and turn handle (4) clockwise until No. 2 bearing package (1) is firmly seated on compressor shaft (2).

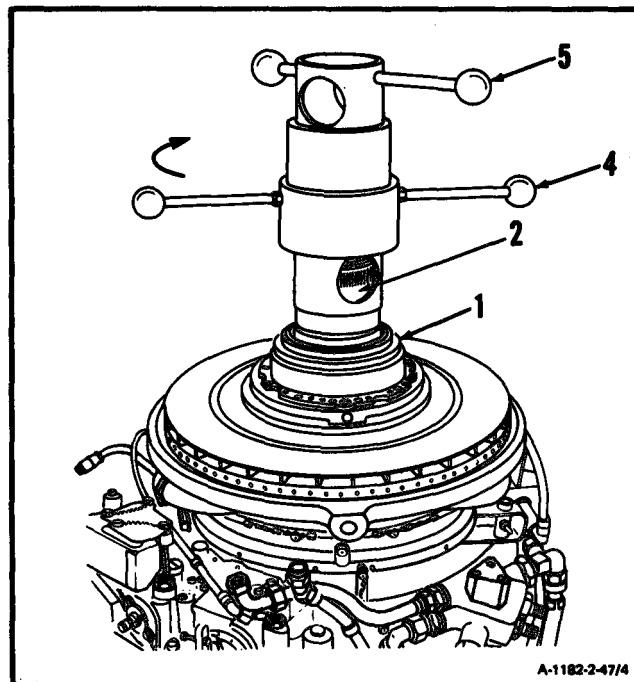

4. Remove installing tool (T26) (3) as follows:

- a. Turn handle (4) counterclockwise and loosen sleeve (7).
- b. Turn handle (5) counterclockwise and unscrew sleeve (6).
- c. Remove installing tool (T26) (3).

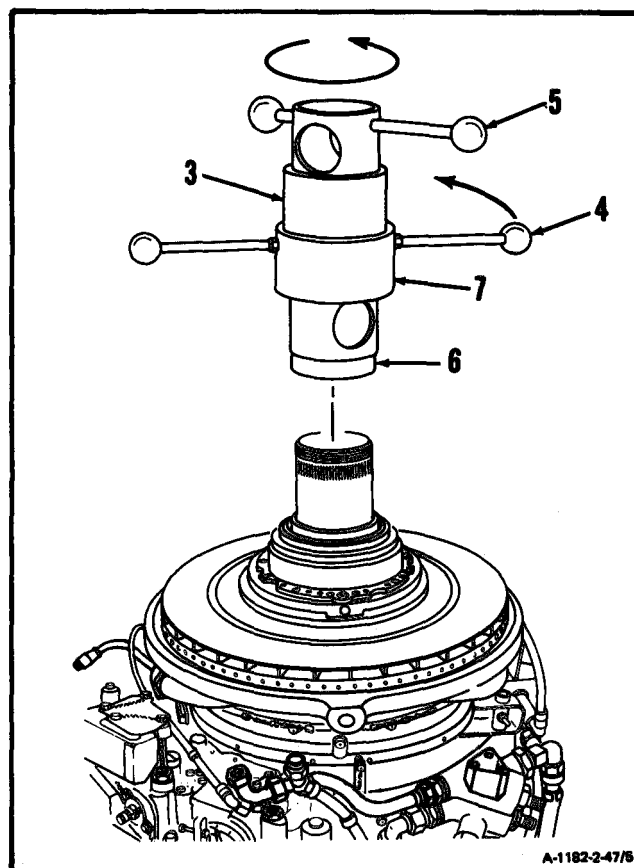

INSPECT

GO TO NEXT PAGE

FOLLOW-ON MAINTENANCE:

- Install Air Diffuser Assembly (Task 2-41).
- Install Diffuser Curl (Task 4-77).
- Install First Turbine Nozzle (Task 4-71).
- Install First Turbine Disc Assembly (Task 4-66).
- Install Second Turbine Nozzle, Spacer and Case (Task 4-61).
- Install Second Turbine Disc Assembly (Task 4-56).
- Install Combustion Section and Power Turbine (Task 3-8).
- Service Engine Oil System (Task 1-74).

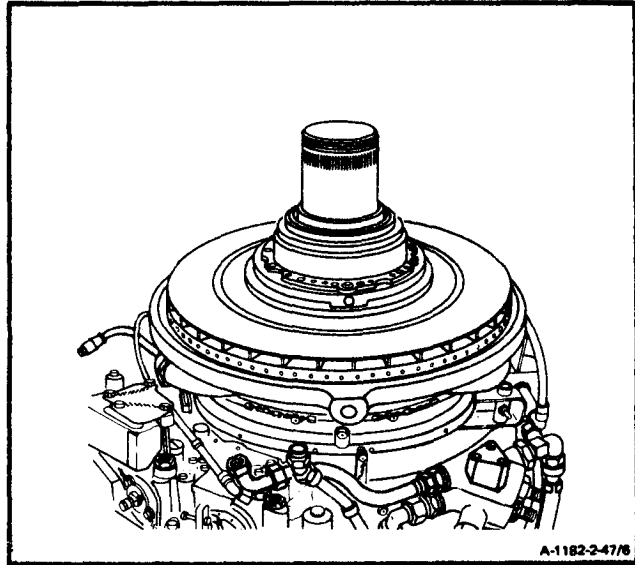
**END OF TASK**

Section IX. OUTPUT SHAFT SEAL AND HOUSING ASSEMBLY - MAINTENANCE PROCEDURES

2-43 REMOVE OUTPUT SHAFT SEAL AND HOUSING ASSEMBLY

2-48

INITIAL SETUP

Applicable Configurations:

All

Tools:

Powerplant Mechanic's Tool Kit,
NSN 5180-00-323-4944
Handling Tool (T16) (3)

Materials:

Wiping Rag (E58)

Personnel Required:

68B10 Aircraft Powerplant Repairer

References:

Task 2-50

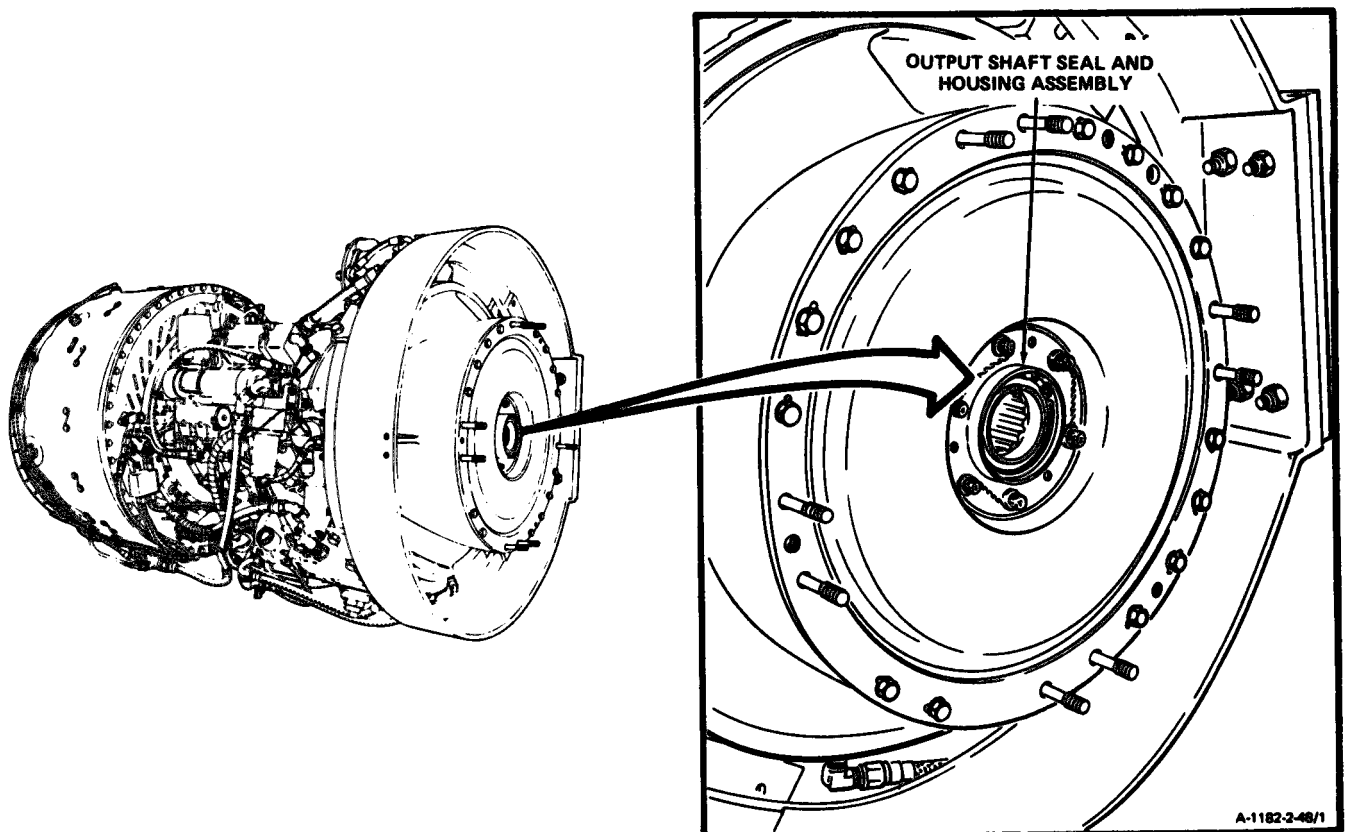

GO TO NEXT PAGE

NOTE

Before removing output shaft seal and housing assembly, check for evidence of oil leakage from seal. If evidence of leakage is found, have aircraft powerplant inspector examine seal housing assembly in accordance with Task 2-50.

1. Remove lockwire and six bolts (1).

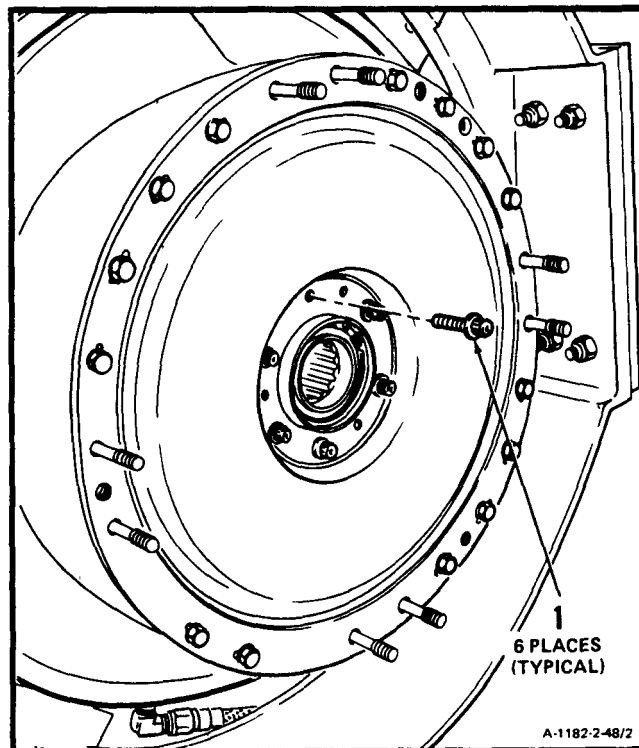

GO TO NEXT PAGE

2. Install three handling tools (T16) or (T17) (2) in three threaded holes (3) in output shaft seal and housing assembly (4).

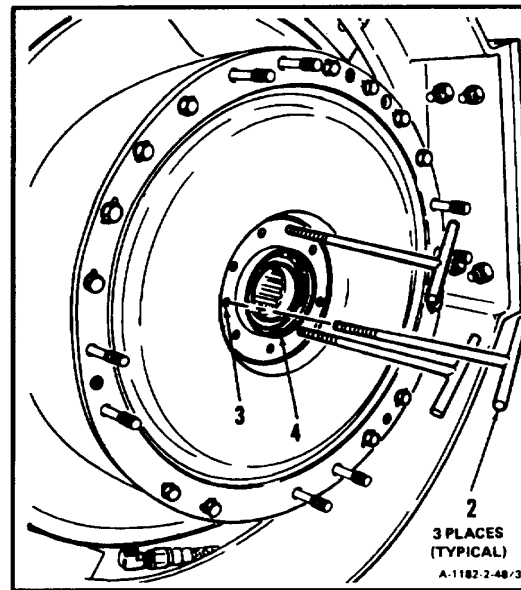

GO TO NEXT PAGE

Change 6 2-433

CAUTION

In following step 3, be sure to remove output shaft seal and housing assembly carefully and evenly. Carbon elements inside seals could easily break. This would result in oil leakage and damage to engine.

3. Tighten three handling tools (T16) or (T17) (2) evenly. Separate output shaft seal and housing assembly (4) from inlet housing cover assembly (5).

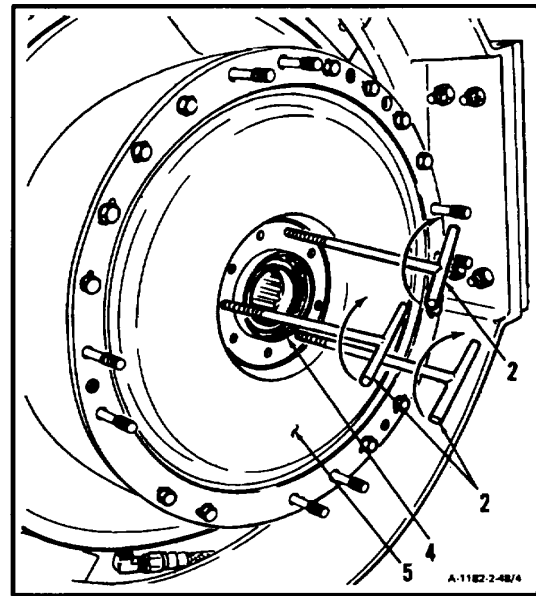

4. Remove output shaft seal and housing assembly (4), shim (6) and two packings (7). Remove three handling tools (T16) or (T17) (2).

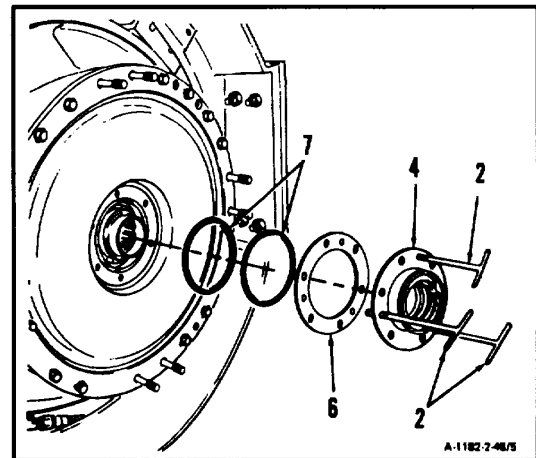

GO TO NEXT PAGE

2-48 REMOVE OUTPUT SHAFT SEAL AND HOUSING ASSEMBLY (Continued)

2-48

2. Install three handling tools (T16) (2) in three threaded holes (3) in output shaft seal and housing assembly (4).

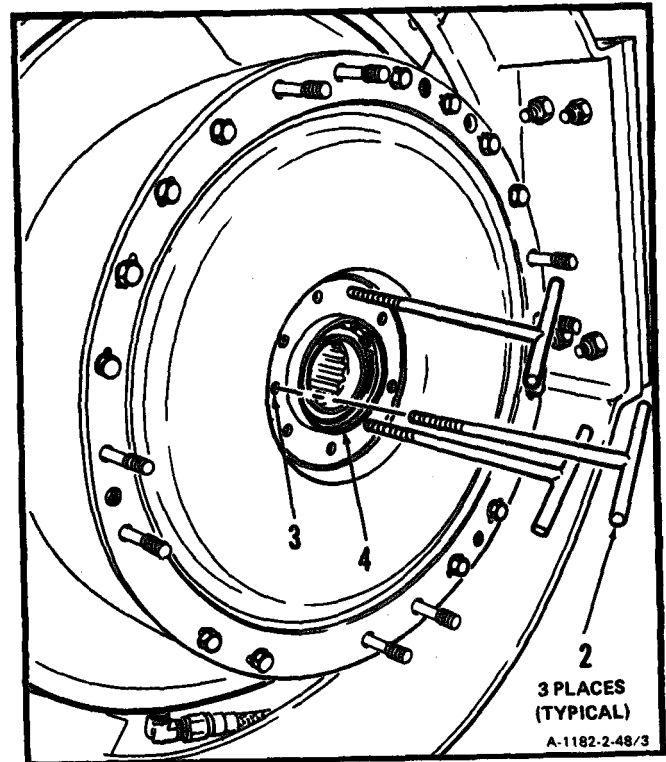

GO TO NEXT PAGE

CAUTION

In following step 3., be sure to remove output shaft seal and housing assembly carefully and evenly. Carbon elements inside seals could easily break. This would result in oil leakage and damage to engine.

3. Tighten three handling tools (T16) (2) evenly. Separate output shaft-seal and housing assembly (4) from inlet housing cover assembly (5).

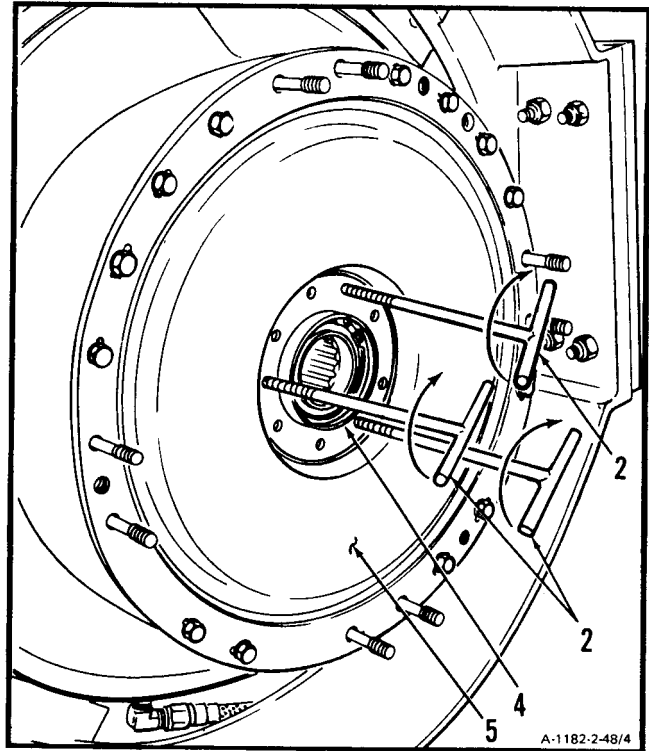

4. Remove output shaft seal and housing assembly (4), shim (6) and two packings (7). Remove three handling tools (T16) (2).

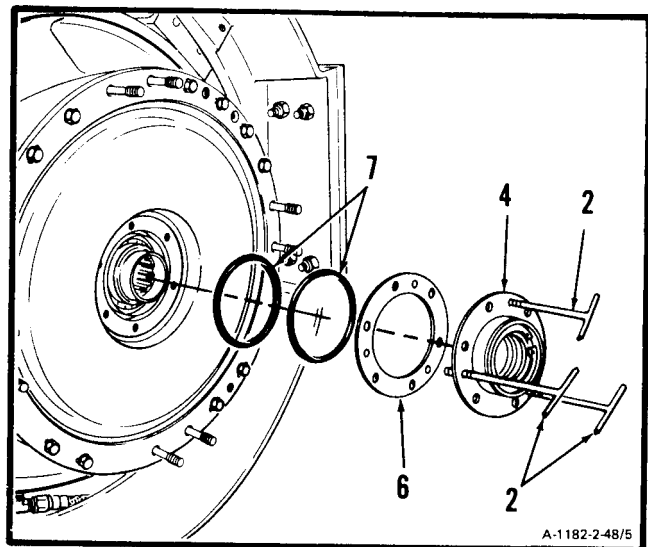

GO TO NEXT PAGE

2-48 REMOVE OUTPUT SHAFT SEAL AND HOUSING ASSEMBLY (Continued)

2-48

FOLLOW-ON MAINTENANCE:

None

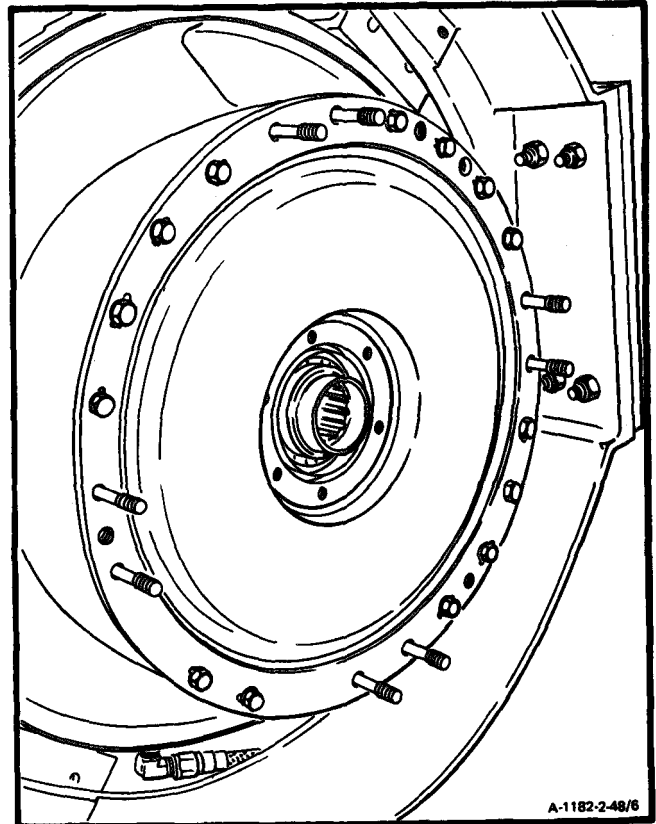

END OF TASK

INITIAL SETUP

Applicable Configurations:

All

Tools:

- Powerplant Mechanic's Tool Kit,
NSN 5180-00-323-4944
- Goggles
- Compressed Air Source

Materials:

- Dry Cleaning Solvent (E17)
- Glove (E20)
- Lint-Free Cloth (E26)

Personnel Required:

68B10 Aircraft Powerplant Repairer

Equipment Condition:

- Off Engine Task
- Output Shaft Seal and Housing Assembly
Removed (Task 2-48)

General Safety Instructions:

Dry cleaning solvent (EI 7) is flammable and toxic. it can irritate skin and cause burns. Use only in well-ventilated area, away from heat and open flame. In case of contact, immediately flush skin or eyes with water for at least 15 minutes, Get medical attention for eyes.

1. Wear gloves (E20). immerse output shaft seal housing assembly (1) in dry cleaning solvent (E17) and agitate. Use brush on inside surfaces (2).
2. Wipe dry, Use clean, dry, lint-free cloth (E26).

WARNING

When using compressed air for cleaning, use approved protective equipment for eyes and face. Do not use more than 30 psig air pressure. Do not direct air toward yourself or another person. Failure to comply could result in injury to eyes or skin. In case of injury, get medical attention.

3. Wear goggles. Blow dry inside surfaces (2) using clean, dry compressed air.

FOLLOW-ON MAINTENANCE:

Inspect Output Shaft Seal and Housing Assembly (Task 2-50).

END OF TASK

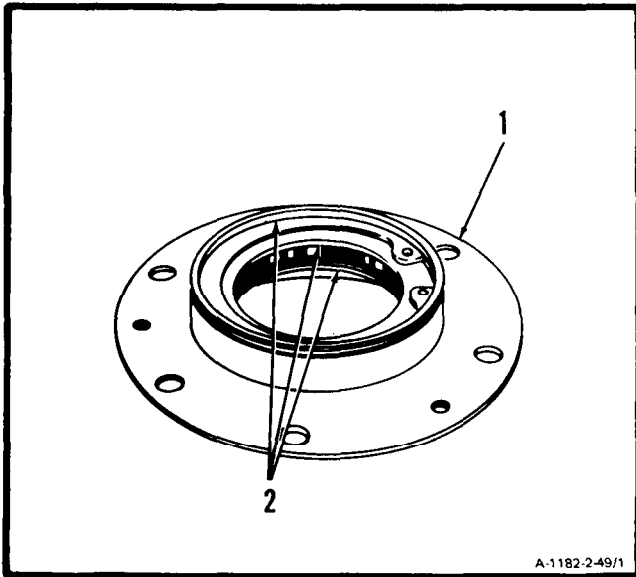

2-50 INSPECT OUTPUT SHAFT SEAL AND HOUSING ASSEMBLY

2-50

INITIAL SETUP

Applicable Configurations:

All

Tools:

Technical inspection Tool Kit,
NSN 5180-00-323-5114

Materials:

None

Personnel Required:

68B30 Aircraft Powerplant Inspector

Equipment Condition:

Off Engine Task

1. Inspect output shaft seal and housing assembly (1) as follows:

- a. There shall be no evidence of oil leakage.
- b. There shall be no cracks.

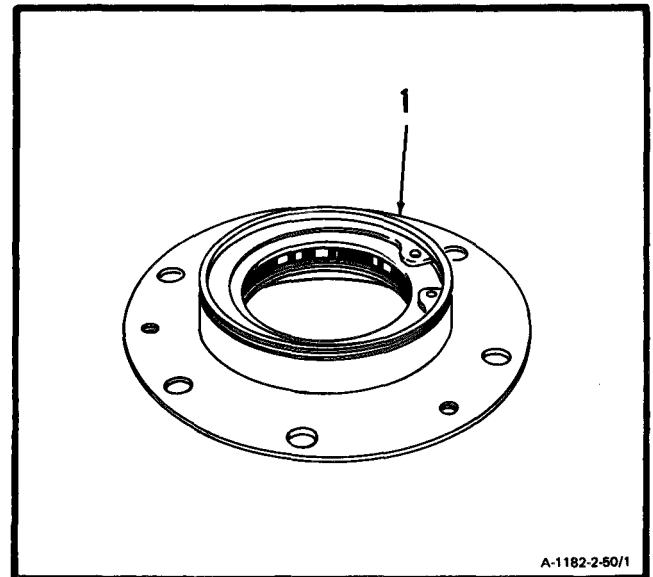

2. Inspect oil seal (2). There shall be no cracks or chips in three carbon elements (3).

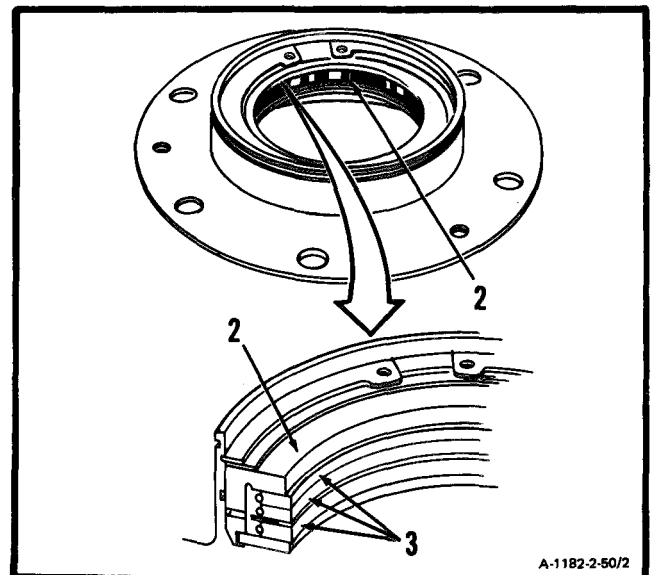

FOLLOW-ON MAINTENANCE:

None

END OF TASK

2-51 REPAIR OUTPUT SHAFT SEAL AND HOUSING ASSEMBLY

2-51

INITIAL SETUP

Applicable Configurations:

All

Tools:

Powerplant Mechanic's Tool Kit,
NSN 5180-00-323-4944
Technical Inspection Tool Kit,
NSN 5180-00-323-5114
Installation Tool (T7)
Sleeve, 2-1/2 Inch Diameter (Appendix E)
Arbor Press
Goggles
Compressed Air Source
Outside Micrometer Caliper Set
Retaining Ring Pliers

Materials:

Dry Cleaning Solvent (E17)
Gloves (E20)
Lint-Free Cloth (E26)

Parts:

Packings
Seal

Personnel Required:

68610 Aircraft Powerplant Repairer
68B30 Aircraft Powerplant Inspector

References:

TM 55-2840-254-23P

Engine Condition:

Off Engine Task

1. Repair output shaft seal and housing assembly if oil leakage or cracks are evident as follows:
 - a. **Remove retaining ring (1) and shim (2) from housing (3).**

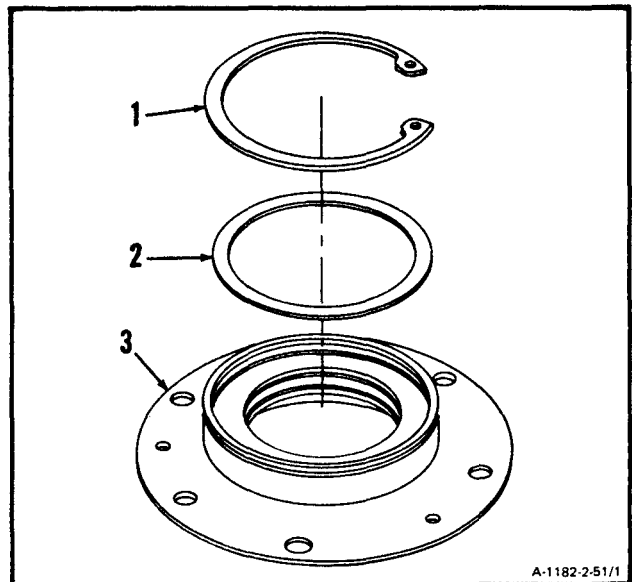
**GO TO NEXT PAGE**

- b. Press oil seal (4) out of housing (5) from aft side (6). Use 2-1/2 inch diameter sleeve (7).

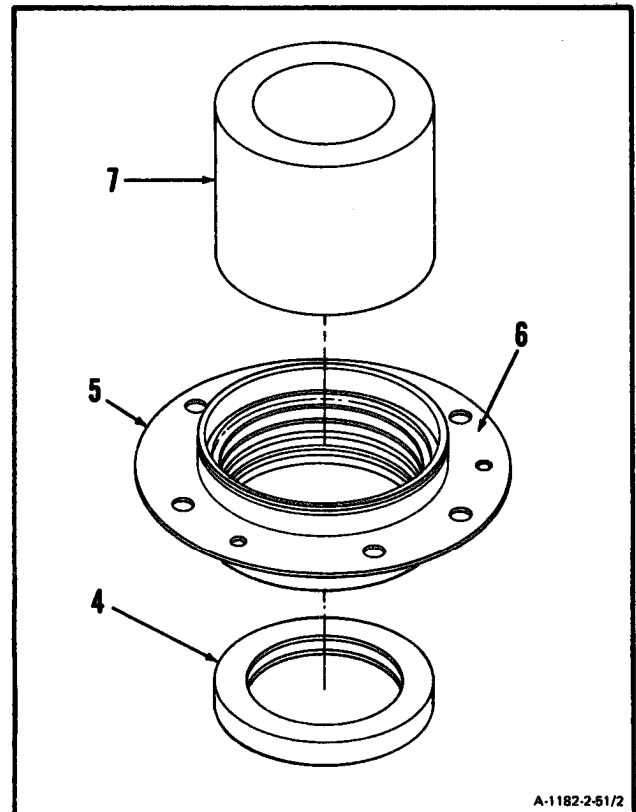

- c. Remove two packings (8).

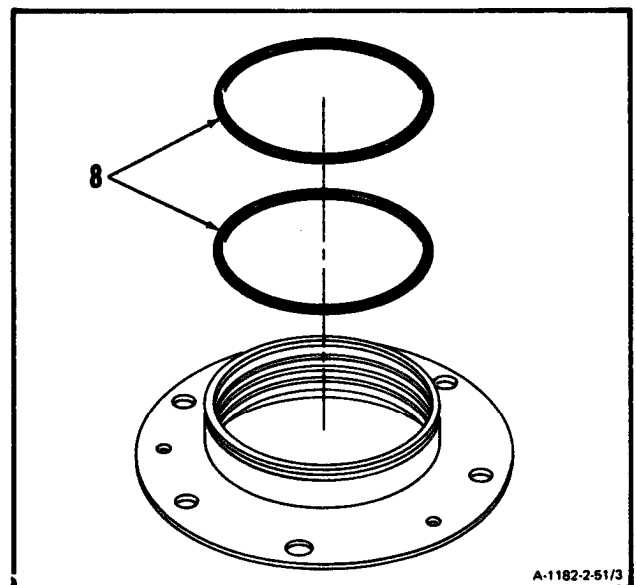

GO TO NEXT PAGE

d. **Clean housing (5)** as follows:

WARNING

Dry cleaning solvent (E17) is flammable and toxic. It can irritate skin and cause burns. Use only in well-ventilated area, away from heat and open flame. In case of contact, immediately flush skin or eyes with water for at least 15 minutes. Get medical attention for eyes.

- (1) Wear gloves (E20). Immerse and agitate in dry cleaning solvent (E17). Use brush in seven grooves (9).
- (2) Wipe dry using clean dry lint-free cloth (E26).

WARNING

When using compressed air for cleaning, use approved protective equipment for eyes and face. Do not use more than 30 psig air pressure. Do not direct air toward yourself or another person. Failure to comply could result in injury to eyes or skin. In case of injury, get medical attention.

- (3) Wear goggles. Blow dry seven grooves (9) and 16 air-bleed holes (10).

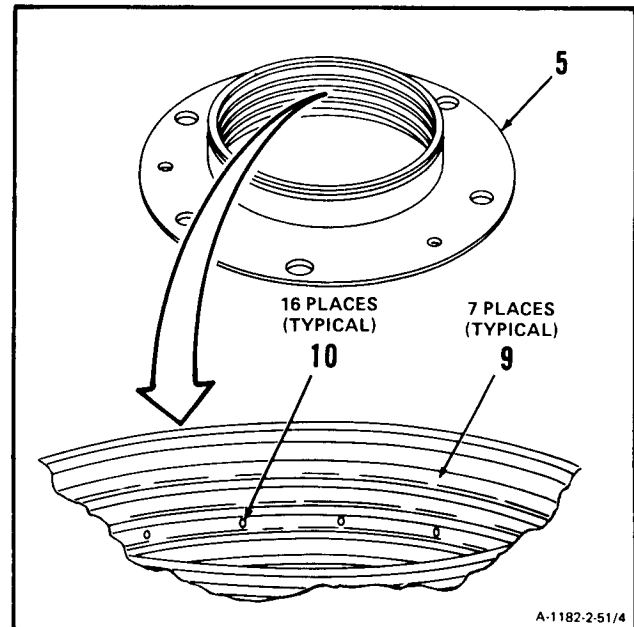

GO TO NEXT PAGE

2-51 REPAIR OUTPUT SHAFT SEAL AND HOUSING ASSEMBLY (Continued)

2-51

- e. **Inspect housing (5).** There shall be no cracks. The 16 air-bleed holes (10) shall not be clogged.

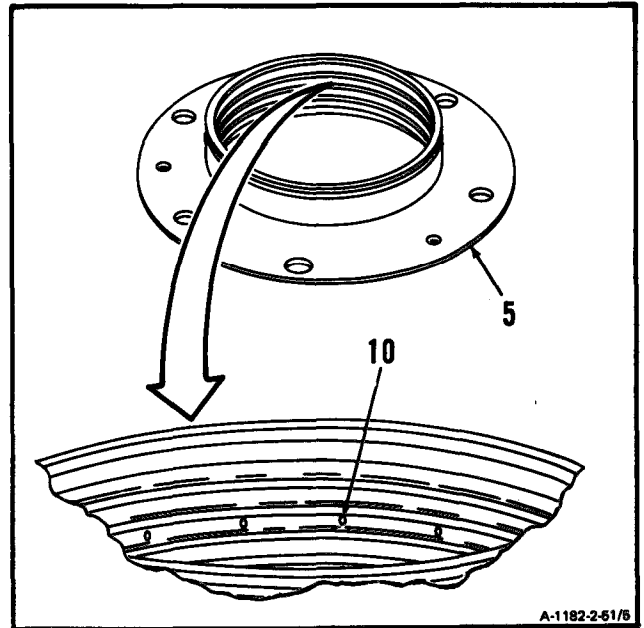

- f. Install two packings (8) in housing (5).

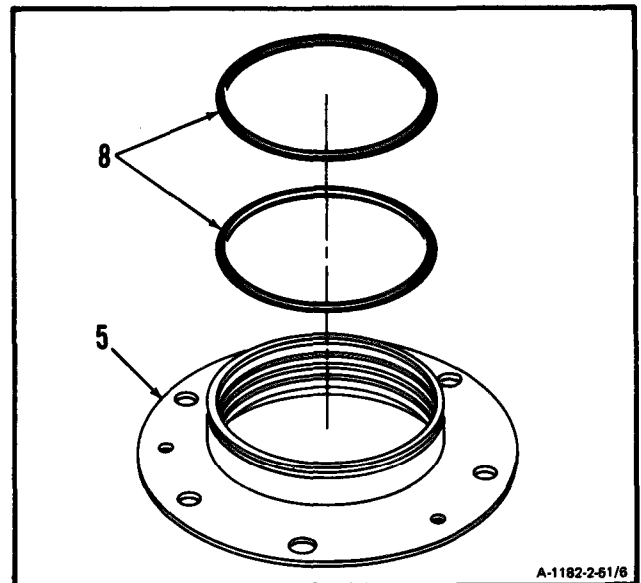

GO TO NEXT PAGE

g. Install oil seal as follows:

- (1) Position housing (5) on ring (11) of installation tool (T7) with aft side (12) seated into recessed I.D. (13).

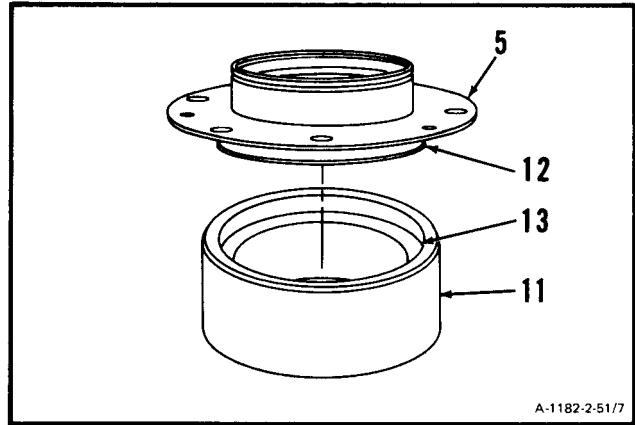

- (2) Position oil seal (4) on housing (5) with face marked OIL SIDE (14) facing down.

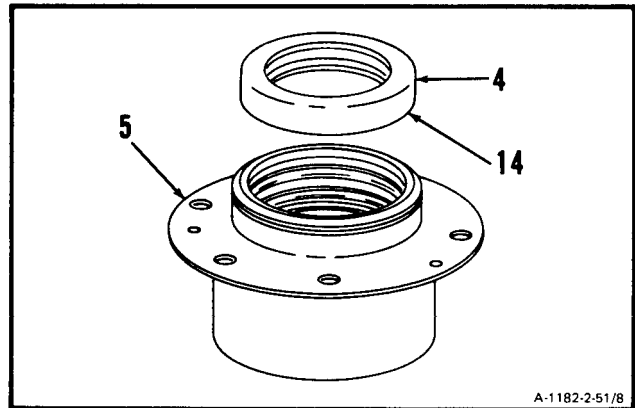

- (3) Position sleeve (15) of installation tool (T7) on oil seal (4) with recessed I.D. (16) facing down.

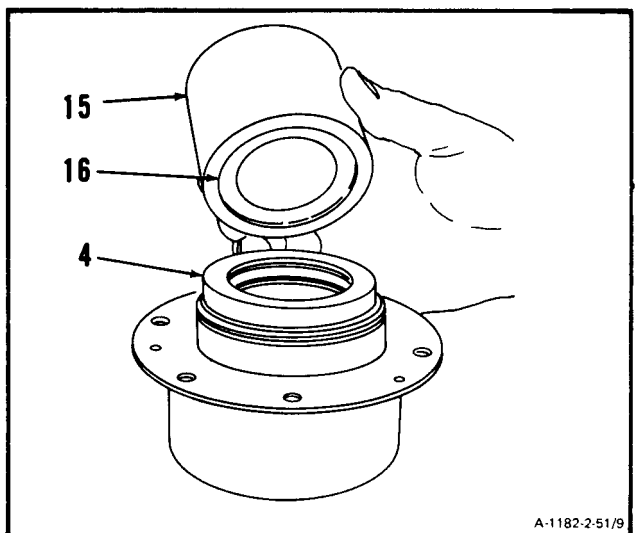

GO TO NEXT PAGE

2-51 REPAIR OUTPUT SHAFT SEAL AND HOUSING ASSEMBLY (Continued)

2-51

- (4) Press oil seal (4) into housing (5).
- (5) Remove sleeve (15) of installation tool (T7).

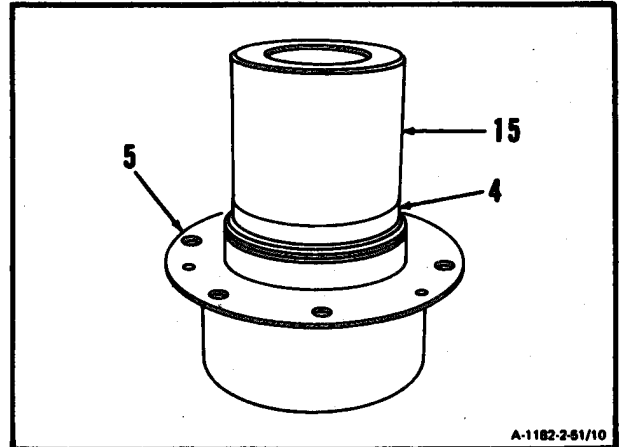

- h. **Temporarily install retaining ring (1)** in groove (17). Seat retaining ring (1) against groove upper lip (18).

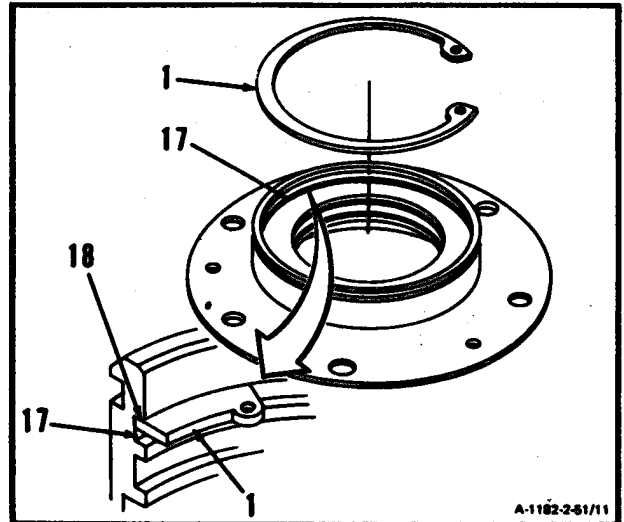

- i. Measure gap between oil seal (4) and retaining ring (1).

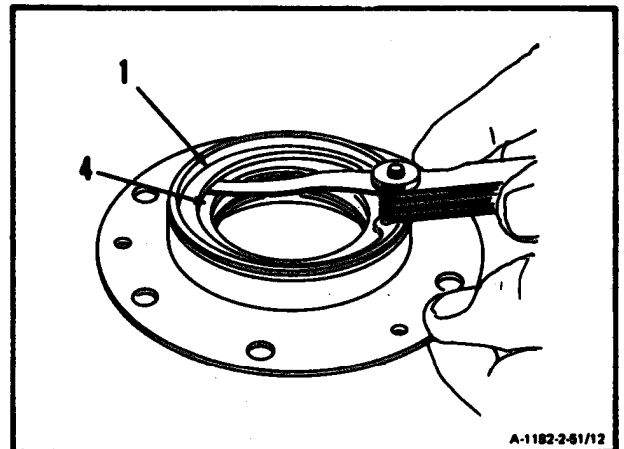

INSPECT

GO TO NEXT PAGE

j. Find gap measurement in shim selection table. Read across to find shim thickness.

SHIM THICKNESS	
If Gap Measures	Shim Thickness Required
Inches	Inches
0.005	0.004
0.006	0.004
0.007	0.006
0.008	0.006
0.009	0.008
0.010	0.008
0.011	0.010
0.012	0.010
0.013	0.012
0.014	0.012
0.015	0.014
0.016	0.014
0.017	0.016
0.018	0.016
0.019	0.018
0.020	0.018
0.021	0.020
0.022	0.020
0.023	0.022
0.024	0.022
0.025	0.024
0.026	0.024

GO TO NEXT PAGE

k. Measure thickness of shim (2) and check against shim selection table.

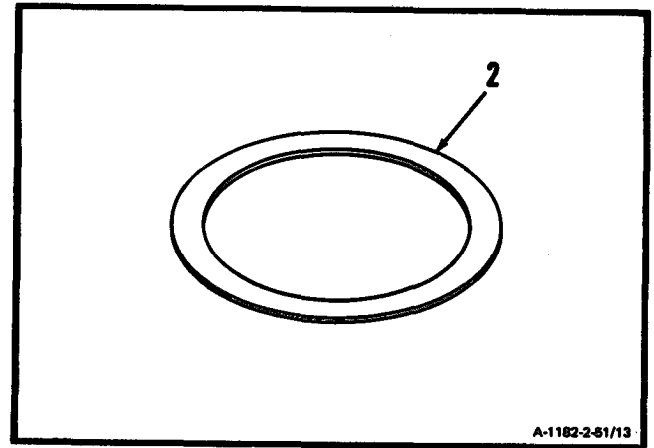

l. Remove retaining ring (1).

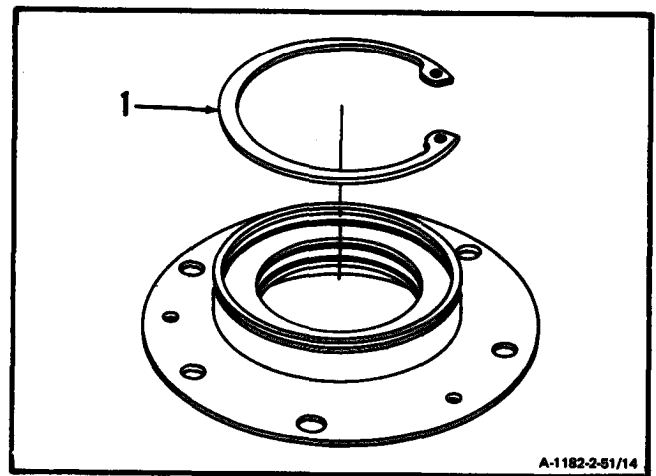

m. Install shim (2) and retaining ring (1).

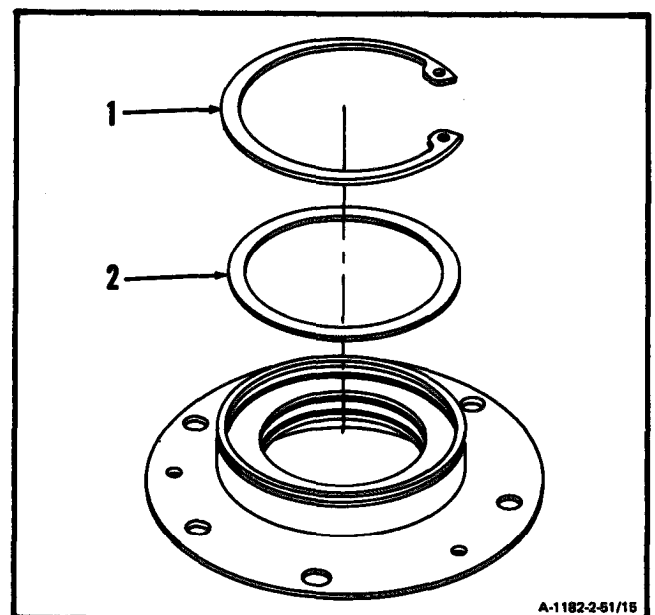

GO TO NEXT PAGE

- n. Check gap between shim (2) and retaining ring (1). Gap shall not be more than 0.003-inch.

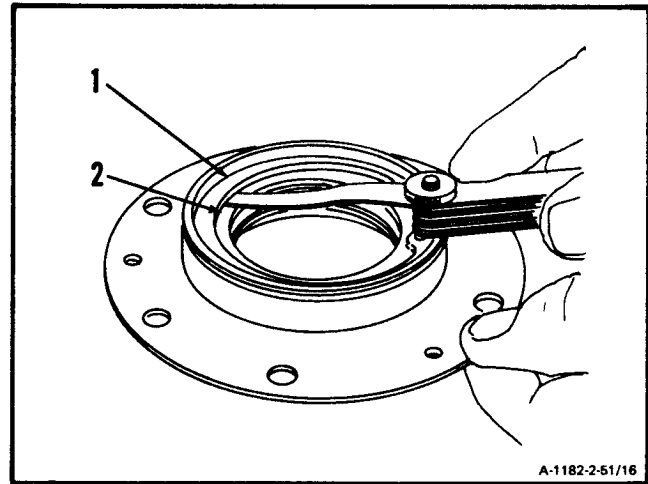
**INSPECT**

FOLLOW-ON MAINTENANCE:

None

END OF TASK

2-446

2-52 INSTALL OUTPUT SHAFT SEAL AND HOUSING ASSEMBLY

2-52

INITIAL SETUP

Applicable Configurations:

All

Tools:

Powerplant Mechanic's Tool Kit,
NSN 5180-00-323-4944
Technical Inspection Tool Kit,
NSN 5180-00-323-5114
Alignment Pin (T2) (2)
Installation Tool (T8)
Micrometer Depth Gage.
Outside Micrometer Caliper Set

Materials:

Lockwire (E29)

Parts:

Packings
Shim

Personnel Required:

68B10 Aircraft Powerplant Repairer
68B30 Aircraft Powerplant Inspector

References:

TM 55-2840-254-23P

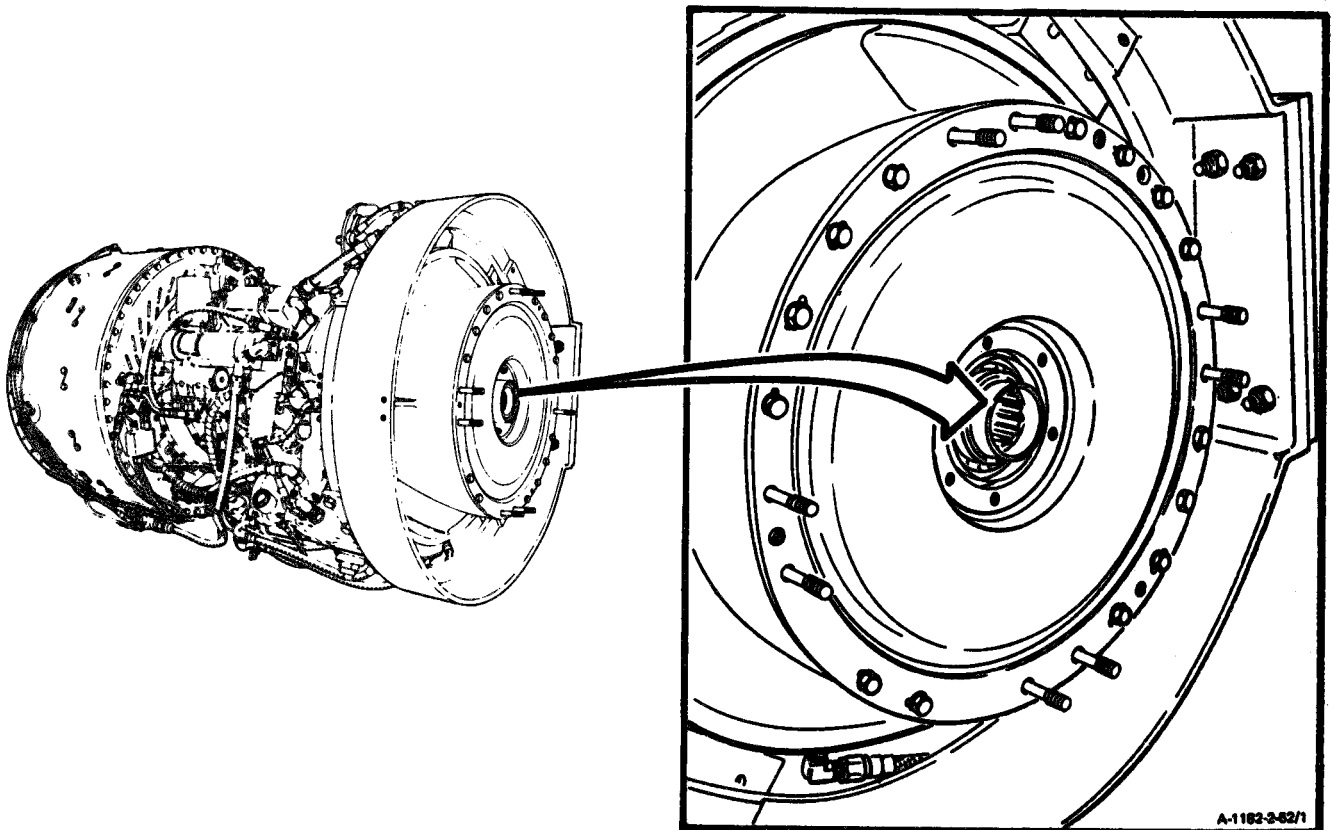

GO TO NEXT PAGE

1. Determine shim needed as follows:
 - a. Push output shaft (1) rearward and **measure depth from flange (2) to edge of bearing (3)**. Use micrometer depth gage.

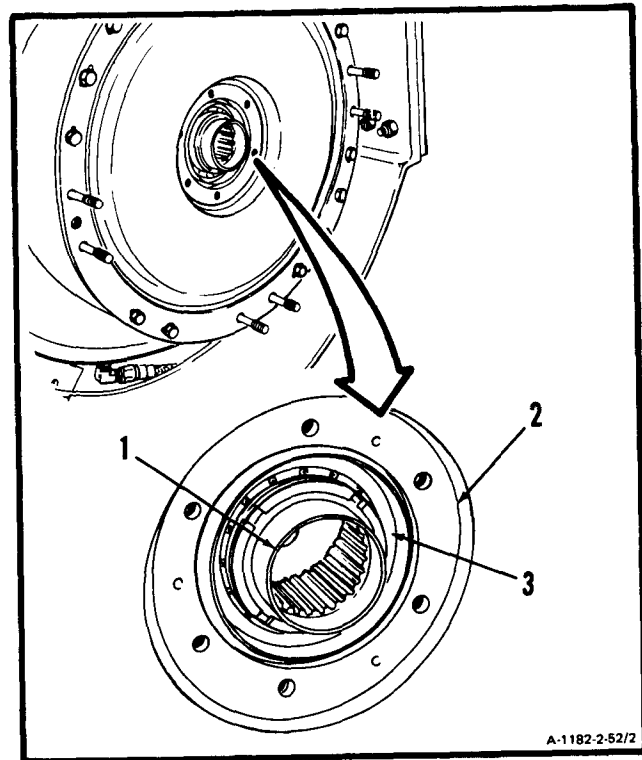

GO TO NEXT PAGE

- b. Find depth measured in shim selection table.
Read across to find shim thickness required.

SHIM SELECTION TABLE	
Depth Measured	Shim Thickness Required
Inch	Inch
0.510	0.038
0.511	0.036
0.512	0.036
0.513	0.034
0.514	0.034
0.515	0.032
0.516	0.032
0.517	0.030
0.518	0.030
0.519	0.028
0.520	0.028
0.521	0.026
0.522	0.026
0.523	0.024
0.524	0.024
0.525	0.022
0.526	0.022
0.527	0.020
0.528	0.020
0.529	0.018
0.530	0.018
0.531	0.016
0.532	0.016
0.533	0.014
0.534	0.014
0.535	0.012
0.536	0.012
0.537	0.010
0.538	0.010
0.539	0.008
0.540	0.008

GO TO NEXT PAGE

2. Prepare shim (4) as follows:

- a. Peel off layers (5) as required to obtain shim thickness required.
- b. **Measure thickness of shim (4)** and check against shim selection table. Use outside micrometer caliper.

INSPECT

3. Install packing (6) in groove (7) on output shaft seal housing assembly (8).

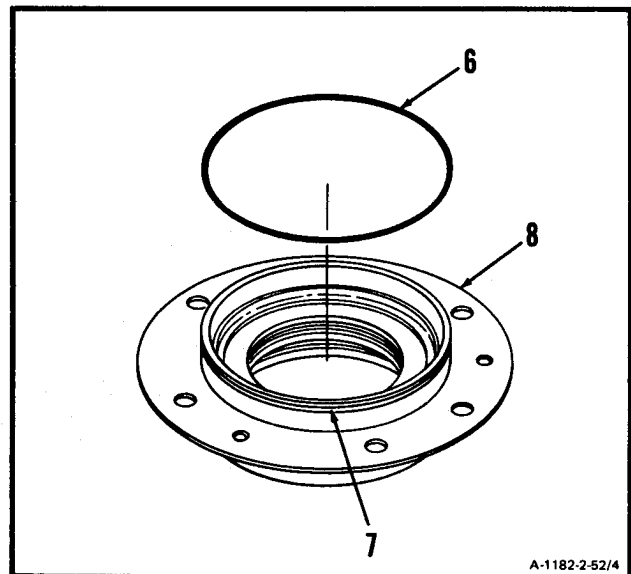
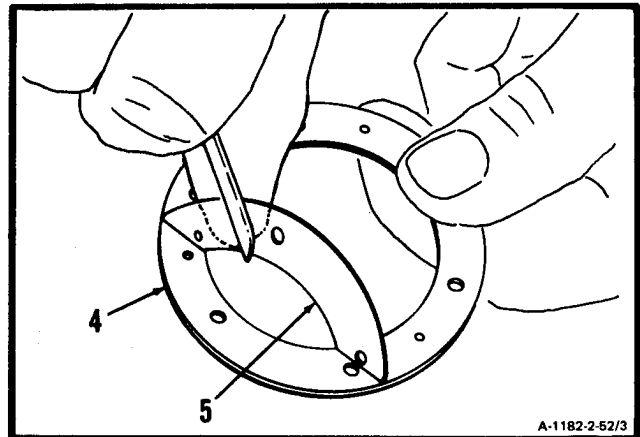
**GO TO NEXT PAGE**

2-52 INSTALL OUTPUT SHAFT SEAL AND HOUSING ASSEMBLY (Continued)

2-52

4. Install packing (9) in groove (10) on inlet housing cover assembly (11).

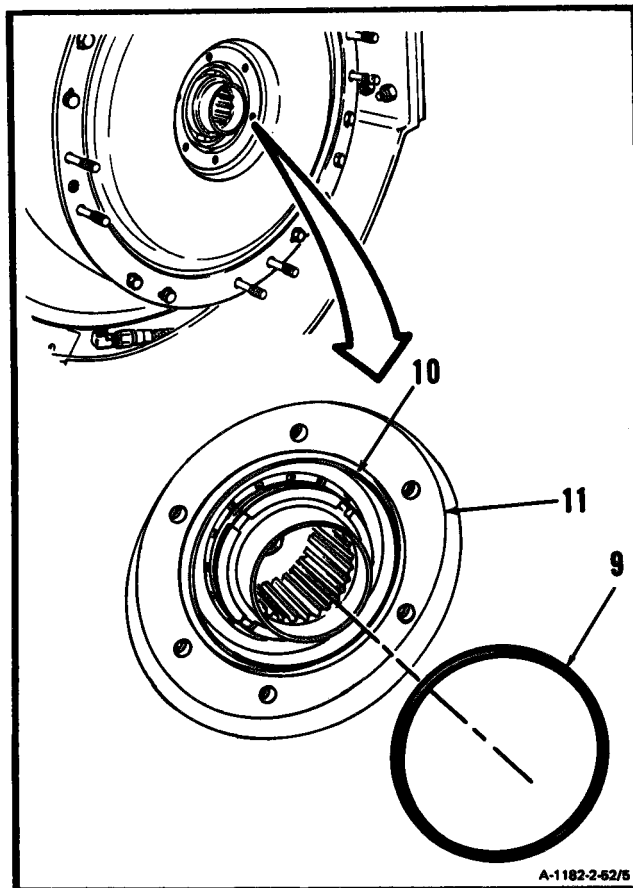

5. Install two alignment pins (T2) (12) in holes (13).

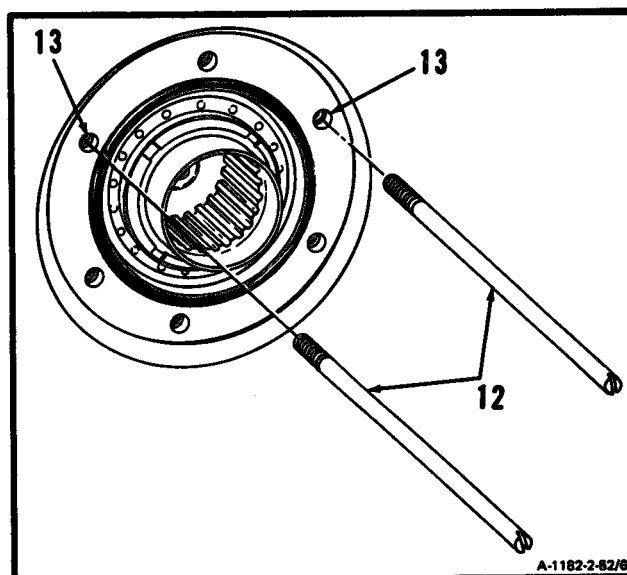

GO TO NEXT PAGE

6. Using two alignment pins (T2) (12), install shim (4).

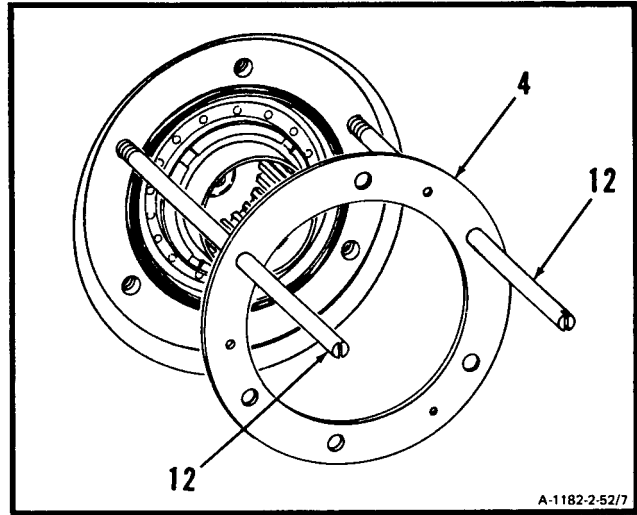

7. Install installation tool (T8) (14) on output shaft (1).

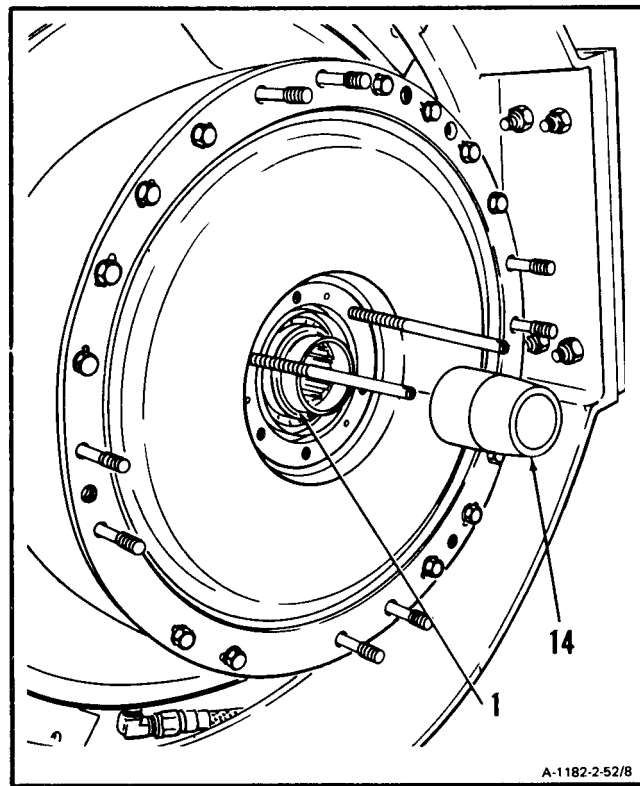

GO TO NEXT PAGE

2-52 INSTALL OUTPUT SHAFT SEAL AND HOUSING ASSEMBLY (Continued)

2-52

CAUTION

When installing seal and housing assembly, be careful not to damage seals. Failure to comply will cause oil leakage.

8. Using two alignment pins (T2) (12) and installation tool (T8) (14), **install output shaft seal and housing assembly (8)**. Remove installation tool and alignment pins.

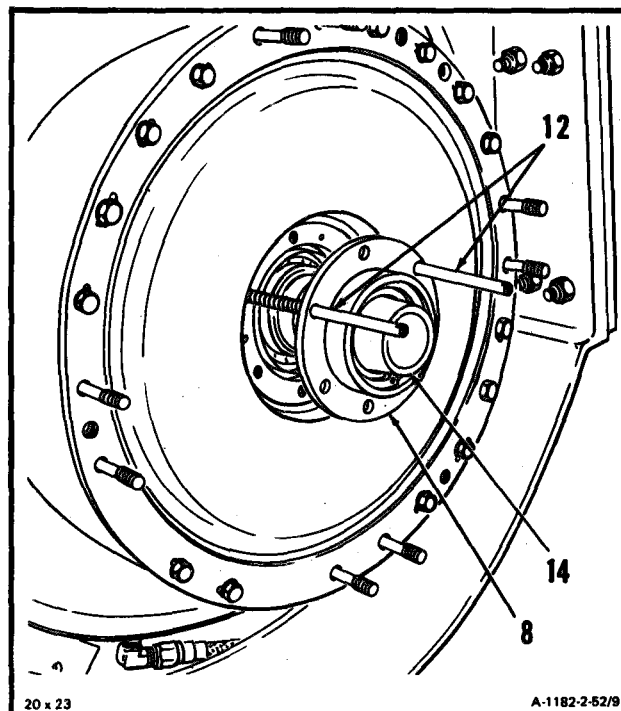

9. Install six bolts (15). Do not lockwire bolts at this time.

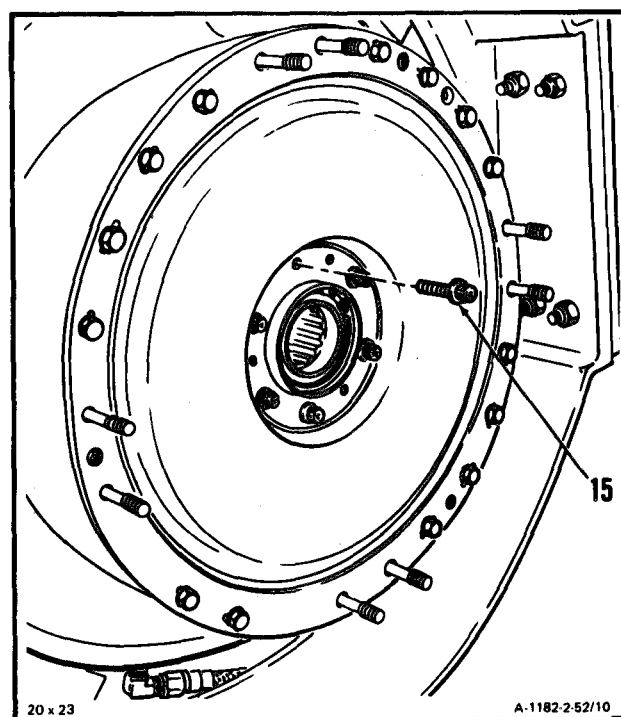
**INSPECT****GO TO NEXT PAGE**

2-52 INSTALL OUTPUT SHAFT SEAL AND HOUSING ASSEMBLY (Continued)

2-52

10. Check and set output shaft drift as follows:
- Push output shaft (1) rearward, and measure depth from shaft end (16) seal housing edge (17) using micrometer depth gage.
 - Pull output shaft (1) forward and repeat measurement in step a.
 - Subtract dimension in step b. from dimension in step a. Depth of drift shall be between 0.060 and 0.070 inch.
 - If needed to set drift, remove output shaft and seal housing (Ref. Task 2-48), and repeat steps 2. through 10. Lockwire bolts (15). Use lockwire (E29).

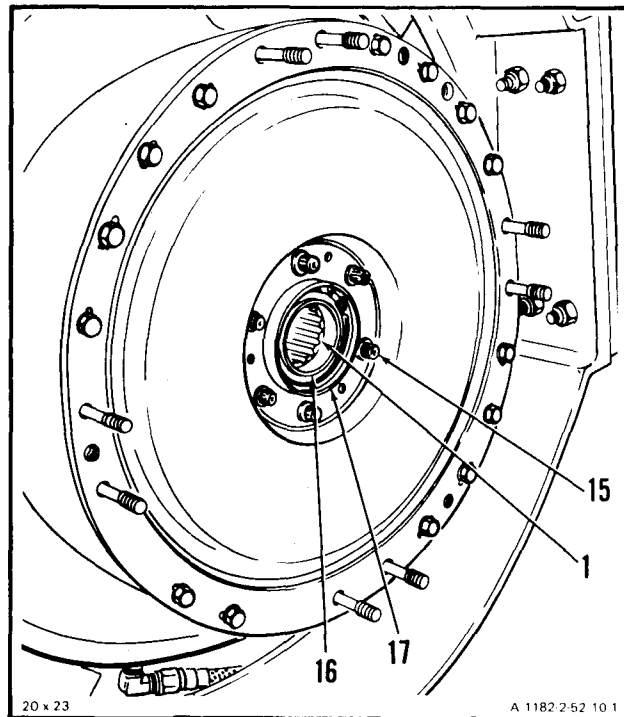
**FOLLOW-ON MAINTENANCE:**

Service Engine Oil System (Task 1-74).

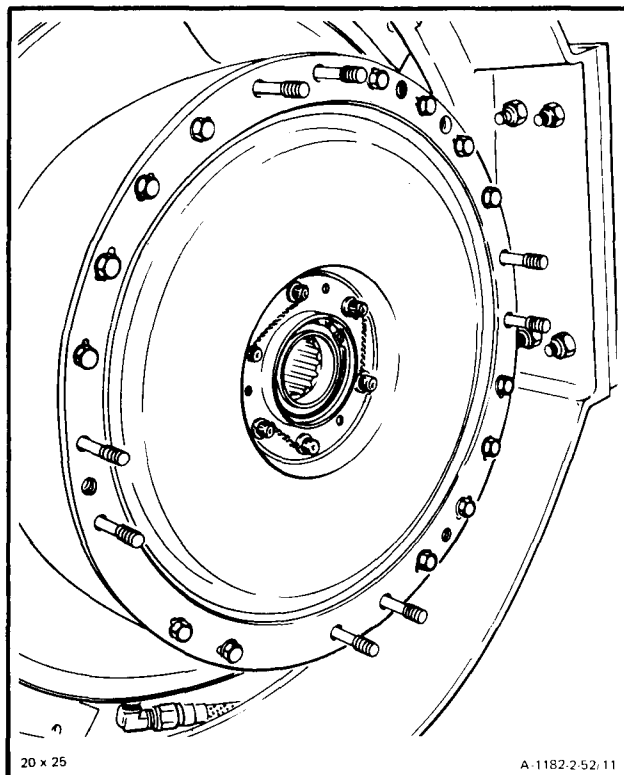
**END OF TASK**

Section X. INLET HOUSING COVER ASSEMBLY – MAINTENANCE PROCEDURES

2-53 REMOVE INLET HOUSING COVER ASSEMBLY

2-53

INITIAL SETUP

Applicable Configurations:

All

Tools:

- Powerplant Mechanics Tool Kit,
NSN 5180-00-323-4944
- Handling Tool (T16) or (T17) (3)

Materials/Parts:

- Wiping Rag (E64),

Personnel Required:

68B10 Aircraft Powerplant Repairer

Equipment Condition:

- Engine Oil System Drained (Task 1-75)
- Output Shaft Seal and Housing Removed
(Task 2-48)

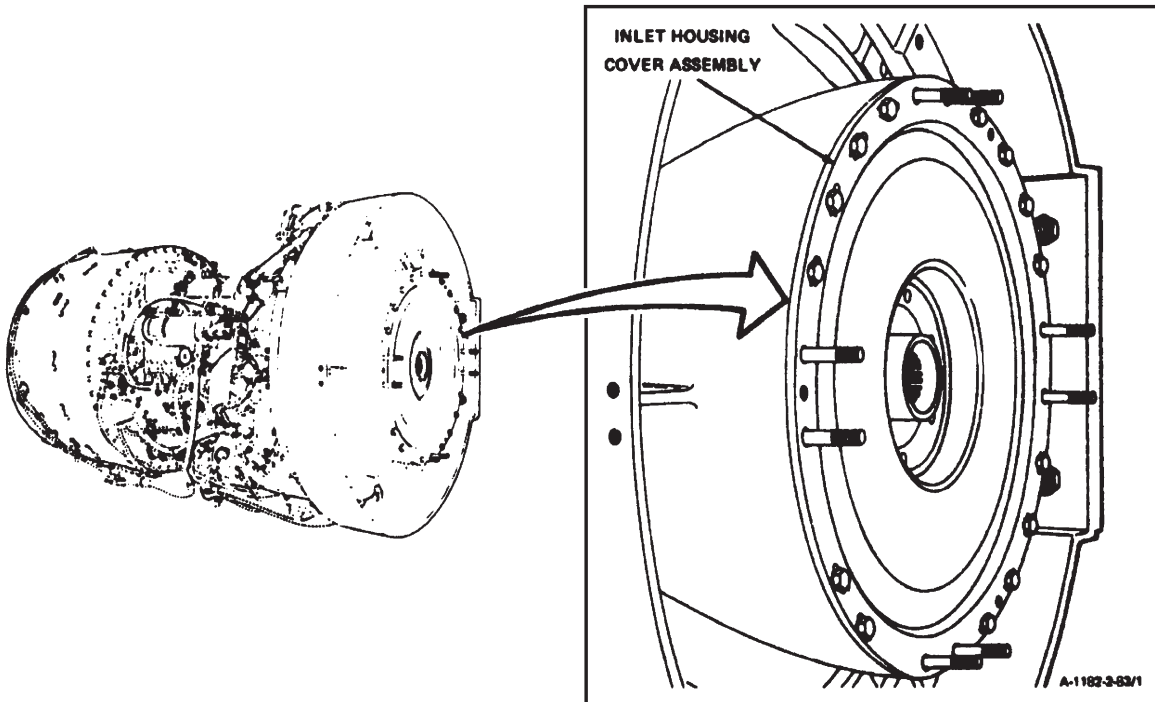

GO TO NEXT PAGE

1. Remove 14 bolts (1) and washers (2).

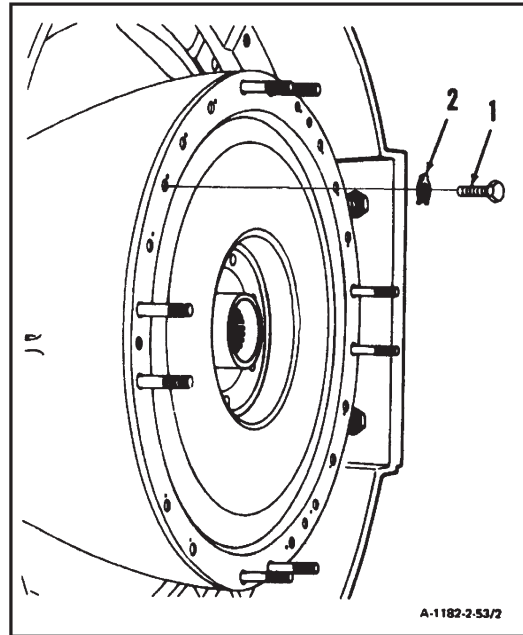

2. Install three handling tools (T16) or (T17) (3) in three threaded holes (4).

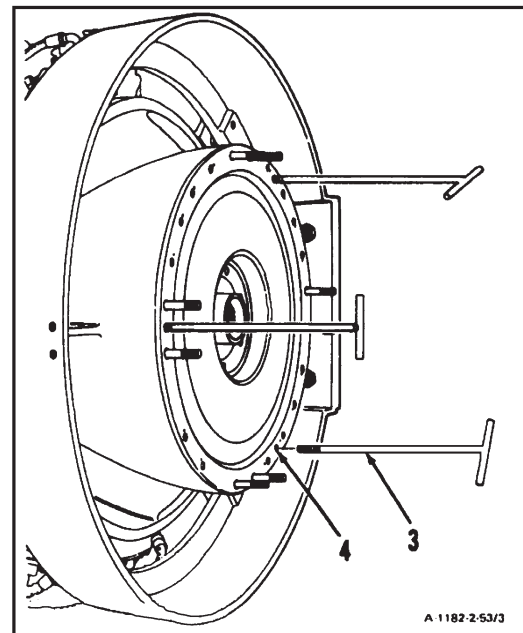

GO TO NEXT PAGE

2-53 REMOVE INLET HOUSING COVER ASSEMBLY (Continued)

2-53

3. Tighten three handling tools (T16) or (T17) (3) evenly until inlet housing cover assembly (5) separates from inlet housing (6). Remove cover assembly (5).
4. Remove two packings (7), and packing (8).

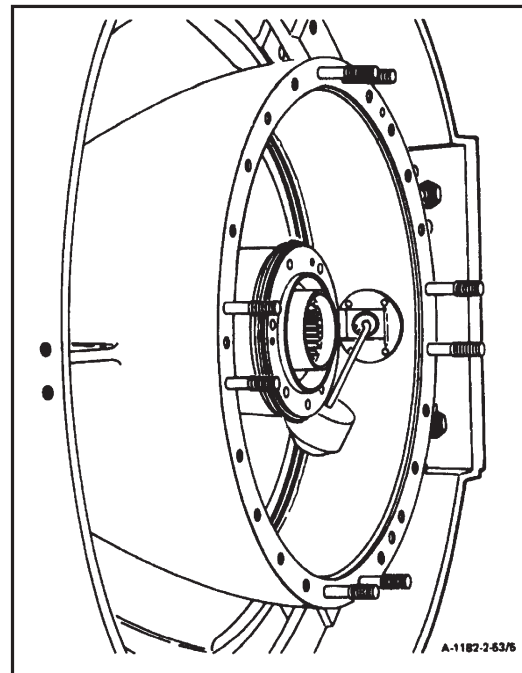
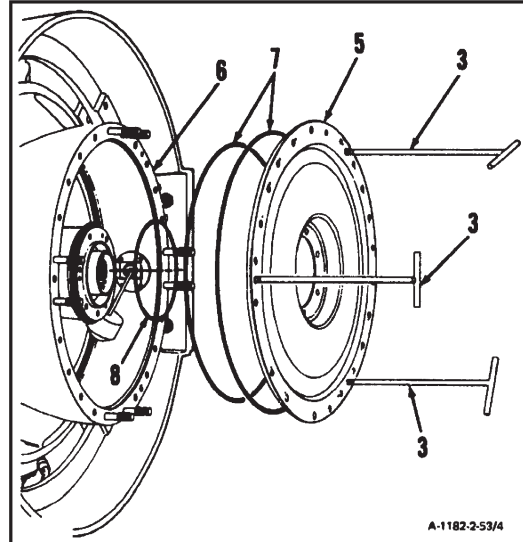

FOLLOW-ON MAINTENANCE:

None

END OF TASK

Change 7 2-457

INITIAL SETUP

Applicable Configurations:

All

Tools:

None

Materials/Parts:

Dry Cleaning Solvent (E17)

Gloves (E 20)

Lint Free cloth (E 26)

Personnel Required:

68B10 Aircraft Powerplant Repairer

Equipment Condition:

Off Engine Task

Engine Oil System Drained (Task 1-75)

**Output Shaft Seal and Housing Removed
(Task 2-48)**

**Inlet Housing Cover Assembly Removed
(Task 2-53)**

General Safety Instructions:

WARNING

Dry cleaning solvent (E17) is flammable and toxic. It can irritate skin and cause burns. Use only in well-ventilated area, away from heat and open flame. In case of contact, immediately flush skin or eyes with water for at least 15 minutes. Get medical attention for eyes.

1. **Wear gloves (E20). Clean inlet housing cover assembly (1).** Use lint-free cloth (E26) dampened in dry cleaning solvent (E17).
2. Wipe dry using clean, dry lint-free cloth (E26).

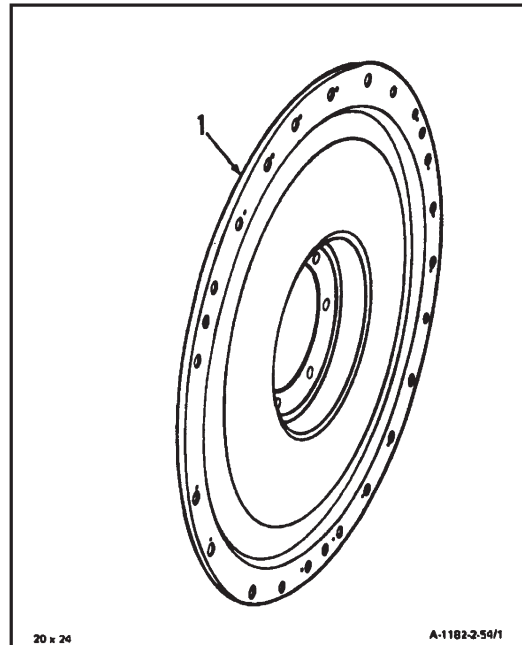

FOLLOW-ON MAINTENANCE

Inspect Inlet Housing Cover Assembly
(Task 2-55).

END OF TASK

2-55 REMOVE INLET HOUSING COVER ASSEMBLY

2-55

INITIAL SETUP**Applicable Configurations:**

All

Tools:Technical Inspection Tool Kit,
NSN 5180-00-323-5114**Materials/Parts:**

Fluorescent-Penetrant Materials (E19),

Personnel Required:

68B30 Aircraft Powerplant Inspector

References:

TM 1-1500-335-23

Equipment Condition:

Off Engine Task

1. Inspect inlet housing cover assembly (1).

- a. **Perform Fluorescent-penetrant inspection of cover Per Paragraph 2-12.1.e,** (Ref. TM 1-1500-335-23). There shall be no cracks.
- b. There shall be no nicks or scratches deeper than 0.030 inches.
- c. There shall be no corrosion or paint damage.

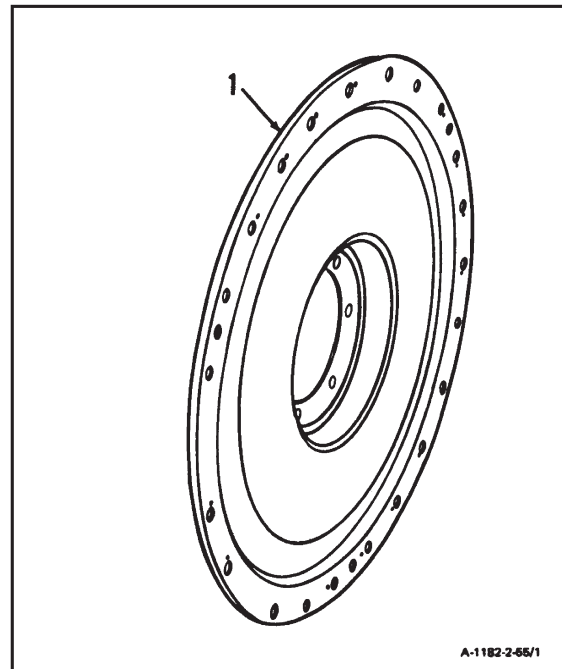
**FOLLOW-ON MAINTENANCE**

None

END OF TASK

2-56 REPAIR INLET HOUSING COVER ASSEMBLY (AVIM)

2-56

INITIAL SETUP

Applicable Configurations:

All

Tools:

Technical Inspection Tool Kit,
NSN 5180-00-323-5114

Materials:

Carborundum Stone (E10)
Crocus Cloth (E15)
Engine Gray Enamel (E22)

Personnel Required:

68B10 Aircraft Powerplant Repairer
68B30 Aircraft Powerplant Inspector

References:

Task 1-119

Equipment Condition:

Off Engine Task

1. **Repair nicks and scratches less than 0.030 inch deep** on inlet housing cover assembly (1) as follows:
 - a. **Blend all sharp edges** next to nicks and scratches. Use Carborundum stone (E10).
 - b. **Polish to smooth finish. Use** crocus cloth (E15).
2. **Repair damaged paint or corrosion** on inlet housing cover assembly (1). Use engine gray enamel (E22) (Ref. Task 1-119).

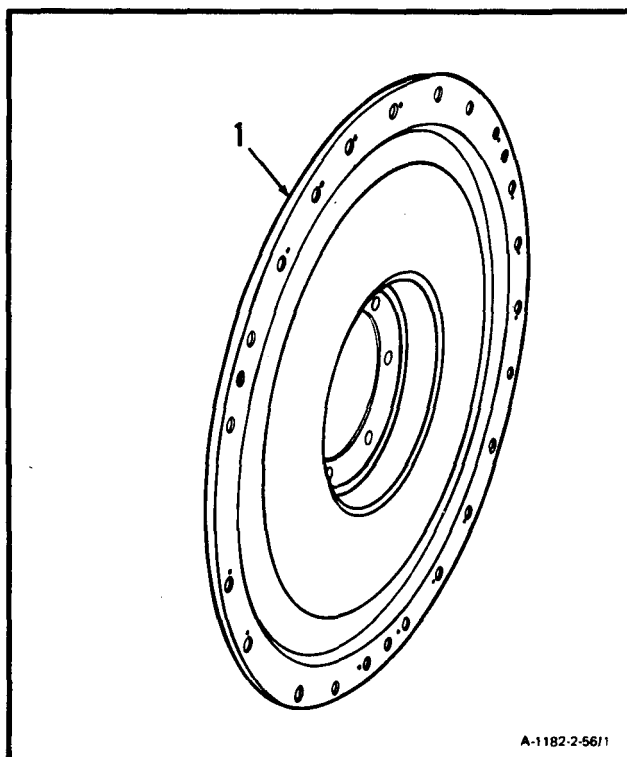

A-1182-2-56/1

INSPECT

FOLLOW-ON MAINTENANCE:

None

END OF TASK

2-57 INSTALL INLET HOUSING COVER ASSEMBLY

2-57

INITIAL SETUP

Applicable Configurations:

All

Tools:

Powerplant Mechanics Tool Kit,
NSN 5180-00-323-4944
Technical Inspection Tool Kit,
NSN 5180-00-323-5114

Materials:

None

Parts:

Packings

Personnel Required:

68B10 Aircraft Powerplant Repairer
68B30 Aircraft Powerplant Inspector

References:

TM 1-2840-254-23P

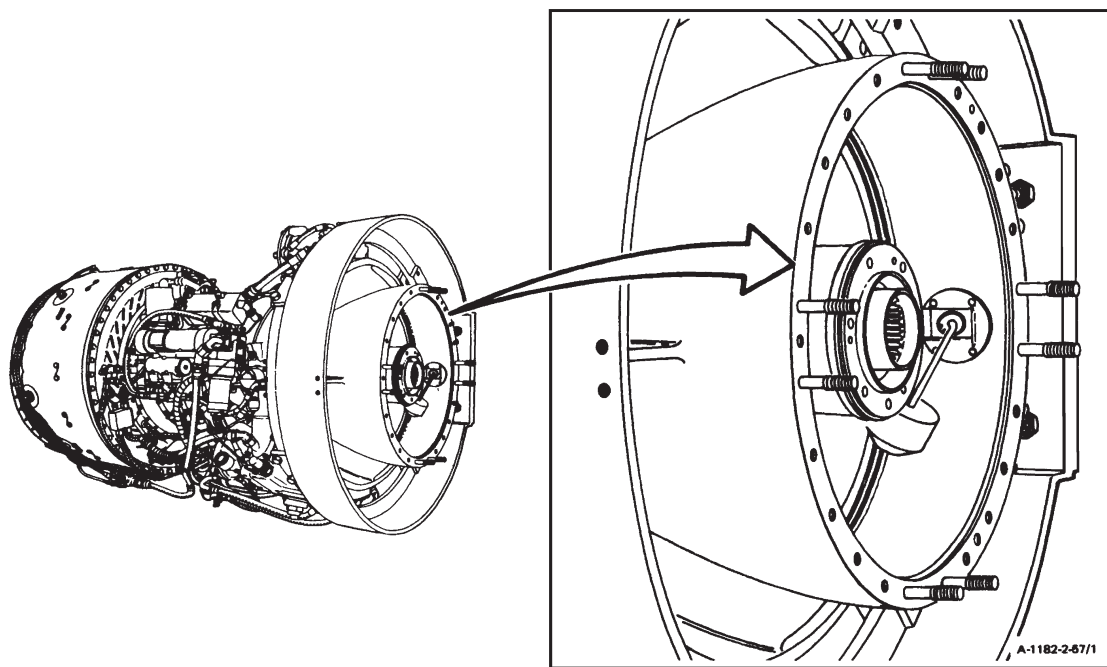

GO TO NEXT PAGE

2-57 INSTALL INLET HOUSING COVER ASSEMBLY (Continued)

1. **Install packing (1)** in groove (2) of inlet housing (3).
2. **Install packing (4)** in groove (5) of support housing (6).

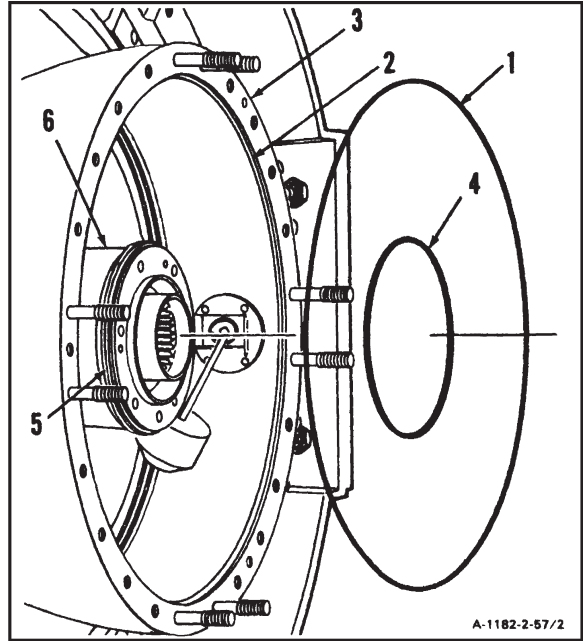

3. **Install packing (7)** on inlet housing cover assembly (8).

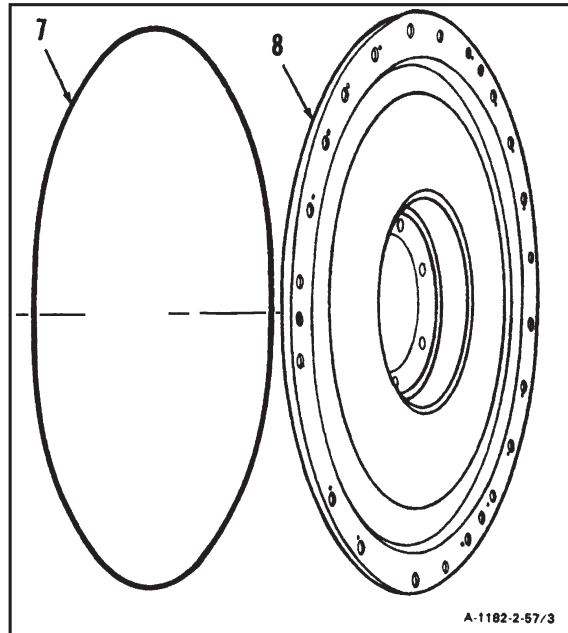

GO TO NEXT PAGE

2-57 INSTALL INLET HOUSING COVER ASSEMBLY (Continued)

2-57

4. **Install inlet housing cover assembly (8)** on inlet housing (3). Install 14 bolts (9) and washers (10).

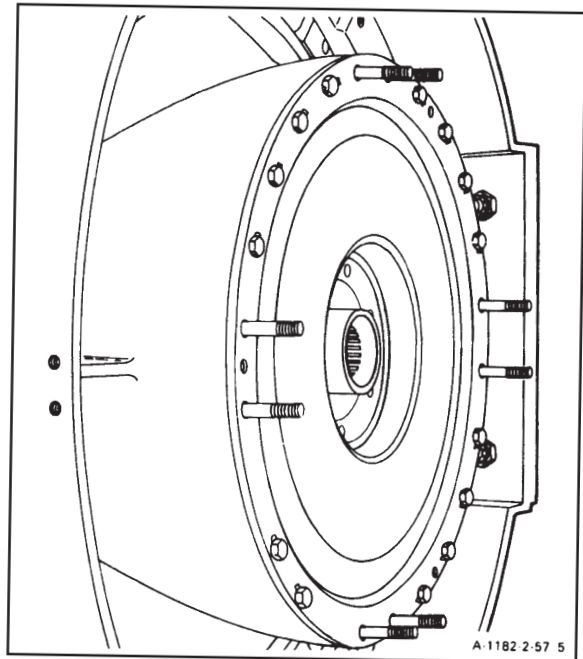
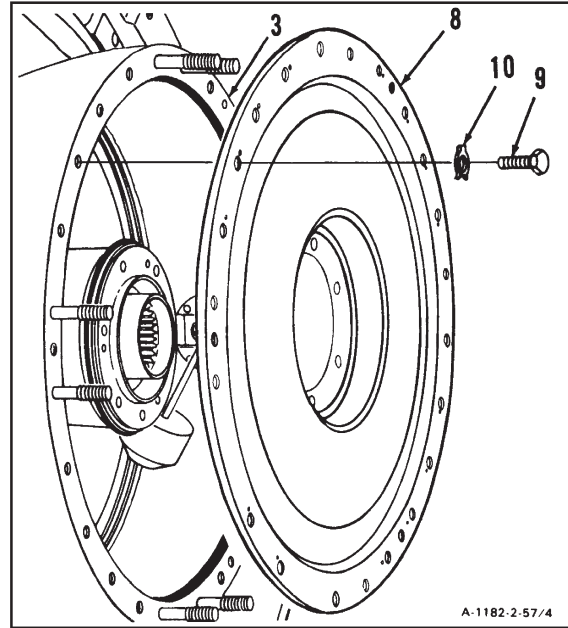

INSPECT

FOLLOW-ON MAINTENANCE

Install Output Shaft Seal and Housing Assembly
(Task 2-52)

Service Engine Oil System (Task 1-74)

END OF TASK

Section XI. OUTPUT SHAFT SUPPORT HOUSING – MAINTENANCE PROCEDURES

2-58 REMOVE OUTPUT SHAFT SUPPORT HOUSING

2-58

INITIAL SETUP

Applicable Configurations:
All

Tools:

- Powerplant Mechanics Tool Kit,
NSN 5180-00-323-4944
- Handling Tool (T18) (3)
- Aircraft Group Cover (T29)

Materials/Parts:

- Wiping rag (E58)

Personnel Required:

- 68B10 Aircraft Powerplant Repairer

Equipment Condition:

- Engine Oil System Drained (Task 1-75)
- Output Shaft Seal and Housing Removed
(Task 2-48)
- Inlet Housing Cover Assembly Removed
(Task 2-53)

Overspeed Drive and Outlet Cover Assembly
Removed (Task 5-17)
Output Shaft Removed (Task 9-6)

WARNING

Lubricating oils (E32 and E33) cause paralysis if swallowed. Prolonged contact with them may irritate the skin. Handle only in well-ventilated areas away from heat and flame. Drain and store in approved metal containers. Avoid prolonged or repeated contact with skin and do not take internally. Wash contacted areas of skin thoroughly after handling. If irritation of skin results, get medical attention. Get medical attention for eyes.

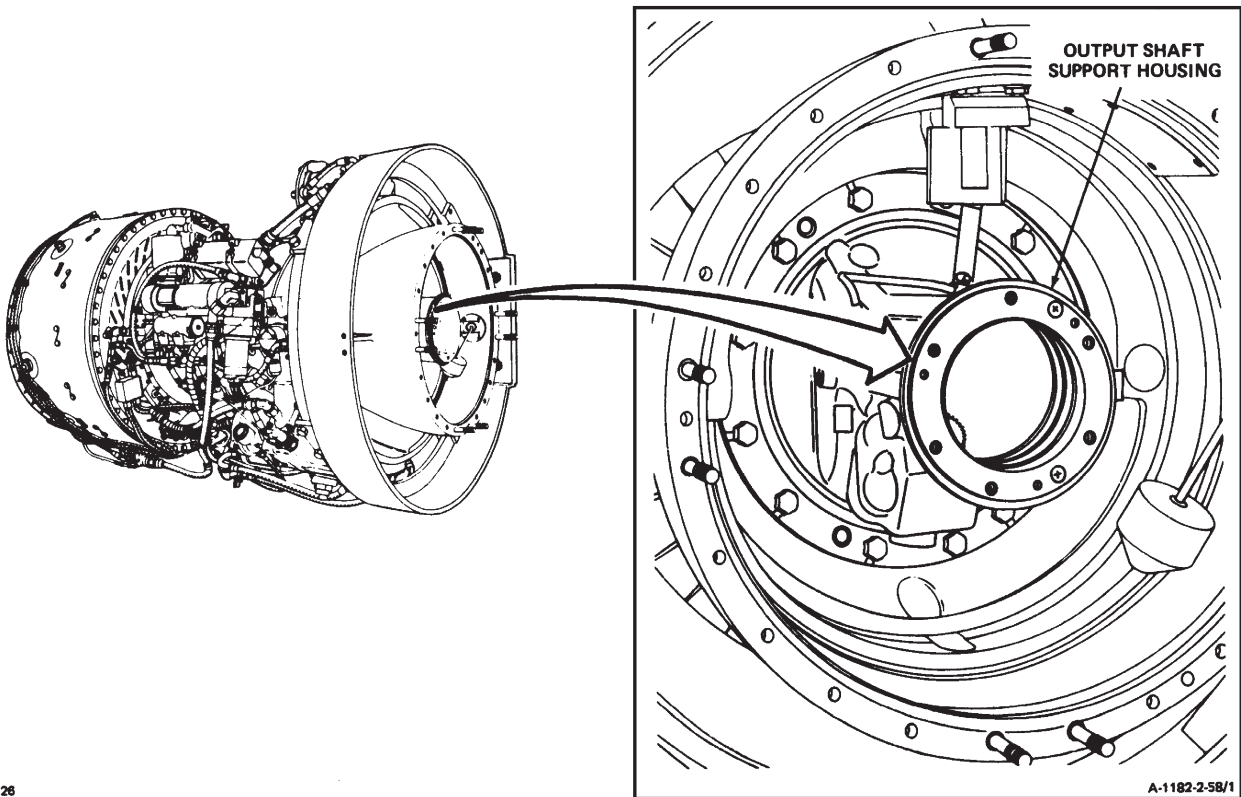

42 X 26
GO TO NEXT PAGE

2-58 REMOVE OUTPUT SHAFT SUPPORT HOUSING (Continued)

2-58

1. Straighten tabs of 12 key washers (1). Remove 12 bolts (2) and key washers (1).

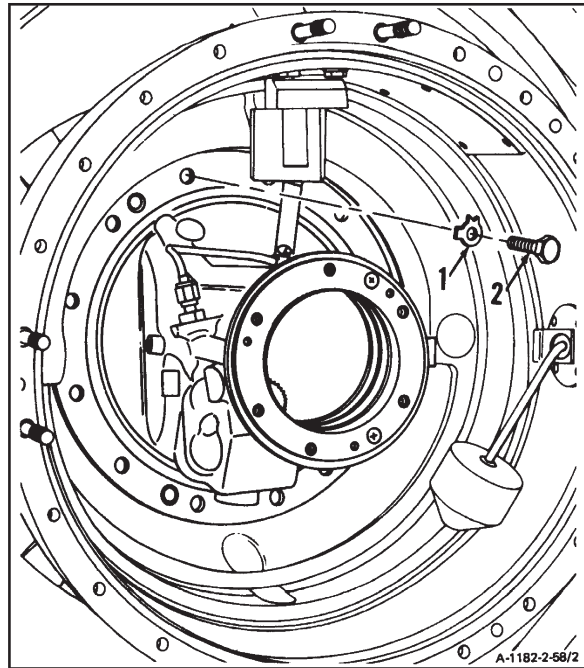

2. Install three handling tools (T18) (3) in threaded holes (4) on output shaft support housing (5).

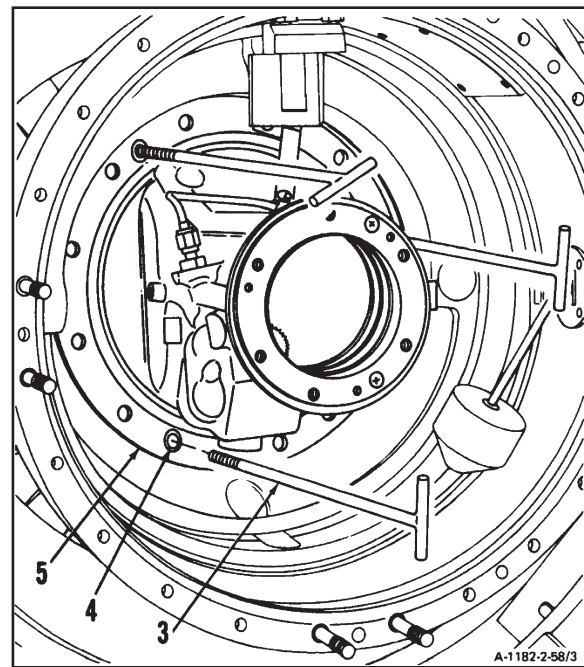

GO TO NEXT PAGE

2-58 REMOVE OUTPUT SHAFT SUPPORT HOUSING (Continued)

2-58

3. Using three handling tools (T18) (3), jack output shaft support housing (5) from inlet housing assembly (6).
4. **Remove output shaft support housing (5).** Remove three handling tools (T18) (3).

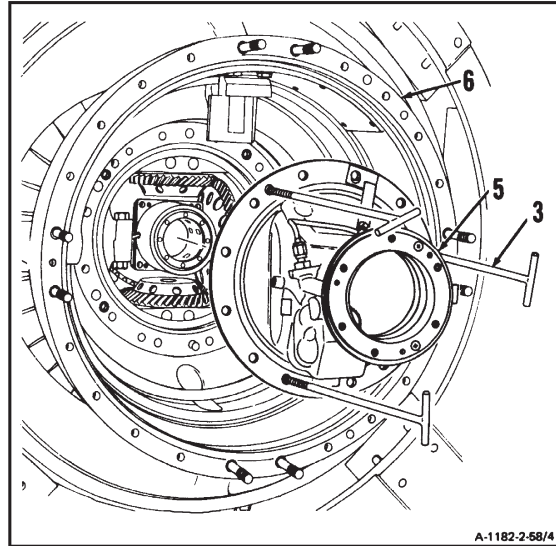

5. Remove packing (7).

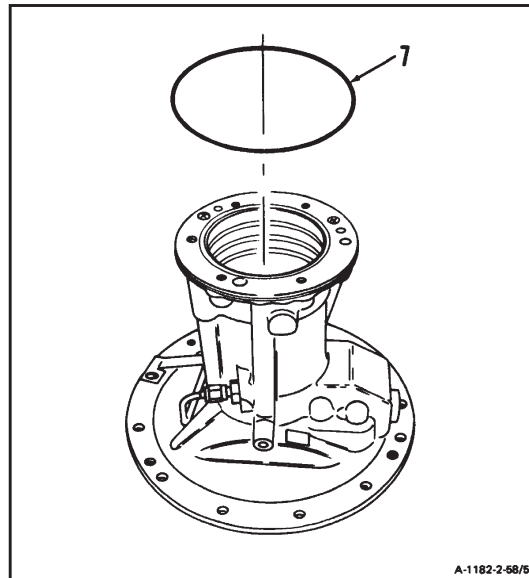
**GO TO NEXT PAGE**

6. Remove two packings (8 and 9).

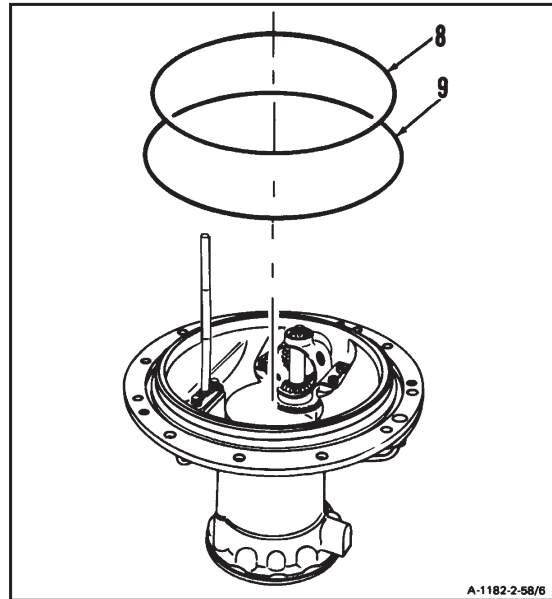

7. Install aircraft group cover (T29) (10) on aft end of output shaft support housing (5).

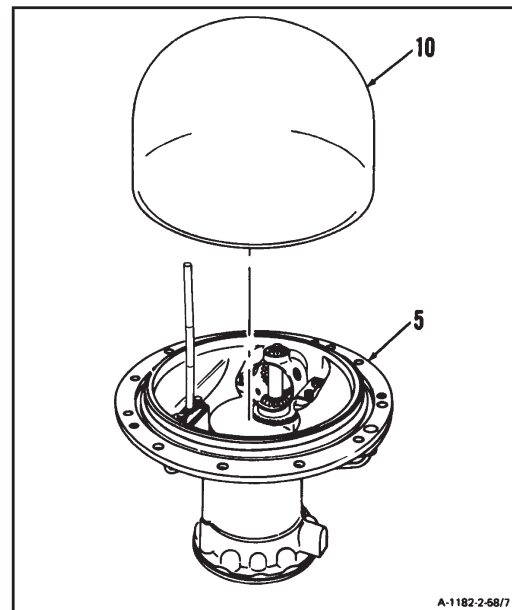

GO TO NEXT PAGE

2-58 REMOVE OUTPUT SHAFT SUPPORT HOUSING (Continued)

2-58

NOTE

In following step, remove transfer tube either from inlet housing, as shown, or from rear of output shaft support housing.

8. **Remove transfer tube (11) and two packings (12).**

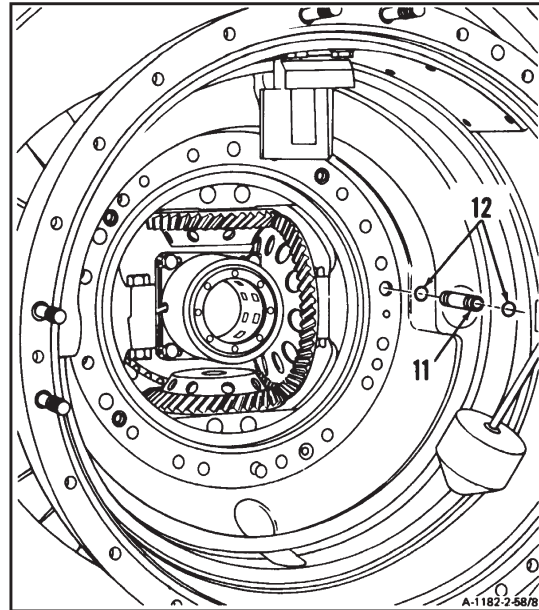
**FOLLOW-ON MAINTENANCE:**

None

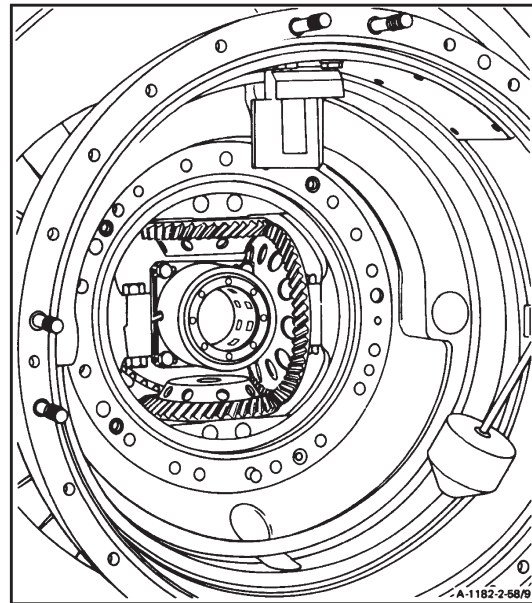
**END OF TASK**

INITIAL SETUP

Applicable Configurations:

All

Tools:

Powerplant Mechanic's Tool Kit,
NSN 5180-00-323-4944
Handling Tool (T16)

Materials:

None

Personnel Required:

68B10 Aircraft Powerplant Repairer

Equipment Condition:

Off Engine Task
Engine Oil System Drained (Task 1-75)
Output Shaft Seal and Housing Removed
(Task 2-48)
Inlet Housing Cover Assembly Removed
(Task 2-53)
Overspeed Drive and Outlet Cover Assembly
Removed (Task 5-17)
Output Shaft Removed (Task 9-6)
Output Shaft Support Housing Removed
(Task 2-58)

-
1. Remove aircraft group cover (T29) (1) from output shaft support housing (2).

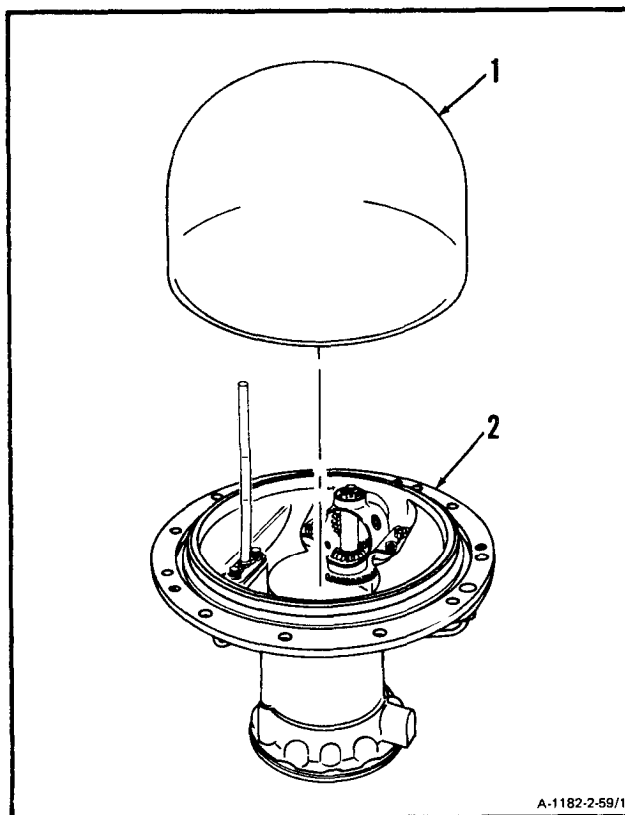

GO TO NEXT PAGE

2. Remove lockwire, two bolts (3), and bearing lube tube assembly (4).

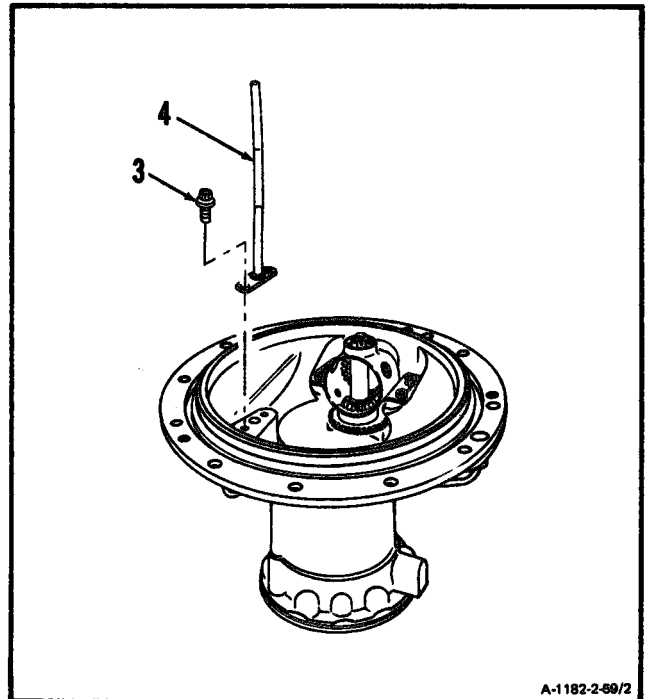

NOTE

In following step, remove oil filter element either from output shaft support housing, as shown, or from bearing lube tube assembly.

3. Remove oil filter element (5) and packing (6).

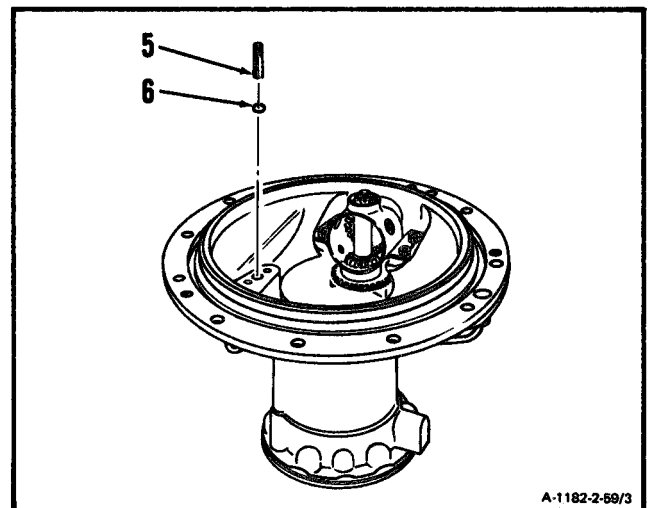

GO TO NEXT PAGE

4. Remove lockwire and four bolts (7).

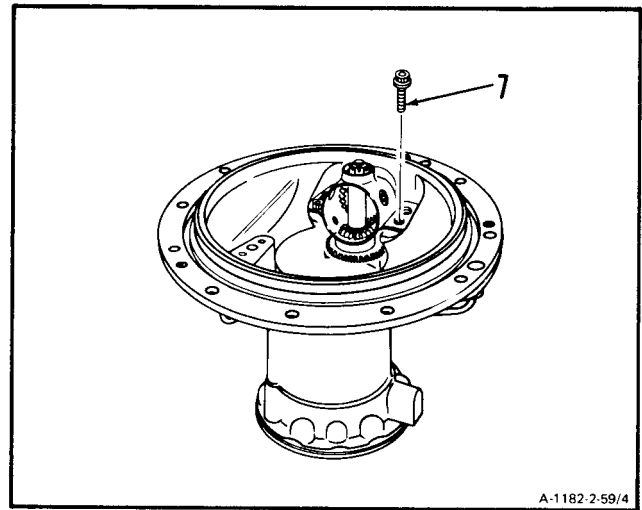

5. Remove overspeed gear assembly (8).

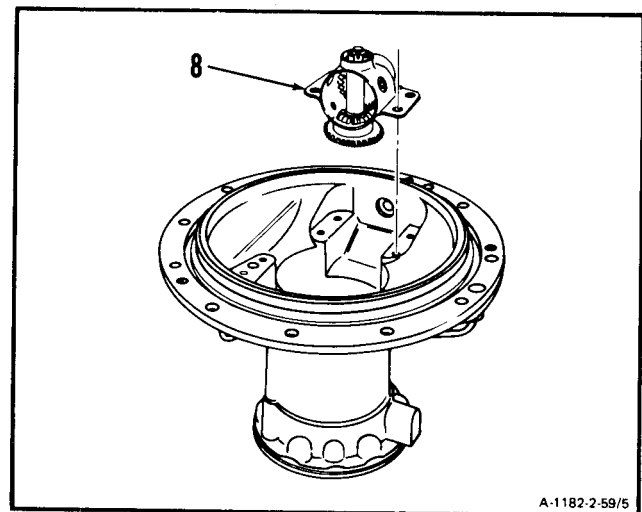

GO TO NEXT PAGE

6. Remove two screws (9).

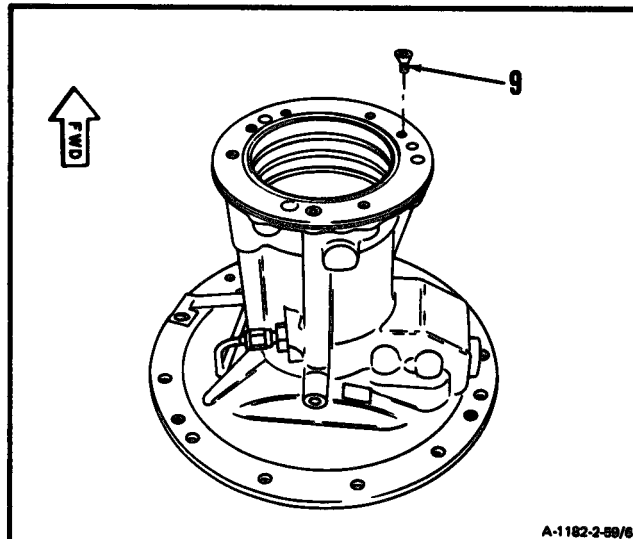

7. Install three handling tools (T16) (10) in threaded holes (11) on bearing housing liner (12).

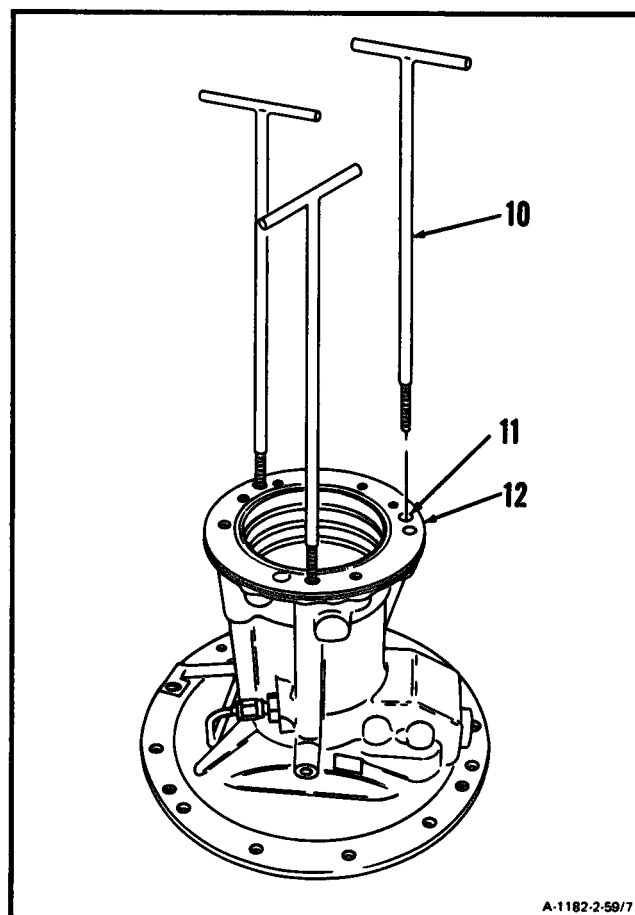

GO TO NEXT PAGE

8. Using three handling tools (T16) (10), jack bearing housing liner (12) from housing assembly (13).
9. **Remove bearing housing liner (12), packing (14), and two packings (15).** Remove three handling tools (T16) (10).

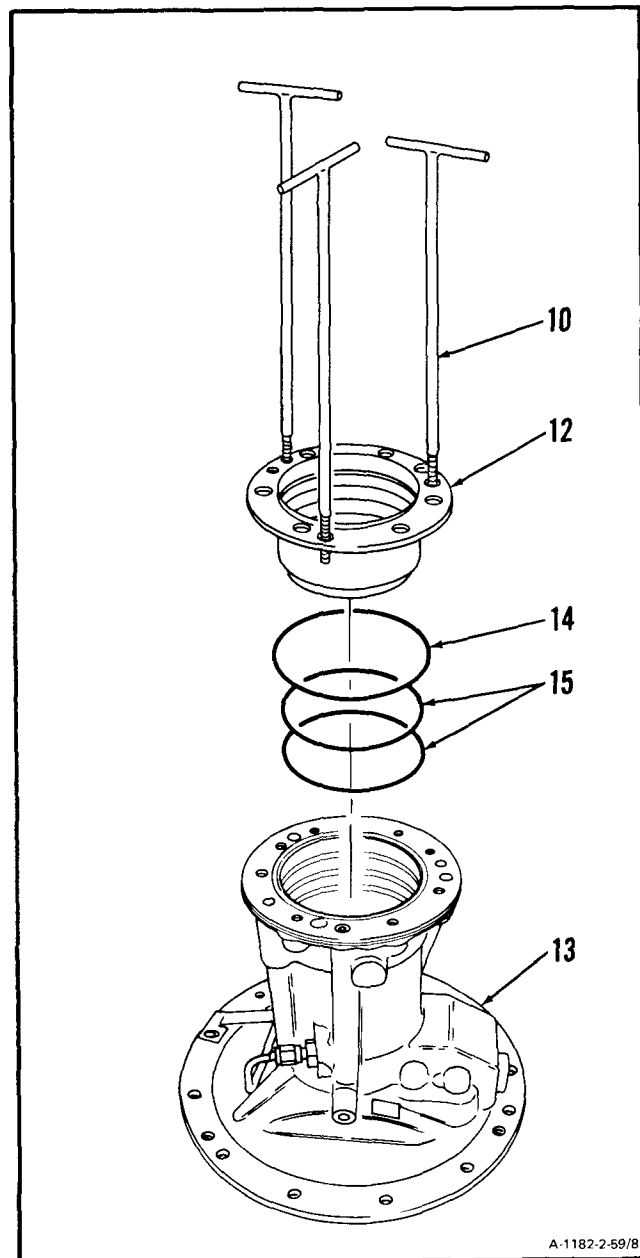

GO TO NEXT PAGE

2-59 DISASSEMBLE OUTPUT SHAFT SUPPORT HOUSING (AVIM) (Continued)

2-59

10. Install handling tool (T16) (10) in oil filter element (16).

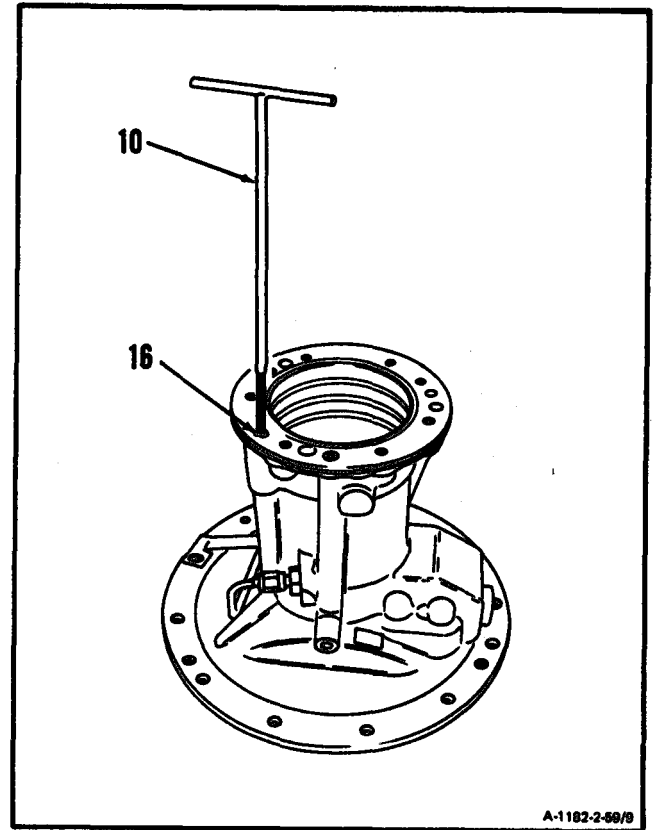

GO TO NEXT PAGE

11. Using handling tool (T16) (10), **remove oil filter element (16)** and packing (17). Remove handling tool (T16) (10).

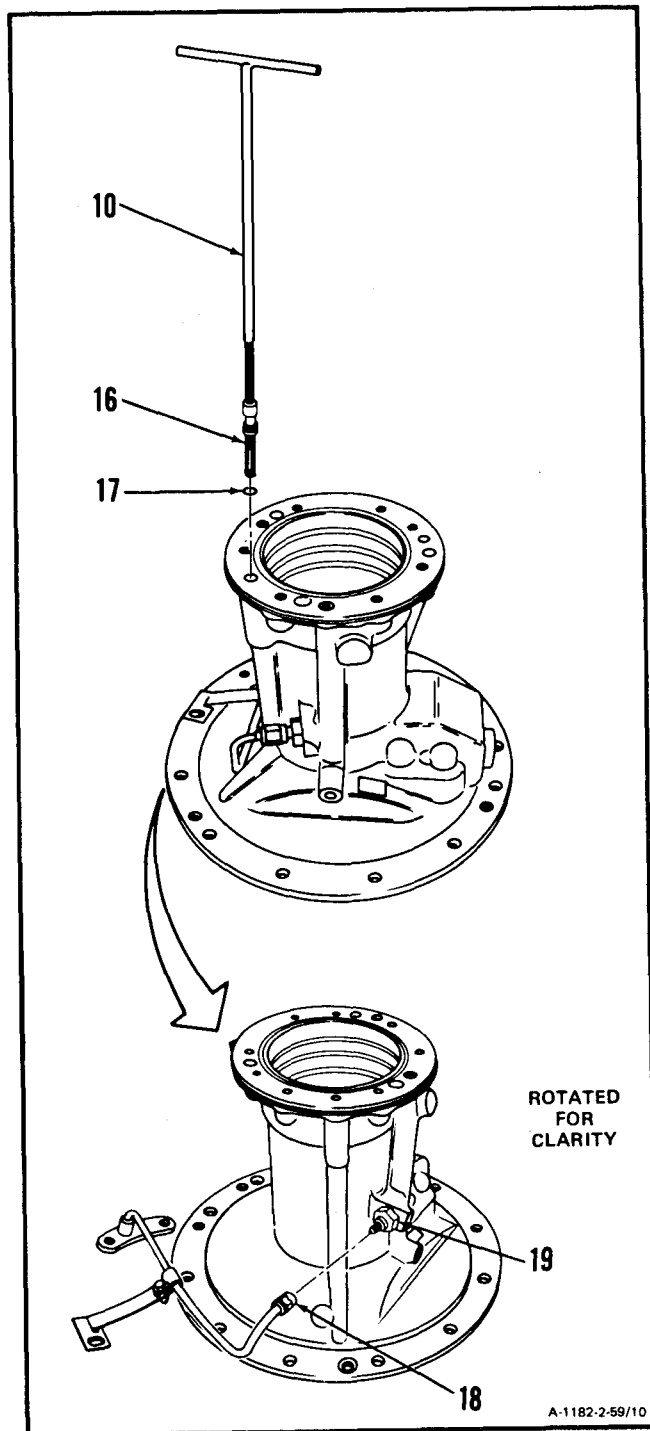

12. **Remove tube assembly (18)** from nipple (19).

GO TO NEXT PAGE

2-59 DISASSEMBLE OUTPUT SHAFT SUPPORT HOUSING (AVIM) (Continued)

2-59

13. Remove nipple (19) and packing (20).

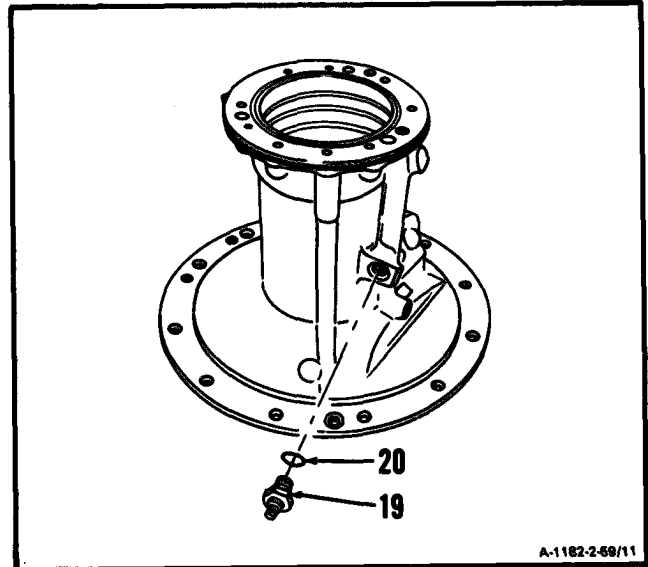

FOLLOW-ON MAINTENANCE:

None

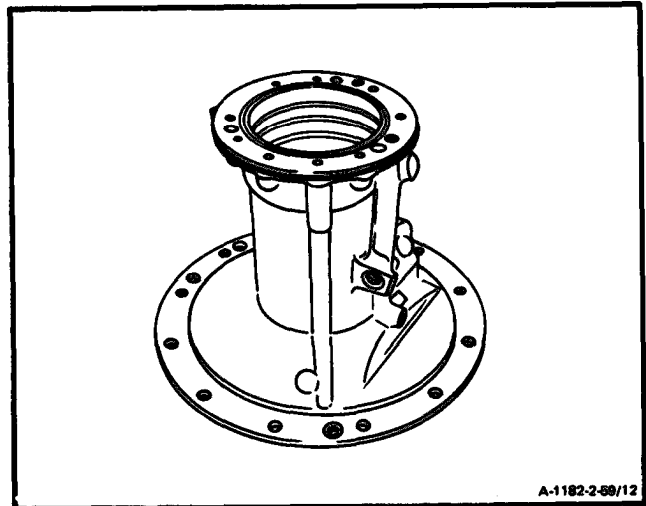

END OF TASK

2-477

INITIAL SETUP

Applicable Configurations:

All

Tools:Powerplant Mechanic's Tool Kit,
NSN 5180-00-323-4944

Goggles

Compressed Air Source

Materials:

Dry Cleaning Solvent (E17)

Gloves (E20)

Personnel Required:

68B10 Aircraft Powerplant Repairer

Equipment Condition:

Off Engine Task

Engine Oil System Drained (Task 1-75)

Output Shaft Seal and Housing Assembly
Removed (Task 2-48)Inlet Housing Cover Assembly Removed
(Task 2-53)Overspeed Drive and Outlet Cover Assembly
Removed (Task 5-17)

Output Shaft Removed (Task 9-6)

Output Shaft Support Housing Removed
(Task 2-58)Output Shaft Support Housing Disassembled
(Task 2-59)**General Safety Instructions:****WARNING**

Dry cleaning solvent (E17) is flammable and toxic. It can irritate skin and cause burns. Use only in well-ventilated area, away from heat and open flame. In case of contact, immediately flush skin or eyes with water for at least 15 minutes. Get medical attention for eyes.

WARNING

When using compressed air for cleaning, use approved protective equipment for eyes and face. Do not use more than 30 psig air pressure. Do not direct air toward yourself or another person. Failure to comply could result in injury to eyes or skin. In case of injury, get medical attention.

1. Clean oil filter element (1), bearing lube tube assembly (2) and transfer tube (3) as follows:

- a. Wear gloves (E20). Immerse oil filter element (1), bearing lube tube assembly (2) and transfer tube (3) in dry cleaning solvent (E17) and agitate. Use brush on inner surfaces.
- b. Wear goggles. **Blow dry parts.** Use clean, dry, compressed air.

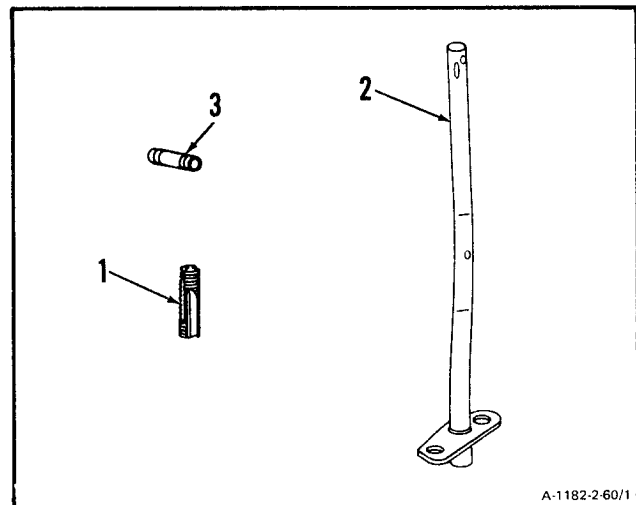

A-1182-2-60/1

GO TO NEXT PAGE

2. Clean oil filter element (4) and housing assembly (5) as follows:

- a. Immerse oil filter element (4) in dry cleaning solvent (E17) and agitate. Use brush on inner surfaces.
- b. Clean housing assembly (5) with dry cleaning solvent (E17). Use brush on inner surfaces.
- c. Blow dry parts. Use clean, dry compressed air.

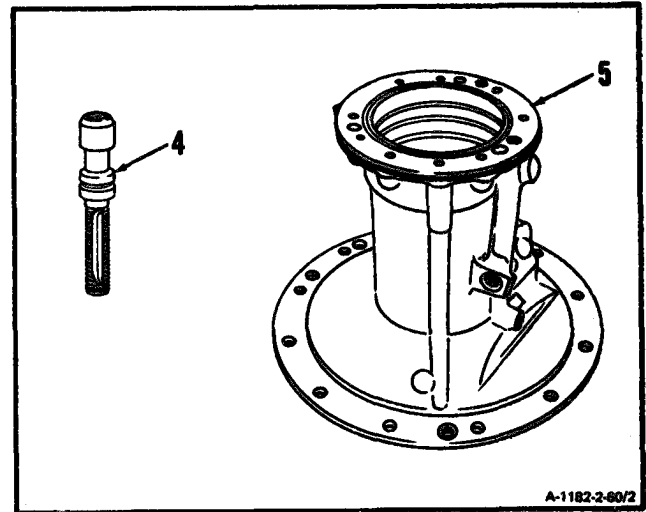

3. Clean bearing housing liner (6) and overspeed gear assembly (7) as follows:

- a. Clean bearing housing liner (6) and overspeed gear assembly (7) with dry cleaning solvent (E17). Use brush on inner surfaces.
- b. Blow dry parts. Use clean, dry compressed air.

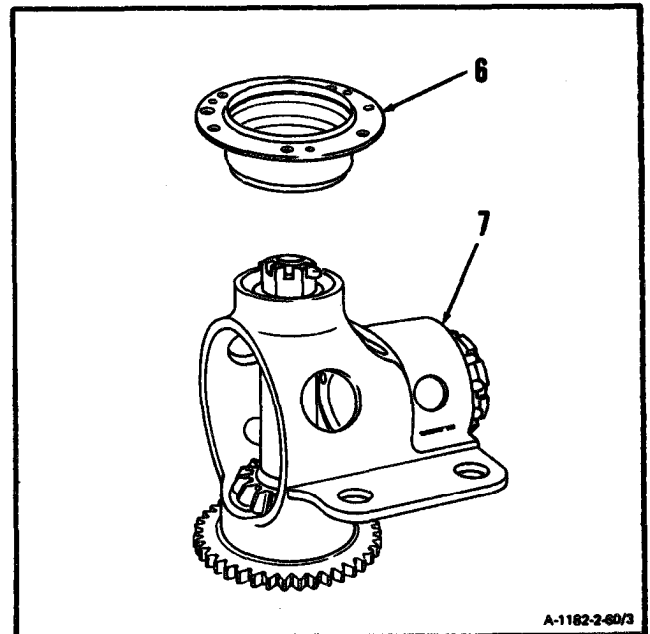

GO TO NEXT PAGE

4. Clean tube assembly (8) and bracket (9) as follows:

- a. Immerse tube assembly (8) and bracket (9) in dry cleaning solvent (E17) and agitate. Use brush on inner surfaces.
- b. Blow dry tube assembly (8) and bracket (9). Use clean, dry, compressed air.

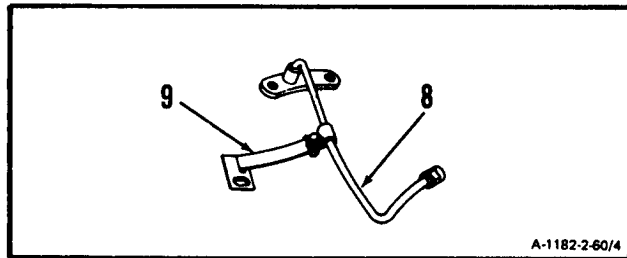

FOLLOW-ON MAINTENANCE:

Inspect Output Shaft Support Housing
(Task 2-61).

END OF TASK

2-61 INSPECT OUTPUT SHAFT SUPPORT HOUSING (AVIM)

2-61

INITIAL SETUP**Applicable Configurations:**

All

Tools:Technical Inspection Tool Kit,
NSN 5180-00-323-5114**Materials:**

Lockwire (E29)

Personnel Required:

68B30 Aircraft Powerplant Inspector

References:

Task 1-118

Equipment Condition:

Off Engine Task

1. **Inspect oil filter element (1), bearing lube tube assembly (2), and oil filter element (3).** There shall be no clogging or contamination. Check oil spray holes (4) for blockage. Use short piece of lockwire (E29).

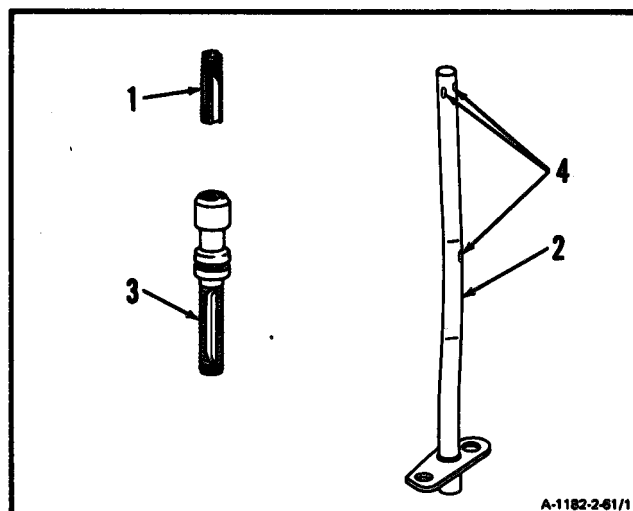
**GO TO NEXT PAGE**

2. **Inspect housing assembly (5) and bearing housing liner (6).** There shall be no cracks.

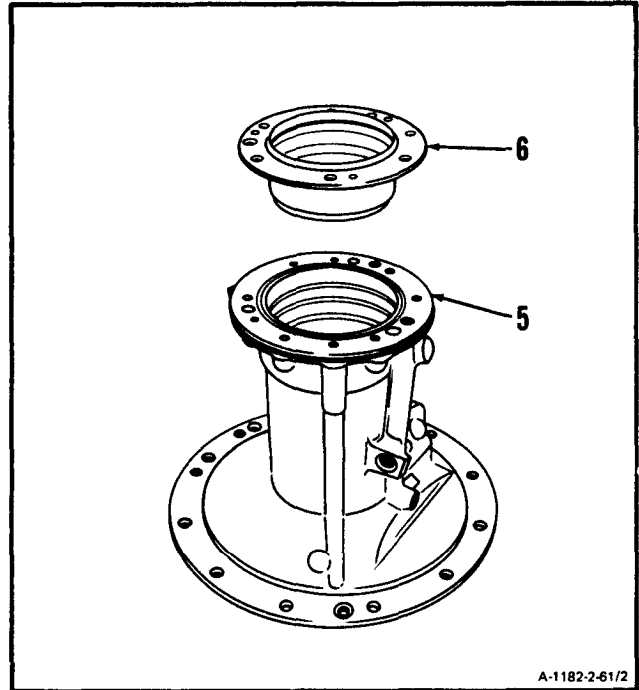

3. **Inspect overspeed gear assembly (7)** for gear pattern. There shall be no improper gear pattern. **Clean, inspect, and repair splines and gears** (Ref. Task 1-118).

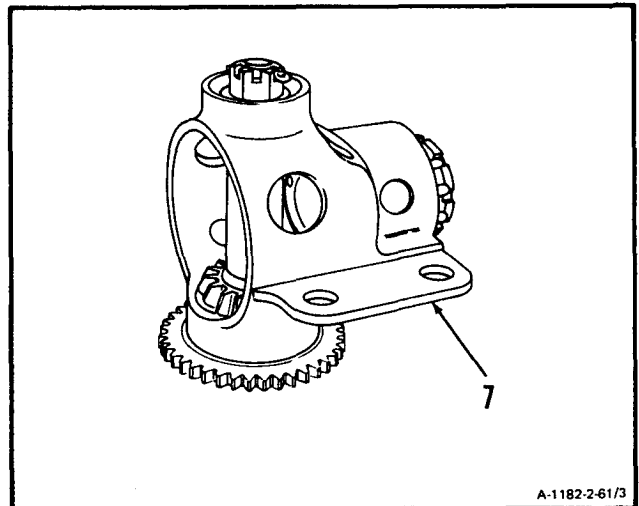

4. **Inspect tube assembly (8), bracket (9), and transfer tube (10).** There shall be no cracks. There shall be no clogging or contamination of tube assembly (8) or transfer tube (10).

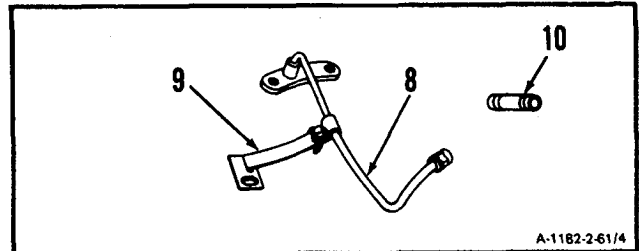

FOLLOW-ON MAINTENANCE:

None

END OF TASK

2-62 ASSEMBLE OUTPUT SHAFT SUPPORT HOUSING (AVIM)**2-62**

INITIAL SETUP**Parts:****Applicable Configurations:**

All

Packings

Tools:

Powerplant Mechanic's Tool Kit,
NSN 5180-00-323-4944
Technical Inspection Tool Kit,
NSN 5180-00-323-5114
Aircraft Group Cover (T29)
Rubber Mallet
Insertion Tools (E36 and E37)

Personnel Required:

68B30 Aircraft Powerplant Repairer
68B30 Aircraft Powerplant Inspector

References:

TM 55-2840-254-23P

Materials:

Lockwire (E29)

Equipment Condition:Off Engine Task

1. **Install** packing (1) and **nipple (2)** in housing assembly (3).

GO TO NEXT PAGE**Change 6 2-483**

CAUTION

Seal must be dipped in lubricating oil before installation. Failure to comply will cause damage to seal.

1. **Install seals (3.1 and 3.2) in housing (3).**
 - a. Using the insertion tools (E36) and an arbor press, press two seals (3.1 and 3.2) into the housing.
 - b. Dip top seal (3.1) in lubrication oil (E32 or E33).
 - c. Install top seal (3.1) **with lip up in housing (3)** using top seal installation tool (E36) and arbor press.
 - d. Dip bottom seal (3.2) in lubricating oil (E32 or E33).
 - e. Install bottom seal (3.2) with **lip down in housing (3)** using bottom seal installation tool (E36) and arbor press.

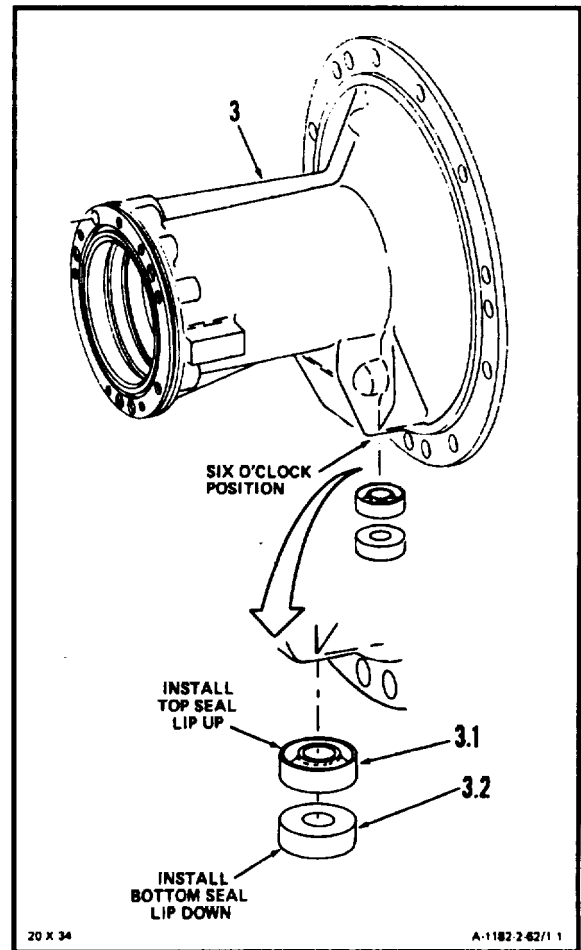

GO TO NEXT PAGE

2-484 Change 6

2. Align hole (4) with hole (5) and **install tube assembly (6)** on nipple (2).

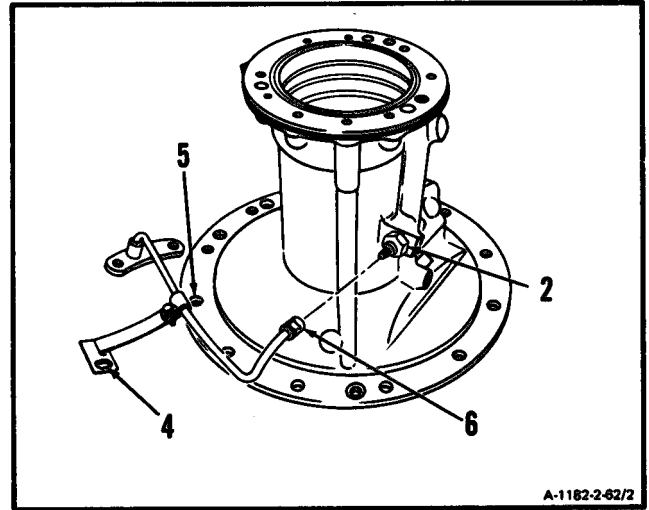

3. **Install** packing (7) in groove (8) in oil filter element (9) and install **oil filter element (9)** in housing assembly (3). Use rubber mallet.

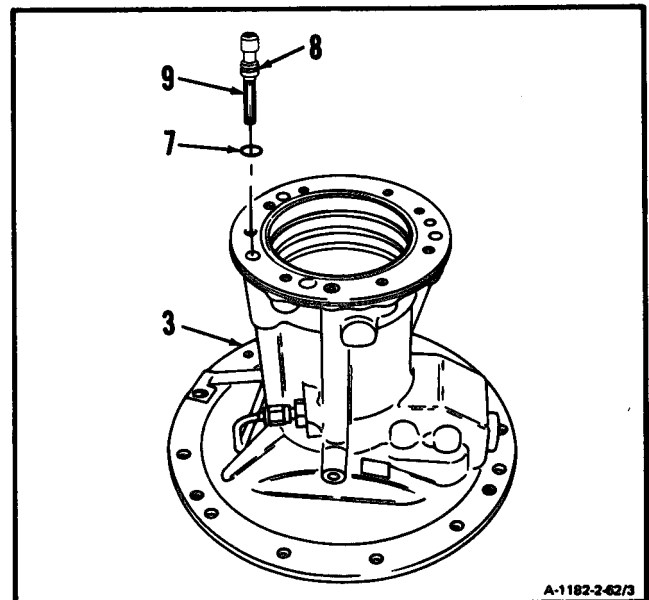

GO TO NEXT PAGE

4. **Install** two packings (10), packing (11), and **bearing housing liner (12)** in housing assembly (3).
Use rubber mallet.

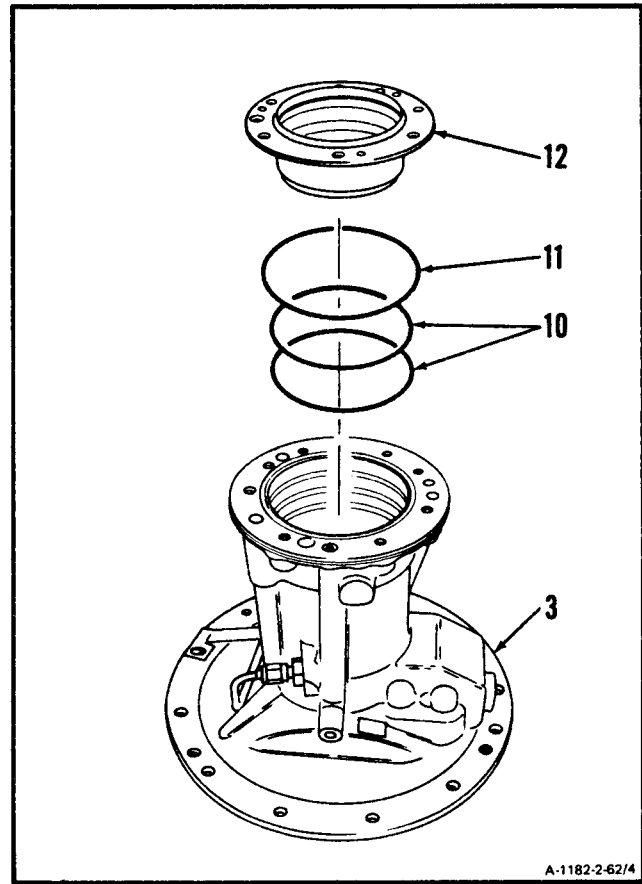

5. Install two screws (13).

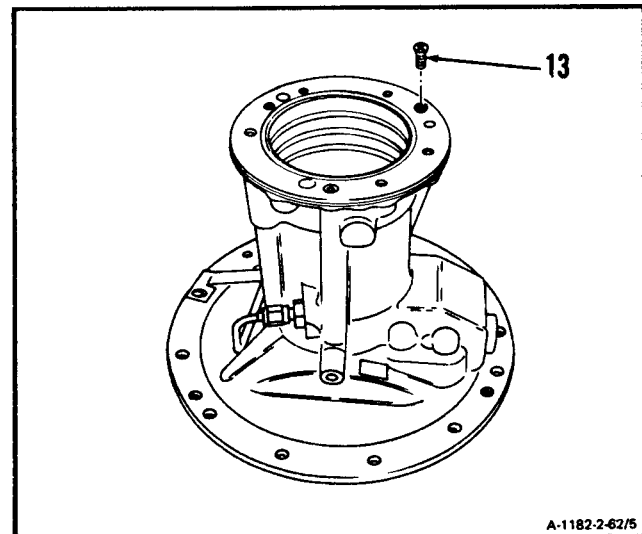

GO TO NEXT PAGE

6. Install **overspeed gear assembly (14)** in housing assembly (3).

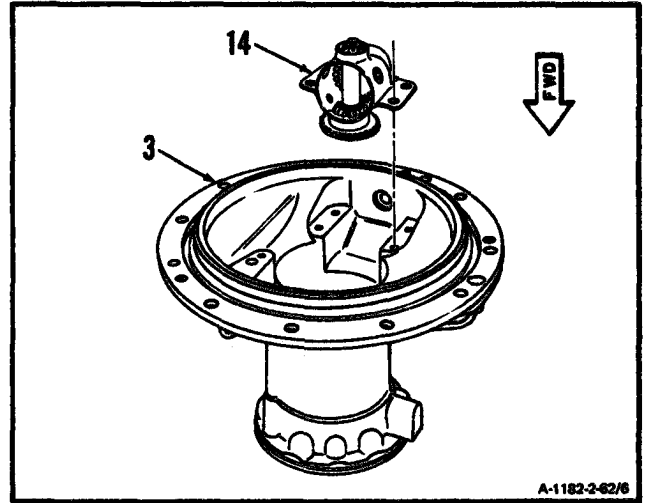

7. Install four bolts (15). Lockwire bolts (15). Use lockwire (E29).

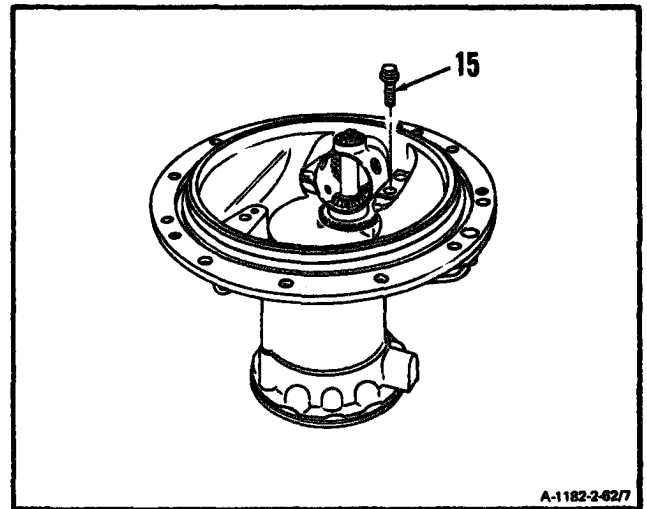

GO TO NEXT PAGE

8. Install packing (16) in groove (17) in housing assembly (3). Install oil filter element (18) in bearing lube tube assembly (19) until shoulder (20) seats against tube end (21). **Install bearing lube tube assembly (19)** in housing assembly (3).

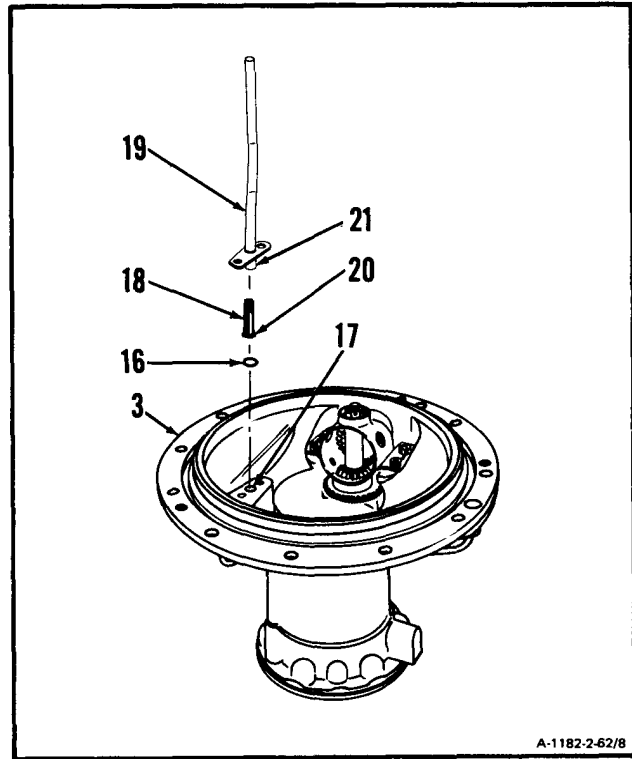

9. Install two bolts (22). Lockwire bolts (22). Use lockwire (E29).

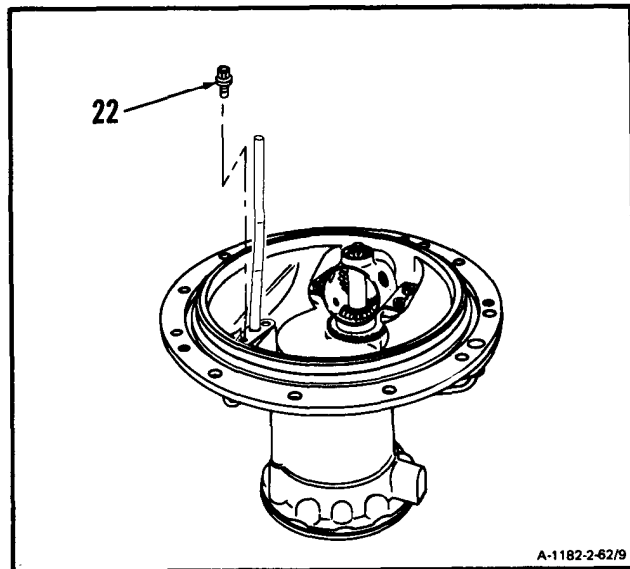

GO TO NEXT PAGE

10. Install aircraft group cover (T29) (23) on aft end of output shaft support housing (24).

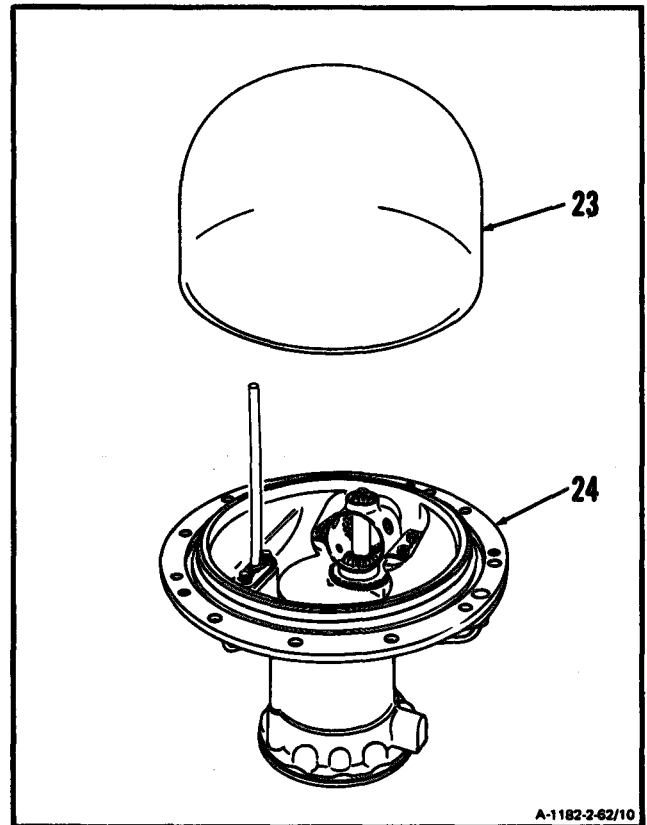

INSPECT

FOLLOW-ON MAINTENANCE:

None

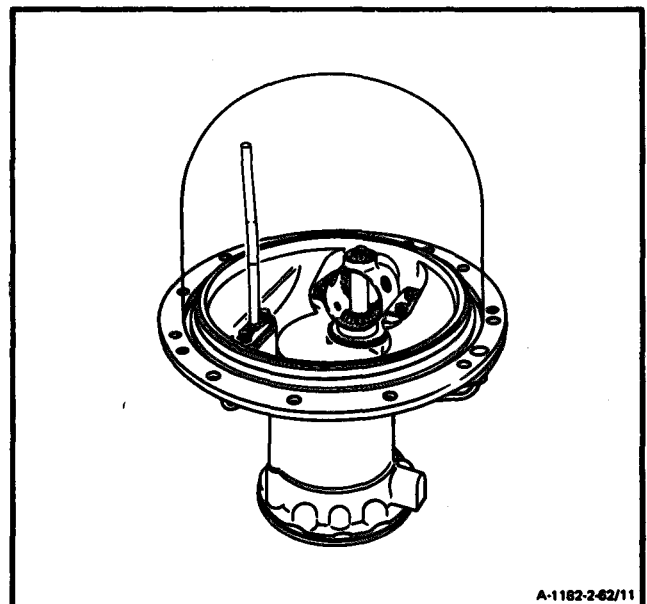

END OF TASK

INITIAL SETUP

Applicable Configurations:

All

Tools:

Powerplant Mechanic's Tool Kit,
NSN 5180-00-323-4994
Technical Inspection Tool Kit,
NSN 5180-00-323-5114

Materials:

Marking Pencil (E34)

Parts:

Packings
Key Washers

Personnel Required:

68B10 Aircraft Powerplant Repairer
68B30 Aircraft Powerplant Inspector

References:

TM 1-2840-254-23P

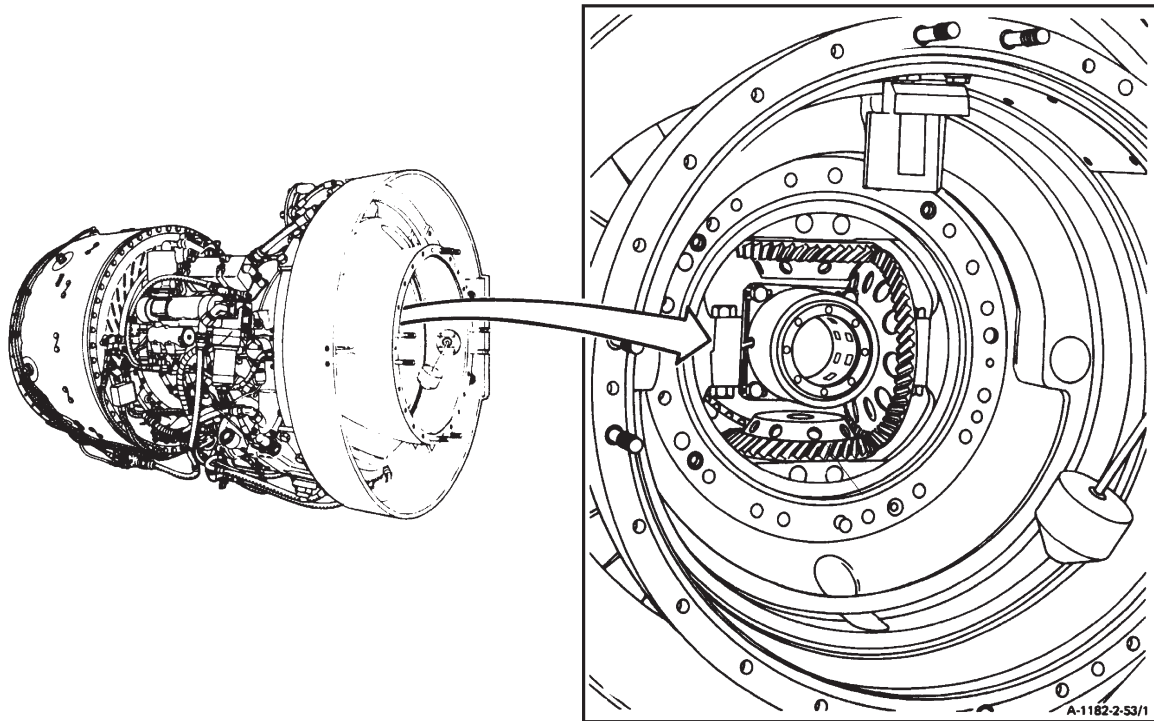

GO TO NEXT PAGE

2-63 INSTALL OUTPUT SHAFT SUPPORT HOUSING (Continued)

2-63

1. Install two packings (1) on transfer tube (2), and **install transfer tube (2)** in accessory gear assembly (3).

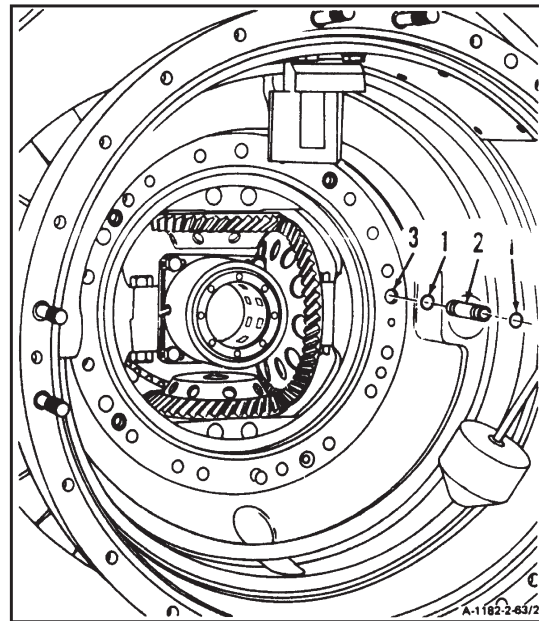

2. **Remove aircraft group cover (T29) (4)** from output shaft support housing (5).

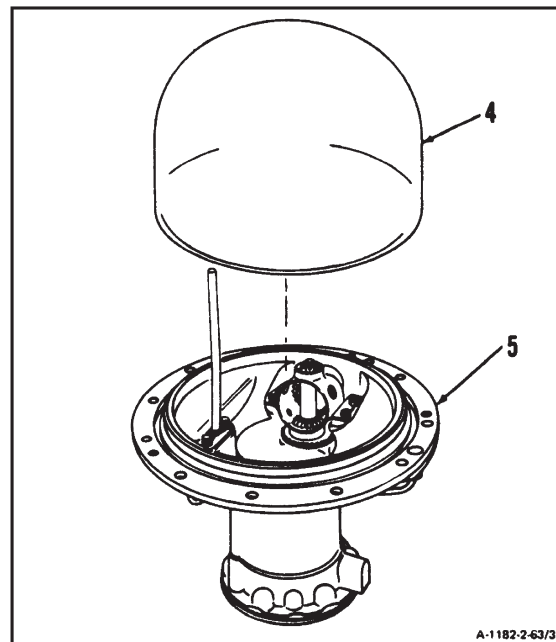

GO TO NEXT PAGE

3. Install two packings (6 and 7) in grooves (8 and 9) on output shaft support housing (5).

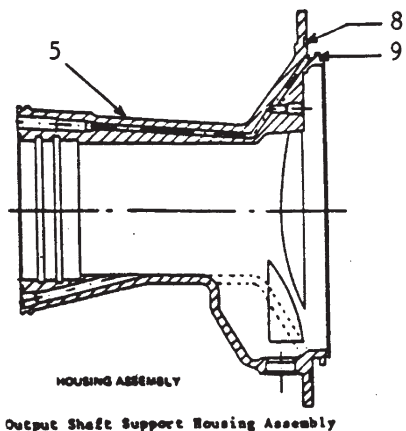

NOTE

Be sure that packing (7) is correctly installed on the aft face of the output shaft support housing (5) to the groove (9) above. Improper installation may interfere with the lubrication patch in housing (5) and may cause instances of low engine oil pressure.

4. Install packing (10) in groove (11) on output shaft support housing (5).

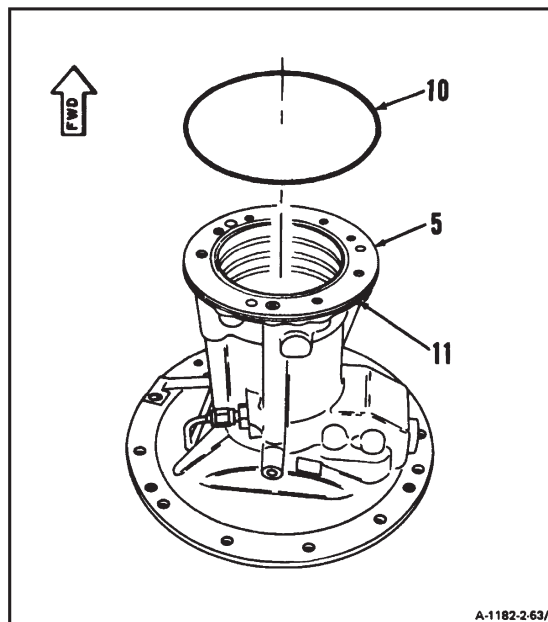
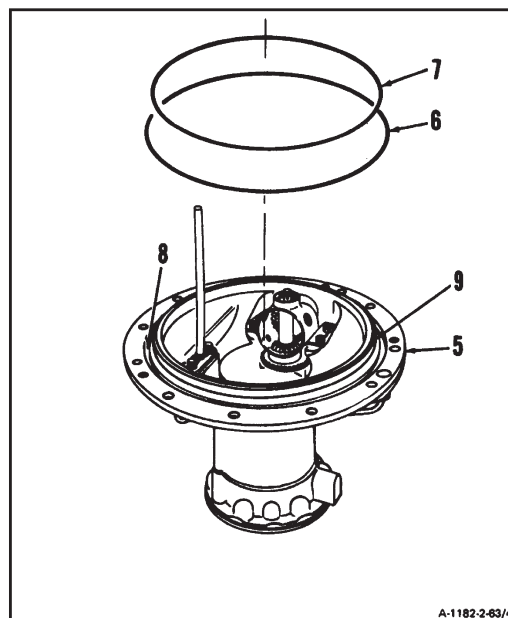

GO TO NEXT PAGE

2-63 INSTALL OUTPUT SHAFT SUPPORT HOUSING (Continued)**2-63**

5. Locate and mark irregularly shaped hole (12) in No. 3 bearing support (13) near 11-o'clock position looking aft. Use marking pencil (E34).

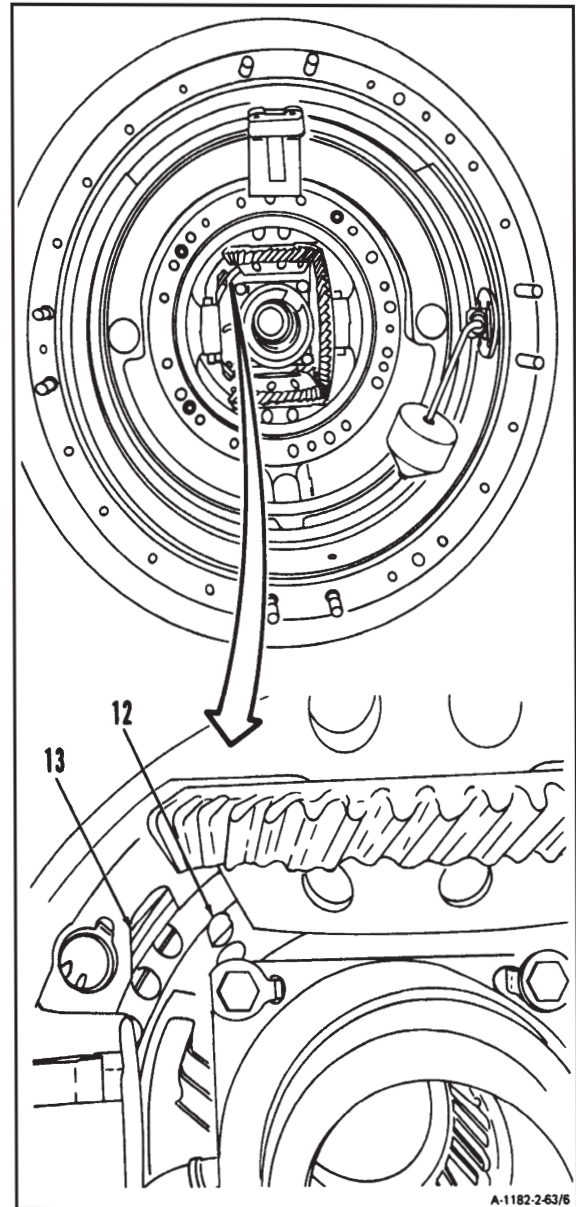
**GO TO NEXT PAGE**

CAUTION

In following step 6., be sure you are inserting bearing lube tube in the proper hole. Failure to do so will bend the tube and cause improper bearing lubrication. This would cause component damage and possible engine failure.

6. Align and partially insert bearing lube tube assembly (14) into marked hole (12).
7. Align hole (15) behind tube assembly (16) with transfer tube (2).

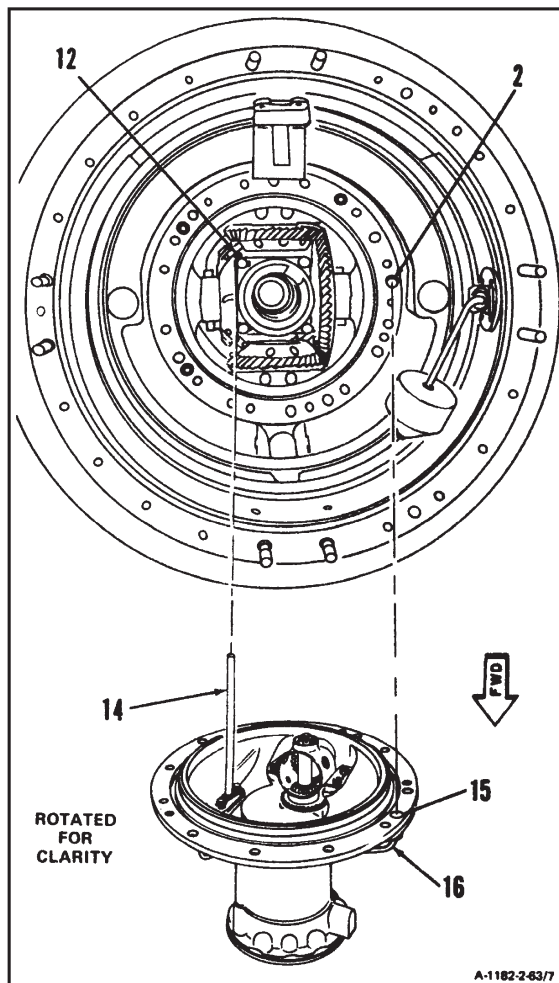

GO TO NEXT PAGE

CAUTION

In following step 8., be sure to install output shaft support housing carefully and evenly. You could easily damage the gears or air transfer tube packings which would cause improper engine operation.

8. Install output shaft support housing (5), 10 key washers (17) and 10 bolts (18) in inlet housing (19). Position key washers (17) with bent single tab (20) pointing aft and hooked over O.D. of flange (21).
9. Secure flange (22) of tube assembly (16) as follows:
 - a. Position two key washers (23) with bent single tab (24) pointing aft and hooked over outer side of flange (22).
 - b. Hold double tabs (25) of two key washers (23) on flange (22) of tube assembly (16). Use duckbill pliers.
 - c. Install two bolts (26) in inlet housing (19).
10. Bend up double tabs (25 and 27) of 10 key washers (17) and 2 key washers (23).

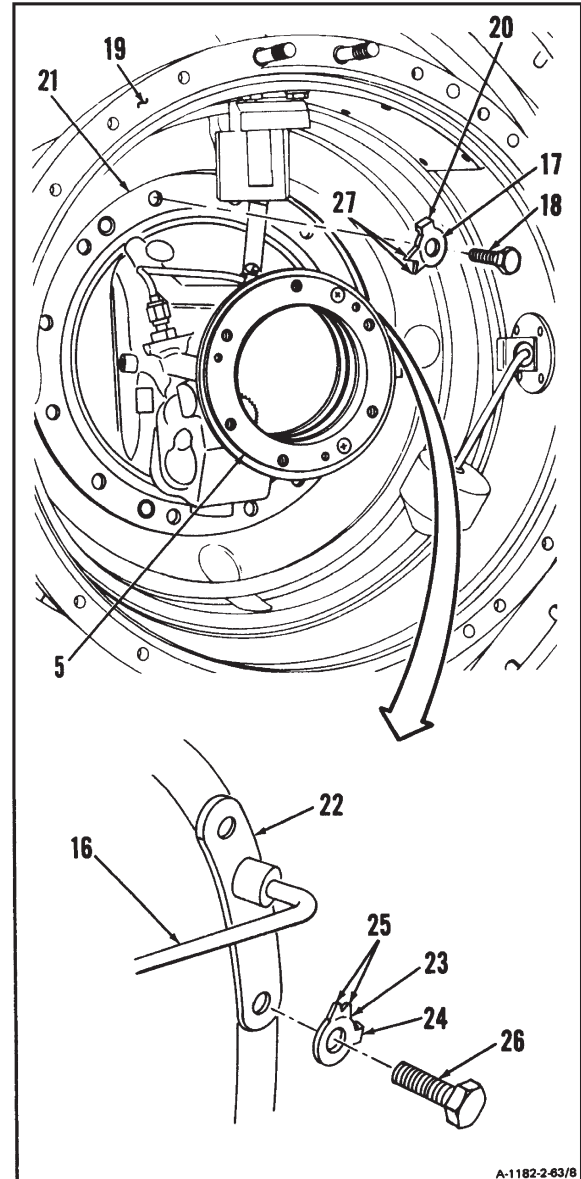
**INSPECT****GO TO NEXT PAGE**

FOLLOW-ON MAINTENANCE:

- Install Output Shaft (Task 9-10).
- Install Overspeed Drive and Outlet Cover Assembly (Task 5-23).
- Install Inlet Housing Cover Assembly (Task 2-57).
- Install Output Shaft Seal and Housing Assembly (Task 2-52).
- Service Engine Oil System (Task 1-74).

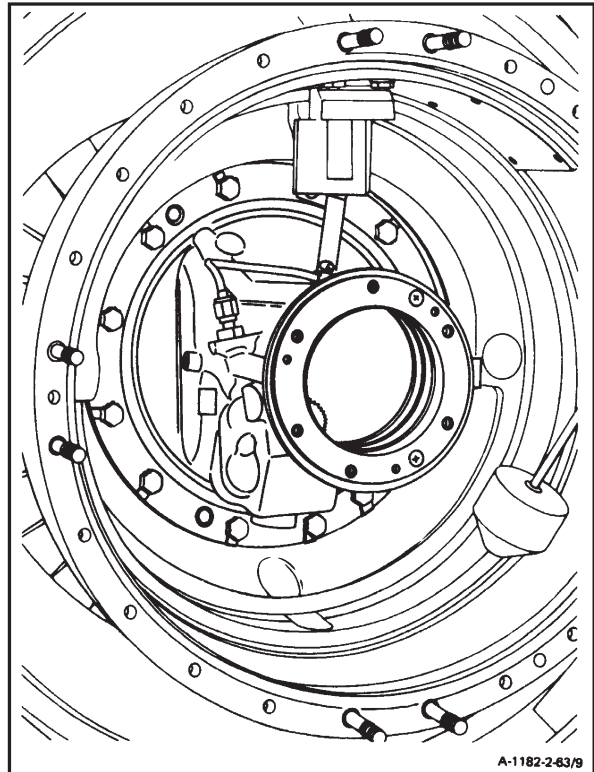

END OF TASK

Section XII. AIR INLET HOUSING ASSEMBLY - MAINTENANCE PROCEDURES

2-64 CLEAN AIR INLET HOUSING ASSEMBLY

2-84

INITIAL SETUP**Applicable Configurations:**

All

Tools:

None

Materials:

Dry Cleaning Solvent (E17)

Gloves (E20)

Wiping Rag (E58)

Personnel Required:

68B10 Aircraft Powerplant Repairer

WARNING

Dry cleaning solvent (E17) is flammable and toxic. It can irritate skin and cause burns. Use only in well-ventilated area, away from heat and open flame. In case of contact, immediately flush skin or eyes with water for at least 15 minutes. Get medical attention for eyes.

NOTE

Look for accumulations of dirt conforming to contour of air inlet. Buildup of foreign matter maybe difficult to detect because of the windswept contour it assumes.

1. Wear gloves (E20). **Clean** visible portion of **air inlet housing assembly (1)** with wiping rag (E58) dampened in dry cleaning solvent (E17).

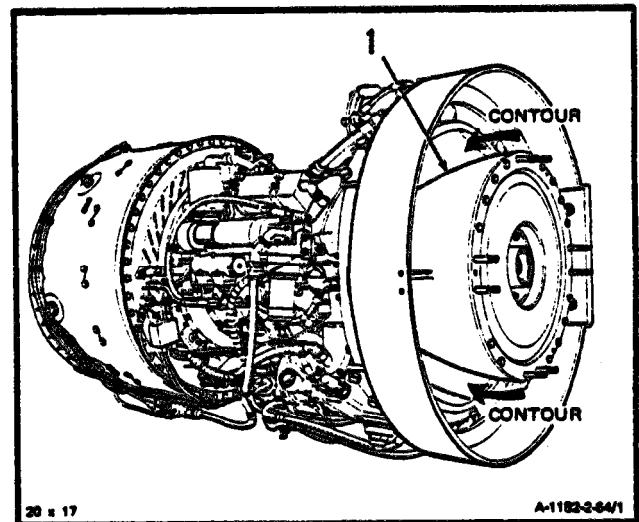
**FOLLOW-ON MAINTENANCE:**

Inspect Air Inlet Housing Assembly (Task 2-65).

END OF TASK

INITIAL SETUP

Applicable Configurations:

All

Tools:Technical Inspection Tool Kit,
NSN 5180-00-323-5114**Materials:**

None

Personnel Required:

68B10 Aircraft Powerplant Repairer

References:

Task 1-92

Task 1-119

NOTE

If there is foreign object damage (FOD), look for more FOD throughout engine. Perform a FOD inspection (Ref. Task 1-92).

1. **Inspect air inlet housing assembly (1)**, using strong light beam.
 - a. There shall be no cracks or FOD.
 - b. There shall be no paint damage.
 - c. Corrosion shall be treated using touch-up procedure for magnesium and magnesium alloys (Ref. Task 1-119).
 - (1) Visually inspect inlet housing for corrosion.
 - (2) A cumulative total of 8 inches of missing material as measured around the flange circumference is allowed.
 - (3) Individual defects shall not exceed 4 inches in length.
 - (4) Individual defects must be separated by a minimum of 1 inch of unaffected material.
 - (5) If within preceding limits, repair as outlined in Task 1-119.
 - (6) Any number of random minor corroded areas not exceeding 0.25 inch diameter are acceptable with repair.
 - (7) One single corroded area is acceptable after repair provided the area does not exceed 4 inches in length, 1.375 inches in width and 0.070 inch in depth at deepest point.
 - (8) Forward engine to overhaul if preceding limits are exceeded.
 - (9) If within preceding limits repair as outlined in Task 1-119.

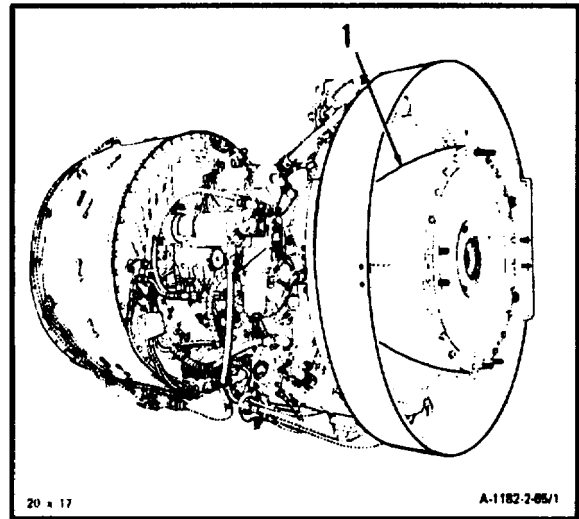
**GO TO NEXT PAGE**

2-65 INSPECT AIR INLET HOUSING ASSEMBLY (Continued)

2-65

2. Inspect air inlet housing (1) V-band mounting flange (2) for corrosion.

- a. There shall be no more than a cumulative total of eight inches of missing material around the circumference of V-band clamping flange (2).
- b. There shall be no individual defects (3) that exceed 4 inches in length.
- c. There shall be no individual defects (4) that are not separated by a minimum of one inch of unaffected material.
- d. Any defects that fall within limits outlined in preceding **steps a., b., and c.** shall be repaired. (Refer to Task 1-119).
- e. Any number of random minor corroded areas (5) not exceeding 0.025 inch diameter are acceptable with repair. (Refer to Task 1-119).
- f. A single (one) corroded area (6) is allowed after repair provided the area does not exceed 4 inches in length and 0.070 inch in depth.
- g. If limits in preceding steps a. thru e. are exceeded, forward engine to overhaul facility.

FOLLOW-ON MAINTENANCE:

None

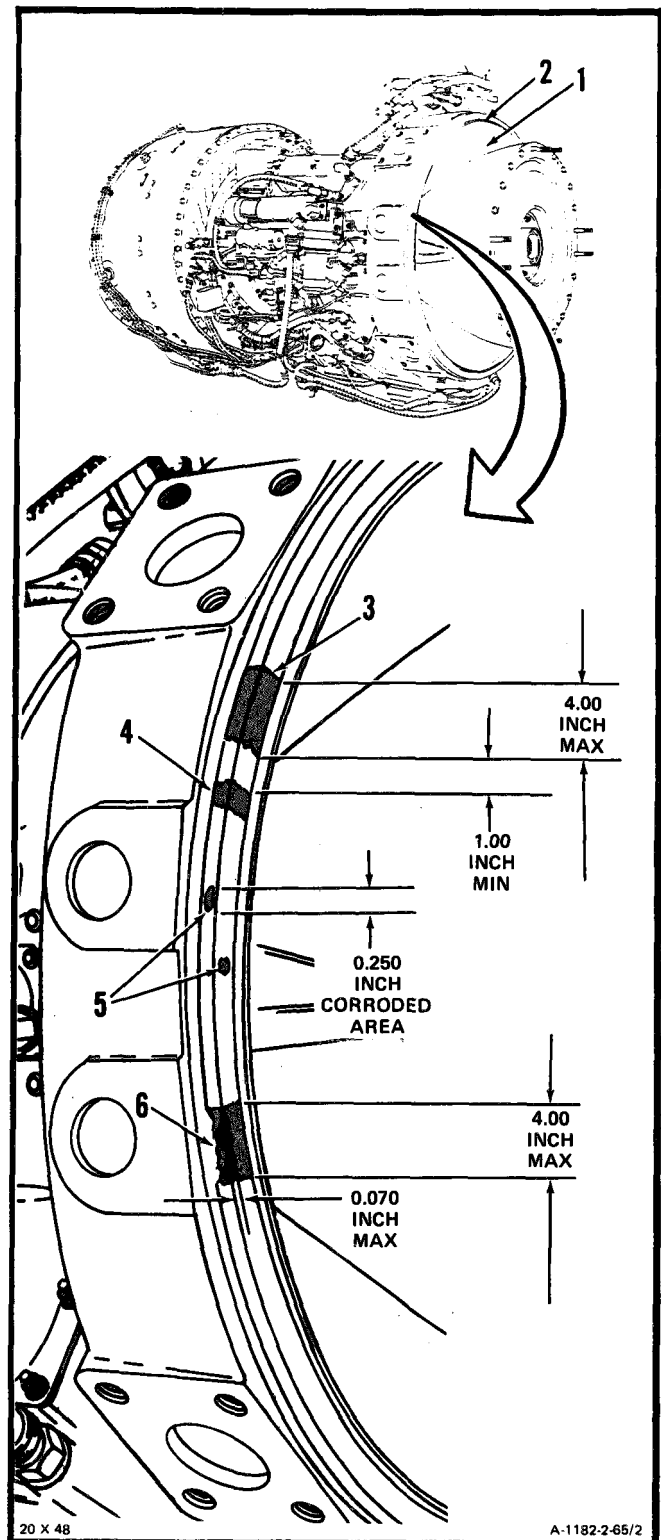

END OF TASK

2-66 REPAIR AIR INLET HOUSING ASSEMBLY

2-66

INITIAL SETUP**Applicable Configurations:**

All

Tools:

Technical Inspection Tool Kit,
NSN 5180-00-323-5114
Stainless Steel Wire Brush

Materials:

Clear Synthetic Sealant (E12)
Engine Gray Enamel (E22)

Personnel Required:

68B10 Aircraft Powerplant Repairer
68B30 Aircraft Powerplant Inspector

References:

Task 1-119

1. **Remove corrosion** using stainless steel wire brush.
2. **Repair damaged paint** on air inlet housing assembly (1) as follows:
 - a. Touch up spray painted surfaces, using engine gray enamel (E22) (Ref. Task 1-119).
 - b. Touch up clear synthetesine painted surfaces, using clear synthetic sealant (E12) (Ref. Task 1-119).

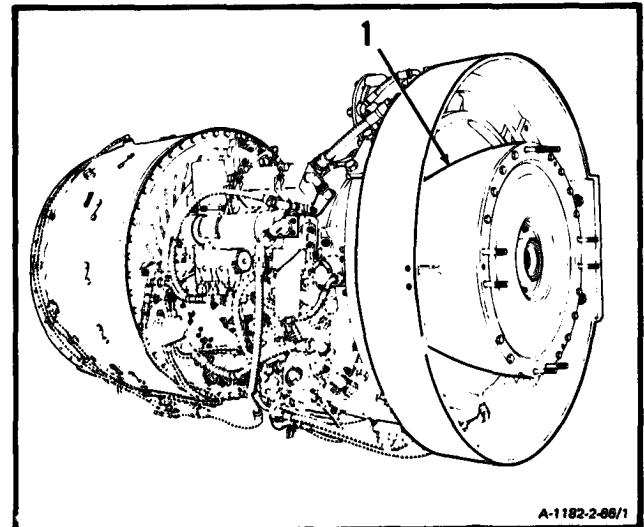
**INSPECT****FOLLOW-ON MAINTENANCE:**

None

END OF TASK

Section XIII. NO. 3 BEARING PACKAGE – MAINTENANCE PROCEDURES

2-67 REMOVE NO. 3 BEARING PACKAGE (AVIM)

2-67

INITIAL SETUP

Applicable Configurations:

All

Tools:

Powerplant Mechanic's Tool Kit,
NSN 5180-00-323-4944
Handling Tool (T16) (3)

Materials:

Wiping Rag (E58)

Personnel Required:

68B10 Aircraft Powerplant Repairer

Equipment Condition:

Engine Oil System Drained (Task 1-75)
Fuel Boost Pump Removed (Task 6-9)
Starter Drive Assembly Removed (Task 5-12)
Output Shaft Seal and Housing Removed
(Task 2-48)
Output Shaft Removed (Task 9-6)
Inlet Housing Cover Assembly Removed
(Task 2-53)
Tube Assembly Removed (Inlet Housing to
Main Oil Pump) (Task 8-50)

Overspeed Drive and Outlet Cover Assembly
Removed (Task 5-17)
Output Shaft Support Housing Removed
(Task 2-58)
Torquemeter Junction Box Removed (Task 9-1)
Torquemeter Head Assembly Removed (Task 9-11)
Accessory Gear Assembly Removed (Task 5-8)

General Safety Instructions:

WARNING

Lubricating oils (E32 and E33) cause paralysis if swallowed. Prolonged contact with them may irritate the skin. Handle only in well-ventilated areas away from heat and flame. Drain and store in approved metal safety containers. Avoid prolonged or repeated contact with skin and do not take internally. Wash contacted areas of skin thoroughly after handling. If irritation of skin results, get medical attention. Get medical attention for eyes.

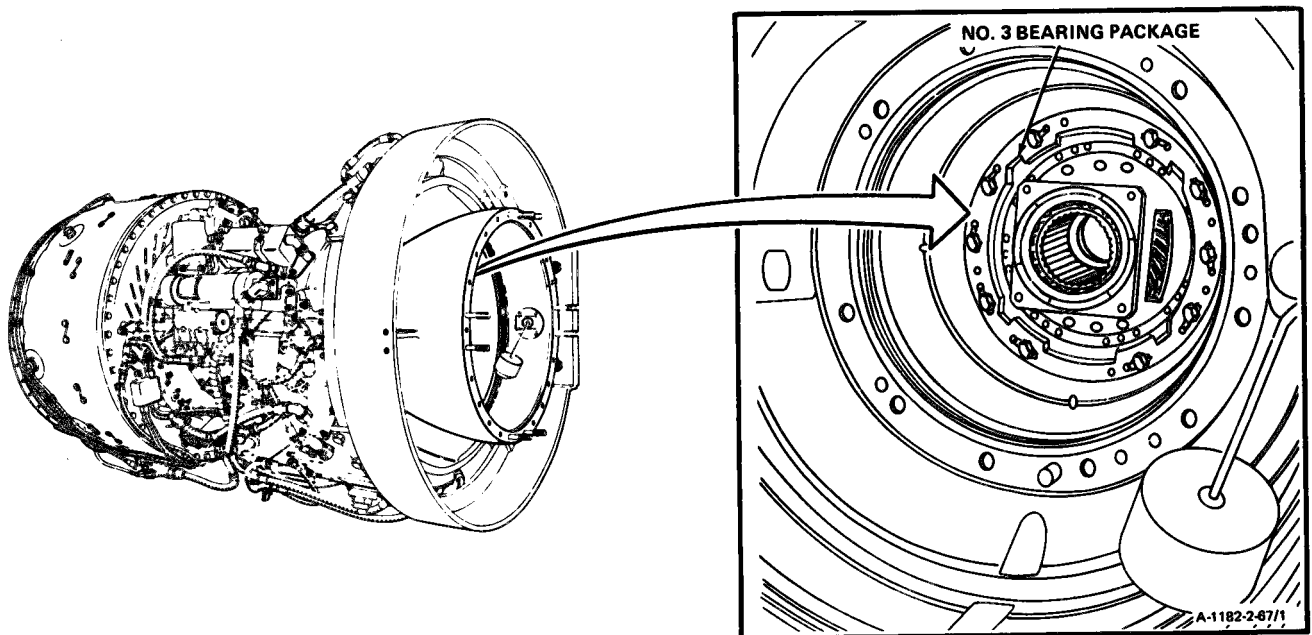

GO TO NEXT PAGE

1. Remove ten bolts (1) and key washers (2).

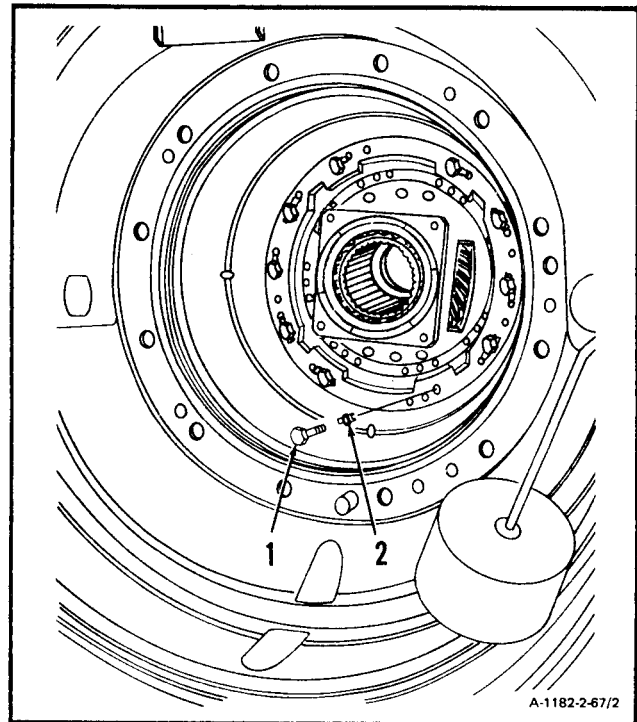

2. Thread first handling tool (T16) (3) into No. 3 bearing support (4) threaded hole at 2-o'clock position.

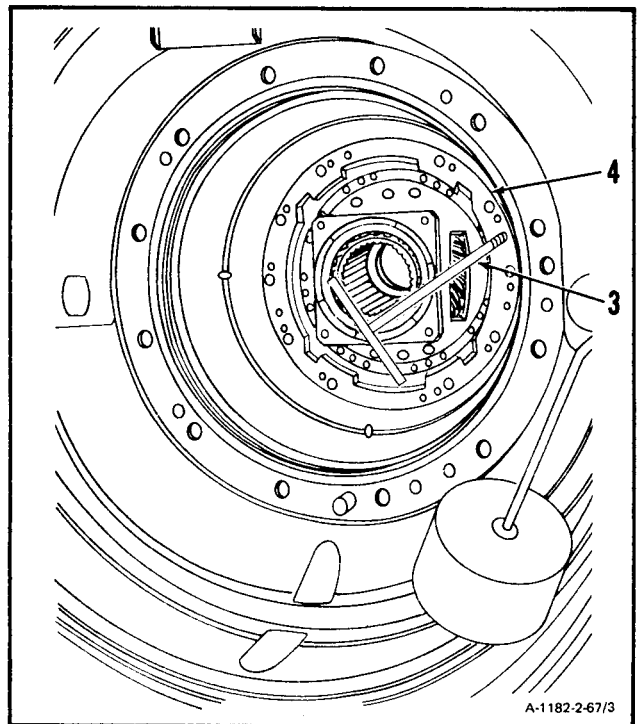

GO TO NEXT PAGE

2-67 REMOVE NO. 3 BEARING PACKAGE (AVIM) (Continued)

2-67

3. Thread second handling tool (T16) (3) into No. 3 bearing support (4) threaded hole at 8-o'clock position.

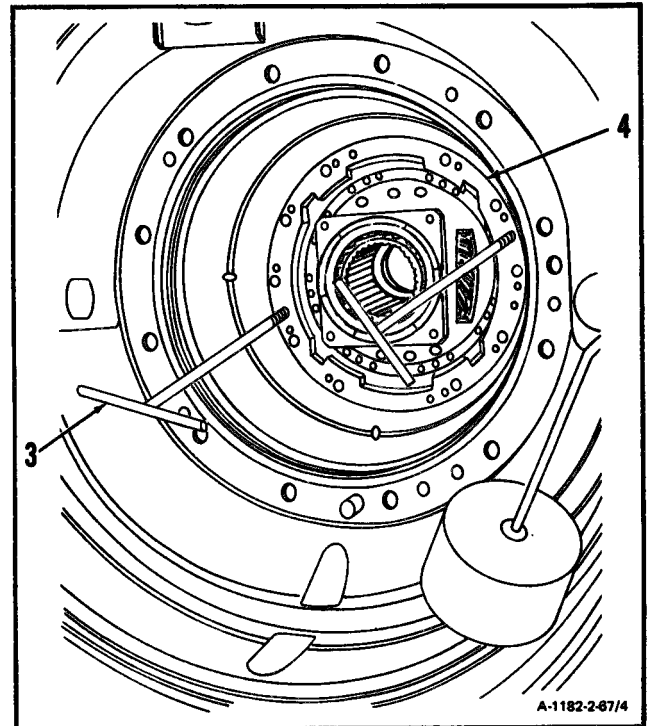

4. Thread third handling tool (T16) (3) into No. 3 bearing support (4) threaded hole at 11-o'clock position.

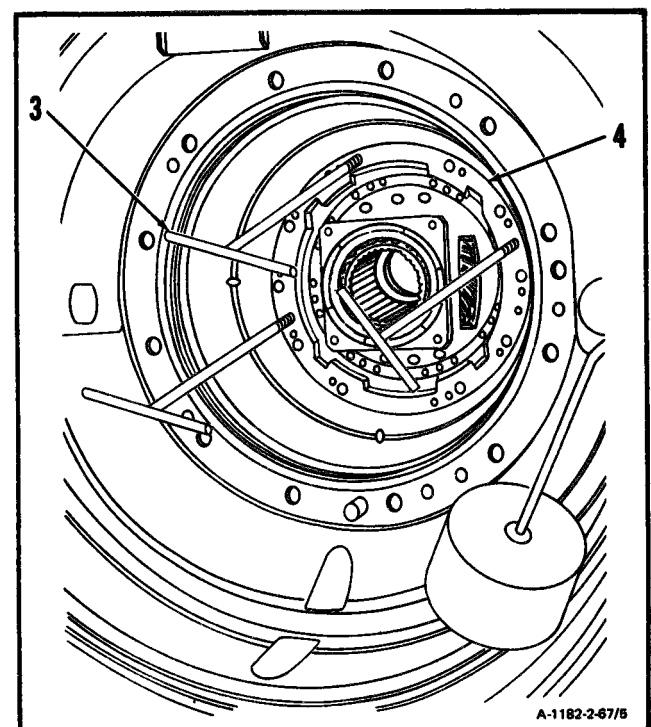

GO TO NEXT PAGE

CAUTION

No. 3 bearing support contains the inter-shaft seal with multiple carbon seal elements. Use care during removal procedure to prevent damaging the seal elements.

5. Remove No. 3 bearing support (4) using handling tools (T16) (3). Remove three handling tools.

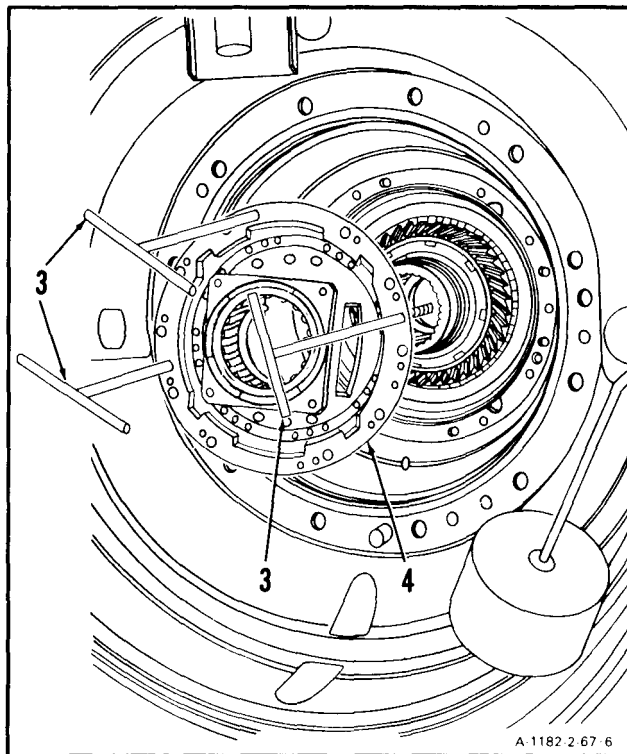

GO TO NEXT PAGE

6. Remove shim (5).

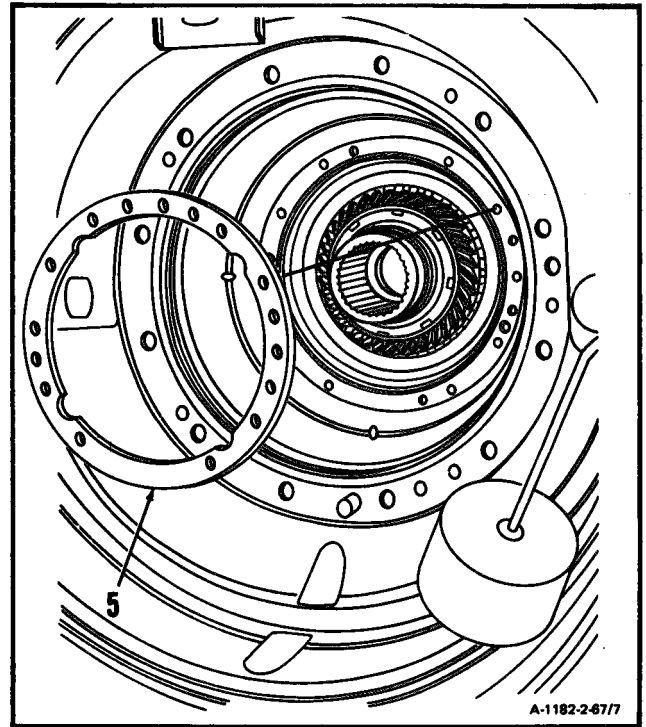

FOLLOW-ON MAINTENANCE:

None

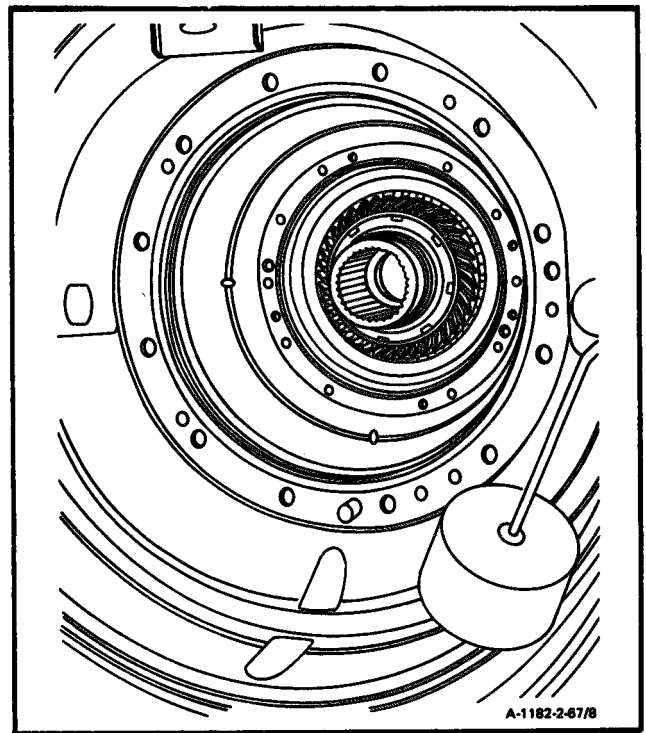

END OF TASK

INITIAL SETUP**Applicable Configurations:**

All

Tools:

Powerplant Mechanic's Tool Kit,
NSN 5180-00-323-4944
Sleeve Bushing (Appendix E)
Removal Tool (Appendix E)
Arbor Press

Materials:

Lint-Free Cloth (E26)

Personnel Required:

68B10 Aircraft Powerplant Repairer

Equipment Condition:

Engine Oil System Drained (Task 1-75)
Fuel Boost Pump Removed (Task 6-9)
Starter Drive Assembly Removed (Task 5-12)
Output Shaft Seal and Housing Removed
(Task 2-48)
Output Shaft Removed (Task 9-6)
Inlet Housing Cover Assembly Removed
(Task 2-53)
Tube Assembly Removed (Inlet Housing to
Main Oil Pump) (Task 8-50)
Overspeed Drive and Outlet Cover Assembly
Removed (Task 5-17)
Output Shaft Support Housing Removed
(Task 2-58)
Torquemeter Junction Box Removed (Task 9-1)
Torquemeter Head Assembly Removed (Task 9-11)
Accessory Gear Assembly Removed (Task 5-8)
No. 3 Bearing Package Removed (Task 2-67)

1. Place sleeve bushing (Appendix E) (1) on a suitable work bench.
2. Place No. 3 bearing support housing (2.) on sleeve bushing (Appendix E) (1).

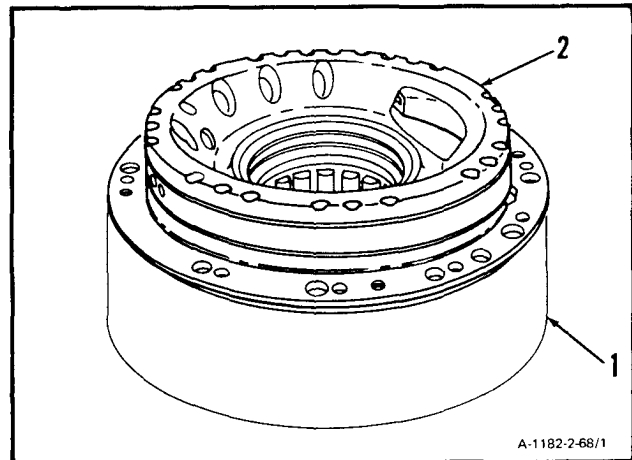
**GO TO NEXT PAGE**

3. Place removal tool (Appendix E) (3) on seal (4). Press seal (4) and bearing (5) out of No. 3 bearing support housing (2).

CAUTION

Protect bearings from damage. Handle only in clean area. Use clean, lint-free cloth (E26). Damaged bearings can cause engine failure.

4. Remove No. 3 bearing support housing (2) from sleeve bushing (Appendix E) (1).

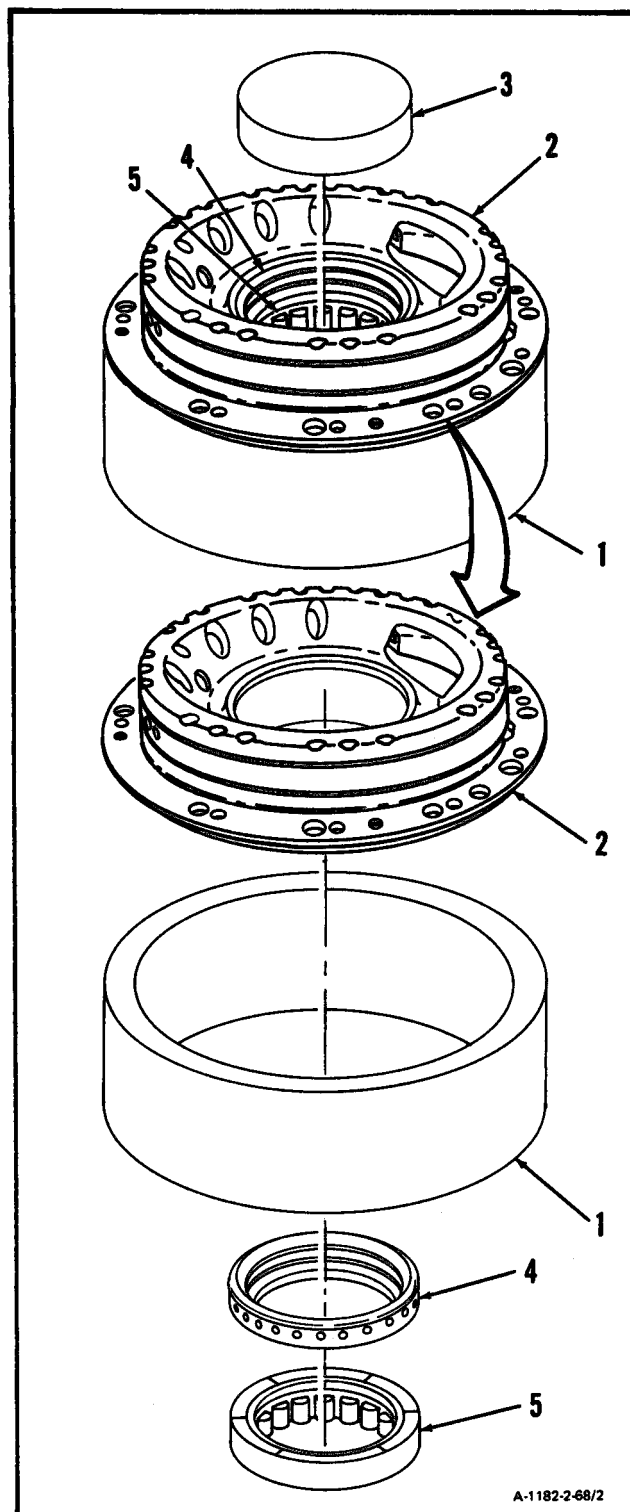

FOLLOW-ON MAINTENANCE:

None

END OF TASK

INITIAL SETUP**Applicable Configuration:**

All

Tools:

Powerplant Mechanic's Tool Kit,
NSN 5180-00-323-4944

Goggles

Compressed Air Source

Fiber Brush

Materials:

Dry Cleaning Solvent (E17)

Gloves (E20)

Lint-Free Cloth (E26)

Lubricating Oil (E32)

Personnel Required:

68B10 Aircraft Powerplant Repairer

Equipment Condition:

Engine Oil System Drained (Task 1-75)

Fuel Boost Pump Assembly Removed (Task 6-9)

Starter Drive Assembly Removed (Task 5-12)

Output Shaft Seal and Housing Assembly
Removed (Task 2-48)

Output Shaft Removed (Task 9-6)

Inlet Housing Cover Assembly Removed
(Task 2-53)Tube Assembly Removed (Inlet Housing to
Main Oil Pump (Task 8-50)Overspeed Drive and Outlet Cover
Assembly Removed (Task 5-1 7)Output Shaft Support Housing Removed
(Task 2-58)

Torquemeter Junction Box Removed (Task 9-1)

Torquemeter Head Assembly Removed (Task 9-11)

Accessory Gear Assembly Removed (Task 5-8)

No. 3 Bearing Package Removed (Task 2-67)

No. 3 Bearing Package Disassembled (Task 2-68)

General Safety Instructions:**WARNING**

Dry cleaning solvent (E17) is flammable and toxic. It can irritate skin and cause burns. Use only in well-ventilated area, away from heat and open flame. In case of contact, immediately flush skin or eyes with water for at least 15 minutes. Get medical attention for eyes.

WARNING

When using compressed air for cleaning, use approved protective equipment for eyes and face. Do not use more than 30 psig air pressure. Do not direct air toward yourself or another person. Failure to comply could result in injury to eyes or skin. In case of injury, get medical attention.

GO TO NEXT PAGE

1. Clean No. 3 bearing support (1) as follows:

- a. Wear gloves (E20). Immerse No. 3 bearing support (1) in dry cleaning solvent (E17).
- b. Remove contaminants by scrubbing with a fiber brush.
- c. Wear goggles. Blow dry support (1) using clean, dry compressed air.

CAUTION

Protect bearings from damage. Handle only in clean area. Use clean, lint-free cloth (E26). Damaged bearings can cause engine failure.

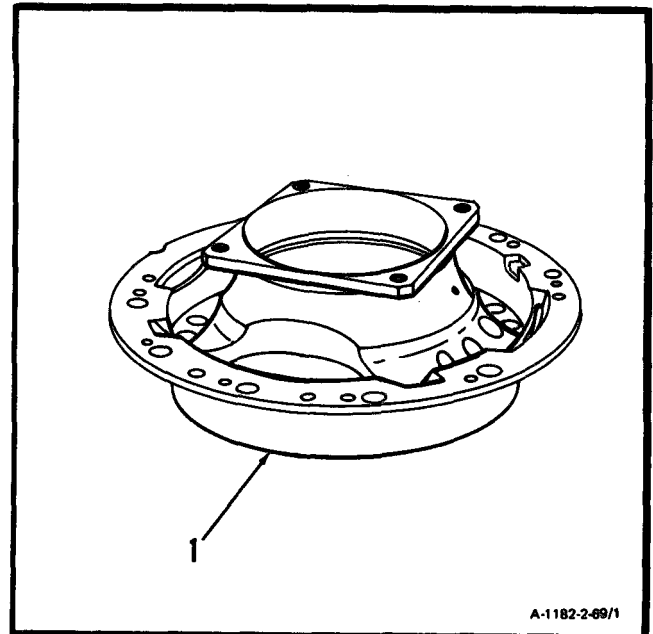

2. Clean bearing (2).

- a. Immerse bearing (2) in clean dry-cleaning solvent (E17) and agitate. Rinse in clean dry-cleaning solvent (E17).
- b. Wipe dry. Use clean, dry lint-free cloth (E26).
- c. Blow **dry**. Use clean, dry compressed air.

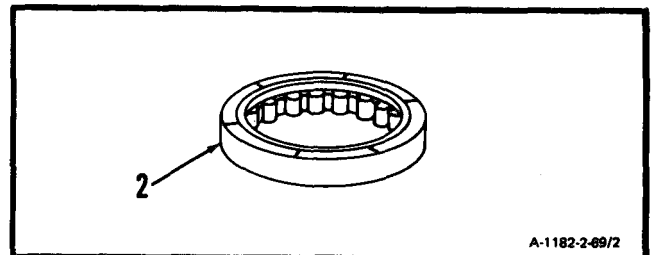

WARNING

Lubricating oils (E32 and E33) cause paralysis if swallowed. Prolonged contact with them may irritate the skin. Handle only in well-ventilated areas away from heat and flame. Drain and store in approved metal safety containers. Avoid prolonged or repeated contact with skin and do not take internally. Wash contacted areas of skin thoroughly after handling. If irritation of skin results, get medical attention. Get medical attention for eyes.

- d. Coat bearing (2) with lubricating oil (E32) and wrap in clean, lint-free cloth (E26).

CAUTION

Protect seals from damage. Handle only in clean area. Use clean, lint-free cloth (E26). Damaged seals can cause engine failure.

3. Clean seal (3).

- a. **Immerse seal (3) in dry-cleaning solvent (E17)** and agitate. Rinse in clean dry-cleaning solvent (E17).
- b. Wipe dry. Use clean, dry lint-free cloth (E26).
- c. **Blow dry seal (3).** Use clean, dry compressed air.
- d. Wrap in clean, lint-free cloth (E26).

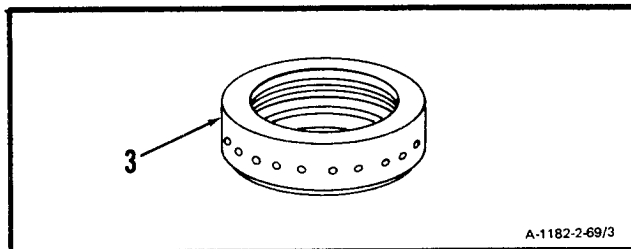
**4. Clean shim (4).**

- a. Wear gloves (E20). **Immerse shim in dry-cleaning solvent (E17) and agitate.** Rinse in dry-cleaning solvent.
- b. Wipe dry. Use clean, dry lint-free cloth (E26).

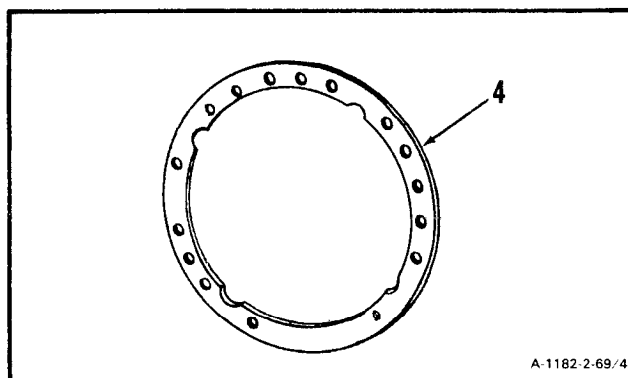
**FOLLOW-ON MAINTENANCE:**

Inspect No. 3 Bearing Package (Task 2-70)

END OF TASK

2-70 INSPECT NO. 3 BEARING PACKAGE (AVIM)

2-70

INITIAL SETUP**Applicable Configurations:**

All

Tools:Technical Inspection Tool Kit,
NSN 5180-00-323-5114**Materials:**

None

Personnel Required:

68B30 Aircraft Powerplant Inspector

Equipment Condition:

Off Engine Task

1. Inspect bearing support (1) as follows:

- a. There shall be no cracks.
- b. There shall be no scoring deeper than 0.010 inch in bore (2).
- c. There shall be no nicks or scratches deeper than 0.020 inch on remainder of housing (3).

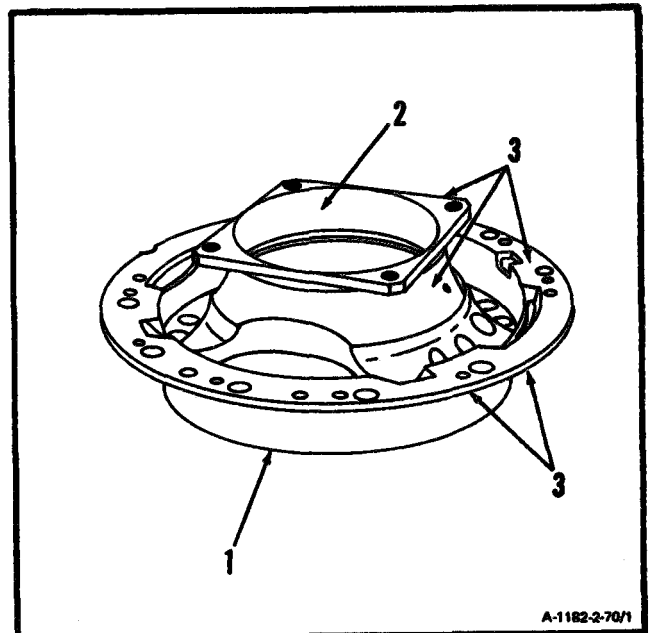

A-1182-2-70/1

GO TO NEXT PAGE

2. Inspect seal (4). There shall be no chipping or scoring of carbon elements (5).

3. Inspect bearing (6) as follows:

- a. There shall be no rust or broken parts.
- b. There shall be no pitting or spalling on the rolling surfaces (7) deeper than 0.002 inch.
- c. There shall be no foreign matter clogging the bearing which would obstruct free rotation.
- d. There shall be no purple, red-purple or blue discoloration.

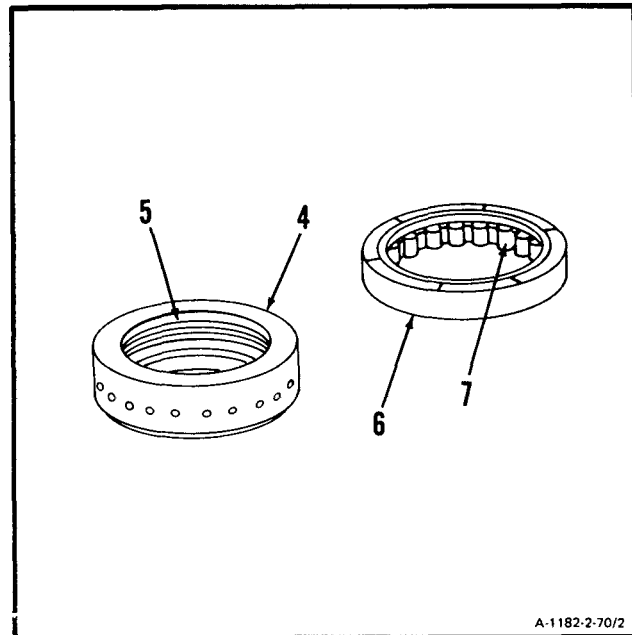

4. Inspect shim (8). There shall be no cracks.

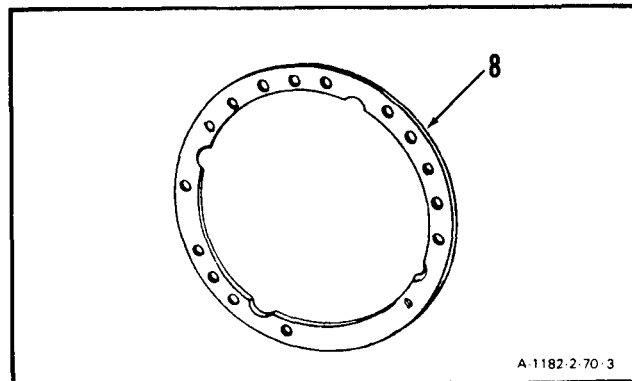

FOLLOW-ON MAINTENANCE:

None

END OF TASK

2-71 ASSEMBLE NO. 3 BEARING PACKAGE (AVIM)

2-71

INITIAL SETUP

Applicable Configurations:

All

Tools:

Powerplant Mechanic's Tool Kit,
NSN 5180-00-3234944
Technical Inspection Tool Kit,
NSN 5180-00-323-5114
Sleeve Bushing (Appendix E)
Installation Tool (Appendix E)
Arbor Press

Materials:

Lint-Free Cloth (E26)

Personnel Required:

68B10 Aircraft Powerplant Repairer
68B30 Aircraft Powerplant Inspector

Equipment Condition:

Off Engine Task

1. Place sleeve bushing (Appendix E) (1) on a suitable work bench.
2. Place No. 3 bearing support housing (2) on sleeve bushing (Appendix E) (1).
3. Place seal (3) on No. 3 bearing support housing (2) with small inside diameter (4) facing up.
4. Place installation tool (Appendix E) (5) on seal (3). **Press seal into No. 3 bearing support housing (2).**

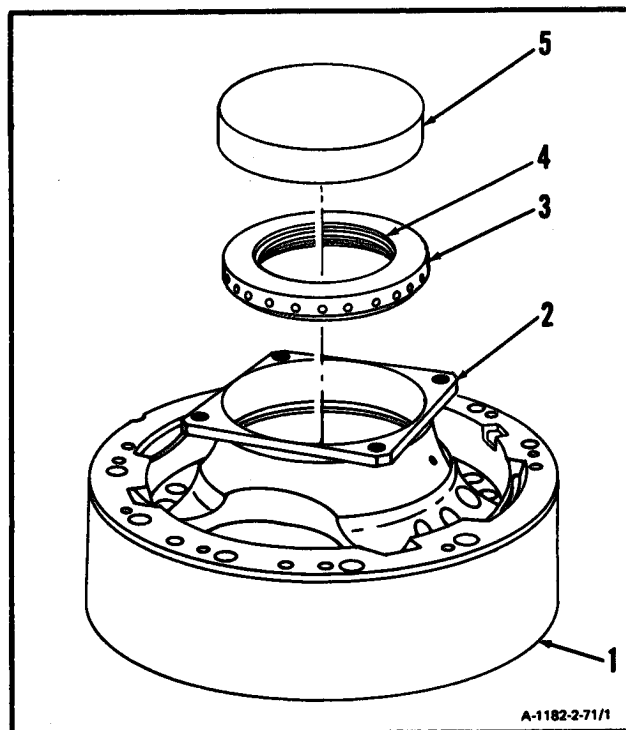
**GO TO NEXT PAGE**

CAUTION

Protect bearings from damage. Handle only in clean area. Use clean, lint-free cloth (E26). Damaged bearings can cause engine failure.

5. Place bearing (6) on No. 3 bearing support housing (2) with part number (7) facing up.
6. Place installation tool (Appendix E) (5) on bearing (6). **Press bearing (6) into bearing support housing (2)** until bearing (6) is seated.

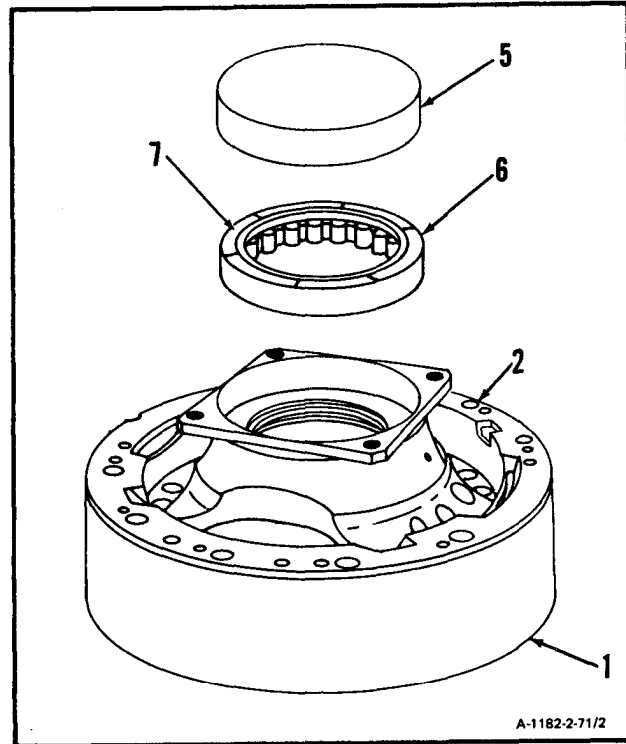
**INSPECT****FOLLOW-ON MAINTENANCE:**

None

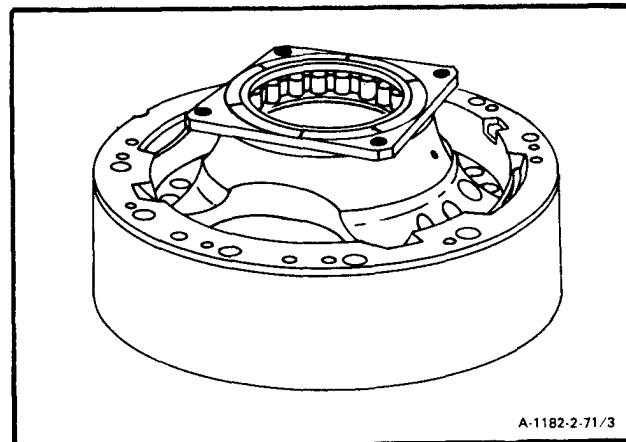
**END OF TASK**

2-72 INSTALL NO. 3 BEARING PACKAGE (AVIM)

2-72

INITIAL SETUP**Applicable Configurations:**

All

Tools:

Powerplant Mechanic's Tool Kit,
NSN 5180-00-323-4944
Technical Inspection Tool Kit,
NSN 5180-00-323-5114
Alignment Pin (T2) (2)
Phenolic Drift (Appendix E)
Micrometer Depth Gage
Outside Micrometer Caliper Set
Slave Bolt (MS9490-16) (2)
Slave Washer (AN960C416L) (2)
Rawhide Mallet

Materials:

Shortening Compound (E46)

Parts:

Shim
Key Washers

Personnel Required:

68B10 Aircraft Powerplant Repairer
68B30 Aircraft Powerplant Inspector

References:

TM 55-2840-254-23P

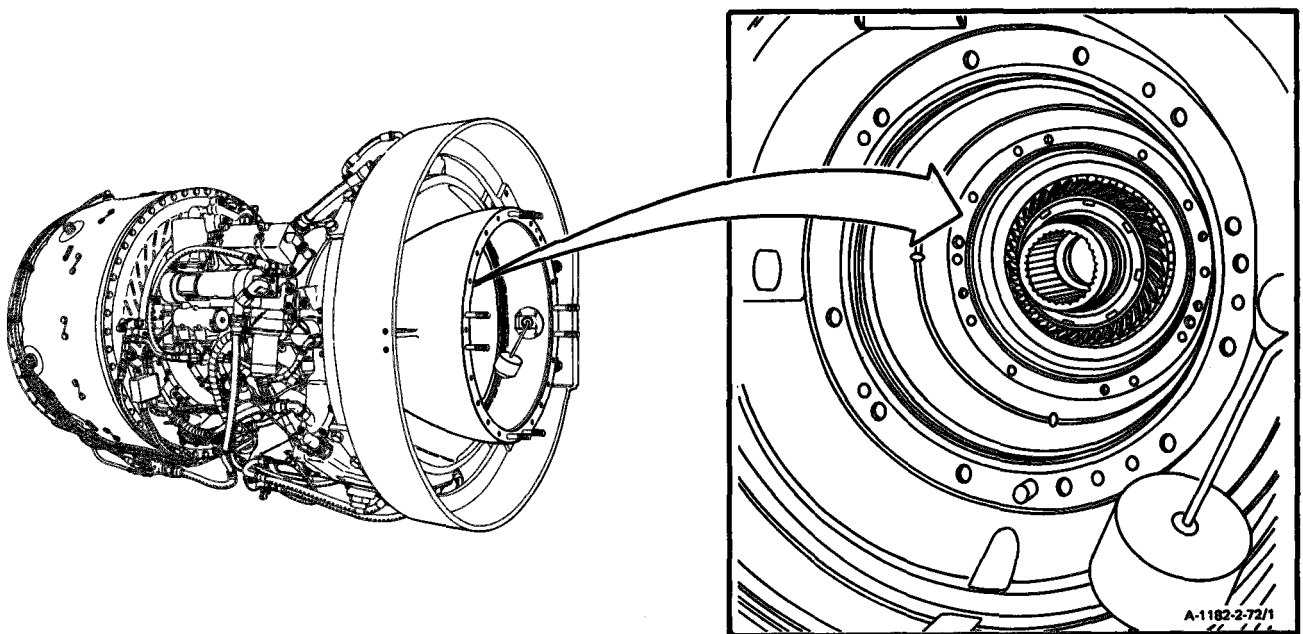
**GO TO NEXT PAGE**

1. Temporarily install two slave bolts (1) and two slave washers (2) in holes (3) at 5-o'clock and 11-o'clock positions.

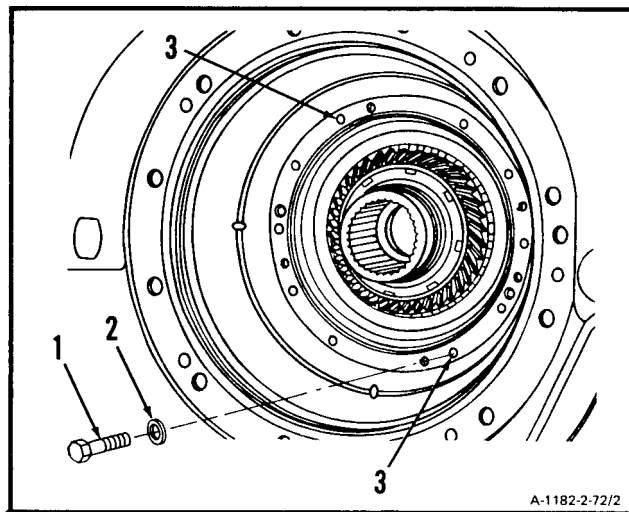

2. Push No. 1 bearing outer race (4) aft. Measure from inner bolt circle mounting flange surface of inlet housing (5) to No. 1 bearing outer race (4). Record as Dimension A (6).

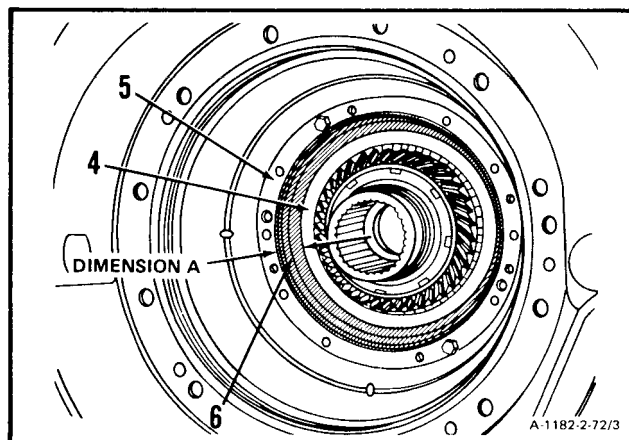

3. Measure from aft rim surface of No. 3 bearing support housing (7) to No. 3 bearing support housing flange mounting surface (8). Record as Dimension B (9).

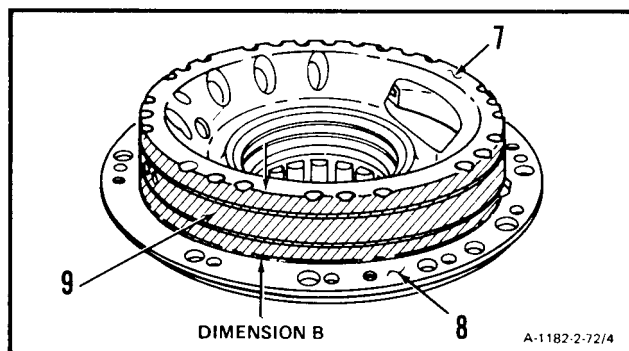

4. Subtract Dimension A measurement recorded in step 2 from Dimension B measurement recorded in step 3. Record result.

5. Find result recorded in step 4. in shim selection table and read across to determine shim thickness you will need.

GO TO NEXT PAGE

SHIM SELECTION TABLE	
IF RESULT IS (INCHES)	SHIM THICKNESS NEEDED (INCHES)
0.005	NONE
0.006	NONE
0.007	0.002
0.008	0.002
0.009	0.004
0.010	0.004
0.011	0.006
0.012	0.006
0.013	0.008
0.014	0.008
0.015	0.010
0.016	0.010
0.017	0.012
0.018	0.012
0.019	0.014
0.020	0.014
0.021	0.016
0.022	0.016
0.023	0.018
0.024	0.018
0.025	0.020
0.026	0.020
0.027	0.022
0.028	0.022
0.029	0.024
0.030	0.024
0.031	0.026
0.032	0.026
0.033	0.028
0.034	0.028
0.035	0.030
0.036	0.030
0.037	0.032
0.038	0.032

GO TO NEXT PAGE

6. Prepare shim (10). Peel off layers (11) as required.

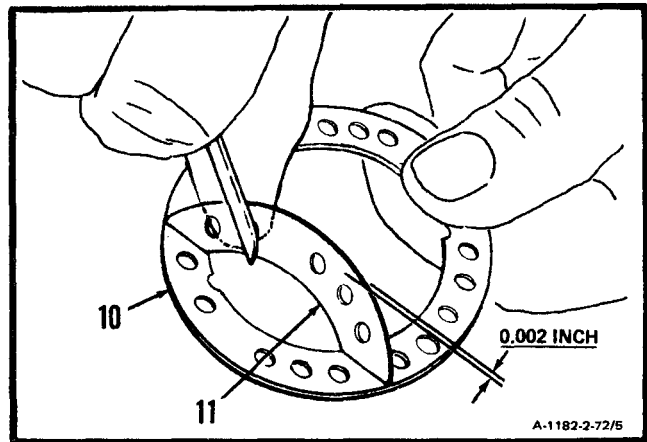

7. Measure thickness of shim (10) with outside micrometer caliper, and check against shim selection table.

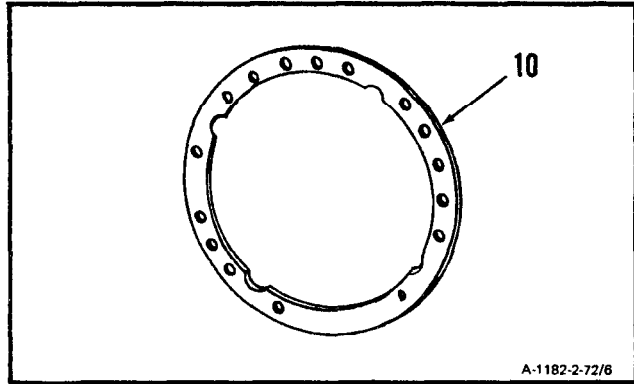

GO TO NEXT PAGE

2-72 INSTALL NO. 3 BEARING PACKAGE (AVIM) (Continued)

2-72

8. Remove two slave bolts and washers.
9. **Install first alignment pin (T2) (12)** into bolt hole through inlet housing inner flange (13) and compressor rotor front bearing housing at the 11-o'clock position.
10. **Install second alignment pin (T2) (12)** at the 5-o'clock position.

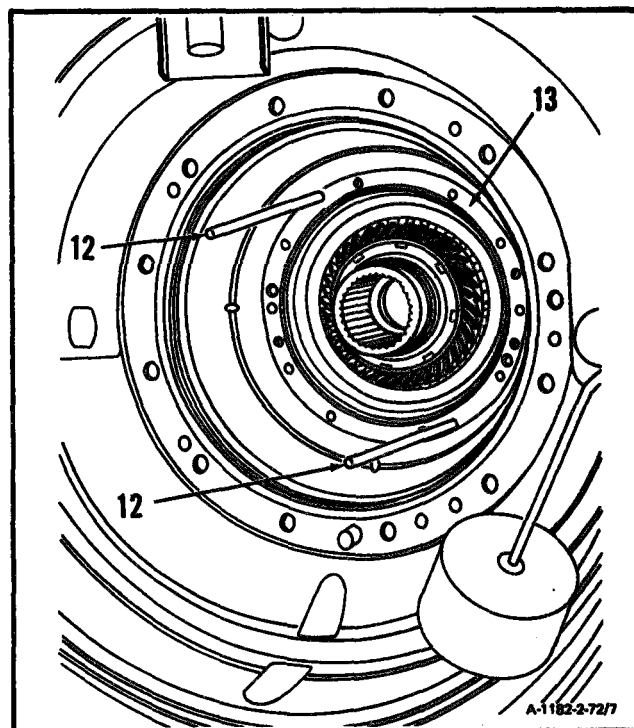

11. Position shim (10) with two widely spaced holes (14) at 7-o'clock and 10-o'clock location. Align holes (14) with two widely spaced holes (15) on inlet housing inner flange (13).
12. **Install shim (10)** over alignment pins (T2) (12).

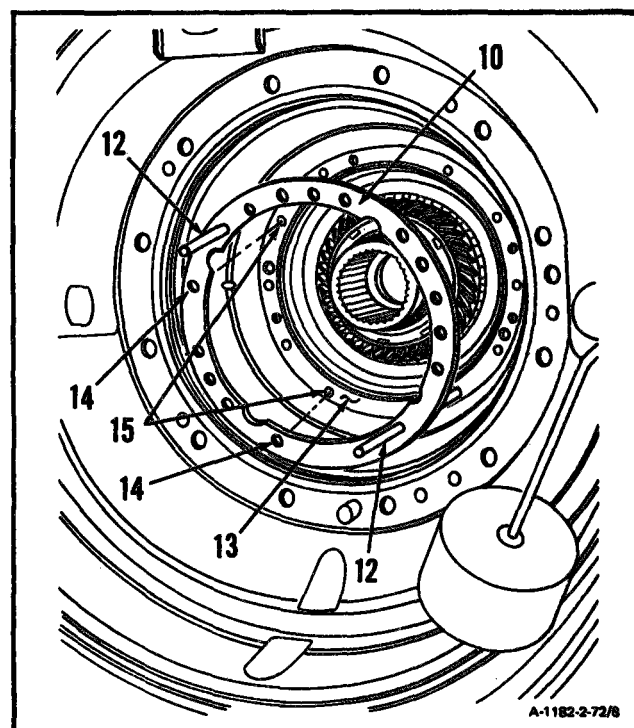
**GO TO NEXT PAGE**

13. Pack bearing (16) with shortening compound (E46) and press rollers (17) forward into retainer (18).
14. **Position No. 3 bearing package (19)** over alignment pins (T2) (12). Make sure that notch (20) is at the 6-o'clock position.

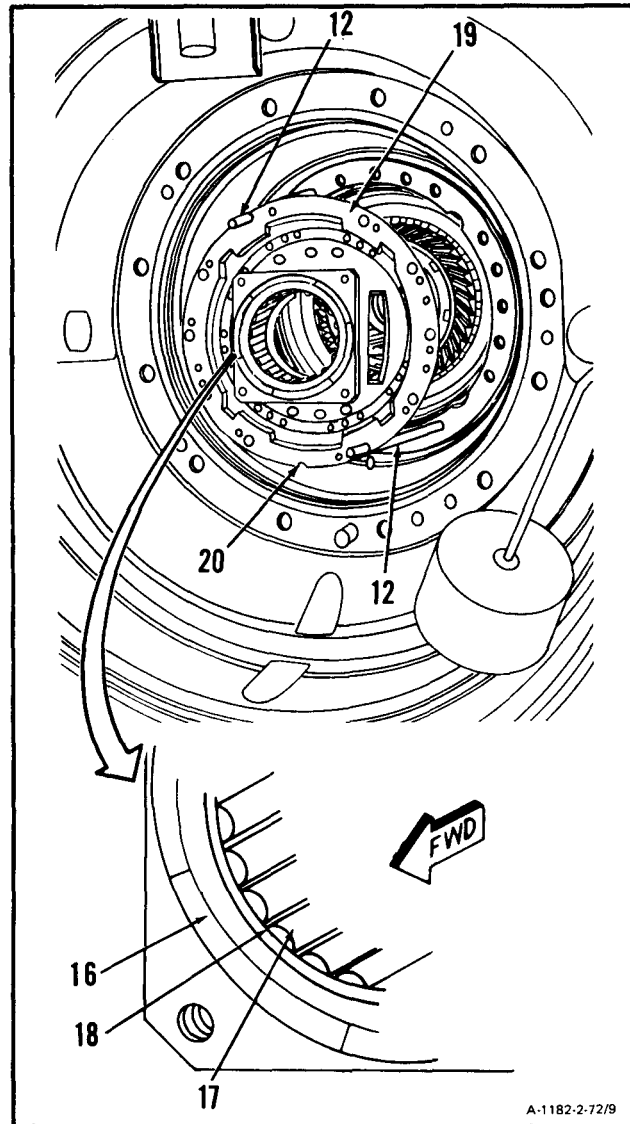

GO TO NEXT PAGE

CAUTION

In following step 15., be sure bearing rollers are recessed into retainer before installing bearing package. Bearing could easily be damaged. This would cause engine failure.

15. Install No. 3 bearing package (19) into inlet housing (5) until aft carbon seal (21) is seated on compressor shaft (22).

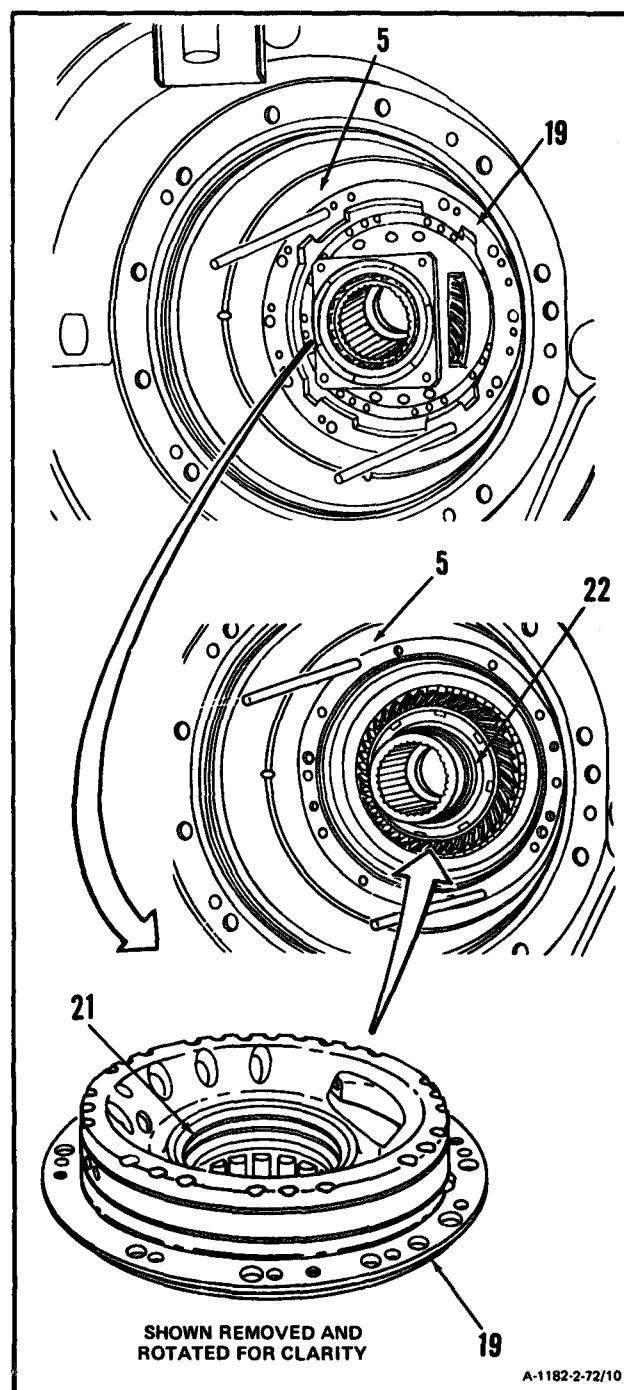

GO TO NEXT PAGE

CAUTION

In following step 16. to prevent damage to carbon seals, tap No. 3 bearing support lightly. Do not cock No. 3 bearing support while tapping. Carbon elements could easily be broken. This would result in oil leakage and damage to engine.

16. Using a rawhide mallet and a phenolic drift (Appendix E), **carefully tap No. 3 bearing package (19) on square flange (23)** to seat against inlet housing (5).

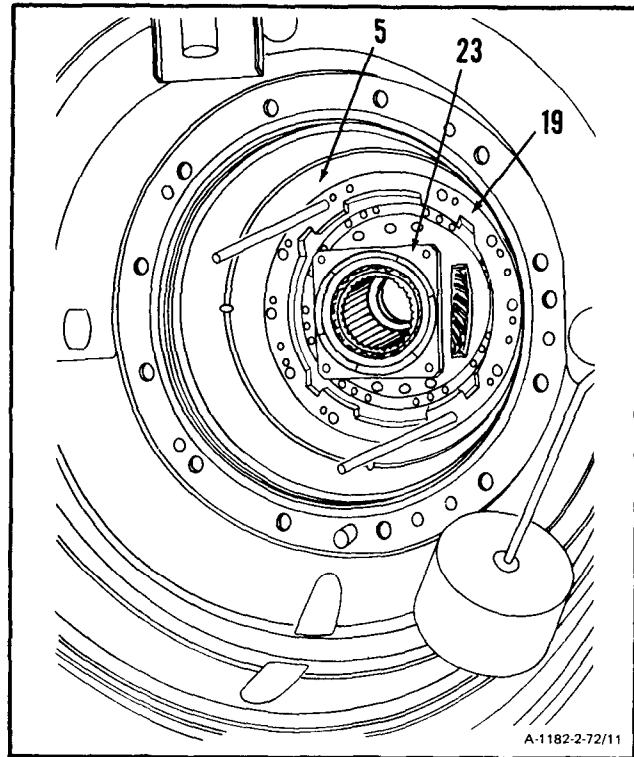

GO TO NEXT PAGE

2-72 INSTALL NO. 3 BEARING PACKAGE (AVIM) (Continued)

2-72

17. Remove alignment pins (T2).
18. **Install ten bolts (24) and key washers (25) in mounting holes of No. 3 bearing support.**
19. Tighten bolts (24) in opposite pairs. Lock bolts (24) by bending tabs of key washers (25).

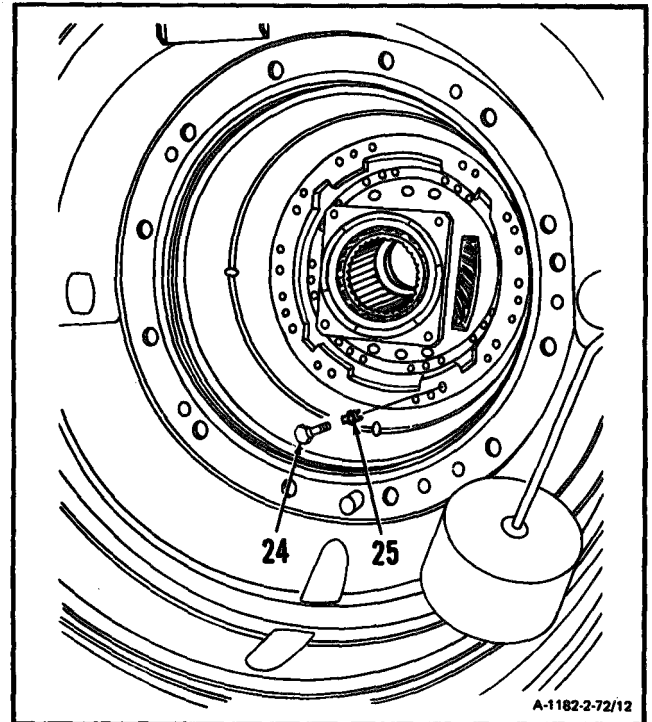
**INSPECT****FOLLOW-ON MAINTENANCE:**

- Install Accessory Gear Assembly (Task 5-11)
- Install Torquemeter Head Assembly (Task 9-14).
- Install Torquemeter Junction Box (Task 9-5).
- Install Output Shaft Support Housing (Task 2-63).
- Install Overspeed Drive and Outlet Cover Assembly (Task 5-23).
- Install Tube Assembly (Inlet Housing to Main Oil Pump) (Task 8-51)
- Install Inlet Housing Cover Assembly (Task 2-57).
- Install Output Shaft (Task 9-10).
- Install Output Shaft Seal and Housing Assembly (Task 2-52).
- Install Starter Drive Assembly (Task 5-16).
- Install Fuel Boost Pump Assembly (Task 6-13).
- Service Engine Oil System (Task 1-74).

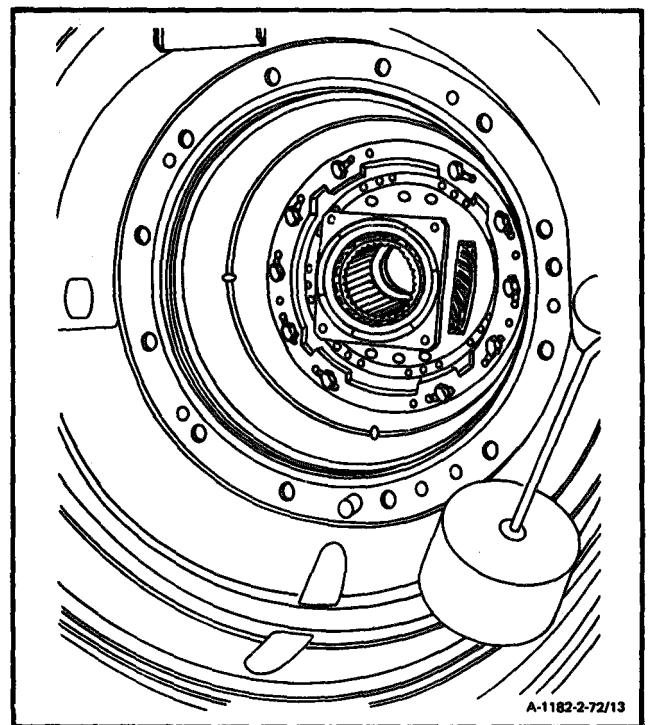
**END OF TASK**

Section XIV. AIR LINES - MAINTENANCE PROCEDURES

2-73 REMOVE HOSE ASSEMBLY (INTERSTAGE AIR-BLEED ACTUATOR TO FUEL CONTROL)

2-73

INITIAL SETUP

Materials:
None

Applicable Configurations:
All

Personnel Required:
68B10 Aircraft Powerplant

Tools:
Powerplant Mechanic's Tool Kit,
NSN 5180-00-323-4944

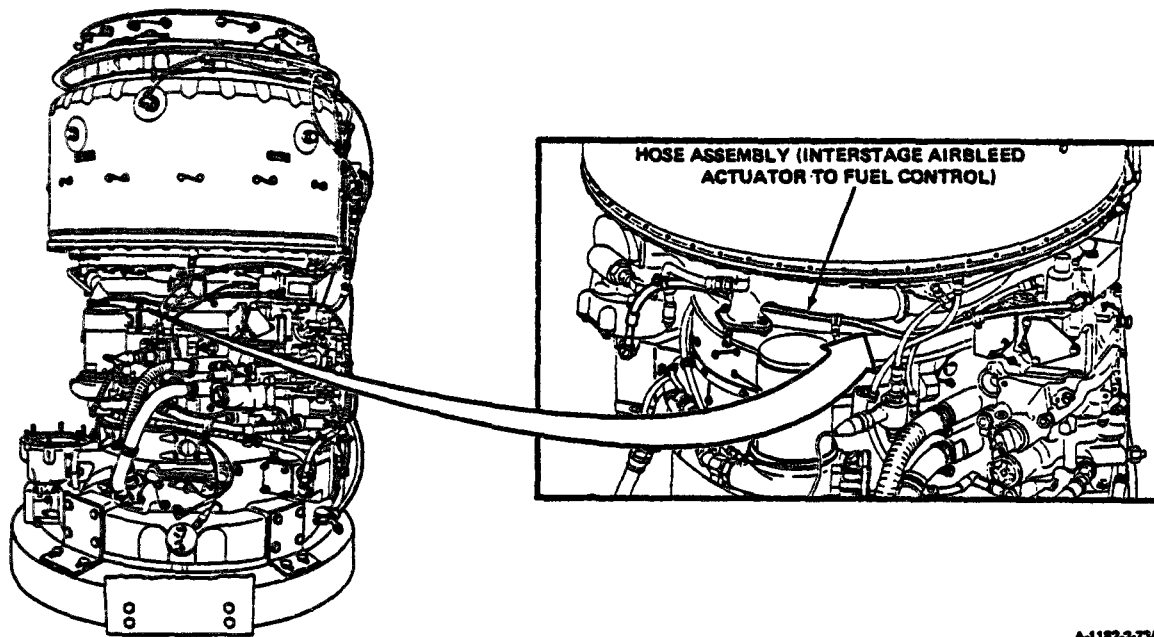

4 x 2

A-1182-3-73/1

GO TO NEXT PAGE

2-73 REMOVE HOSE ASSEMBLY (INTERSTAGE AIR-BLEED ACTUATOR TO FUEL CONTROL) (Continued)

NOTE

For hose assembly without water wash kit P/N 2-200-271-54 installed perform step 1. and omit step 1.1. For hose assembly with water wash kit installed omit step 1. and perform step 1.1.

1. Remove nut (1), screw (2), and clamp (3).

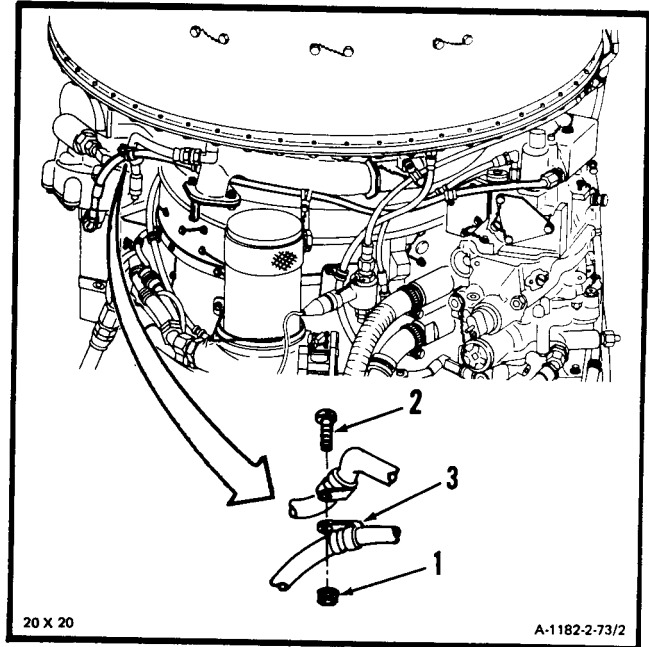

1.1. Remove nut (3.1), screw (3.2) and clamp (3.3).

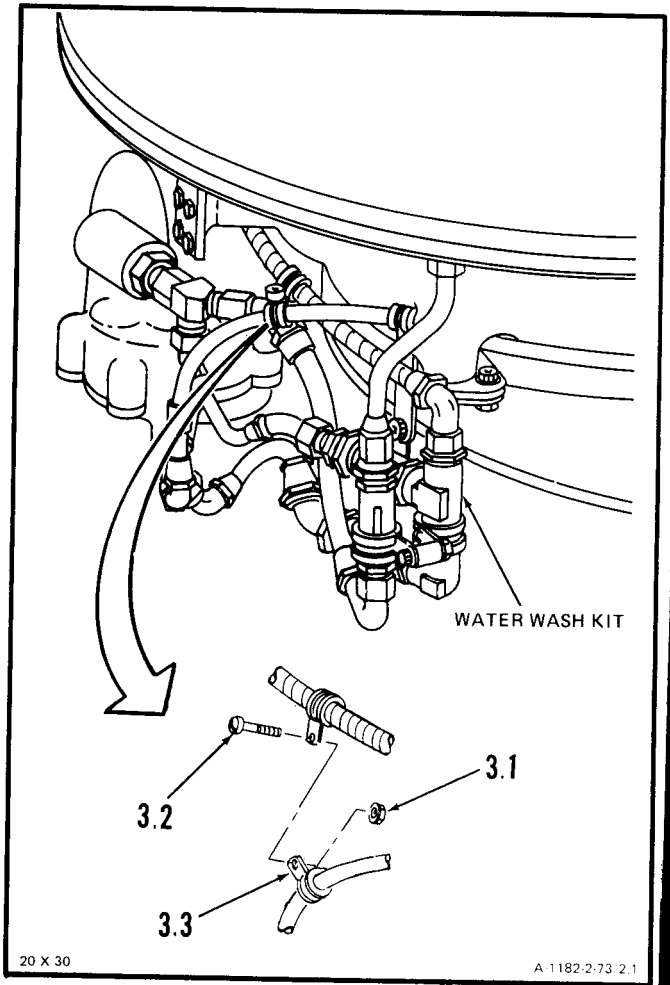

GO TO NEXT PAGE

2-73 REMOVE HOSE ASSEMBLY (INTERSTAGE AIR-BLEED ACTUATOR TO FUEL CONTROL (Continued)

2-73

2. Remove lockwire, two bolts (4), and clamps (5).

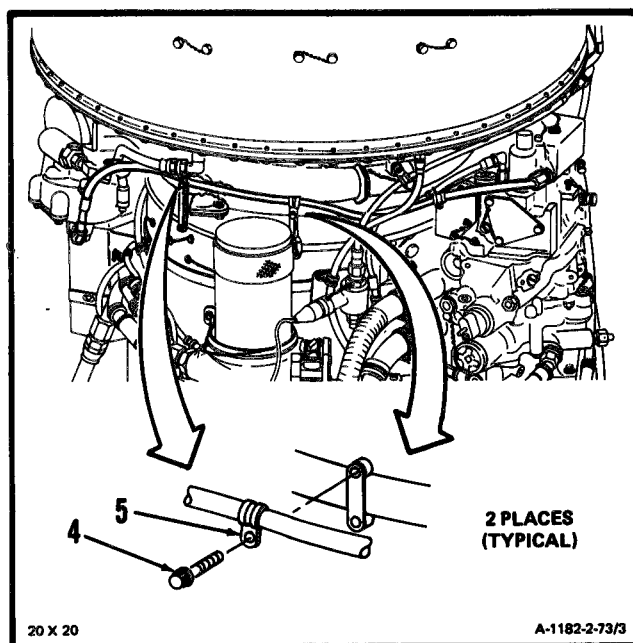

GO TO NEXT PAGE

2-73 REMOVE HOSE ASSEMBLY (INTERSTAGE AIR-BLEED ACTUATOR TO FUEL CONTROL) (Continued)

2-73

3. Remove nut (6), screw (7), and clamp (8).

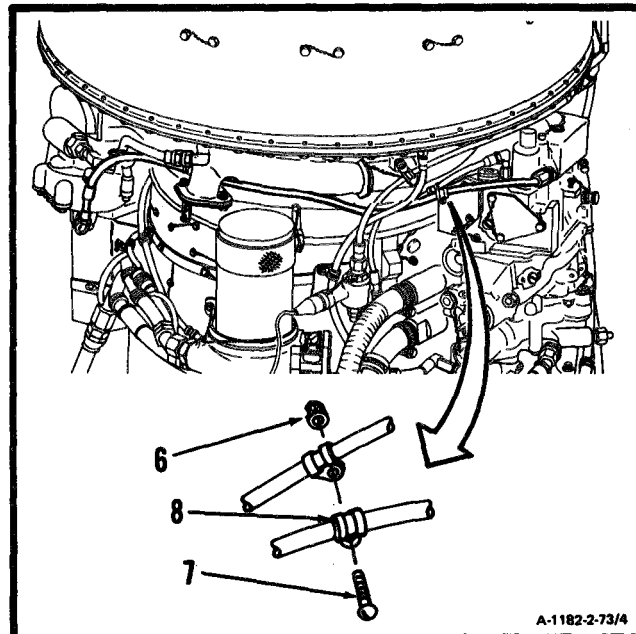

4. Disconnect and remove hose assembly (9).

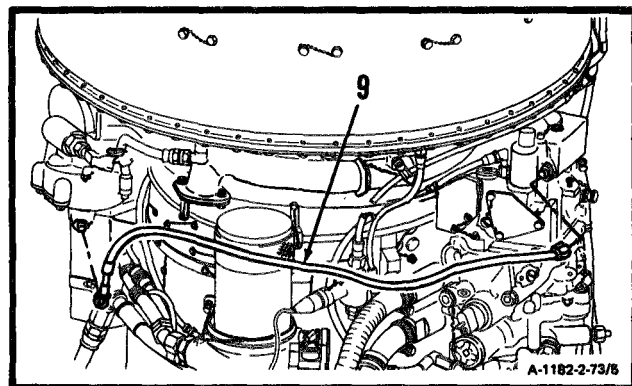

FOLLOW-ON MAINTENANCE:

None

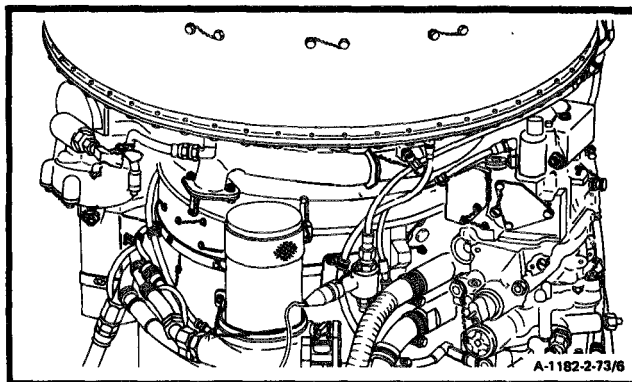

END OF TASK

2-74 INSTALL HOSE ASSEMBLY (INTERSTAGE AIR-BLEED ACTUATOR TO FUEL CONTROL)

2-74

INITIAL SETUP

Applicable Configurations:

All

Tools:

Powerplant Mechanic's Tool Kit,
NSN 5180-00-323-4944

Technical Inspection Tool Kit,
NSN 5180-00-323-5114

Materials:

Lockwire (E29)

Personnel Required:

68B10 Aircraft Powerplant Repairer

68B30 Aircraft Powerplant Inspector

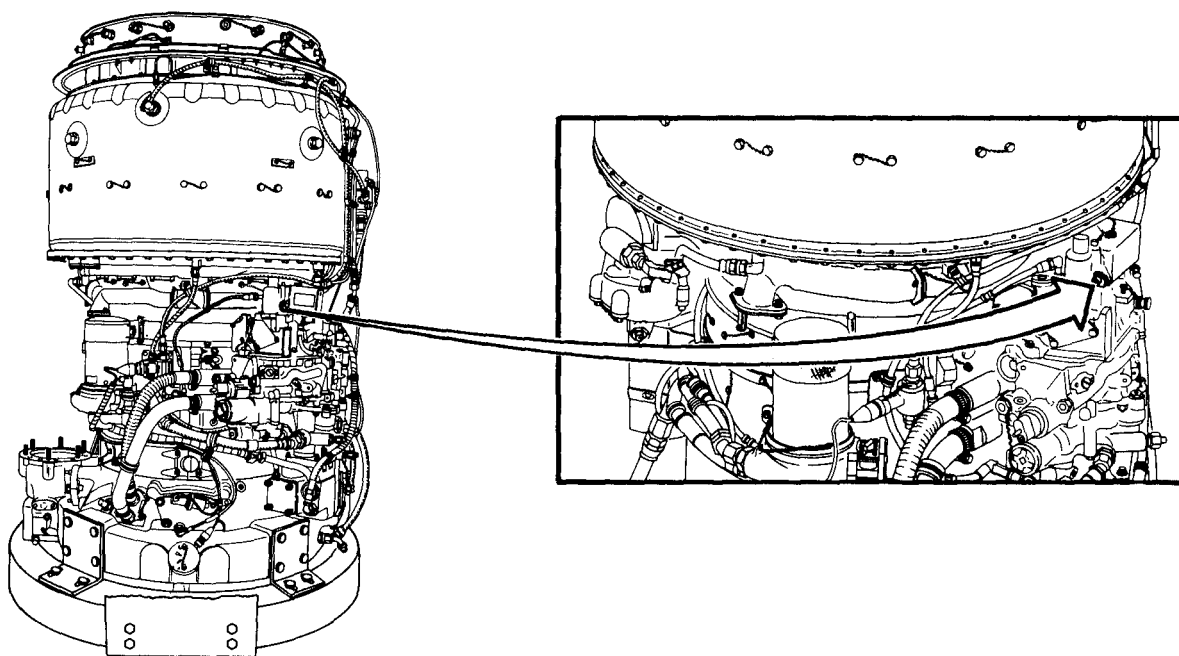

A-1182-2-74/1

GO TO NEXT PAGE

2-74 INSTALL HOSE ASSEMBLY (INTERSTAGE AIR-BLEED ACTUATOR TO FUEL CONTROL) (Continued)

2-74

1. Install hose assembly (1) on nipples (2 and 3).

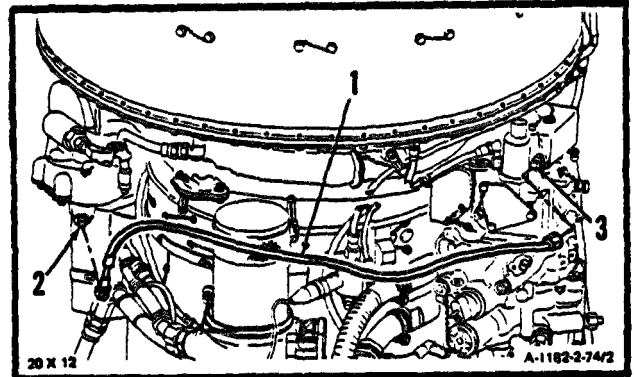

2. Install clamp (4) on hose assembly (1), and install screw (5) and nut (6).

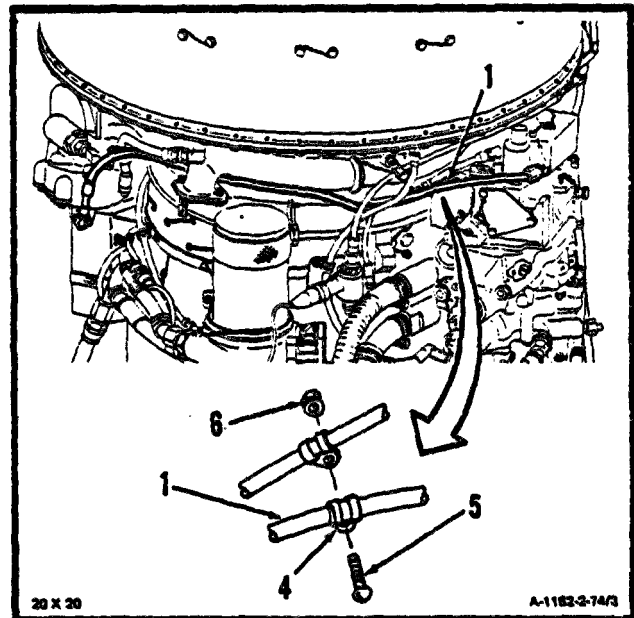
**GO TO NEXT PAGE**

2-74 INSTALL HOSE ASSEMBLY (INTERSTAGE AIR-BLEED ACTUATOR TO FUEL CONTROL) (Continued)

3. **Install two clamps (7)** on hose assembly (1), and install two bolts (8). Lockwire bolts (8). Use lockwire (E29).

NOTE

For hose assembly without water wash kit P/N 2-200-371-54 perform step 4. and omit step 5.
 For hose assembly with water wash kit installed omit step 4. and perform step 5.

4. **Install clamp (9)** on hose assembly (1), and install screw (10) and nut (11).

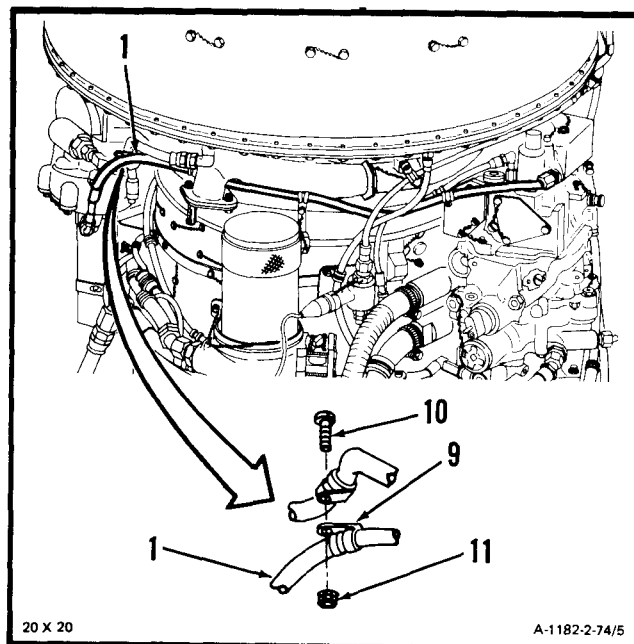
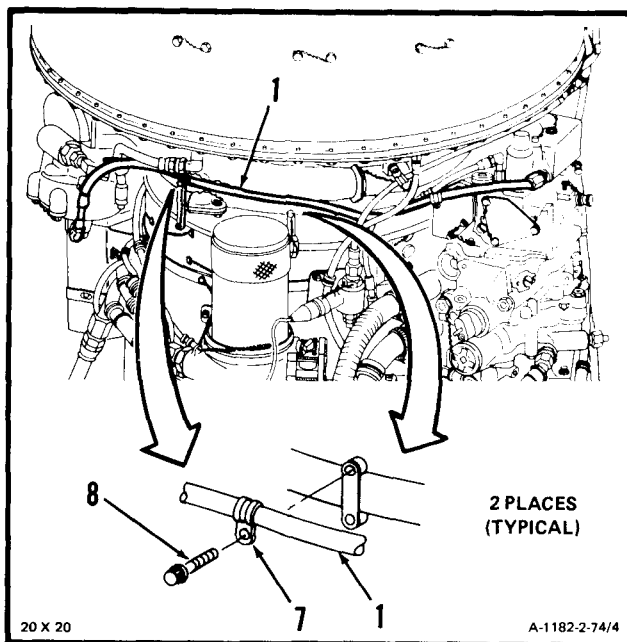

GO TO NEXT PAGE

2-74 INSTALL HOSE ASSEMBLY (INTERSTAGE AIR-BLEED ACTUATOR TO FUEL CONTROL) (Continued)

5. Install clamp (12) on hose assembly (13) and install screw (14) and nut (15).

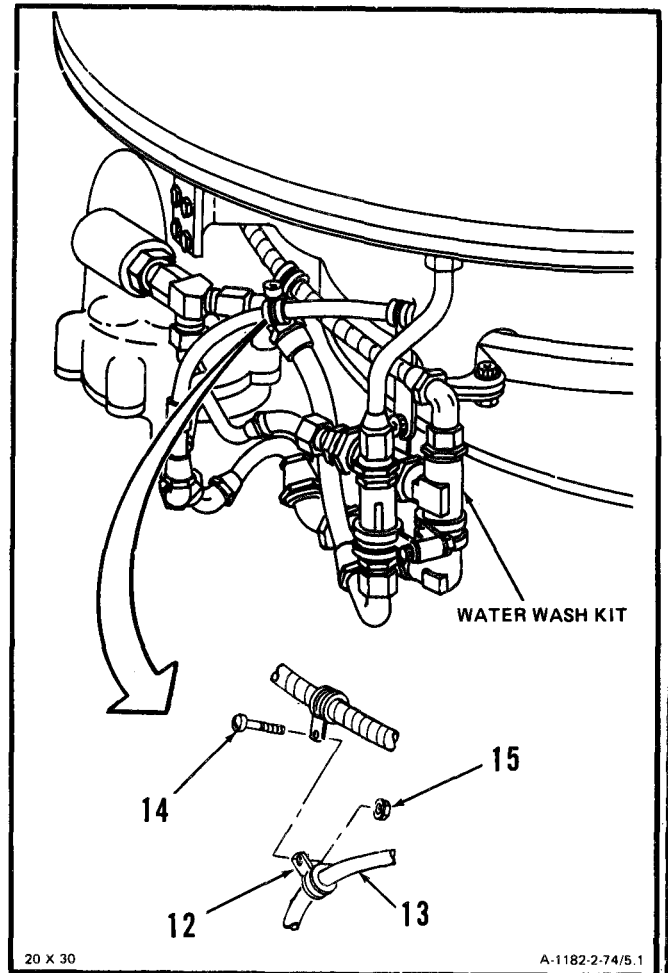

INSPECT

FOLLOW-ON MAINTENANCE:

None

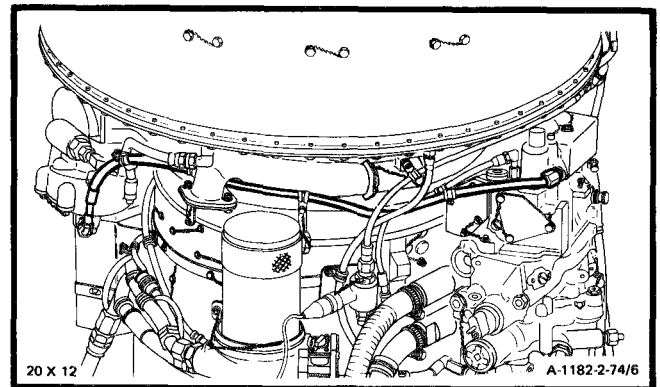

END OF TASK

2-75 REMOVE HOSE ASSEMBLY (INTERSTAGE AIR-BLEED ACTUATOR TO AIR DIFFUSER ASSEMBLY)

2-75

INITIAL SETUP

Materials:

None

Applicable Configurations:

All

Personnel Required:

68B10 Aircraft Powerplant

Tools:

Powerplant Mechanic's Tool Kit,
NSN 5180-00-323-4944

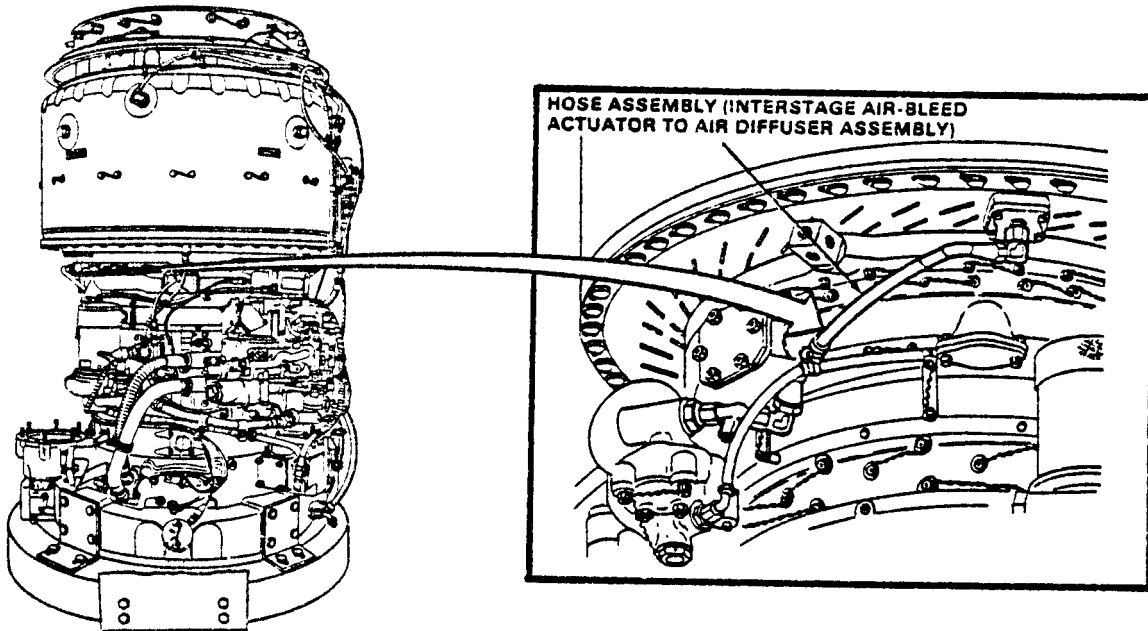

42 x 24

A-1182-2-75/1

GO TO NEXT PAGE

2-75 REMOVE HOSE ASSEMBLY (INTERSTAGE AIR-BLEED ACTUATOR TO AIR DIFFUSER ASSEMBLY) (Continued)

2-75

1. Remove nut (1), screw (2), and clamp (3).

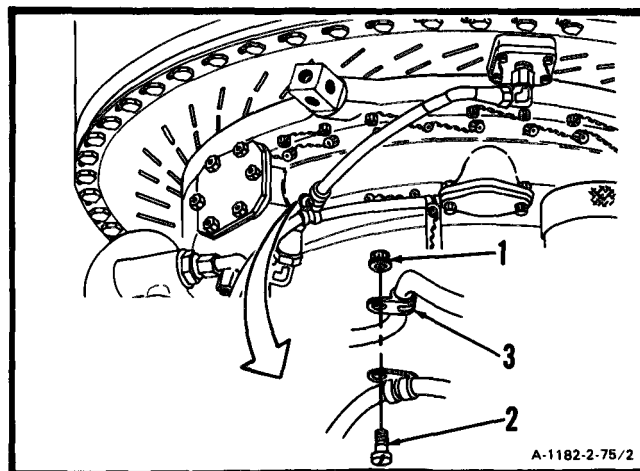

2. Disconnect and remove hose assembly (4).

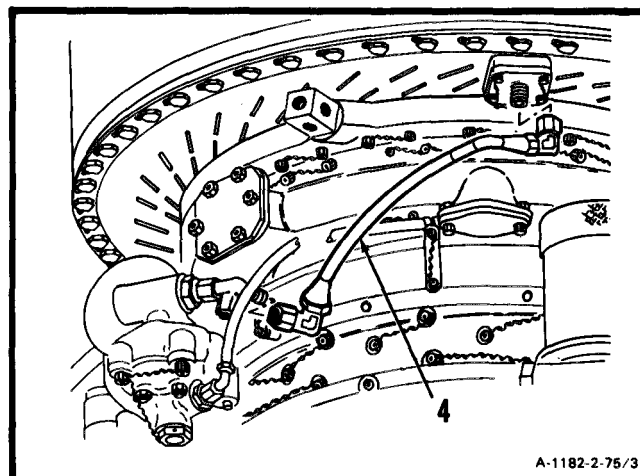

FOLLOW-ON MAINTENANCE:

None

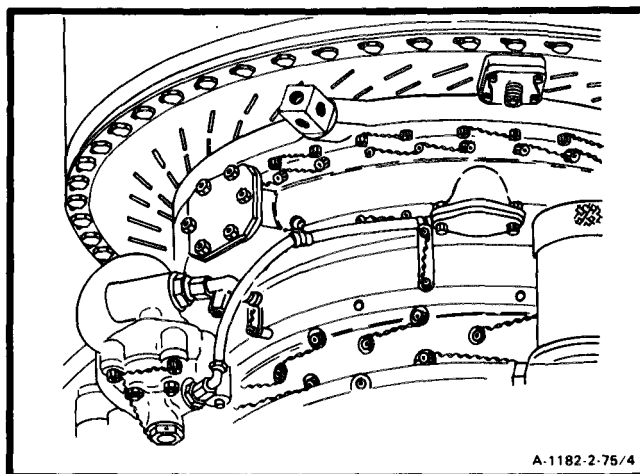

END OF TASK

2-76 INSTALL HOSE ASSEMBLY (INTERSTAGE AIR-BLEED ACTUATOR
TO AIR DIFFUSER ASSEMBLY)

2-76

INITIAL SETUP

Applicable Configurations:

All

Tools:

Powerplant Mechanic's Tool Kit,
NSN 5180-00-323-4944
Technical Inspection Tool Kit,
NSN 5180-00-323-5114

Materials:

None

Personnel Required:

68610 Aircraft Powerplant Repairer
68630 Aircraft Powerplant Inspector

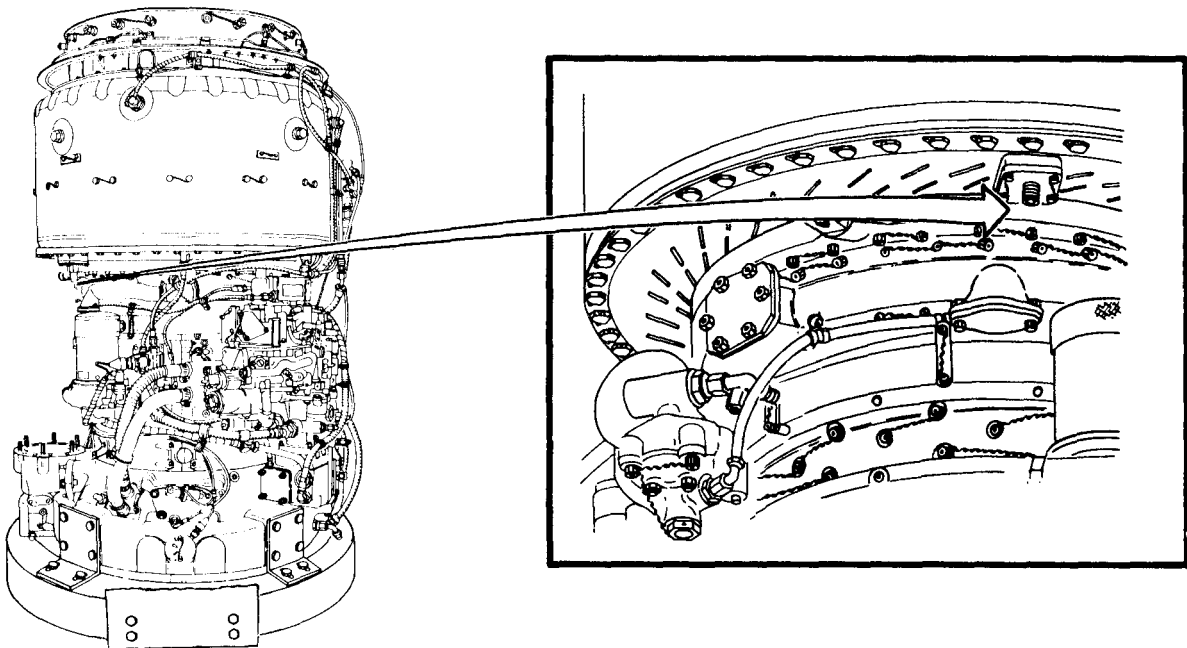

A-1182-2-76/1

GO TO NEXT PAGE

2-76 INSTALL HOSE ASSEMBLY (INTERSTAGE AIR-BLEED ACTUATOR TO AIR DIFFUSER ASSEMBLY) (Continued)

2-76

1. Install hose assembly (1) on tee (2) and adapter (3).

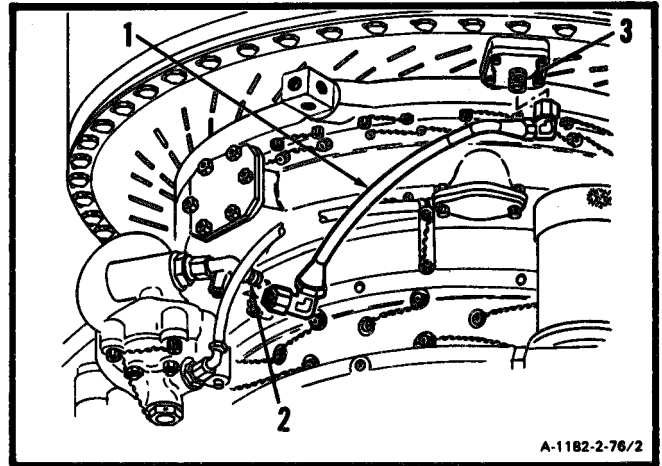

A-1182-2-76/2

2. Install damp (4) on hose assembly (1) and install screw (5) and nut (6).

INSPECT

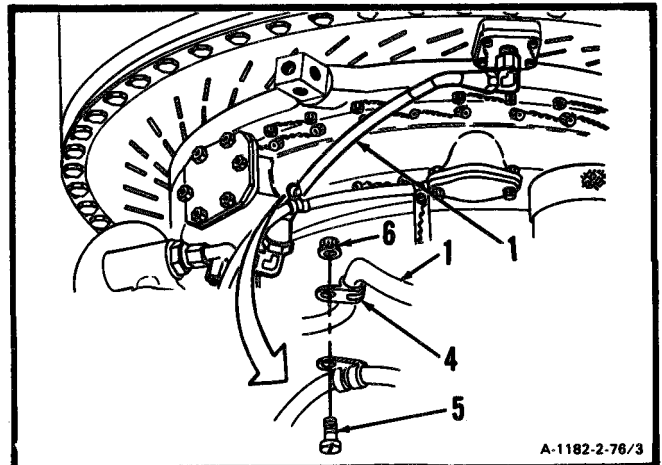

A-1182-2-76/3

FOLLOW-ON MAINTENANCE:

None

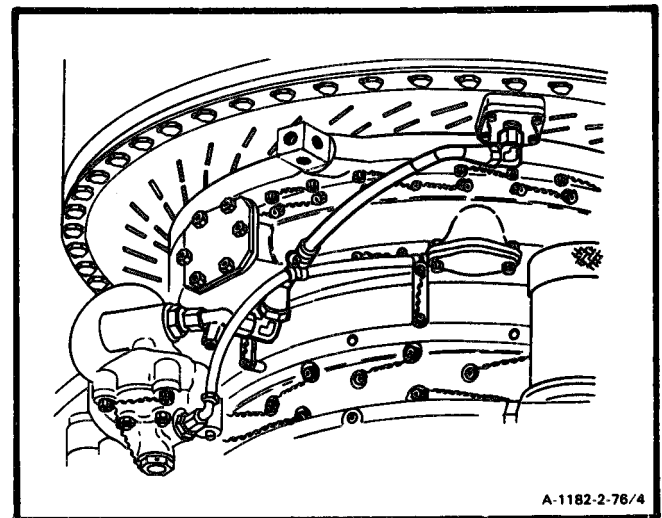

A-1182-2-76/4

END OF TASK

2-77 REMOVE HOSE ASSEMBLY (COMPRESSOR HOUSING TO
INLET HOUSING)

2-77

INITIAL SETUP

Applicable Configurations:

All

Tools:

Powerplant Mechanic's Tool Kit,
NSN 5180-00-323-4944

Materials:

None

Personnel Required:

68B10 Aircraft Powerplant Repairer

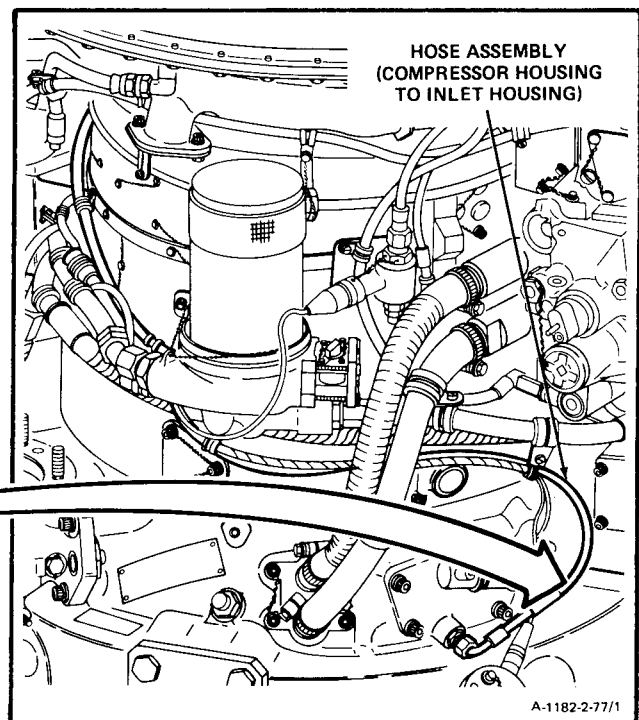
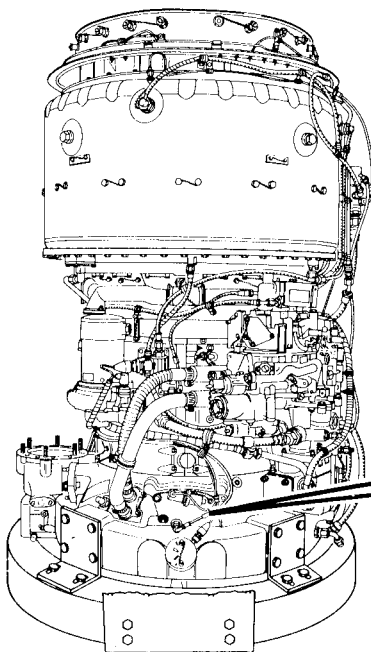

GO TO NEXT PAGE

**2-77 REMOVE HOSE ASSEMBLY (COMPRESSOR HOUSING TO
INLET HOUSING) (Continued)**

2-77

1. Remove nut (1), screw (2), and clamp (3).

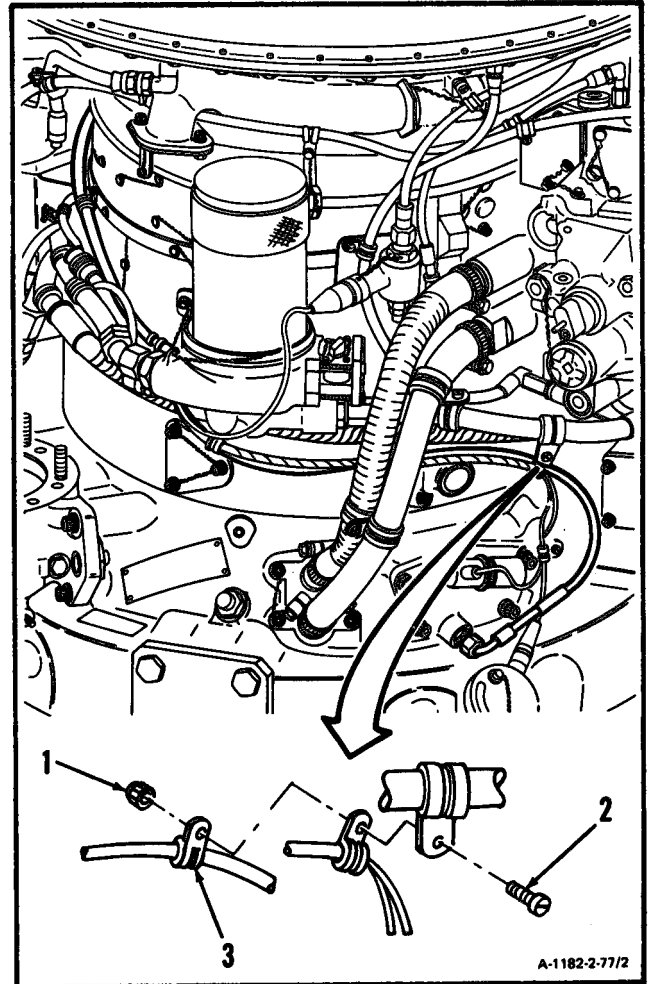

GO TO NEXT PAGE

2-77 REMOVE HOSE ASSEMBLY (COMPRESSOR HOUSING TO INLET HOUSING) (Continued)

2. Remove nut (4), screw (5), and clamp (6).

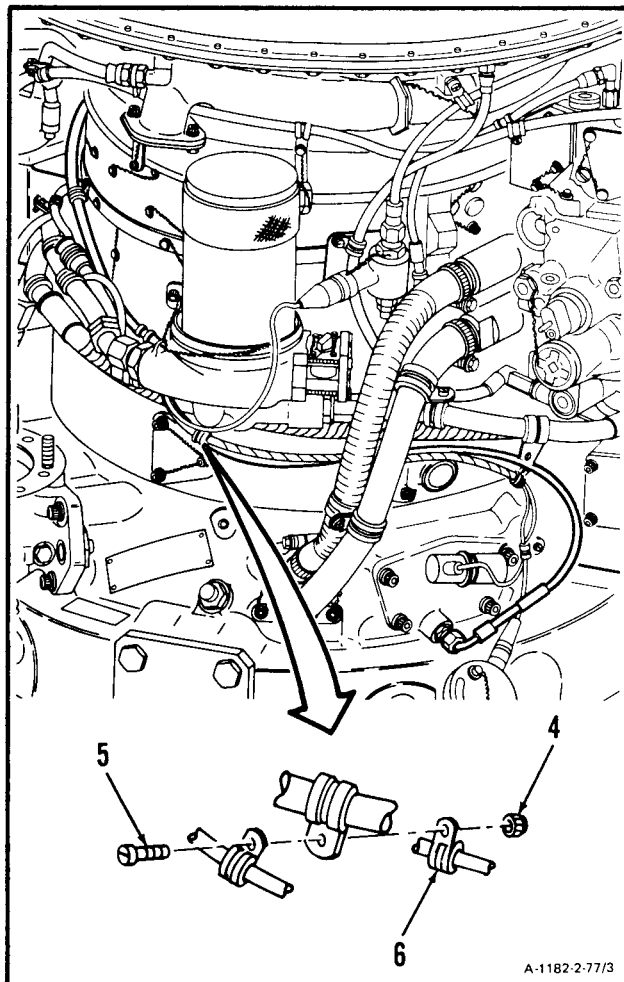

GO TO NEXT PAGE

2-77 REMOVE HOSE ASSEMBLY (COMPRESSORHOUSING TO INLET HOUSING) (Continued)

2-77

3. Remove nut (7), screw (8), and clamp (9).

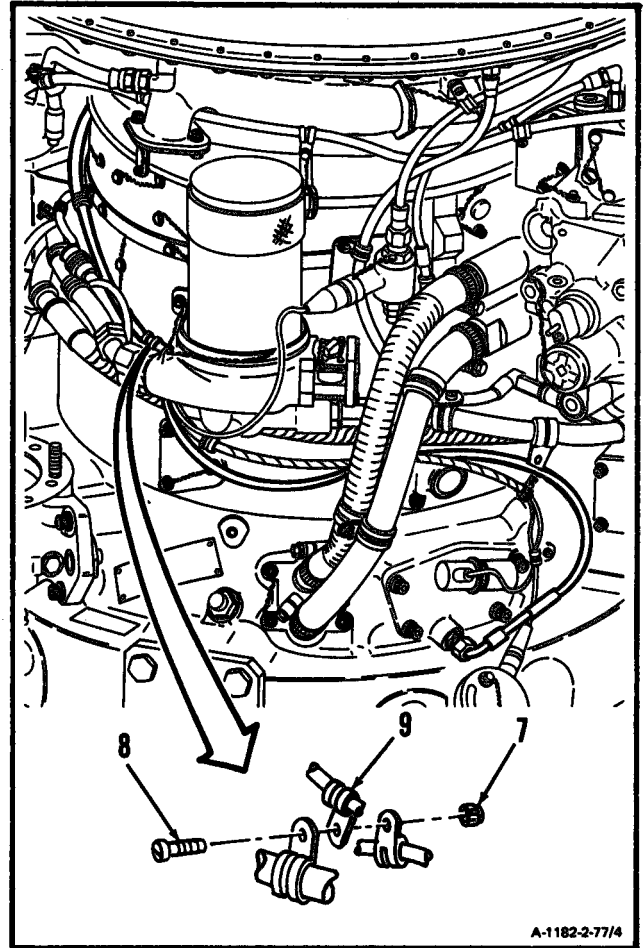

A-1182-2-77/4

GO TO NEXT PAGE

2-77 REMOVE HOSE ASSEMBLY (COMPRESSOR HOUSING TO INLET HOUSING) (Continued)

4. Remove lockwire, screw (10) and clamp (11).

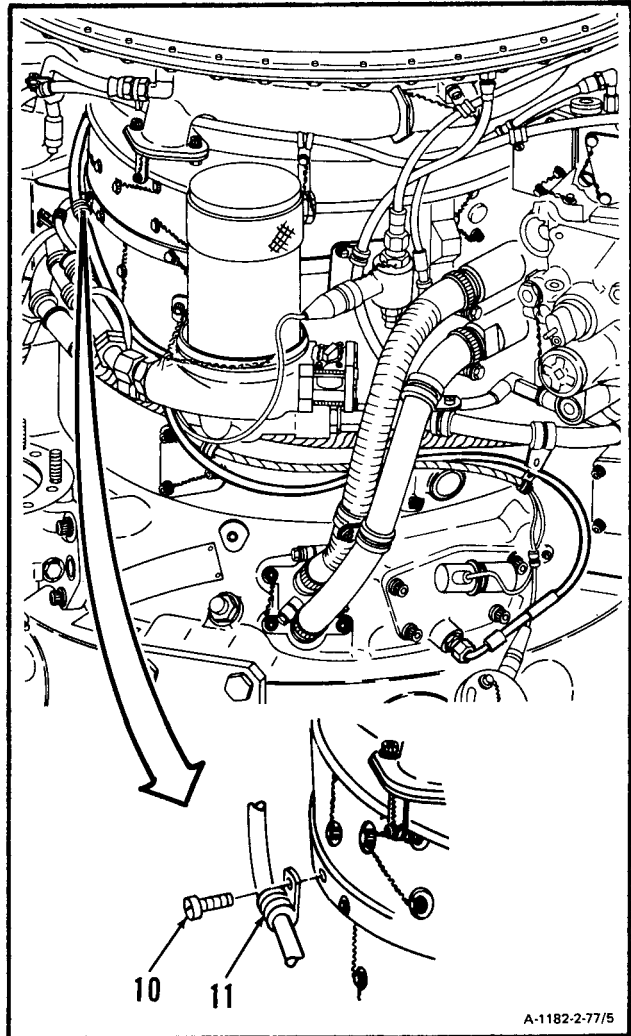

GO TO NEXT PAGE

2-77 REMOVE HOSE ASSEMBLY (COMPRESSOR HOUSING TO INLET HOUSING) (Continued)

2-77

5. Disconnect and remove hose assembly (12).

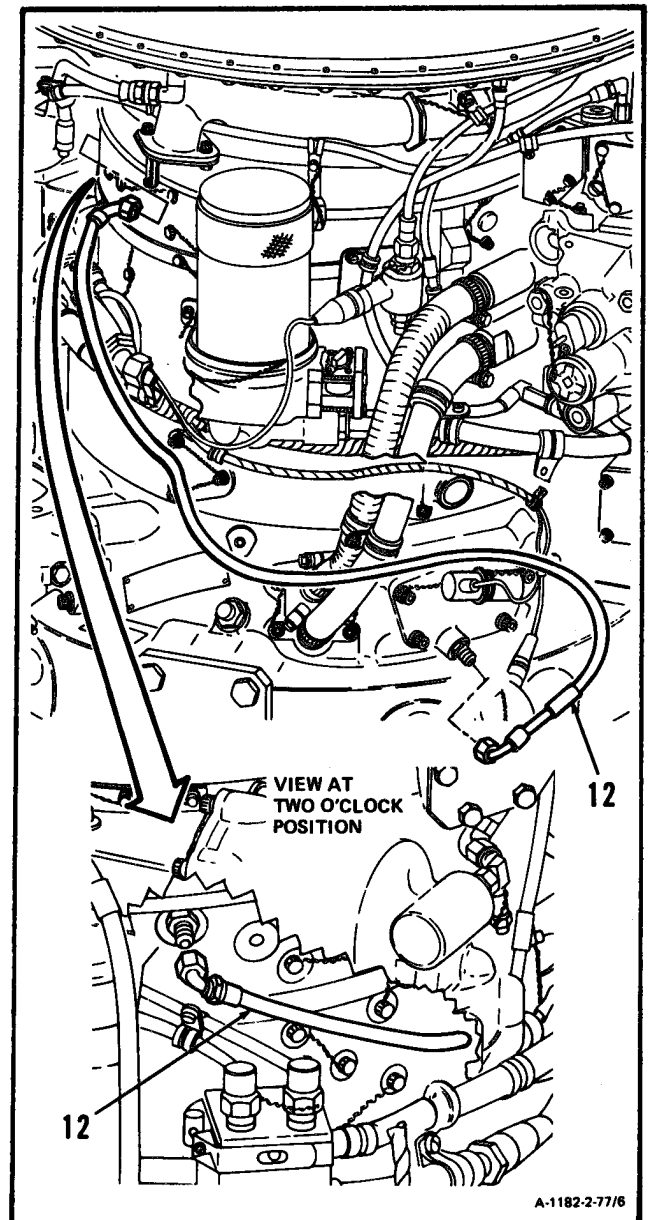

GO TO NEXT PAGE

2-77 REMOVE HOSE ASSEMBLY (COMPRESSOR HOUSING TO
INLET HOUSING) (Continued)

2-77

FOLLOW-ON MAINTENANCE:

None

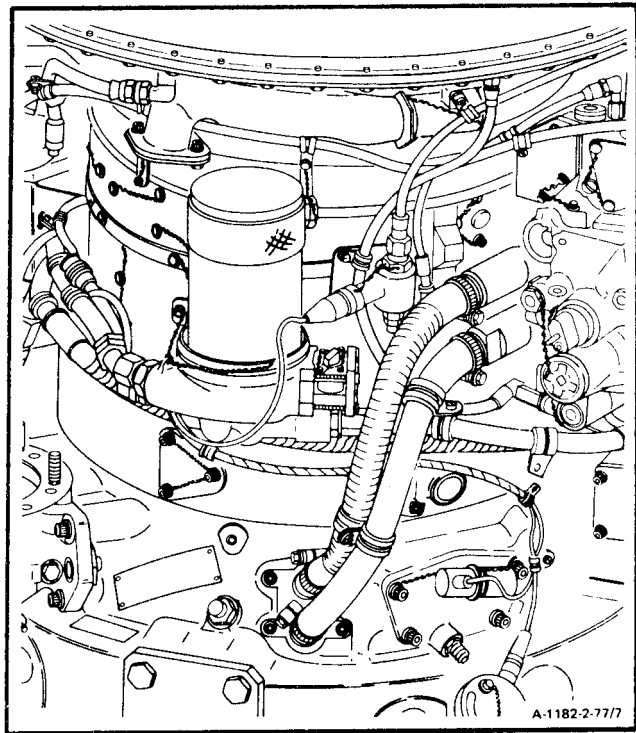

END OF TASK

**2-78 INSTALL HOSE ASSEMBLY (COMPRESSOR HOUSING TO
INLET HOUSING)**

2-78

INITIAL SETUP**Applicable Configurations:**

All

Tools:

Powerplant Mechanic's Tool Kit,
NSN 5180-00-323-4944
Technical inspection Tool Kit,
NSN 5180-00-323-5114

Materials:

Lockwire (E29)

Personnel Required:

68610 Aircraft Powerplant Repairer
68B30 Aircraft Powerplant Inspector

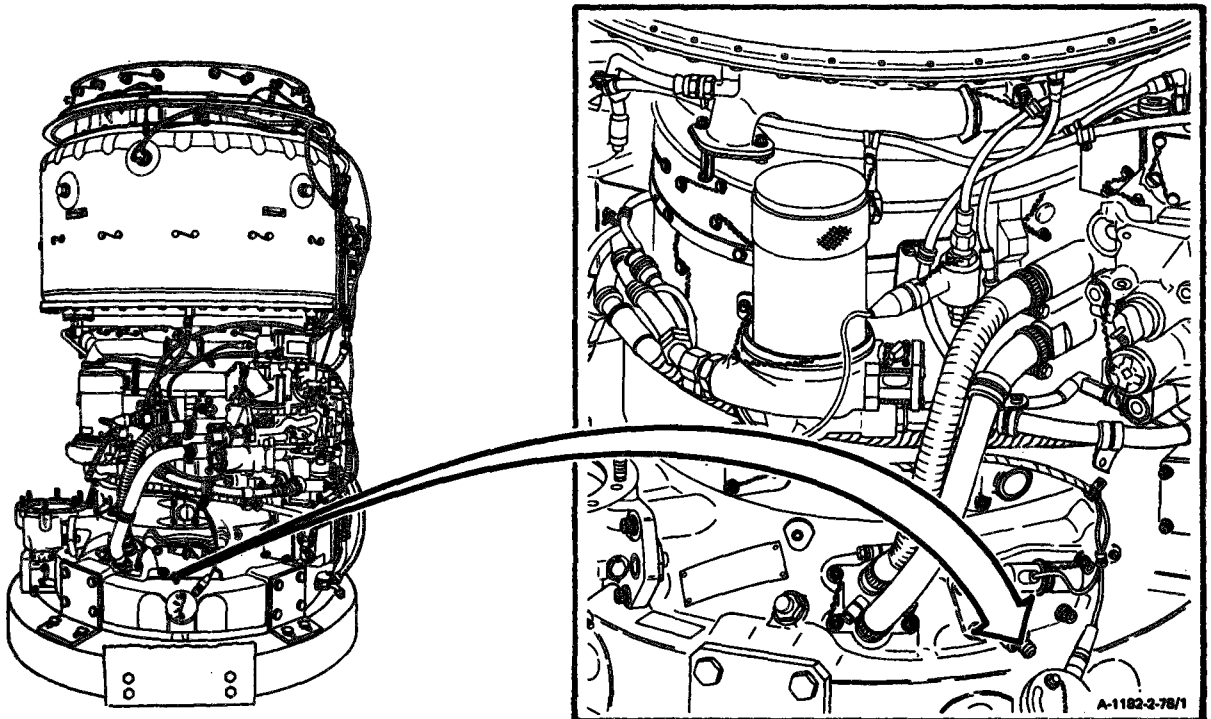
**GO TO NEXT PAGE**

2-78 INSTALL HOSE ASSEMBLY (COMPRESSOR HOUSING TO
INLET HOUSING) (Continued)

2-78

1. Install hose assembly (1) on nipples (2 and 3).

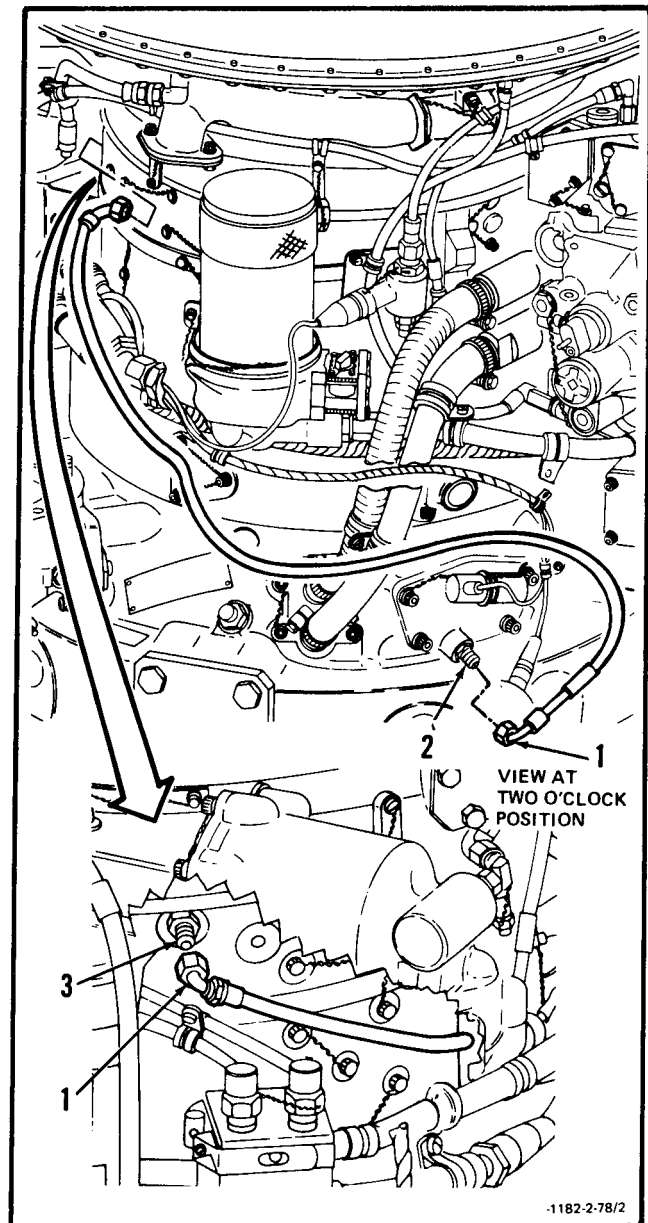

GO TO NEXT PAGE

2-78 INSTALL HOSE ASSEMBLY (COMPRESSOR HOUSING TO INLET HOUSING) (Continued)

2-78

2. **Install clamp (4)** on hose assembly (1), and install screw (5). Lockwire screw (5). Use lockwire (E29).

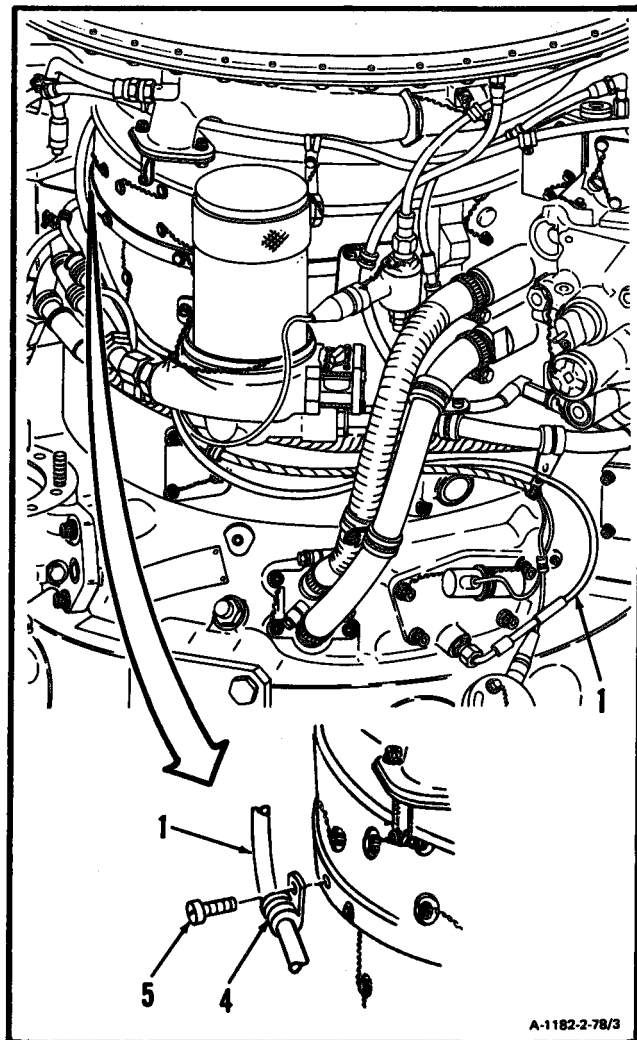
**GO TO NEXT PAGE**

2-78 INSTALL HOSE ASSEMBLY (COMPRESSOR HOUSING TO INLET HOUSING) (Continued)

2-78

3. **Install clamp (6)** on hose assembly (1), and install screw (7) and nut (8).

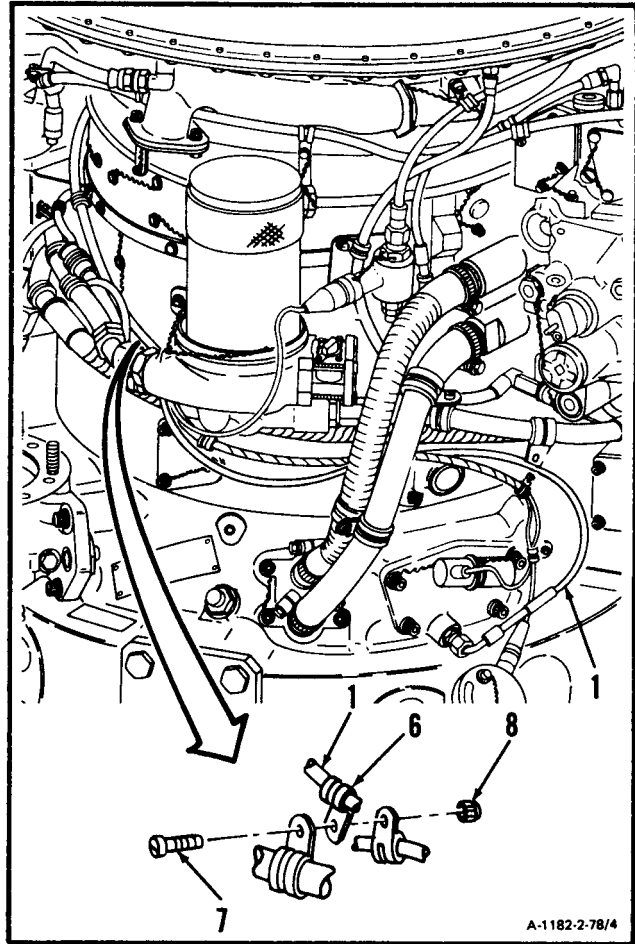
**GO TO NEXT PAGE**

2-78 INSTALL HOSE ASSEMBLY (COMPRESSOR HOUSING TO INLET HOUSING) (Continued)

2-78

4. **Install clamp (9)** on hose assembly (1), and install screw (10) and nut (11).

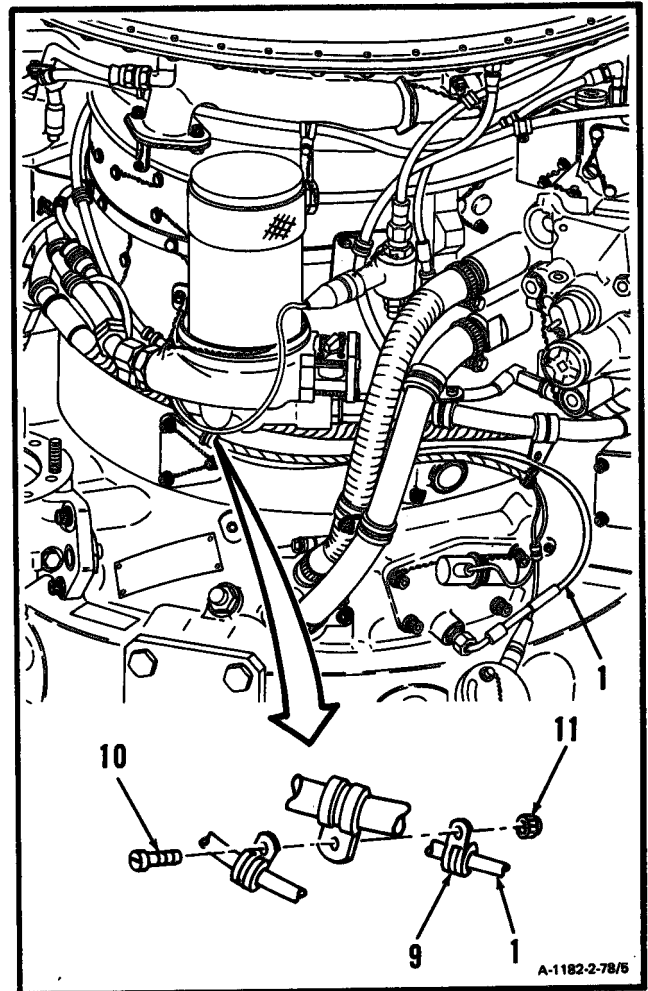

GO TO NEXT PAGE

2-78 INSTALL HOSE ASSEMBLY (COMPRESSOR HOUSING TO INLET HOUSING) (Continued)

5. **Install clamp (12)** on hose assembly (1), and install screw (13) and nut (14).

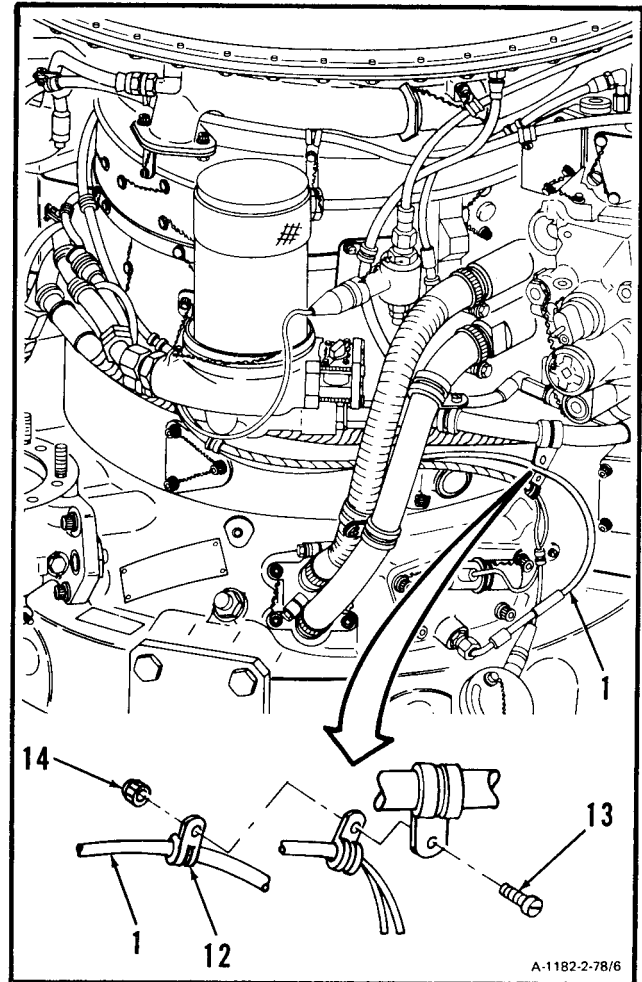

INSPECT

GO TO NEXT PAGE

**2-78 INSTALL HOSE ASSEMBLY (COMPRESSOR HOUSING TO
INLET HOUSING) (Continued)**

2-7%

FOLLOW-ON MAINTENANCE:

None

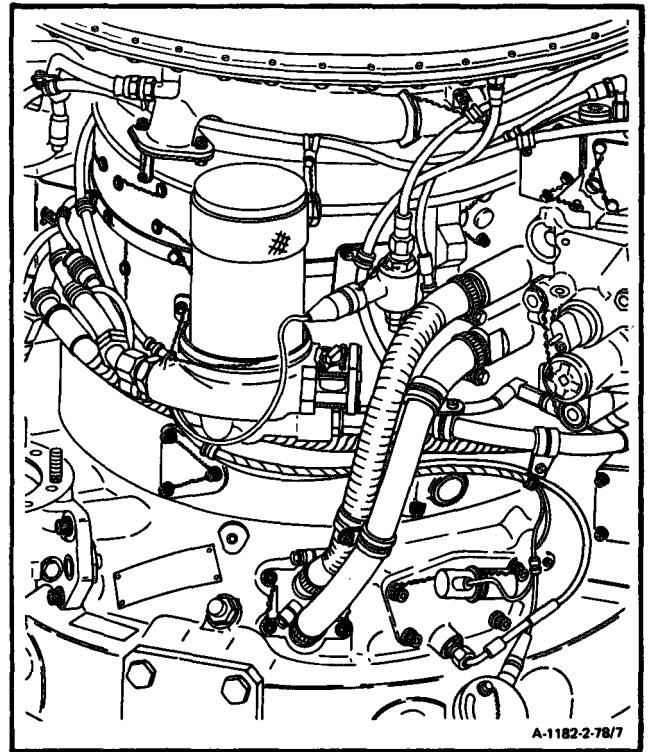
**END OF TASK**

2-79 REMOVE HOSE ASSEMBLY (AIR DIFFUSER ASSEMBLY TO FUEL CONTROL)

2-79

INITIAL SETUP

Applicable Configurations:

All

Tools:

Powerplant Mechanic's Tool Kit,
NSN 5180-00-323-4944

Materials:

None

Personnel Required:

68B10 Aircraft Powerplant Repairer

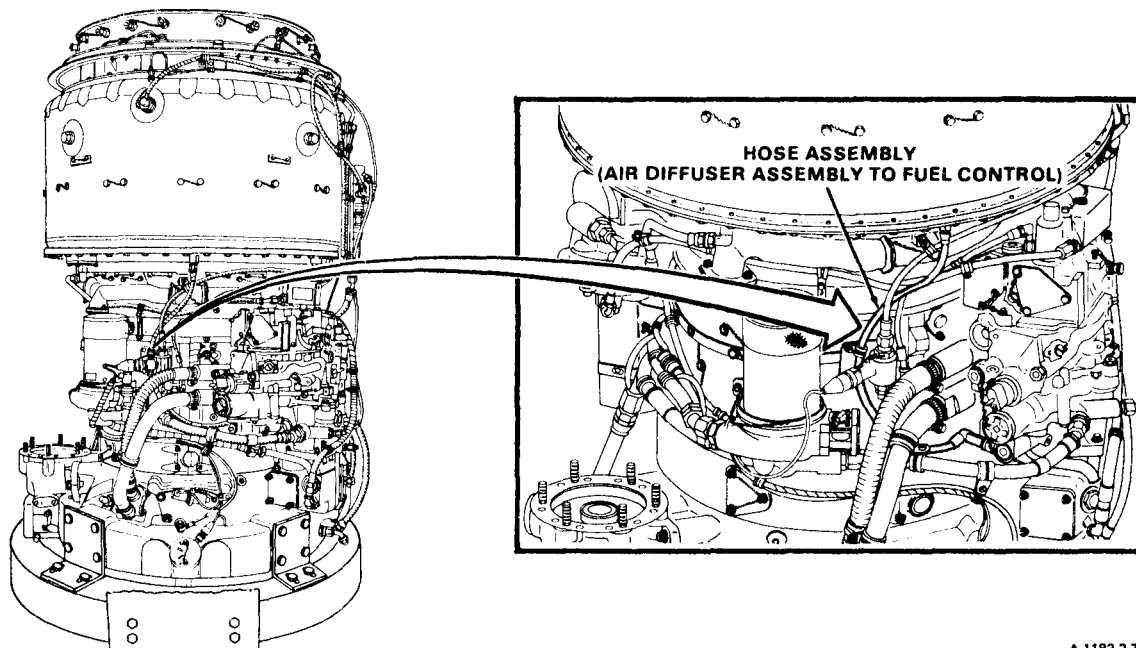

A-1182-2-79/1

GO TO NEXT PAGE

 2-79 REMOVE HOSE ASSEMBLY (AIR DIFFUSER ASSEMBLY TO FUEL CONTROL) (Continued)

2-79

1. **Remove** nuts (1), screws (2), and **clamps** (3).

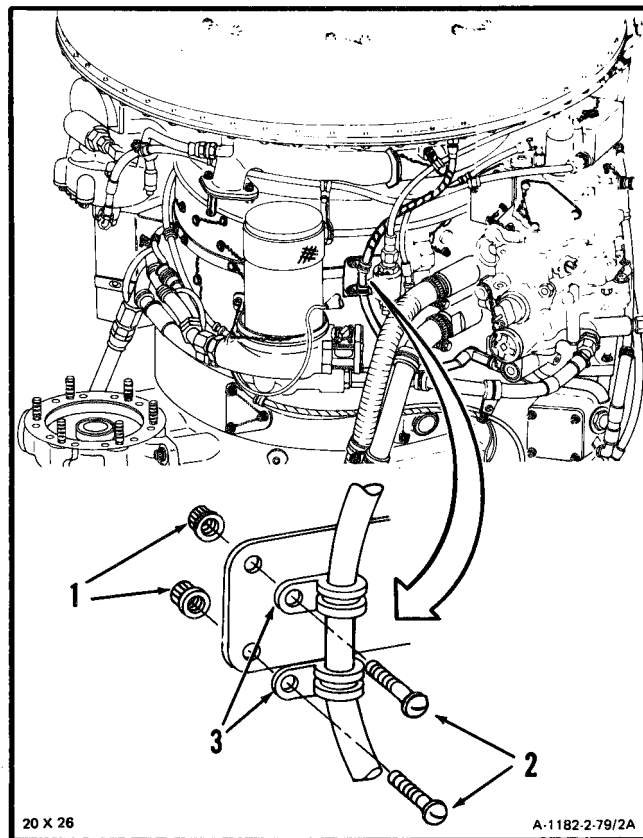
**NOTE**

If lockwire securing bolts on union is disturbed when disconnecting hose in following step, remove lockwire.

2. **Disconnect and remove** hose assembly (4).

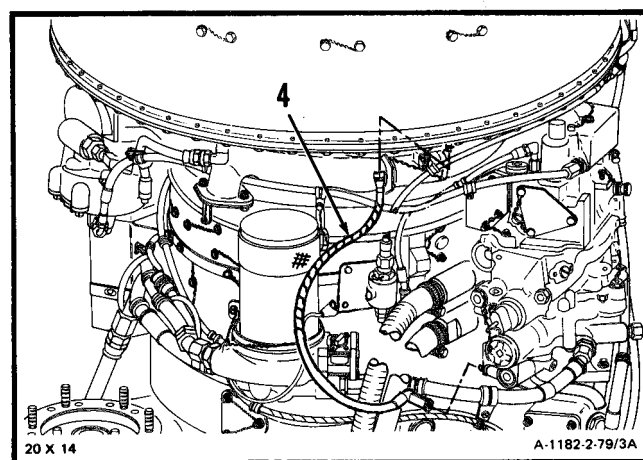

GO TO NEXT PAGE

2-79 REMOVE HOSE ASSEMBLY (AIR DIFFUSER ASSEMBLY TO FUEL CONTROL) (Continued)

2-79

FOLLOW-ON MAINTENANCE:

None

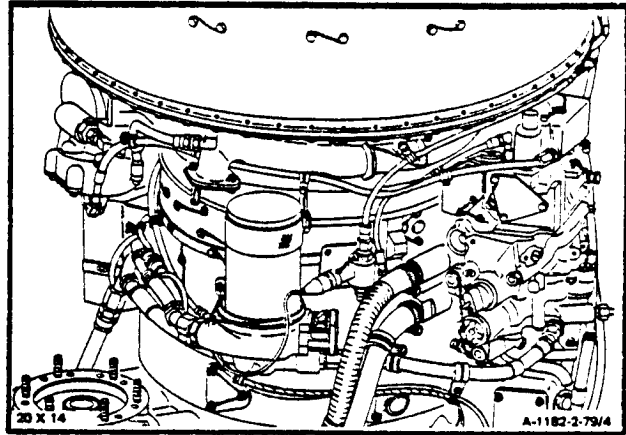

END OF TASK

2-80 INSTALL HOSE ASSEMBLY (AIR DIFFUSER ASSEMBLY TO FUEL CONTROL)

2-80

INITIAL SETUP**Applicable Configurations:**

All

Tools:

Powerplant Mechanic's Tool Kit,
NSN 5180-00-323-4944
Technical Inspection Tool Kit,
NSN 5180-00-323-5114

Materials:

None

Personnel Required:

68B10 Aircraft Powerplant Repairer
68B30 Aircraft Powerplant Inspector

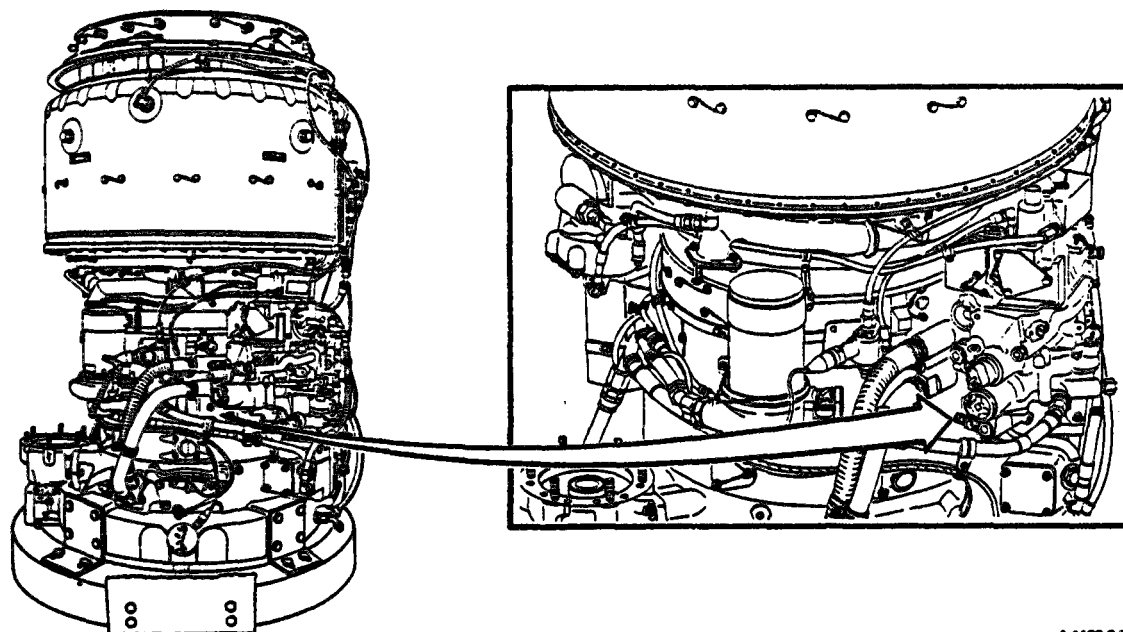
**GO TO NEXT PAGE**

NOTE

If required, install lockwire on bolts securing union after connecting hose in following step. Use lockwire (E29).

1. **Install hose assembly (1)** on union (2) and nipple (3).

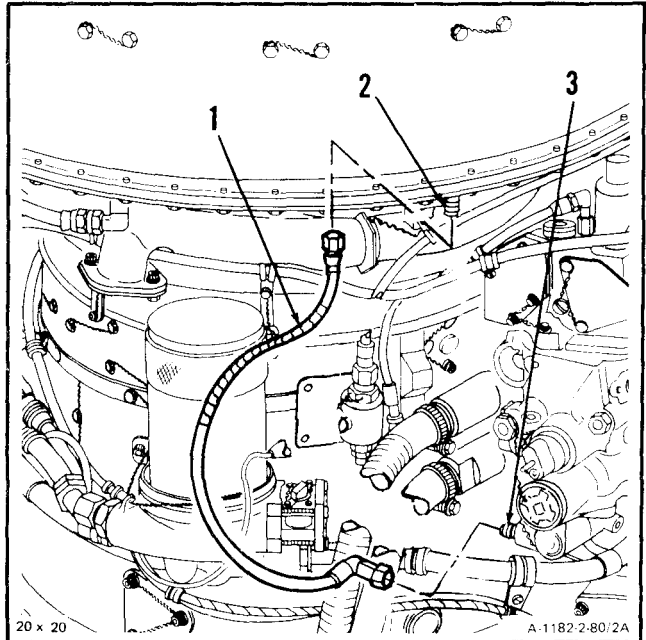

2. **Install clamps (4)** on hose assembly (1) and install screws (5) and nuts (6).

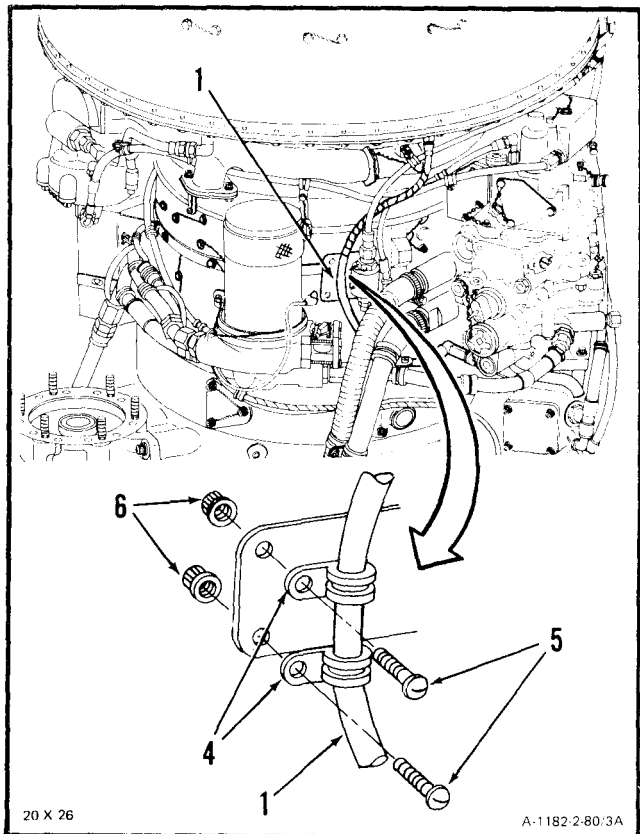

INSPECT

GO TO NEXT PAGE

2-80 INSTALL HOSE ASSEMBLY (AIR DIFFUSER ASSEMBLY TO FUEL CONTROL) (Continued)

2-80

FOLLOW-ON MAINTENANCE:

None

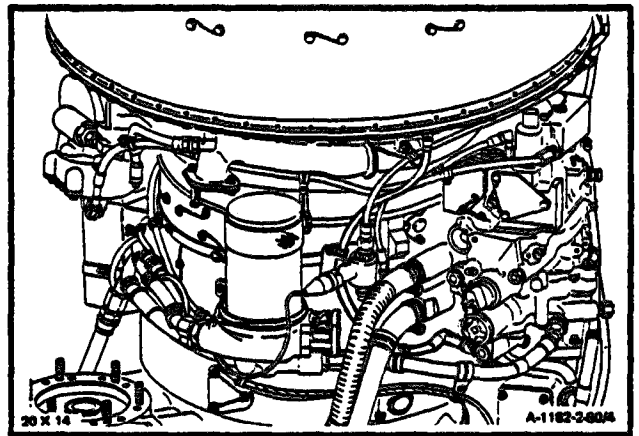
**END OF TASK**

2-80.1 REMOVE TUBE ASSEMBLY (AIR DIFFUSER ASSEMBLY TO WATER WASH CHECK VALVE)

2-80.1

INITIAL SETUP

Applicable Configurations:

All

Tools:

Powerplant Mechanic's Tool Kit,
NSN 5180-00-323-4944

Materials:

None

Personnel Required:

68B30 Aircraft Powerplant Repairer

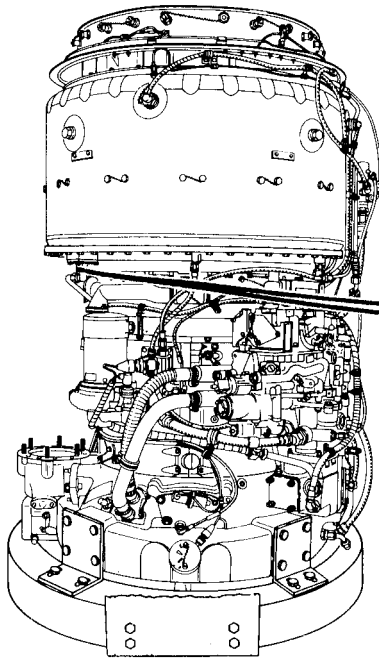

42 X 24

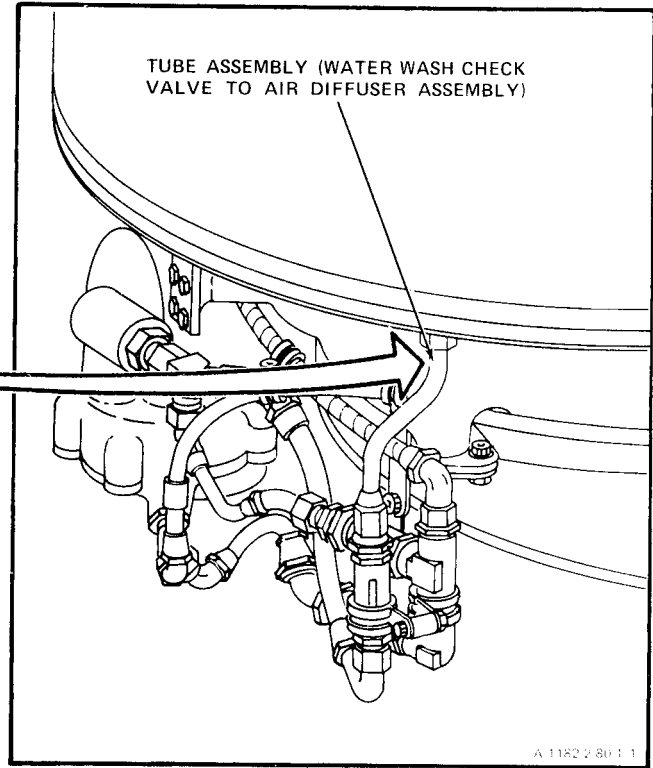

A 1182 2 80 1 1

GO TO NEXT PAGE

2-80.1 REMOVE TUBE ASSEMBLY (AIR DIFFUSER ASSEMBLY TO WATER WASH 2-80.1 CHECK VALVE) (Continued)

1. Disconnect and remove hose assembly (1).

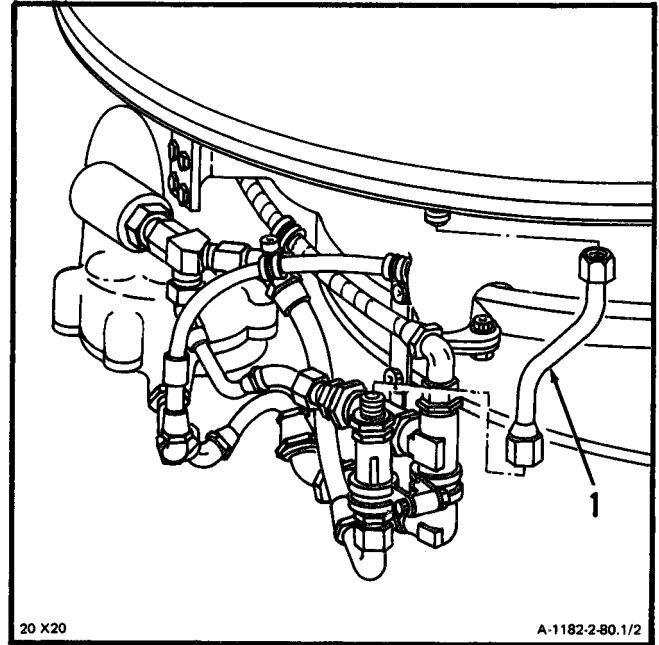

FOLLOW-ON MAINTENANCE:

None

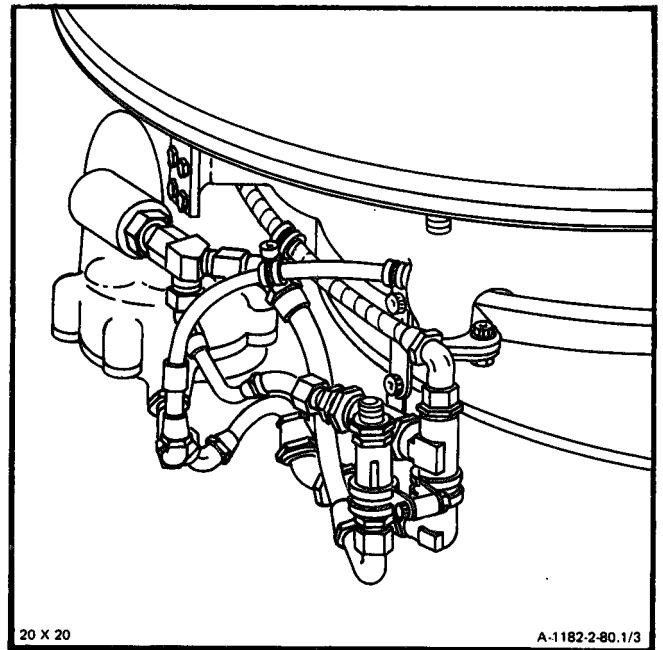

END OF TASK

2-80.2 INSTALL TUBE ASSEMBLY (AIR DIFFUSER ASSEMBLY TO WATER WASH CHECK VALVE)

2-80.2

INITIAL SETUP

Materials:

None

Applicable Configurations:

All

Personnel Required:

68B10 Aircraft Powerplant Repairer

68B13 Aircraft Powerplant Inspector

Tools:

Powerplant Mechanic's Tool Kit,

NSN 5180-00-323-4944

Technical Inspection Tool Kit,

NSN 5180-00-323-5114

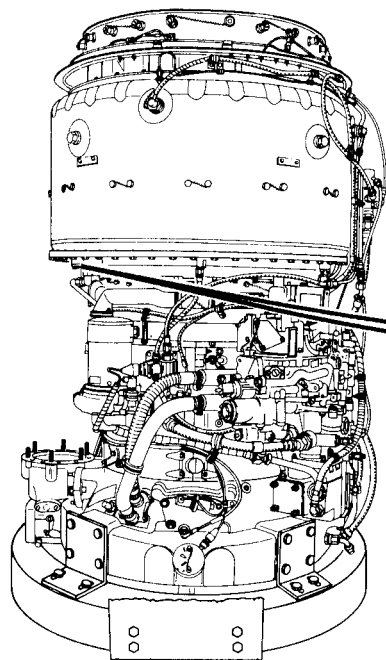

40 X 24

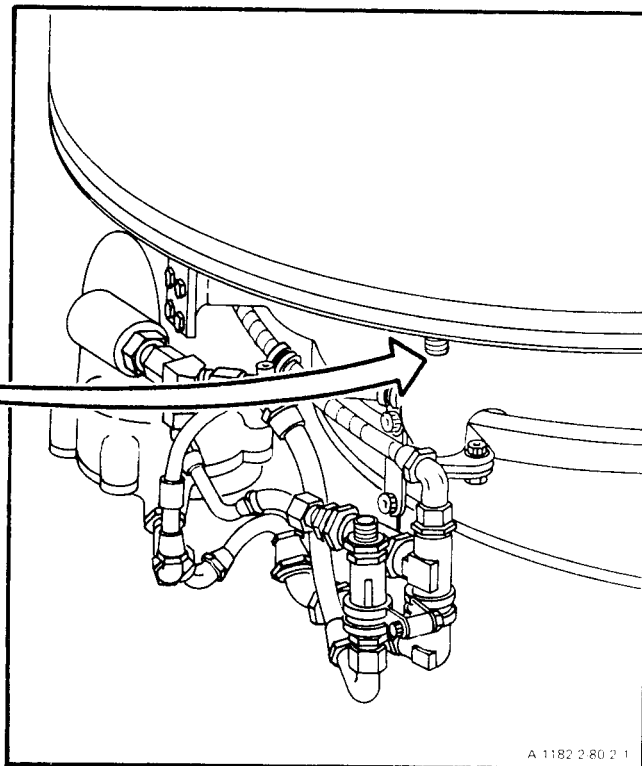

A 1182 2.80 2 1

GO TO NEXT PAGE

2-80.2 INSTALL TUBE ASSEMBLY (AIR DIFFUSER ASSEMBLY TO WATER WASH CHECK VALVE) (Continued)

2.80.1

1. Install hose assembly (1) on air diffuser P3 adapter (2) and nipple (3).

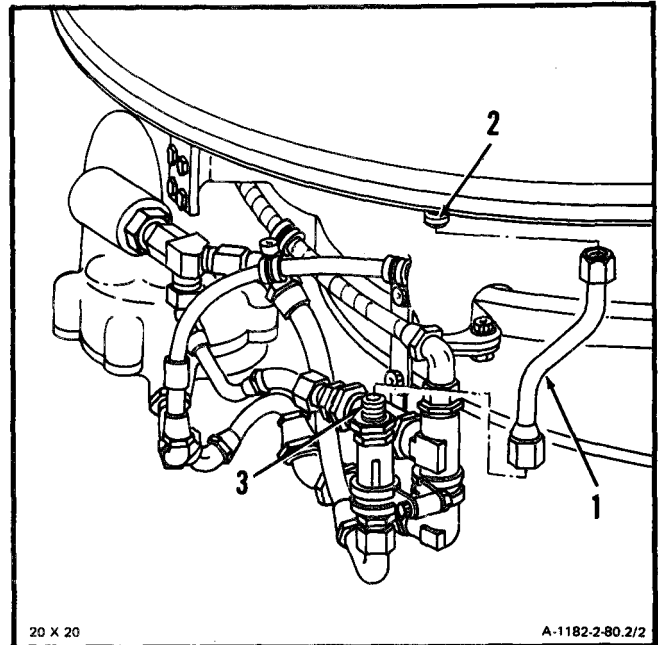

INSPECT

FOLLOW-ON MAINTENANCE:

None

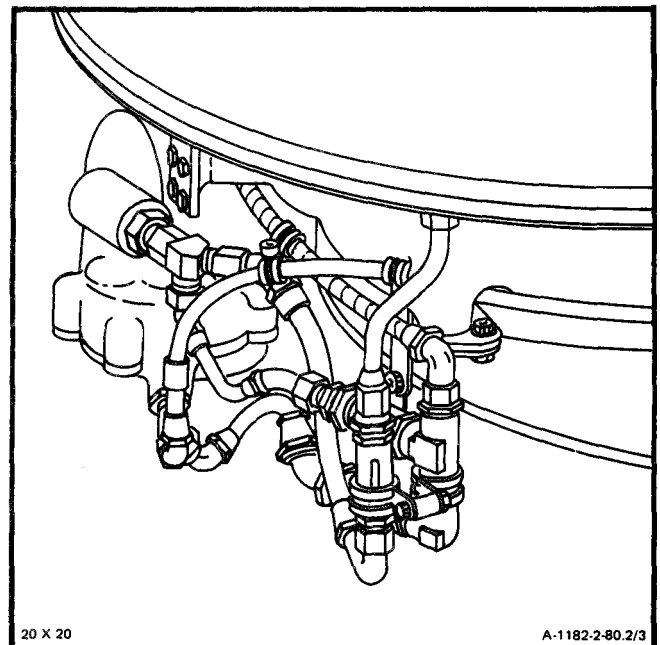

END OF TASK

2-80.3 REMOVE HOSE ASSEMBLY (WATER WASH CHECK VALVE TO INTERSTAGE AIR-BLEED ACTUATOR P3 INLET)

2-80.3

INITIAL SETUP

Materials:

None

Applicable Configurations:

All

Personnel Required:

68B10 Aircraft Powerplant Repairer

Tools:

Powerplant Mechanic's Tool Kit,
NSN 5180-00-323-4944

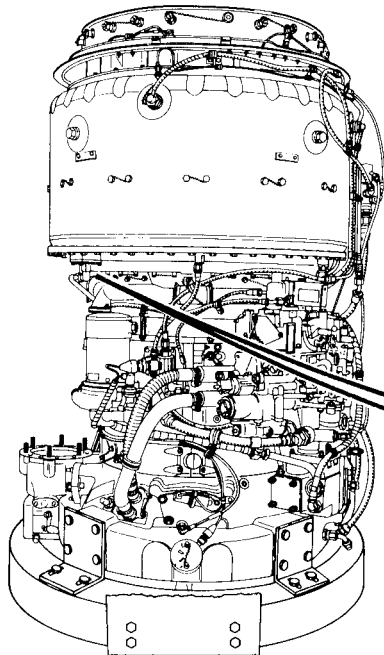

38 X 24

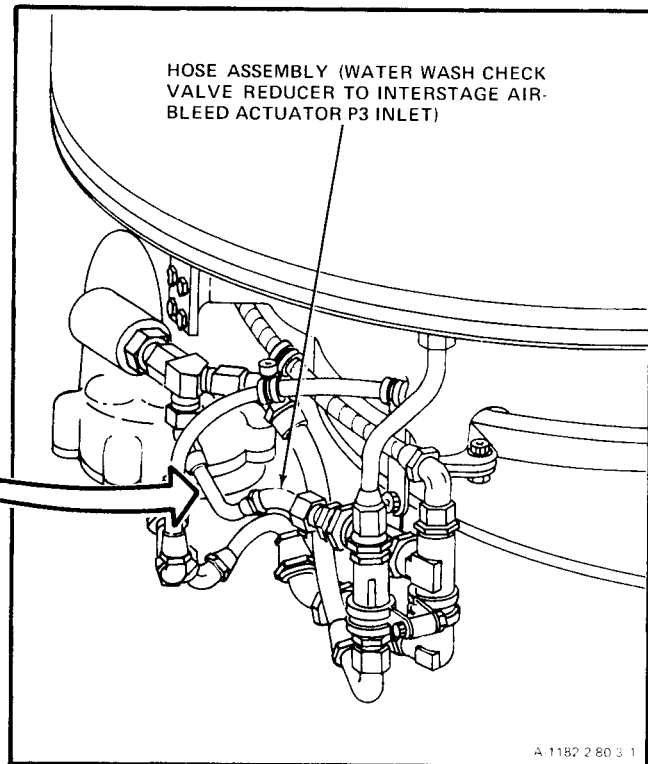

A 1182 2 80 3 1

GO TO NEXT PAGE

2-80.3 REMOVE HOSE ASSEMBLY (WATER WASH CHECK VALVE TO INTERSTAGE 2-80.3 AIR-BLEED ACTUATOR P3 INLET) (Continued)

1. Disconnect and remove hose assembly (1).

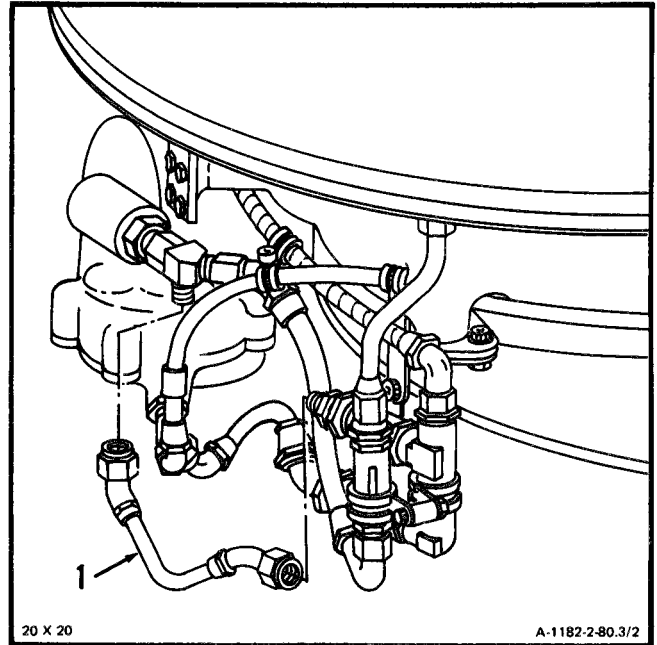

FOLLOW-ON MAINTENANCE:

None

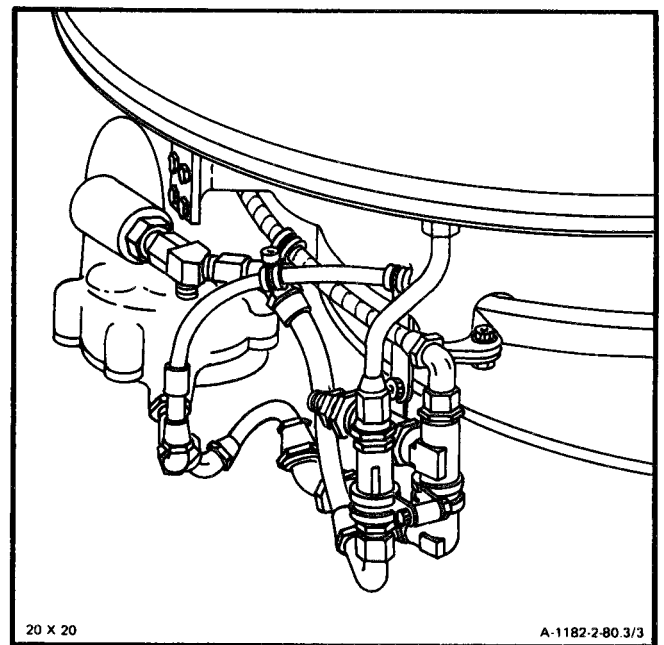

END OF TASK

2-80.4 INSTALL HOSE ASSEMBLY (WATER WASH CHECK VALVE TO INTERSTAGE 2-80.4 AIR-BLEED ACTUATOR P3 INLET)

INITIAL SETUP

Applicable Configurations:
All

Tools:
Powerplant Mechanic's Tool Kit,
NSN 518000323-4944
Technical Inspection Tool Kit,
NSN 5180-00323-5114

Materials:
None

Personnel Required:
68B1 O Aircraft Powerplant Repairer
68B13 Aircraft Powerplant Inspector

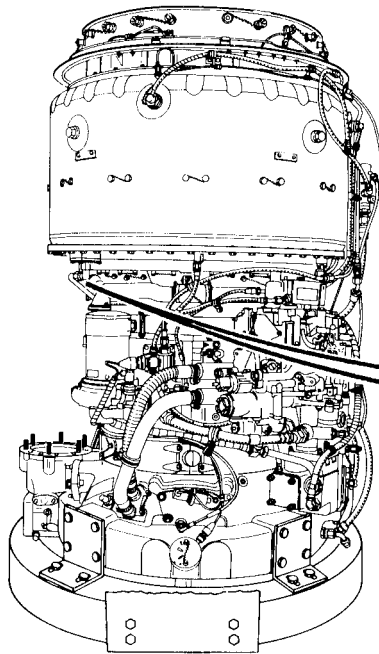

35 X 24

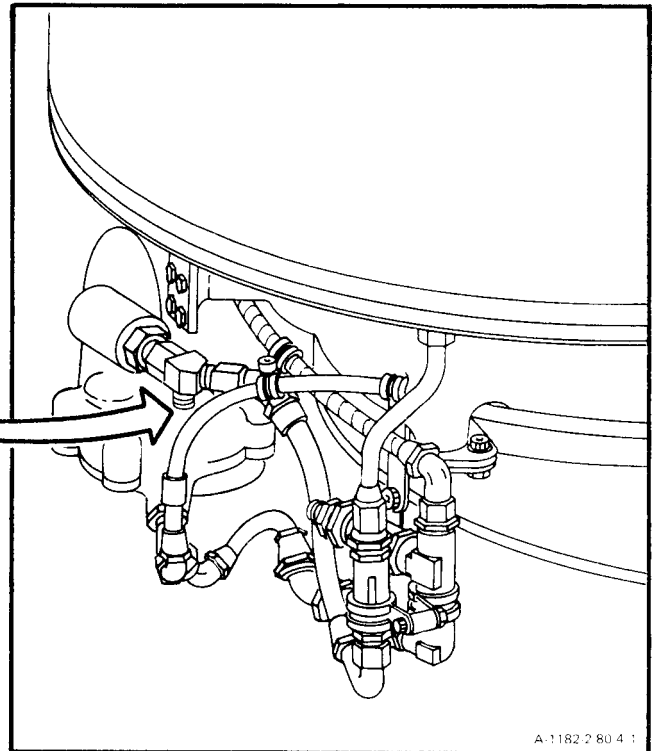

A-1182 2 80 4 1

GO TO NEXT PAGE

2-80.4 INSTALL HOSE ASSEMBLY (WATER WASH CHECK VALVE TO INTERSTAGE 2-80.4 AIR-BLEED ACTUATOR P3 INLET) (Continued)

1. Install hose assembly (1) on reducer (2) and air-bleed actuator P3 tee (3).

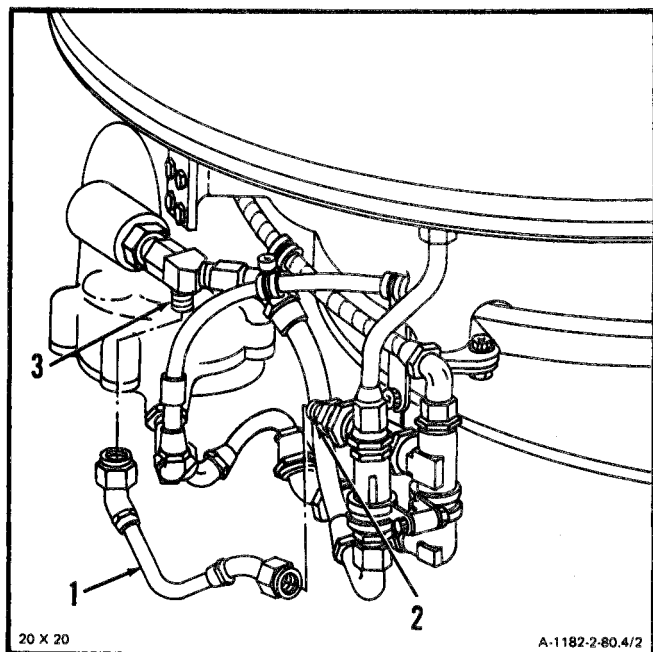

INSPECT

FOLLOW-ON MAINTENANCE:

None

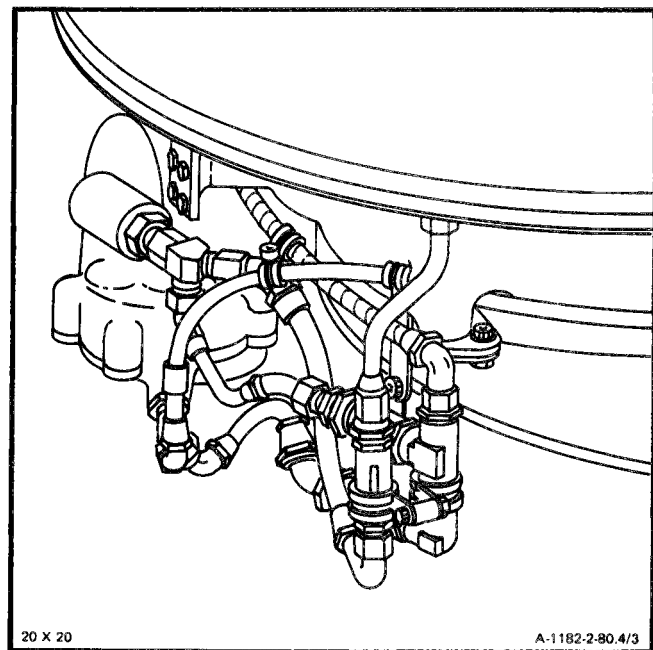

END OF TASK

2-80.5 REMOVE HOSE ASSEMBLY (WATER WASH TEE CHECK VALVE TO INTERSTAGE AIR-BLEED ACTUATOR P3 INLET)

2-80.5

INITIAL SETUP

Materials:

None

Applicable Configurations:

All

Personnel Required:

68B10 Aircraft Powerplant Repairer

Tools:

Powerplant Mechanic's Tool Kit,
NSN 5180-00-323-4944

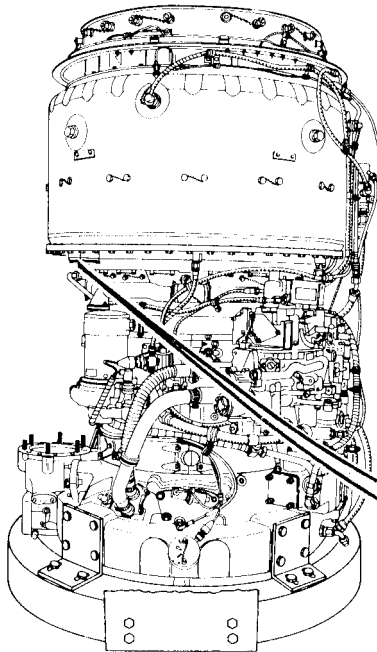

35 X 24

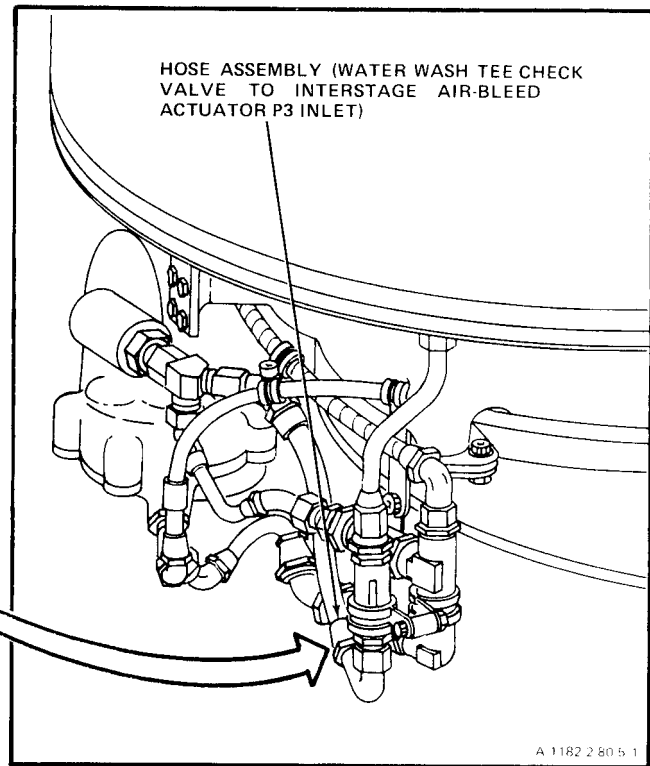

A 1182 2 80 5 1

GO TO NEXT PAGE

2-80.5 REMOVE HOSE ASSEMBLY (WATER WASH TEE CHECK VALVE TO INTERSTAGE AIR-BLEED ACTUATOR P3 INLET) (Continued)

2-80.5

1. Disconnect and remove hose assembly (1).

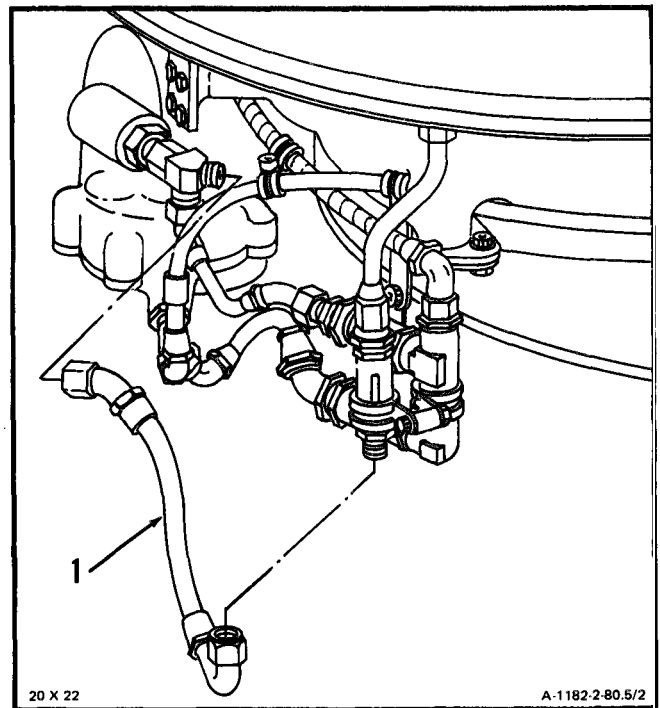

FOLLOW-ON MAINTENANCE:

None

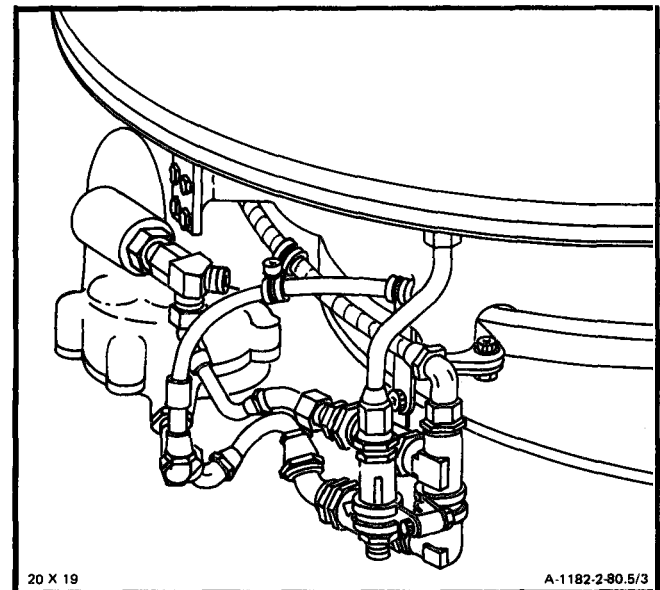

END OF TASK

2-80.6 INSTALL HOSE ASSEMBLY (WATER WASH TEE CHECK VALVE TO INTERSTAGE AIR-BLEED ACTUATOR P3 INLET)

2-80.6

INITIAL SETUP

Applicable Configurations:
All

Tools:
Powerplant Mechanic's Tool Kit,
NSN 518000-323-4944
Technical Inspection Tool Kit,
NSN 5180-003235114

Materials:
None

Personnel Required:
68610 Aircraft Powerplant Repairer

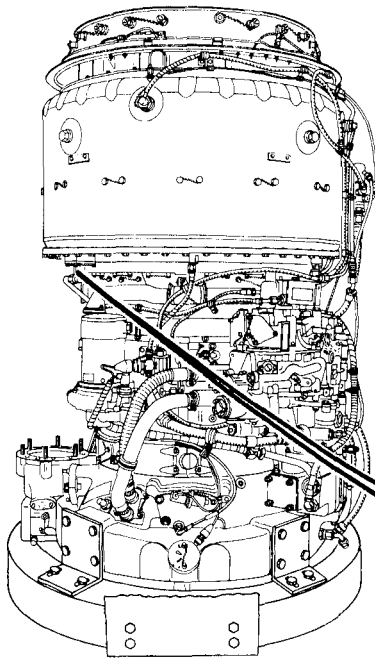

37 X 24

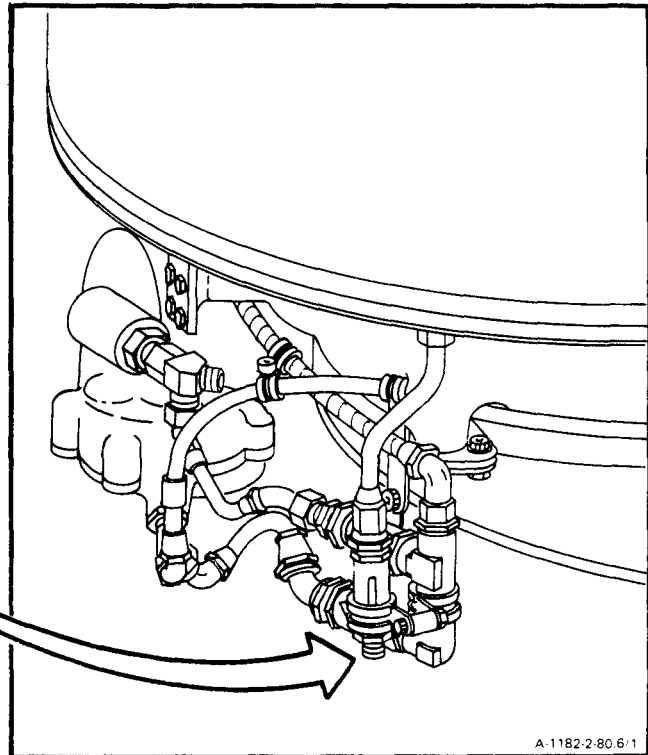

A:1182-2-80.6:1

GO TO NEXT PAGE

2-80.6 INSTALL HOSE ASSEMBLY (WATER WASH TEE VALVE TO INTERSTAGE AIR-BLEED ACTUATOR P3 INLET) (Continued)

2-80.6

1. Install hose assembly (1) on check valve (2) and air-bleed actuator P3 tee (3).

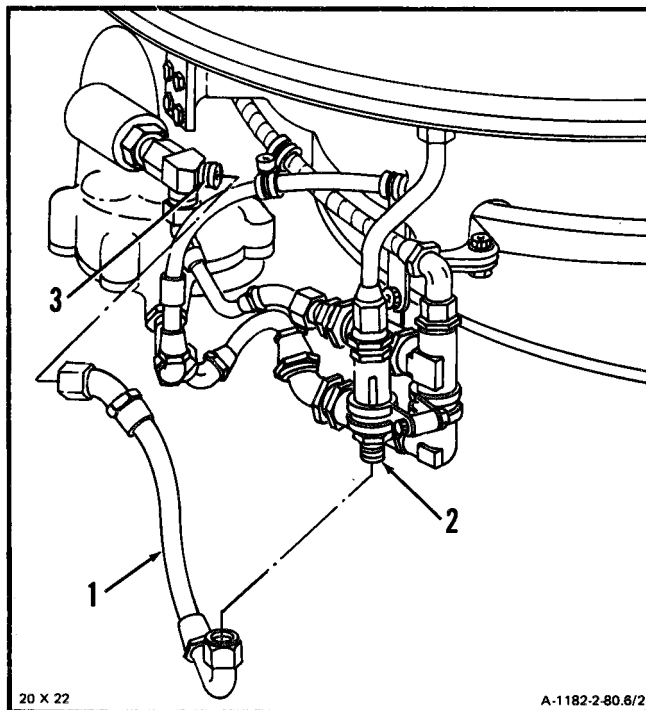

INSPECT

FOLLOW-ON MAINTENANCE:

None

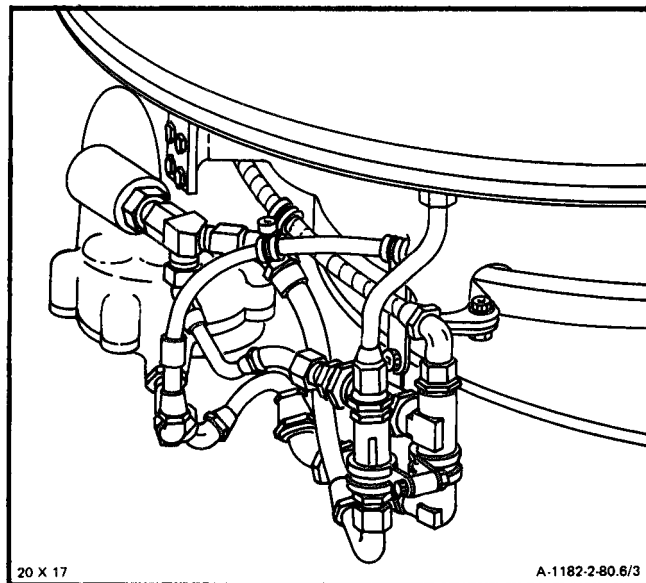

END OF TASK

2-80.7 REMOVE HOSE ASSEMBLY (WATER WASH CHECK VALVE ELBOW TO INTERSTAGE AIR-BLEED ACTUATOR FUEL CONTROL INLET)

2-80.7

INITIAL SETUP

Applicable Configurations:

All

Tools:

Powerplant Mechanic's Tool Kit,
NSN 5180-00-323-4944

Materials:

None

Personnel Required:

68B10 Aircraft Powerplant Repairer

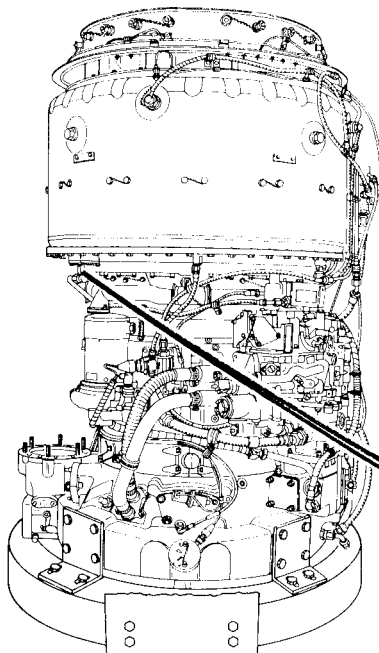

34 X 24

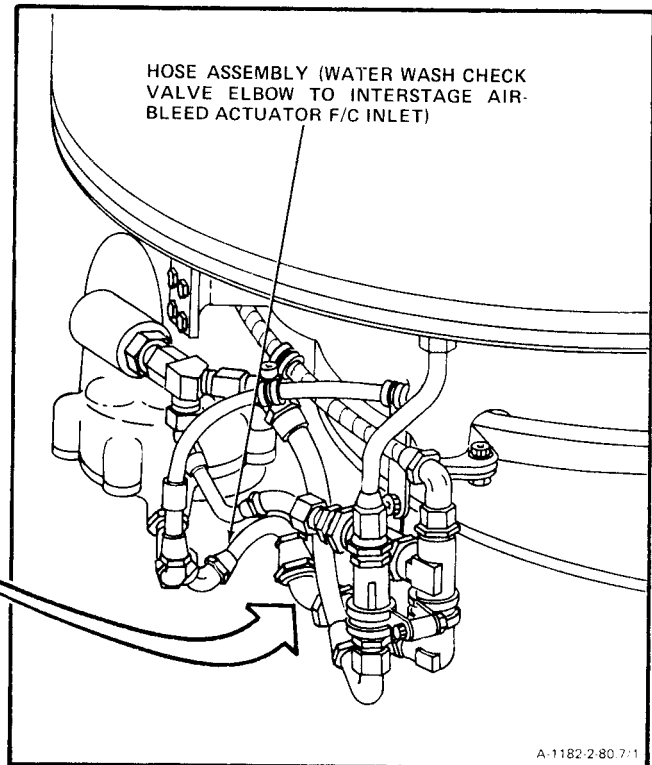

A-1182-2-80.7:1

GO TO NEXT PAGE

2-80.7 REMOVE HOSE ASSEMBLY (WATER WASH CHECK VALVE ELBOW TO INTERSTAGE AIR-BLEED ACTUATOR FUEL CONTROL INLET) (Continued)

2-80.7

1. Disconnect and remove hose assembly (1).

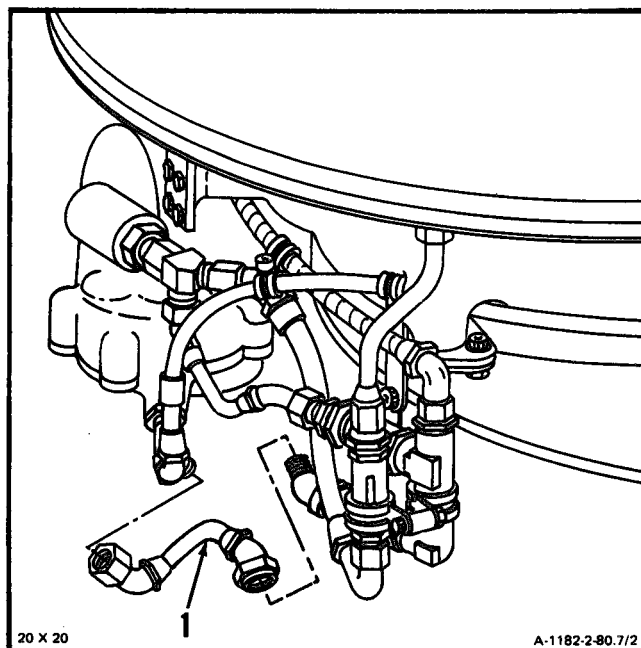
**FOLLOW-ON MAINTENANCE:**

None

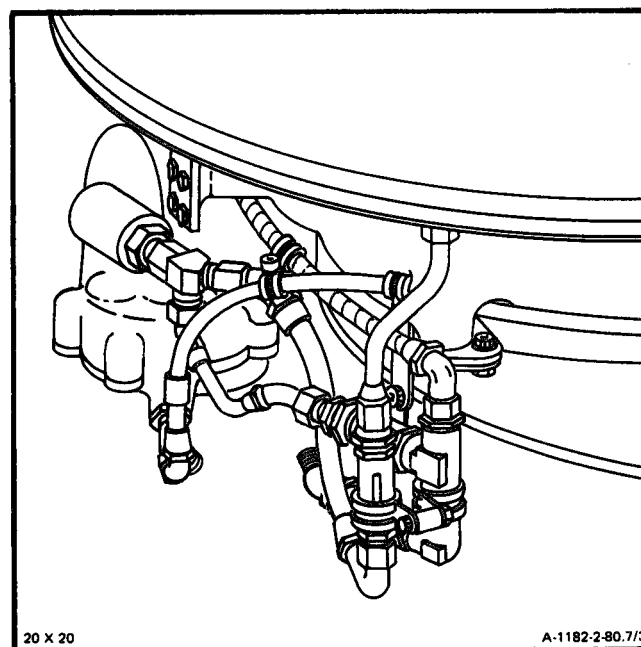
**END OF TASK**

2-80.8 INSTALL HOSE ASSEMBLY (WATER WASH CHECK VALVE ELBOW TO INTERSTAGE AIR-BLEED ACTUATOR FUEL CONTROL INLET)

2-80.8

INITIAL SETUP

Applicable Configurations:

All

Tools:

Powerplant Mechanic's Tool Kit,
NSN 5180-00-323-4944
Technical Inspection Tool Kit,
NSN 5180-00-323-114

Materials:

None

Personnel Required:

68B10 Aircraft Powerplant Repairer
68B13 Aircraft Powerplant Inspector

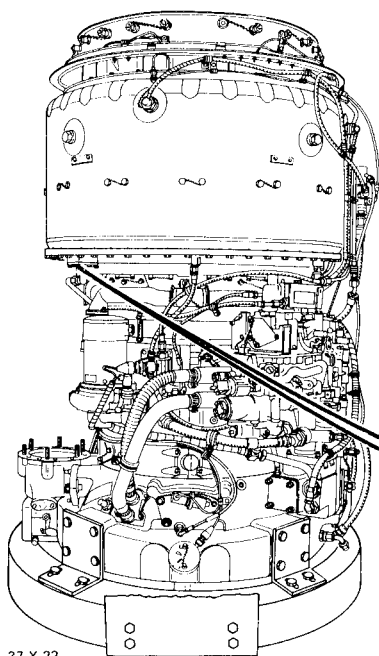

37 X 22

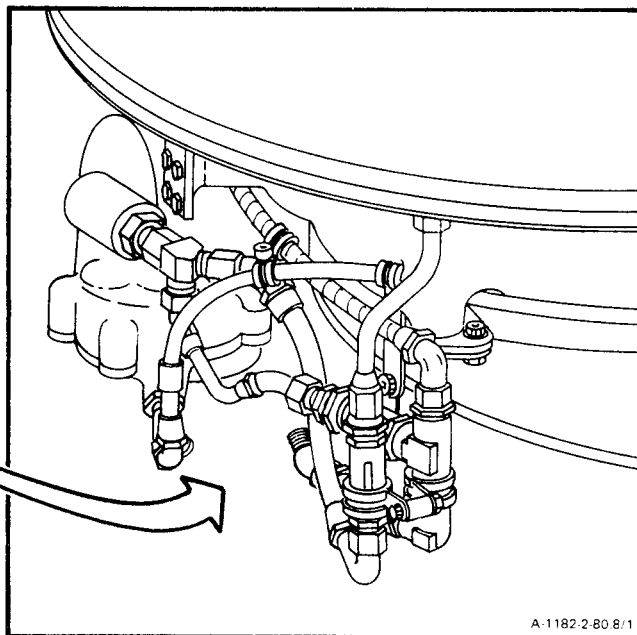

A-1182-2-80.8/1

GO TO NEXT PAGE

2-80.8 INSTALL HOSE ASSEMBLY (WATER WASH CHECK VALVE ELBOW TO INTERSTAGE AIR-BLEED ACTUATOR FUEL CONTROL INLET) (Continued)

2-80.8

1. Install hose assembly (1) on check valve elbow (2) and air-bleed actuator Pm inlet tee (3).

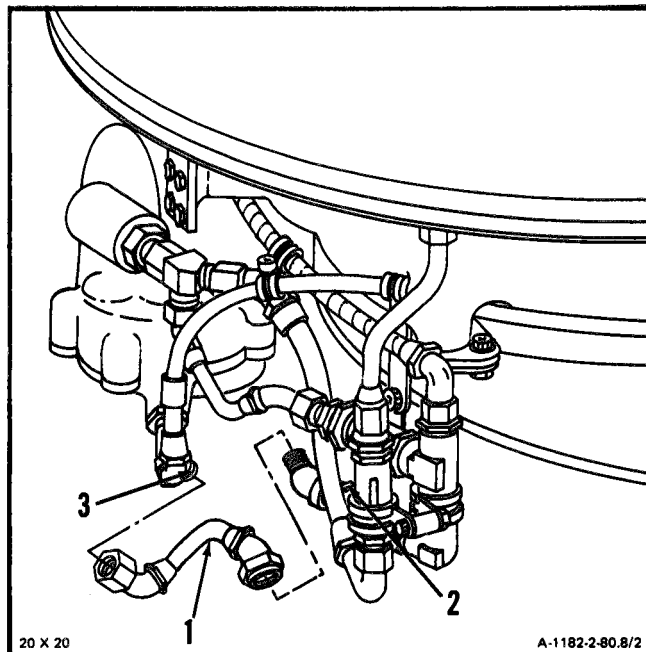

INSPECT

FOLLOW-ON MAINTENANCE:

None

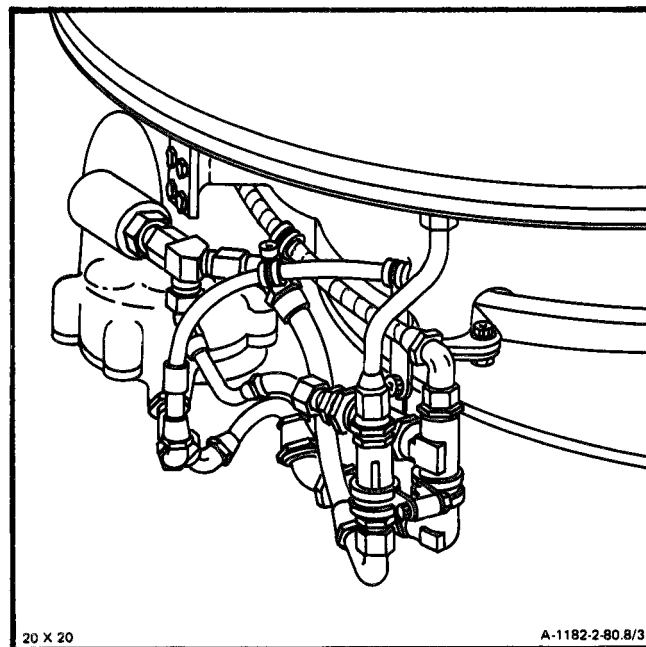

END OF TASK

2-80.9 REMOVE HOSE ASSEMBLY (WATER WASH KIT INSTALLATION TO AIRFRAME QUICK DISCONNECT SHELF)

2-80.9

INITIAL SETUP

Applicable Configurations:

All

Tools:

Powerplant Mechanic's Tool Kit,
NSN 5180-00-323-4944

Materials:

None

Personnel Required:

68B10 Aircraft Powerplant Repairer

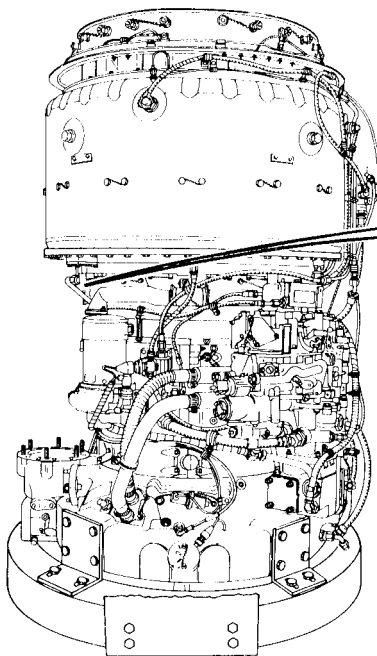

42 X 24

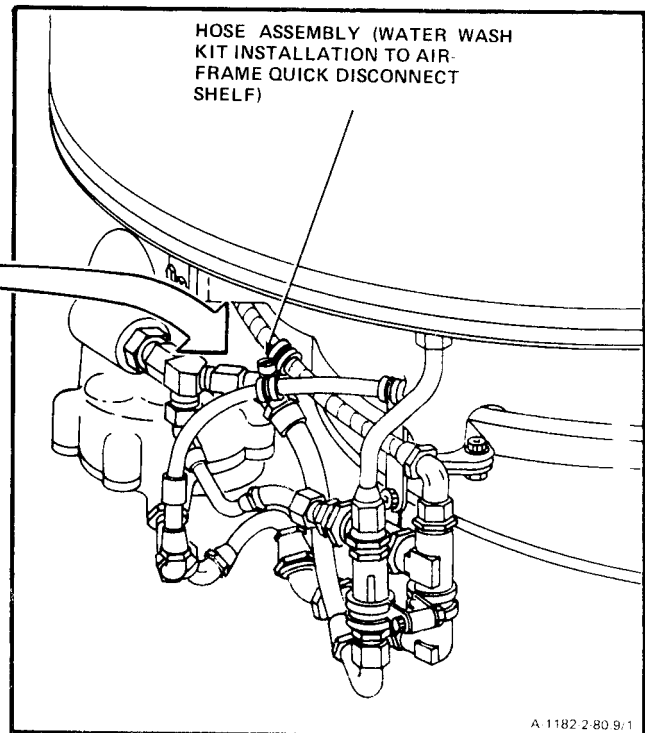

A 1182 2-80 9:1

GO TO NEXT PAGE

2-80.9 REMOVE HOSE ASSEMBLY (WATER WASH KIT INSTALLATION TO AIRFRAME QUICK DISCONNECT SHELF) (Continued)

1. **Remove** nut (1), screw (2) and **clamp** (3).

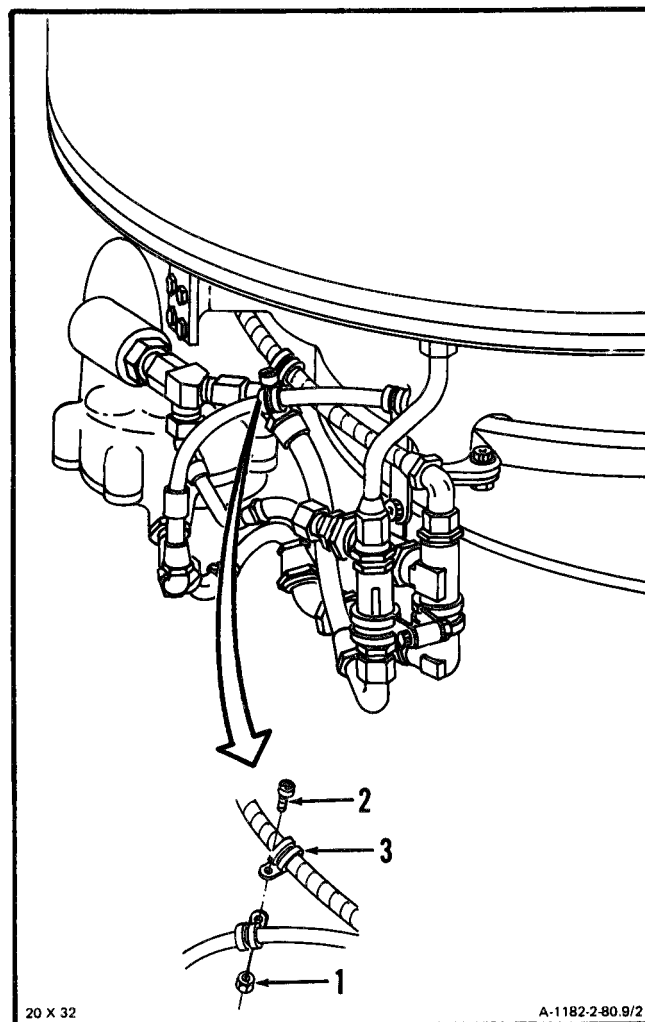

20 X 32

A-1182-2-80.9/2

GO TO NEXT PAGE

2-80.9 REMOVE HOSE ASSEMBLY (WATER WASH KIT INSTALLATION TO AIRFRAME QUICK DISCONNECT SHELF) (Continued)

2-80.9

2. Remove nut (4), screws (5) and clamp (6).

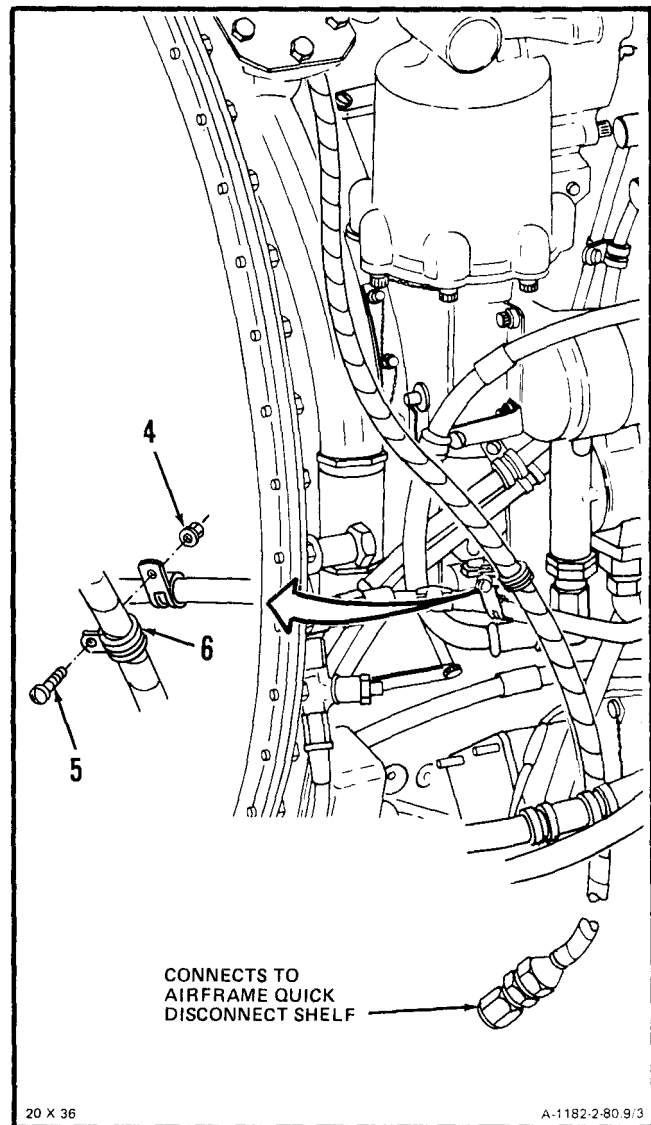

GO TO NEXT PAGE

2-80.9 REMOVE HOSE ASSEMBLY (WATER WASH KIT INSTALLATION TO AIRFRAME QUICK DISCONNECT SHELF) (Continued)

2-80.9

3. Disconnect and remove hose assembly (7).

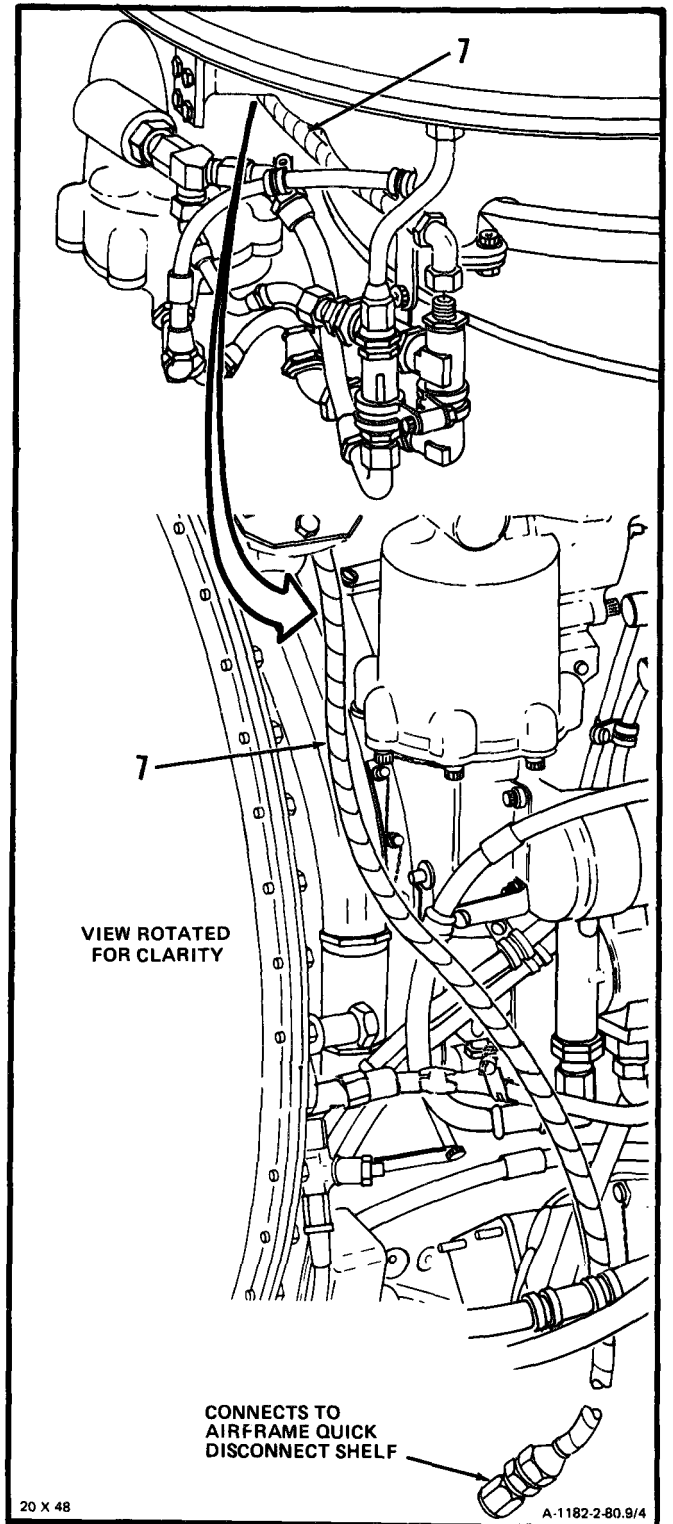

INSPECT

GO TO NEXT PAGE

2-80.9 REMOVE HOSE ASSEMBLY (WATER WASH KIT INSTALLATION TO AIRFRAME QUICK DISCONNECT SHELF) (Continued)

2-80.9

FOLLOW-ON MAINTENANCE:

None

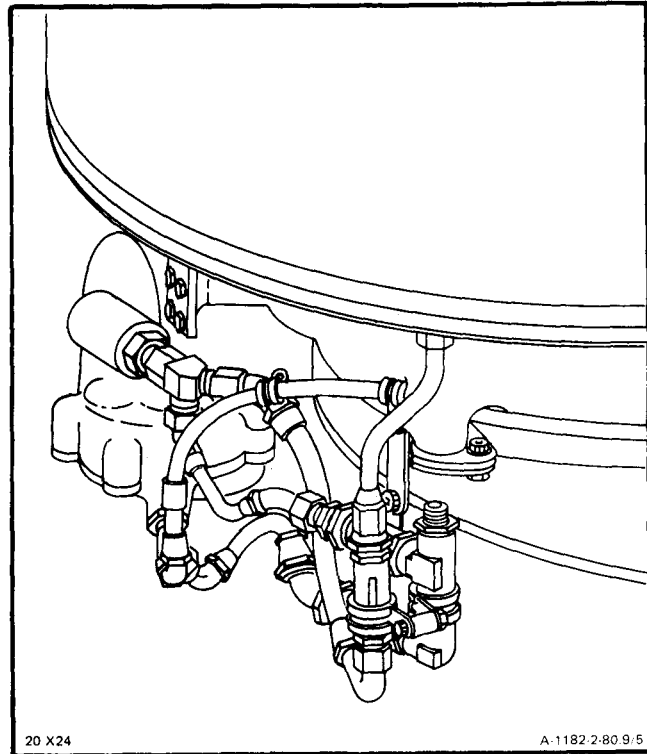

END OF TASK

2-80.10 INSTALL HOSE ASSEMBLY (WATER WASH KIT INSTALLATION TO AIRFRAME QUICK DISCONNECT SHELF)

2-80.10

INITIAL SETUP

Applicable Configurations

All

Tools:

Powerplant Mechanic's Tool Kit,
NSN 5180-00-323-4944
Technical Inspection Tool Kit,
NSN 5180-00-323-5114

Materials:

None

Personnel Required:

68B10 Aircraft Powerplant Repairer
68B30 Aircraft Powerplant Inspector

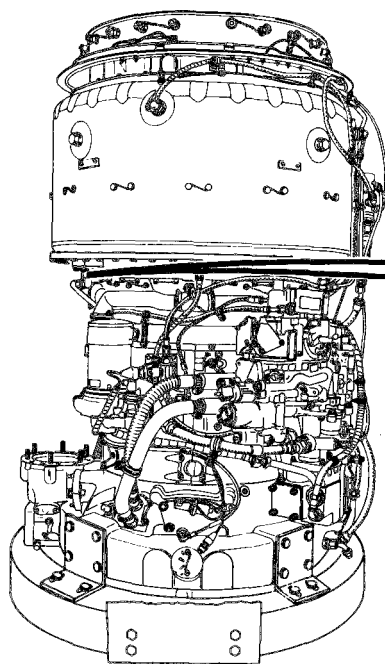

36 X 24

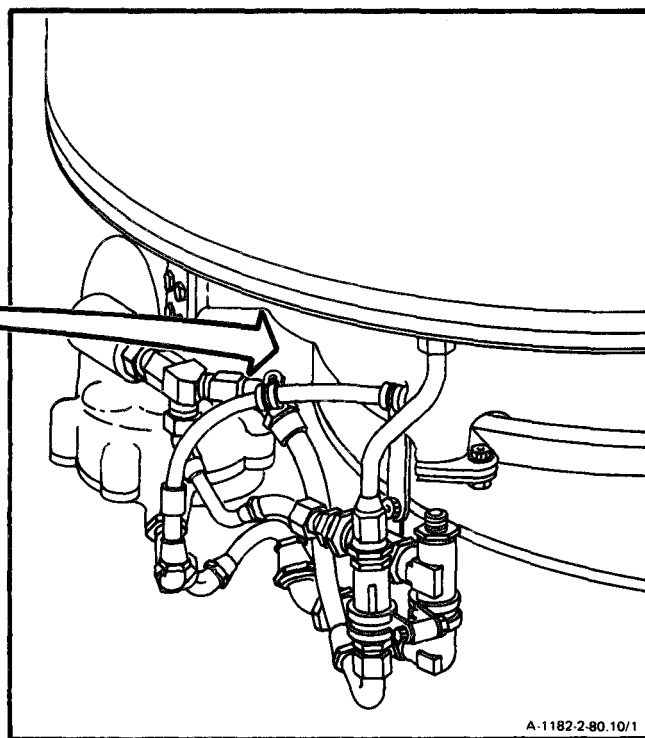

A-1182-2-80.10/1

GO TO NEXT PAGE

2-80.10 INSTALL HOSE ASSEMBLY (WATER WASH KIT INSTALLATION TO AIRFRAME QUICK DISCONNECT SHELF) (Continued)

2-80.10

1. **Install hose assembly (1) on check valve (2),** and position hose assembly across top of compressor housing parallel to the bleed band and down right side of engine.

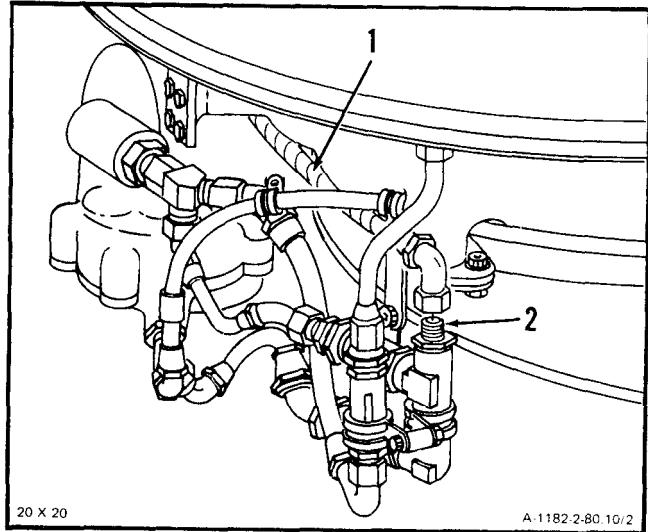

2. **Install clamp (3) on hose assembly (1) and** install screw (4) and nuts (5).

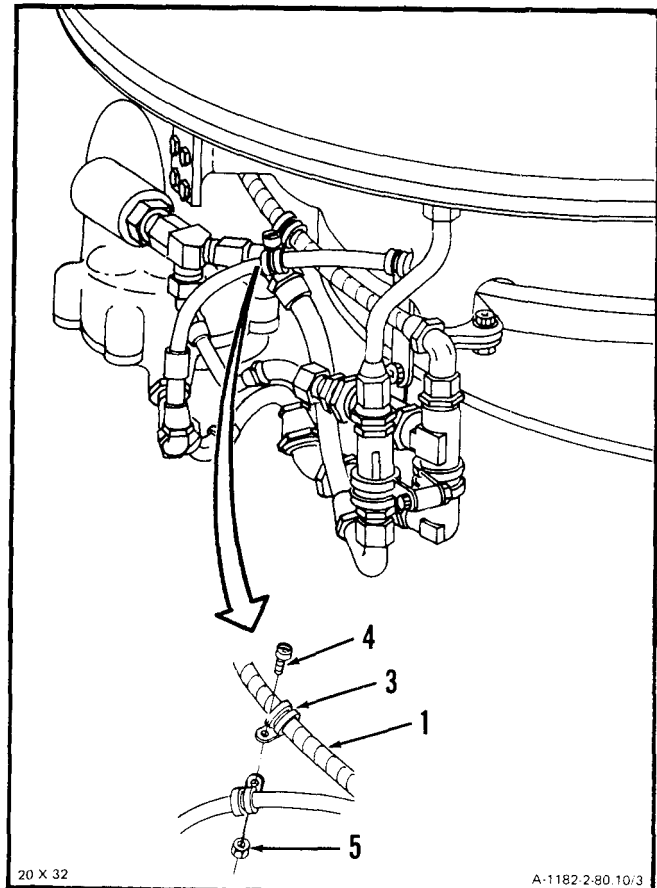

GO TO NEXT PAGE

2-80.10 INSTALL HOSE ASSEMBLY (WATER WASH KIT INSTALLATION TO AIRFRAME QUICK DISCONNECT SHELF) (Continued)

2-80.10

3. Install clamp (6) on hose assembly (1) and install screw (7) and nut (8).

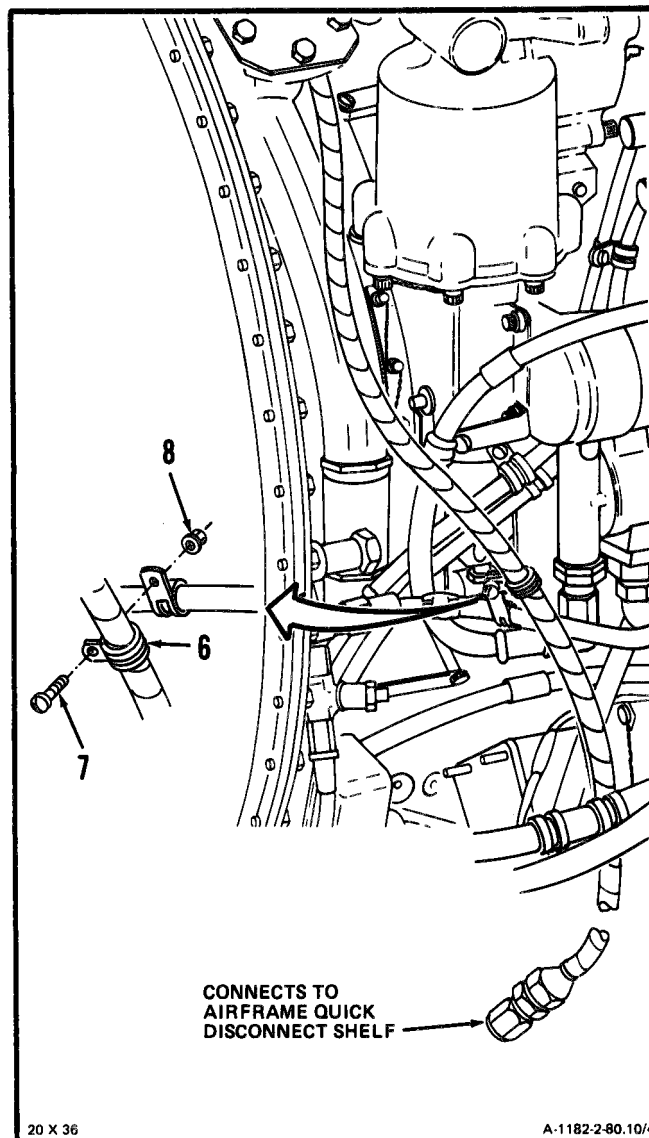
**INSPECT****GO TO NEXT PAGE**

2-80.10 INSTALL HOSE ASSEMBLY (WATER WASH KIT INSTALLATION TO AIRFRAME QUICK DISCONNECT SHELF) (Continued)

2-80.10

FOLLOW-ON MAINTENANCE:

None

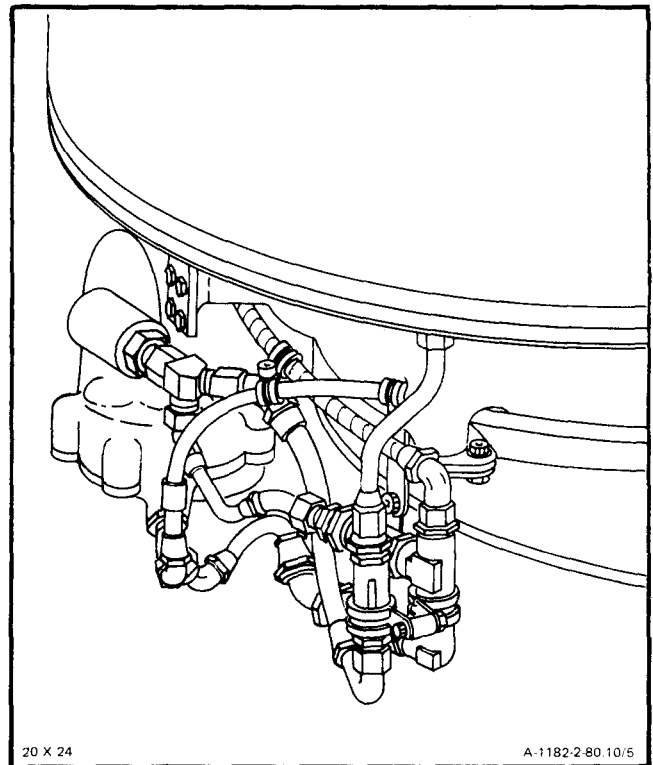

END OF TASK

2-80.11 REMOVE CHECK VALVE (AIR DIFFUSER TO INTERSTAGE AIR-BLEED ACTUATOR)

2-80.11

INITIAL SETUP

Materials:
Packings

Applicable Configurations:
All

Personnel Required:
68B10 Aircraft Powerplant Repairer

Tools:
Powerplant Mechanic's Tool Kit,

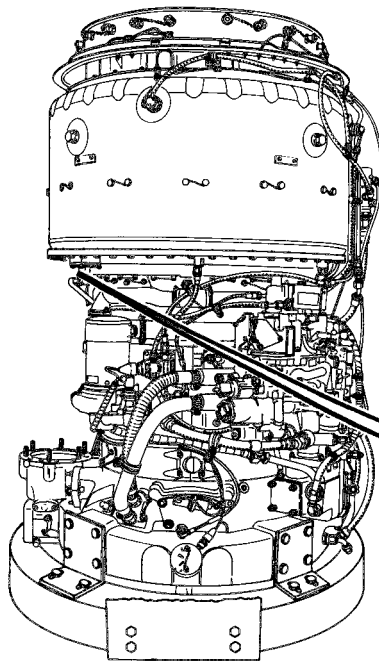

36 X 24

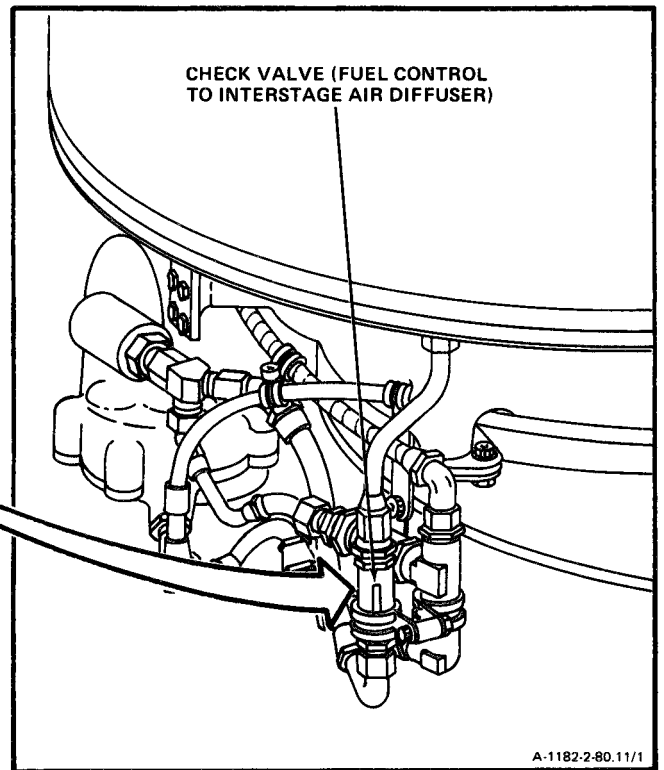

A-1182-2-80.11/1

GO TO NEXT PAGE

2-80.11 REMOVE CHECK VALVE (AIR DIFFUSER TO INTERSTAGE AIR-BLEED ACTUATOR) (Continued)

2-80.11

1. Remove nut (1), screw (2) and spacer (3).

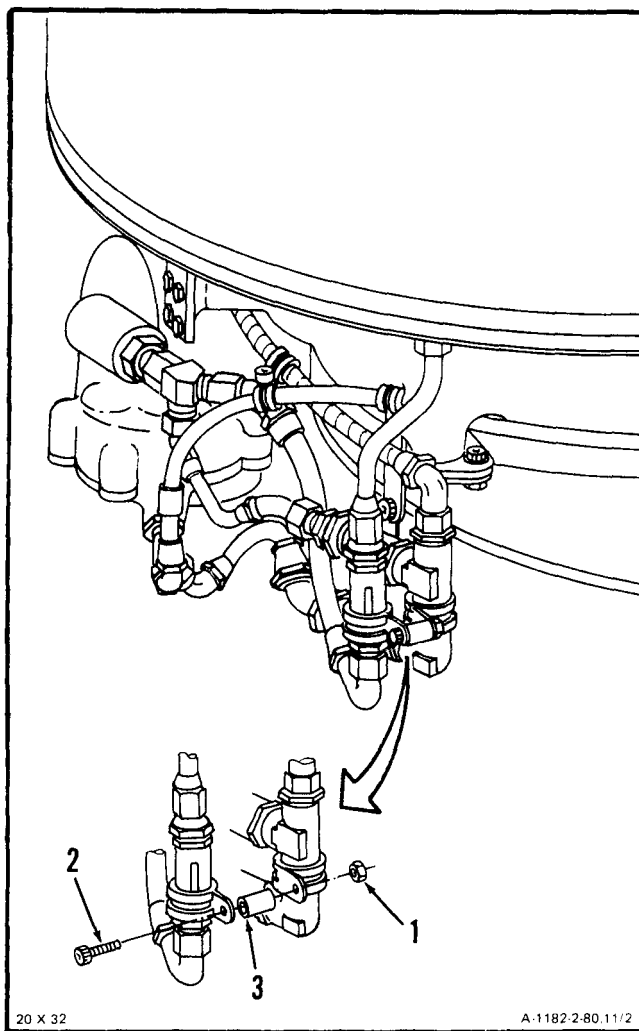

20 X 32

A-1182-2-80.11/2

GO TO NEXT PAGE

2-80.11 REMOVE CHECK VALVE (AIR DIFFUSER TO INTERSTAGE AIR-BLEED ACTUATOR) (Continued)

2-80.11

2. Disconnect hose assembly (4) from check valve (5).

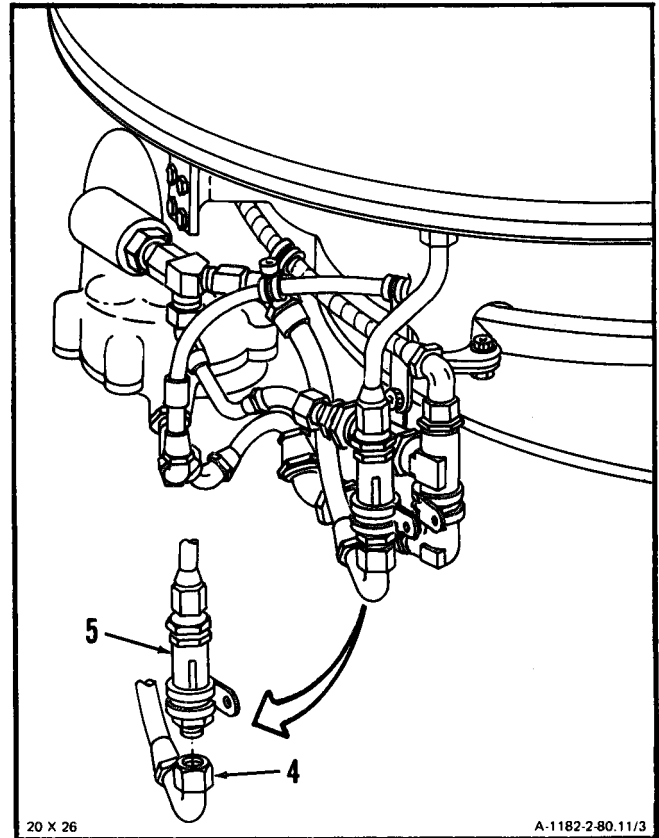

3. Remove check valve (5) from tube assembly (6).

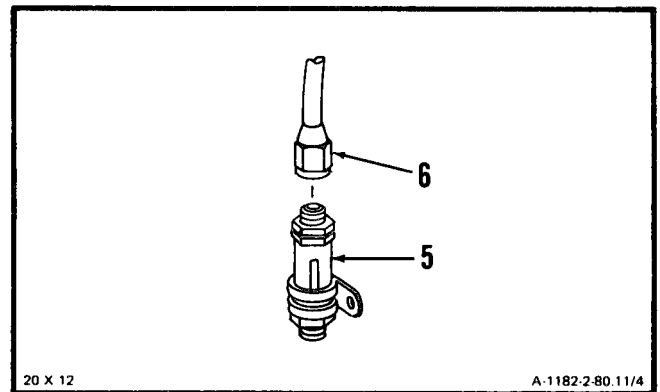

4. Remove clamp (7) from check valve (5).

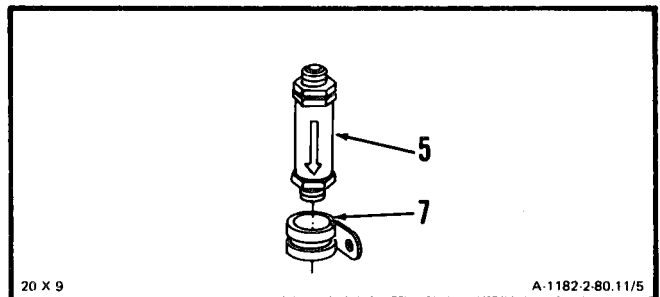

GO TO NEXT PAGE

2-80.11 REMOVE CHECK VALVE (AIR DIFFUSER TO INTERSTAGE AIR-BLEED ACTUATOR) (Continued)

2-80.11

FOLLOW-ON MAINTENANCE:

None

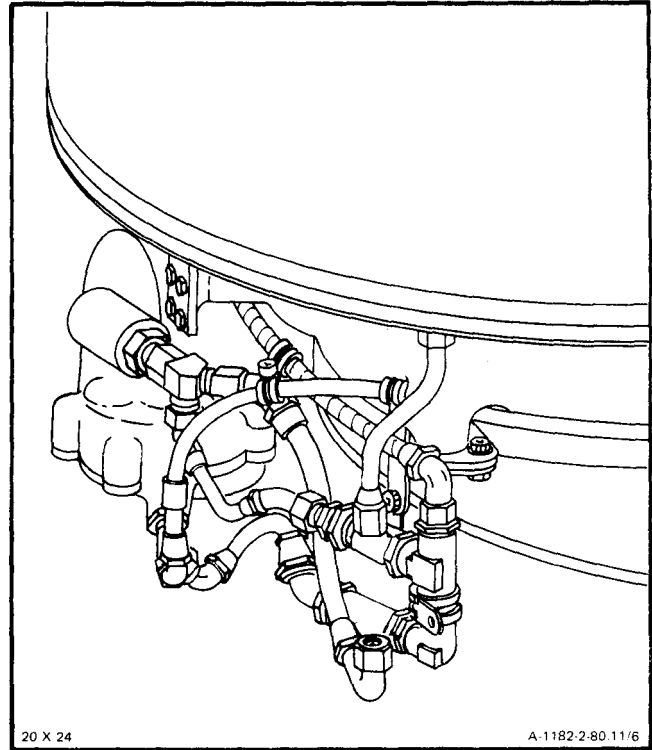

END OF TASK

2-80.12 CLEAN CHECK VALVE (AIR DIFFUSER TO INTERSTAGE AIRBLEED ACTUATOR)

2-80.12

INITIAL SETUP

Applicable Configurations:

All

Tools:

Powerplant Mechanic's Tool Kit,
NSN 5180-00-323-4944

Goggles

Compressed Air Source

Materials:

Dry Cleaning Solvent (E17)
Gloves (E20)
Lint-Free Cloth (E26)

Equipment Condition:

Off Engine Task
Check Valve (Air diffuser to
interstage air-bleed actuator
removal (Task 2-80.11)

General Safety Instructions:**WARNING**

Dry cleaning solvent (E17) is flammable and toxic. It can irritate skin and cause burns. Use only in well-ventilated area, away from heat and open flame. In case of contact immediately flush skin or eyes with water for at least 15 minutes. Get medical attention for eyes.

1. Wear gloves (E20). **Clean check valve (1)** and nipple (2) using dry cleaning solvent (E17) and brush.

WARNING

When using compressed air for cleaning, use approved protective equipment for eyes and face. Do not use more than 30 psig air pressure. Do not direct air toward yourself or another person. Failure to comply could result in injury to eyes or skin. In case of injury, get medical attention.

2. Wear goggles. **Blow dry check valve (1)** and nipple (2) using clean, dry compressed air.

FOLLOW-ON MAINTENANCE:

None

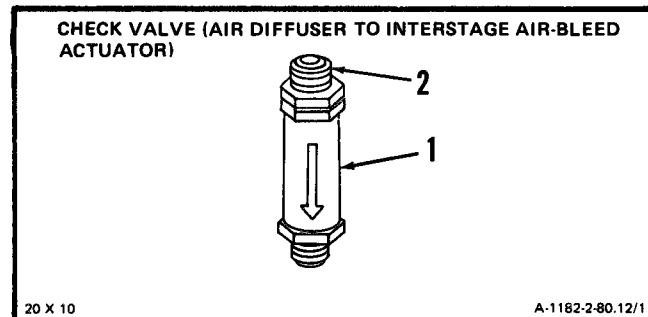

END OF TASK

**22-80.13 INSTALL CHECK VALVE (AIR DIFFUSER TO INTERSTAGE
AIR-BLEED ACTUATOR)**

2-80.13

INITIAL SETUP

Applicable Configurations:

All

Tools:

Powerplant Mechanic's Tool Kit,
NSN 5180-00323-4944
Technical Inspection Tool Kit,
NSN 5180-00-323-5114

Materials:

None

Personnel Required:

68B10 Aircraft Powerplant Repairer

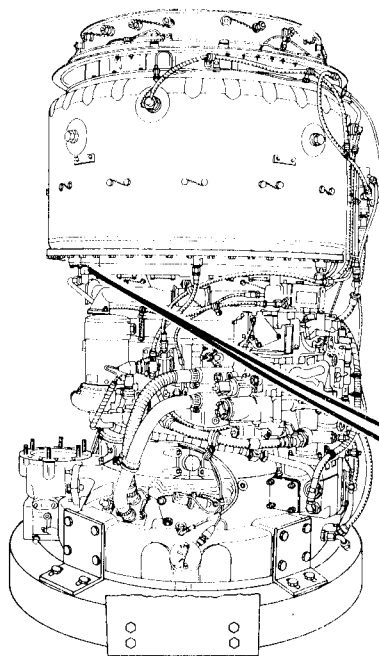

36 X 24

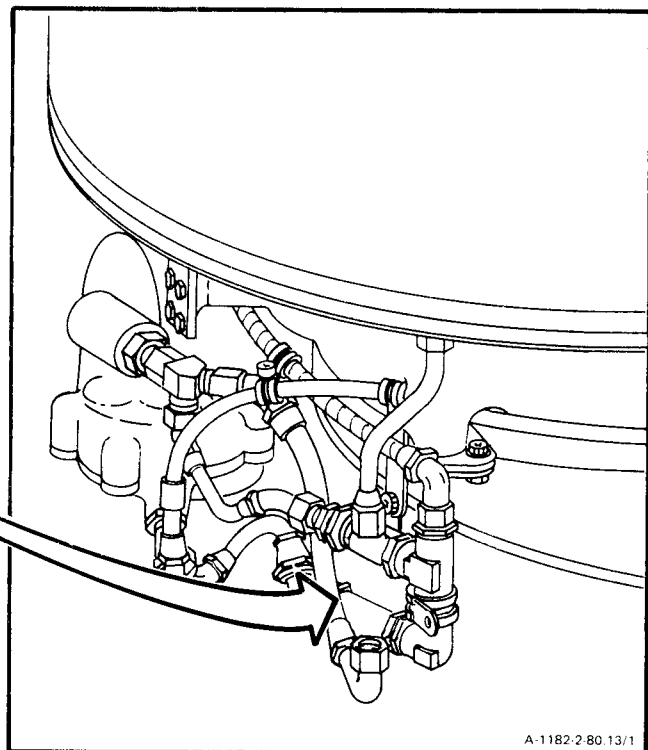

A-1182-2-80.13/1

GO TO NEXT PAGE

2-80.13 INSTALL CHECK VALVE (AIR DIFFUSER TO INTERSTAGE
AIR-BLEED ACTUATOR) (Continued)

2-80.13

NOTE

If check valve is a replacement do steps 1. and 2. If same check valve that was removed is to be installed, omit steps 1. and 2. and proceed to step 3.

1. **Remove nipple (1) and packing (2) from removed check valve (3).**
2. **Install packing (2) and nipple (1) in serviceable check valve (3).**

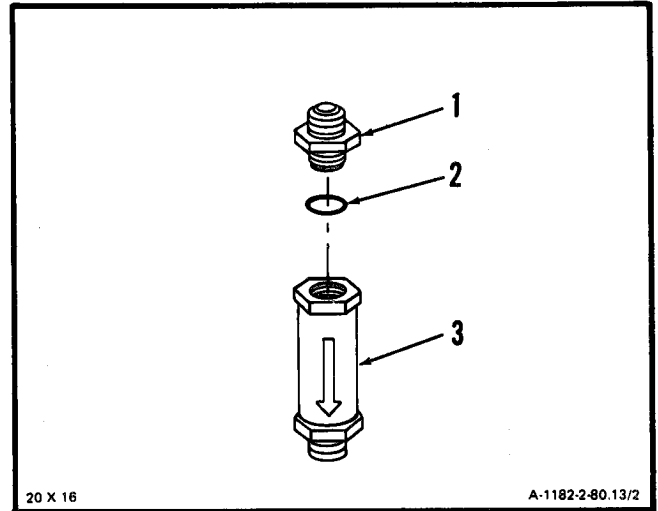

20 X 16

A-1182-2-80.13/2

GO TO NEXT PAGE

2-80.13 INSTALL CHECK VALVE (AIR DIFFUSER TO INTERSTAGE
AIR-BLEED ACTUATOR) (Continued)

2-80.13

3. Install clamp (4) on check valve (3).

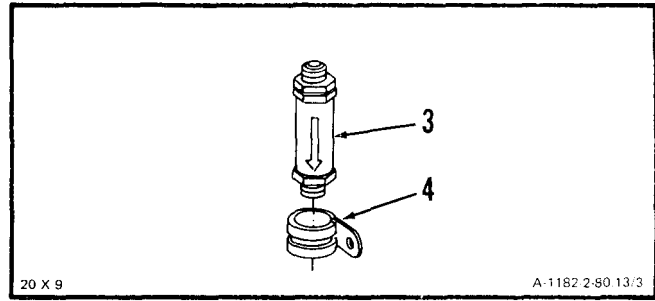

GO TO NEXT PAGE

**2-80.13 INSTALL CHECK VALVE (AIR DIFFUSER TO INTERSTAGE
AIR-BLEED ACTUATOR) (Continued)****2-80.13****CAUTION**

In following step, when installing check valve, ensure arrow on check valve indicates proper direction of air flow is positioned as shown in figure.

4. Install check valve (3) on tube assembly (5).

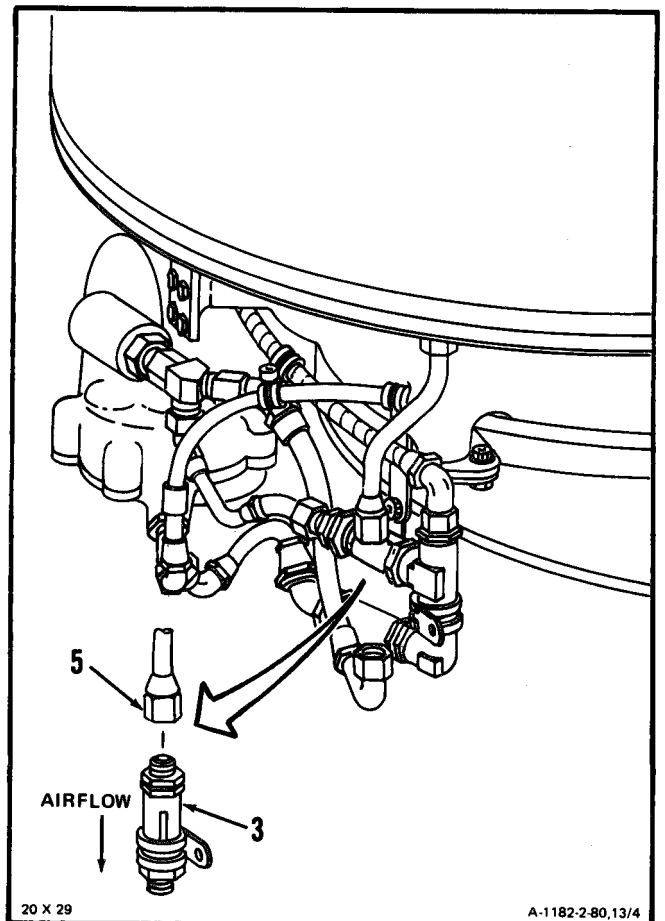
**GO TO NEXT PAGE**

**2-80.13 INSTALL CHECK VALVE (AIR DIFFUSER To INTERSTAGE
AIR-BLEED ACTUATOR) (Continued)**

2-80.13

5. Install hose assembly (6) on check valve (3).

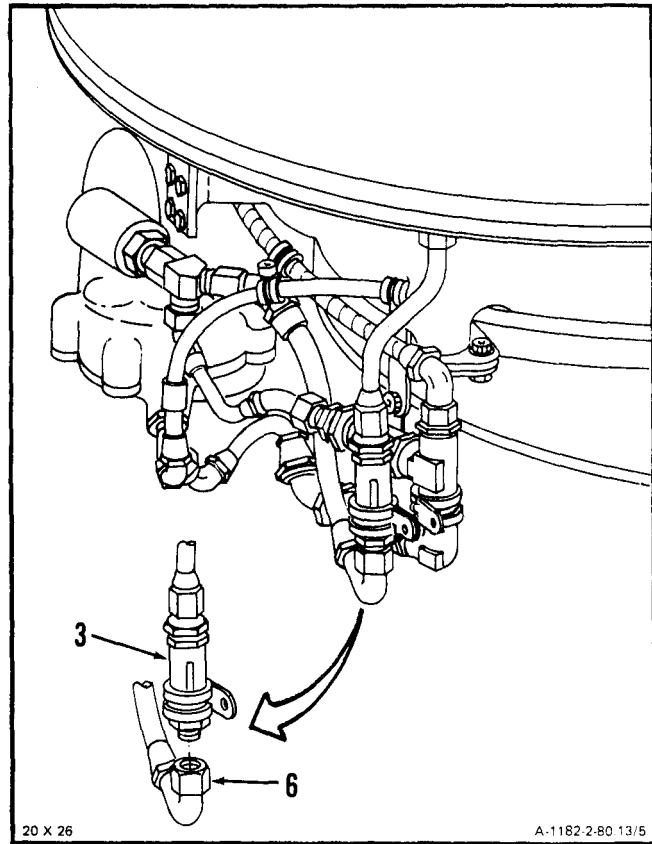

GO TO NEXT PAGE

**2-80.13 INSTALL CHECK VALVE (AIR DIFFUSER TO INTERSTAGE
AIR-BLEED ACTUATOR) (Continued)**

2-80.1

6. Install spacer (7), screw (8) and nut (9).

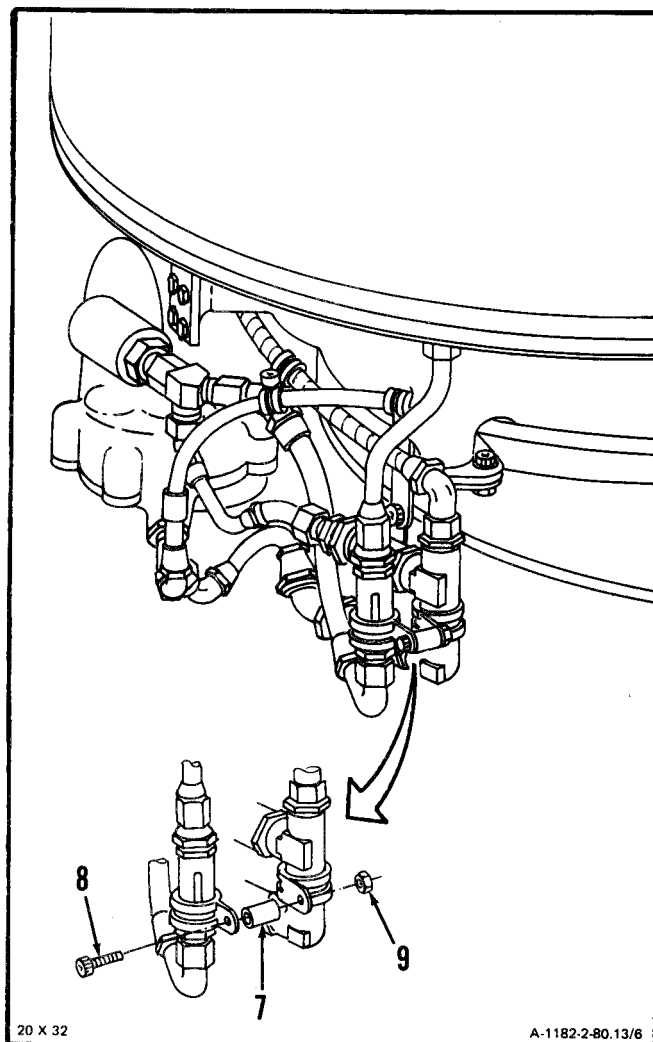

INSPECT

GO TO NEXT PAGE

**2-80.13 INSTALL CHECK VALVE (AIR DIFFUSER TO INTERSTAGE
AIR-BLEED ACTUATOR) (Continued)**

2-80.13

FOLLOW-ON MAINTENANCE:

None

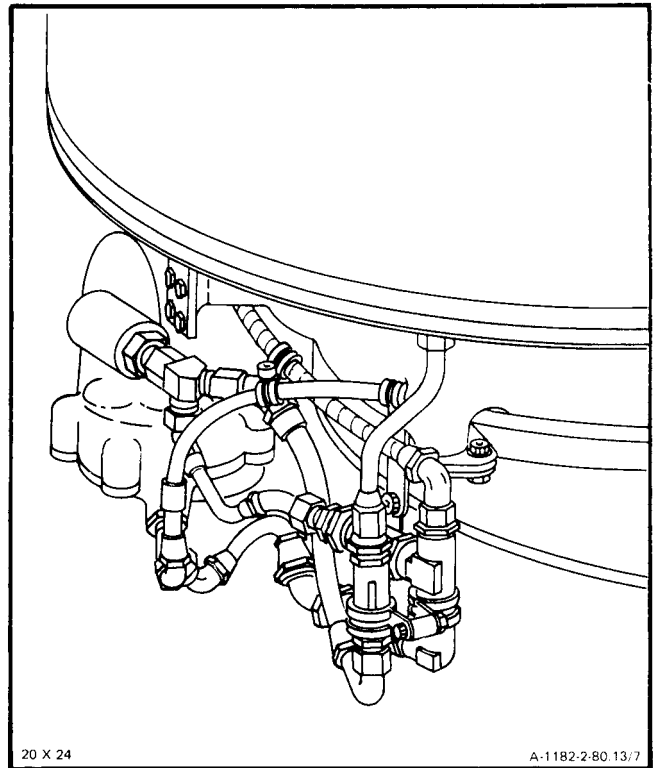

END OF TASK

**2-80.14 REMOVE CHECK VALVE (WATER WASH TEE TO INTERSTAGE
AR-BLEED ACTUATOR P3 INLET)**

2-80.14

INITIAL SETUP

Applicable Configurations:

All

Tools:Powerplant Mechanic's Tool Kit,
NSN 5180-00-323-4944**Materials:**

None

Personnel Required:

68B10 Aircraft Powerplant Repairer

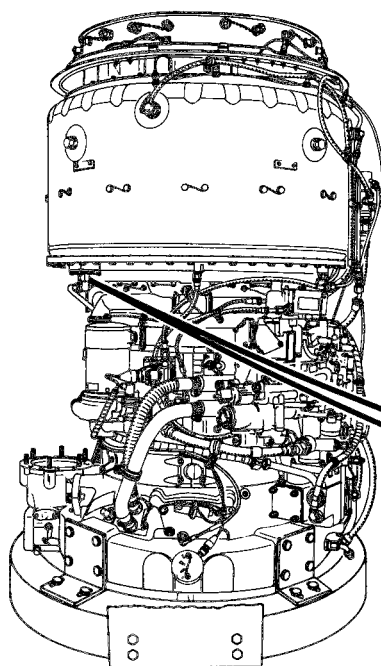

36 X 24

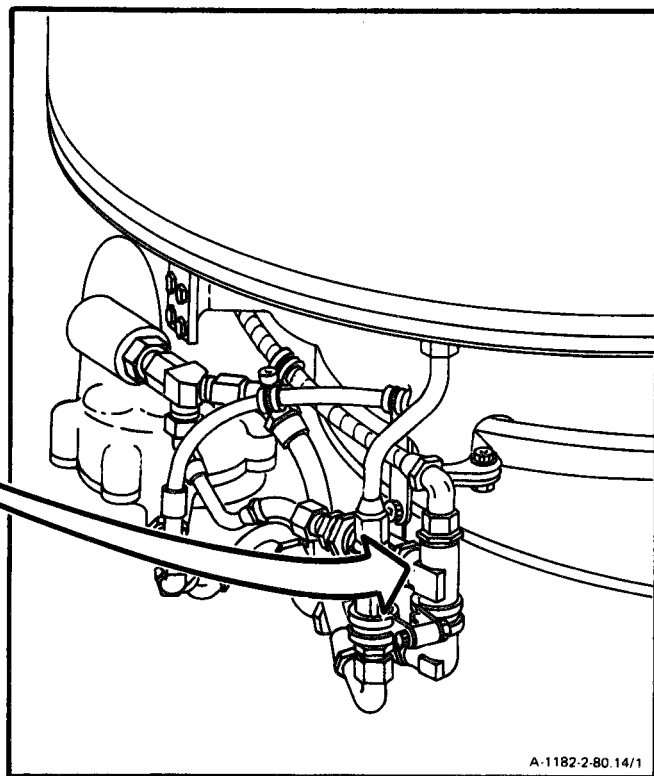

A-1182-2-80.14/1

GO TO NEXT PAGE

2-80.14 REMOVE CHECK VALVE (WATER WASH TEE TO INTERSTAGE AIR-BLEED ACTUATOR P3 INLET) (Continued)

2-80.14

1. **Remove** lockwire, and **bolt (1)** from clamp (2) and bleed band retainer (3).

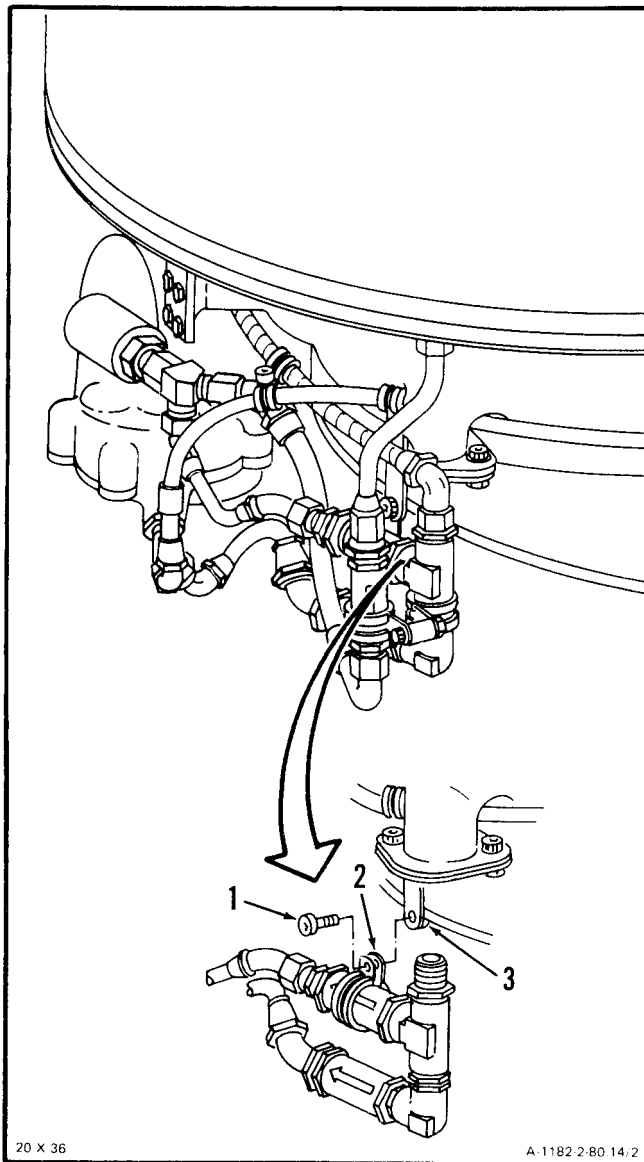

20 X 36

A 1182 2-80.14.2

GO TO NEXT PAGE

**2-80.14 REMOVE CHECK VALVE (WATER WASH TEE TO INTERSTAGE
AIR-BLEED ACTUATOR P3 INLET) (Continued)**

2-80.14

2. Disconnect hose assembly (4) from check valve (5).

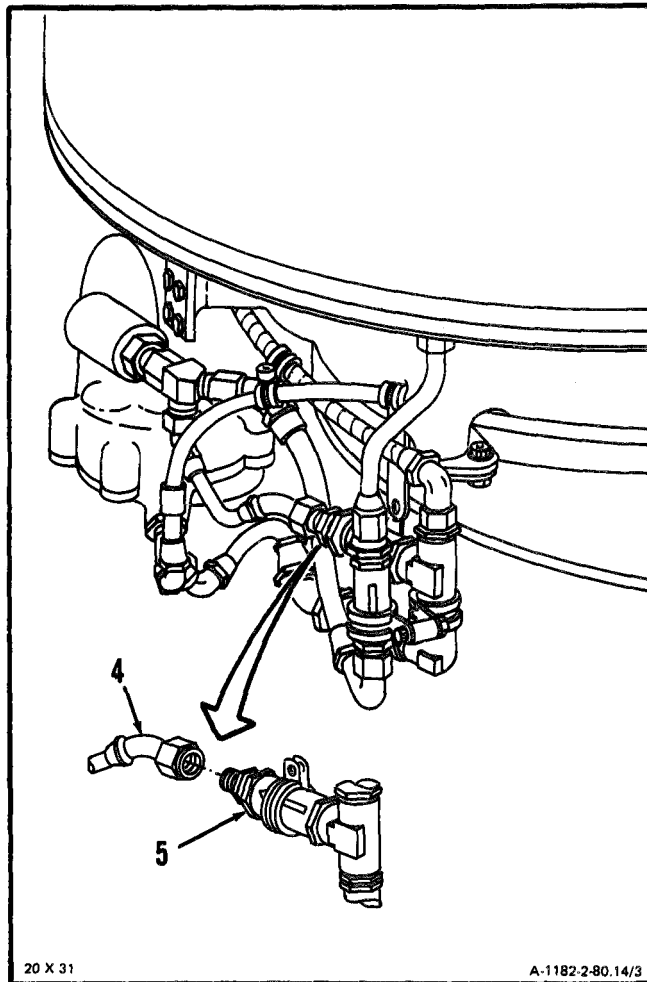
**GO TO NEXT PAGE**

2-80.14 REMOVE CHECK VALVE (WATER WASH TEE TO INTERSTAGE AIR-BLEED ACTUATOR P3 INLET) (Continued)

2-80.14

3. Remove check valve (5) from tee (6), and remove packing (7) from check valve (5).

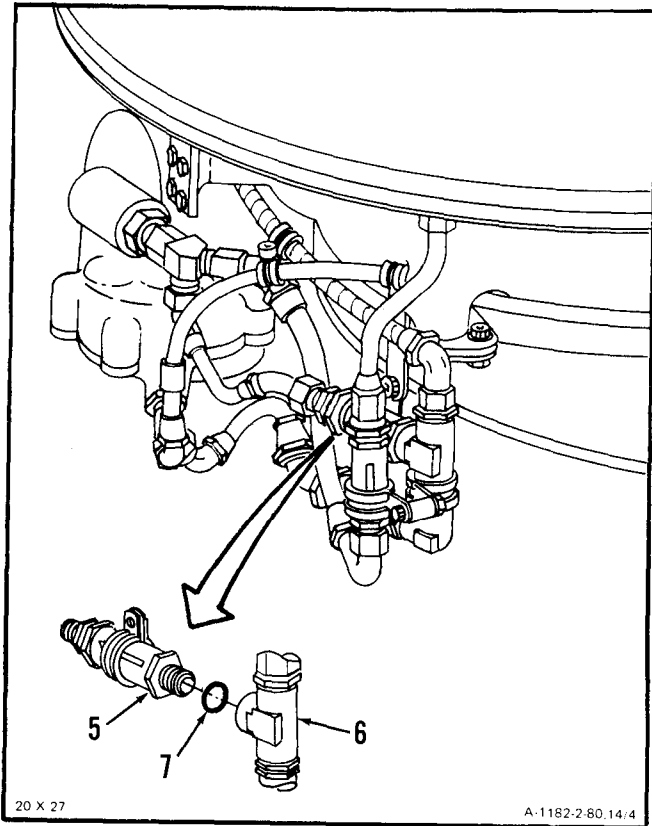

4. Remove clamp (8) from check valve (5).

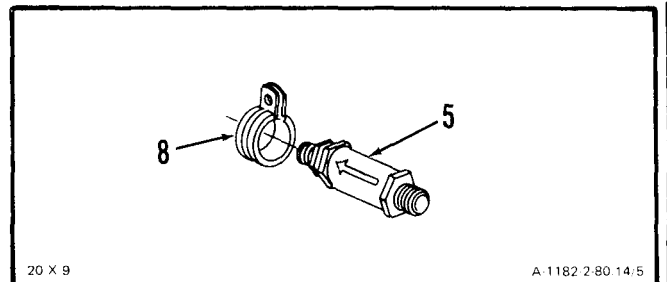

GO TO NEXT PAGE

**2-80.14 REMOVE CHECK VALVE (WATER WASH TEE TO INTERSTAGE
AIR-BLEED ACTUATOR P3 INLET) (Continued)**

2-80.14

FOLLOW-ON MAINTENANCE:

None

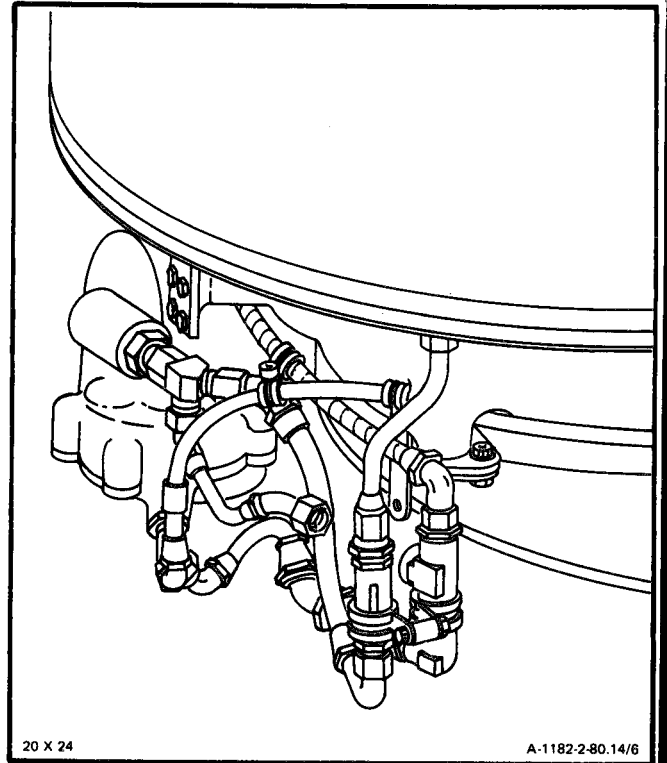
**END OF TASK**

2-80.15 CLEAN CHECK VALVE (WATER WASH TEE TO INTERSTAGE AIR-BLEED ACTUATOR P3 INLET)

2-80.15

INITIAL SETUP

Applicable Configurations:

All

Tools:

- Powerplant Mechanic's Tool Kit,
NSN 5180-00-3234944
- Goggles
- Compressed Air Source

Materials:

- Dry Cleaning Solvent (E17)
- Gloves (E20)

Personnel Required:

68B10 Aircraft Powerplant Repairer

Equipment Condition:

- Off Engine Task
- Check Valve (Air diffuser to interstage air-bleed actuator P3 inlet) (Task 2-80.14)

General Safety Instructions:

WARNING

Dry cleaning solvent (E17) is flammable and toxic. It can irritate skin and cause burns. Use only in well-ventilated area, away from heat and open flame. In case of contact, immediately flush skin or eyes with water for at least 15 minutes. Get medical attention for eyes.

1. Wear gloves (E20). **Clean check valve (1) and reducer (2)** using dry cleaning solvent (E17) and brush.

WARNING

When using compressed air for cleaning, use approved protective equipment for eyes and face. Do not use more than 30 psig air pressure. Do not direct air toward yourself or another person. Failure to comply could result in injury to eyes or skin. In case of injury, get medical attention.

2. Wear goggles. **Blow dry check valve (1) and reducer (2)**, using clean, dry compressed air.

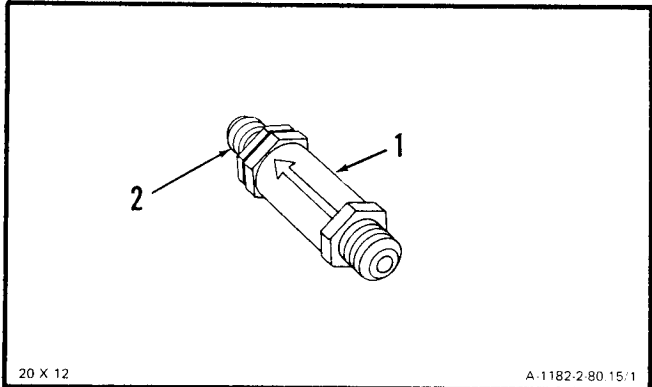

20 X 12

A-1182-2-80.15/1

FOLLOW-ON MAINTENANCE:

None

END OF TASK

**2-80.16 INSTALL CHECK VALVE (WATER WASH TEE TO INTERSTAGE
AIR-BLEED ACTUATOR P3 INLET)**

2-80.16

INITIAL SETUP

Applicable Configurations:

All

Tools:Powerplant Mechanic's Tool Kit,
NSN 5180-00-323-4944Technical Inspection Tool Kit,
NSN 5180-00-323-5114

Torque Wrench, 30-150 Inch-Pounds

Materials:

Lockwire (E29)

Personnel Required:

68B10 Aircraft Powerplant Repairer

68B30 Aircraft Powerplant Inspector

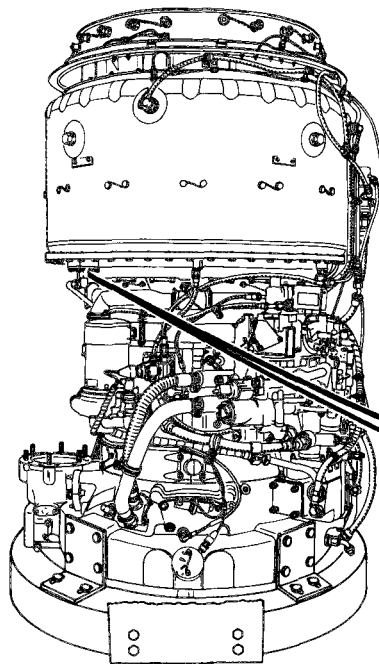

36 X 24

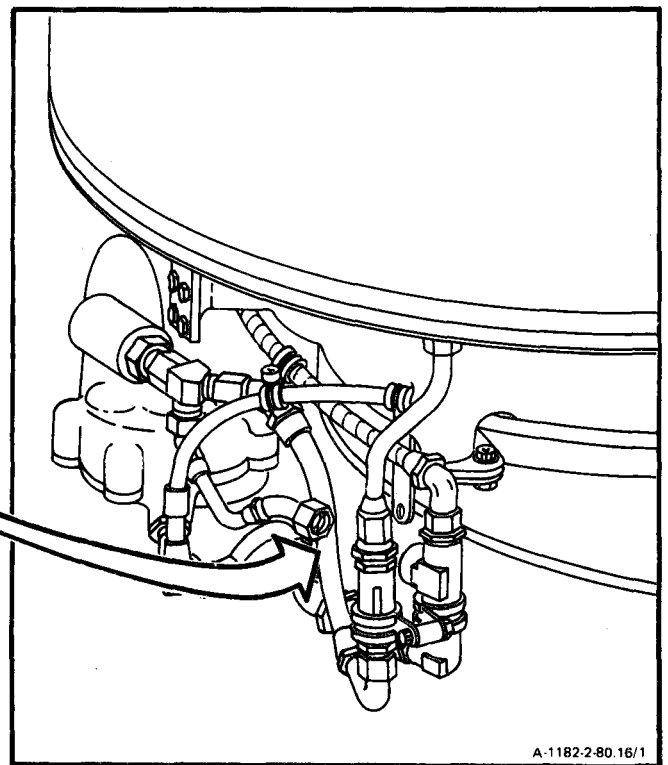

A-1182-2-80.16/1

GO TO NEXT PAGE

**2-80.16 INSTALL CHECK VALVE (WATER WASH TEE TO INTERSTAGE
AIR-BLEED ACTUATOR P3 INLET (Continued)**

2-80.16

NOTE

If check valve is a replacement do steps 1. and 2. If same check valve that was removed is to be installed, omit steps 1. and 2. and proceed to step 3.

1. **Remove reducer (1) and packing (2) from removed check valve (3).**
2. **Install packing (2) and reducer (1) in serviceable check valve (3).**

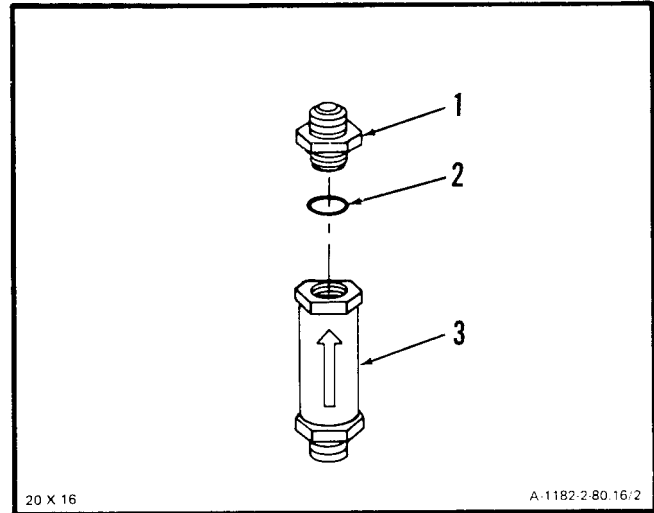
**GO TO NEXT PAGE**

2-80.16 INSTALL CHECK VALVE (WATER WASH TEE TO INTERSTAGE AIR-BLEED ACTUATOR P3 INLET) (Continued)

2-80.16

3. Install damp (4) on check valve (3).

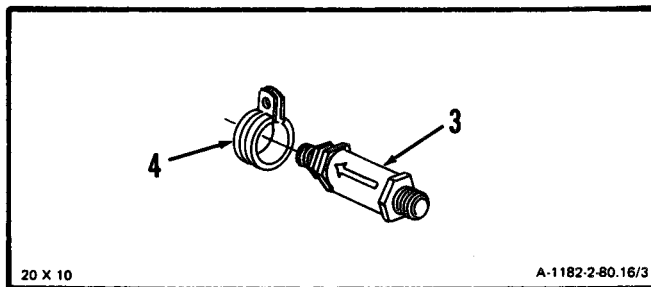

4. Install packing (5) on check valve (3).

CAUTION

In following step, when installing check valve, ensure arrow on check valve which indicates proper direction of airflow is positioned as shown in figure.

5. Install check valve (3) on tee (6).

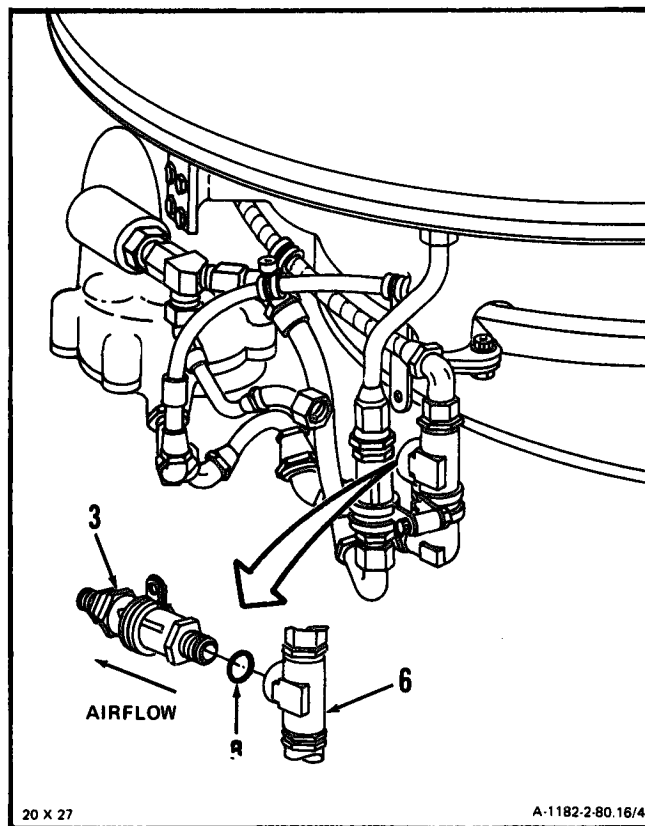

GO TO NEXT PAGE

**2-80.16 INSTALL CHECK VALVE (WATER WASH TEE TO INTERSTAGE
AIR-BLEED ACTUATOR P3 INLET) (Continued)**

2-80.16

6. Install hose assembly (7) on reducer (1).

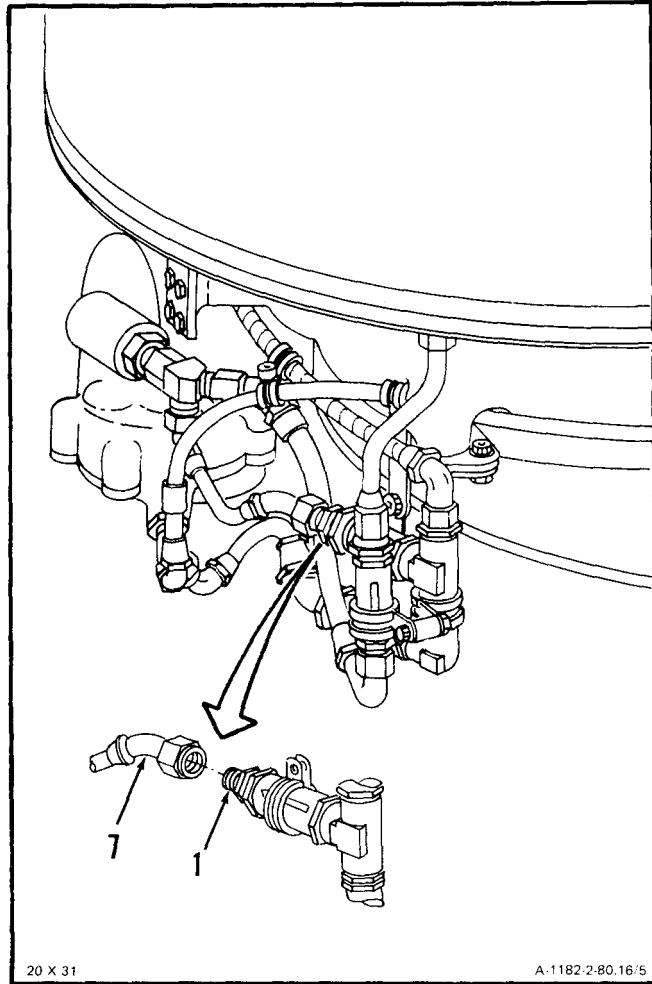

20 X 31

A-1182-2-80.16/5

GO TO NEXT PAGE

**2-80.16 INSTALL CHECK VALVE (WATER WASH TEE TO INTERSTAGE
AIR-BLEED ACTUATOR P3 INLET) (Continued)**

2-80.16

7. Install bolt (8) on clamp (4).
8. Using bolt (8), secure check valve (3) to bleed band retainer (9).
9. Torque tilt (8) to 65 inchpounds. Lockwire bolts. Use lockwire (E29).

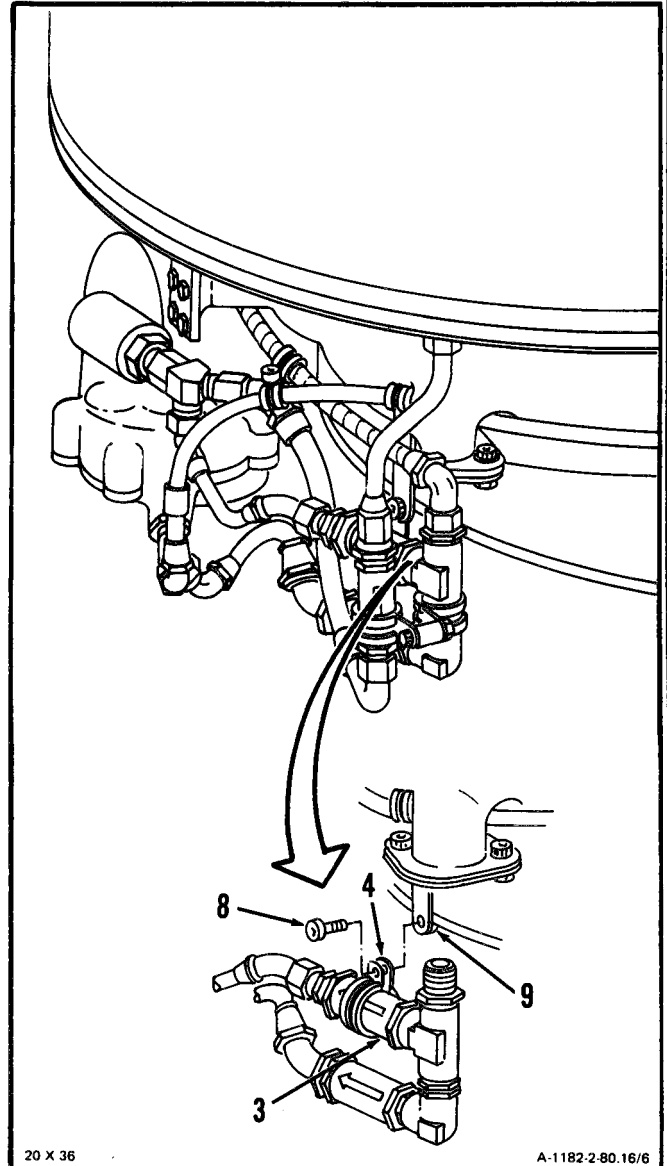

20 X 36

A-1182-2-80.16/6

INSPECT**GO TO NEXT PAGE**

**2-80.16 INSTALL CHECK VALVE (WATER WASH TEE TO INTERSTAGE
AIR-BLEED ACTUATOR P3 INLET) (Continued)**

2-80.16

FOLLOW-ON MAINTENANCE:

None

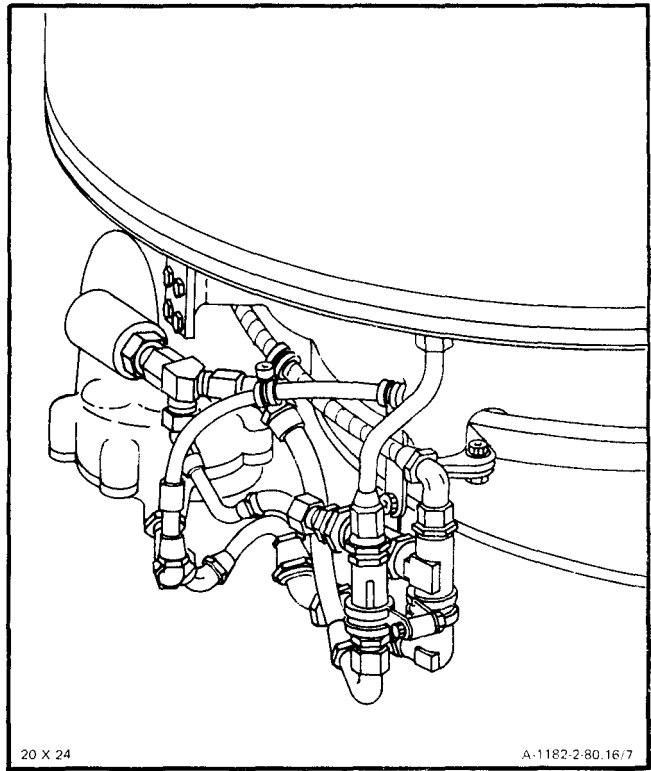

END OF TASK

2-80.17 REMOVE CHECK VALVE (WATER WASH TEE TO INTERSTAGE AIR-BLEED ACTUATOR FUEL CONTROL INLET)

2-80.17

INITIAL SETUP

Materials:
None

Applicable Configurations:
All

Personnel Required:
68B10 Aircraft Powerplant Repairer

Tools:
Powerplant Mechanic's Tool Kit,
NSN 5180-00-323-4944

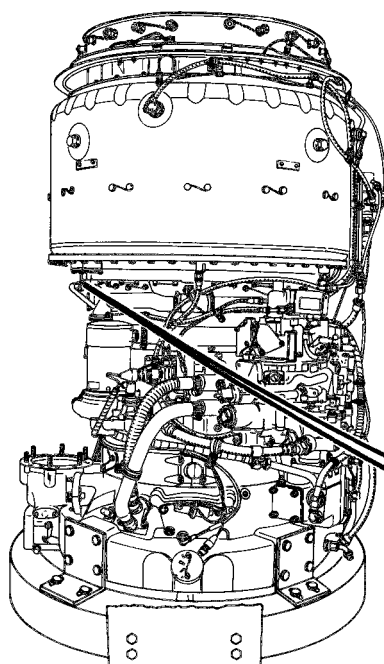

36 X 24

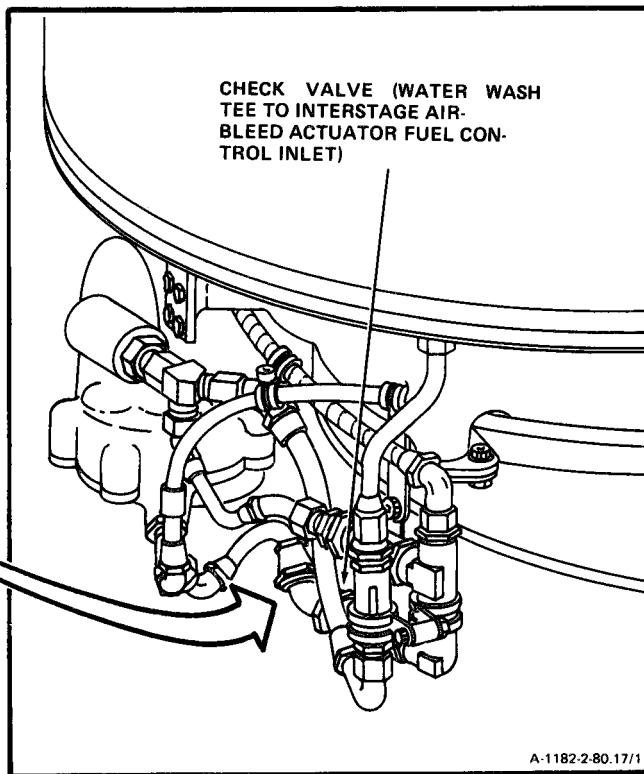

A-1182-2-80.17/1

GO TO NEXT PAGE

**2-80.17 REMOVE CHECK VALVE (WATER WASH TEE TO INTERSTAGE
AIR-BLEED ACTUATOR FUEL CONTROL INLET) (Continued)**

2-80.177

1. Remove nut (1), screw (2), and clamp (3).

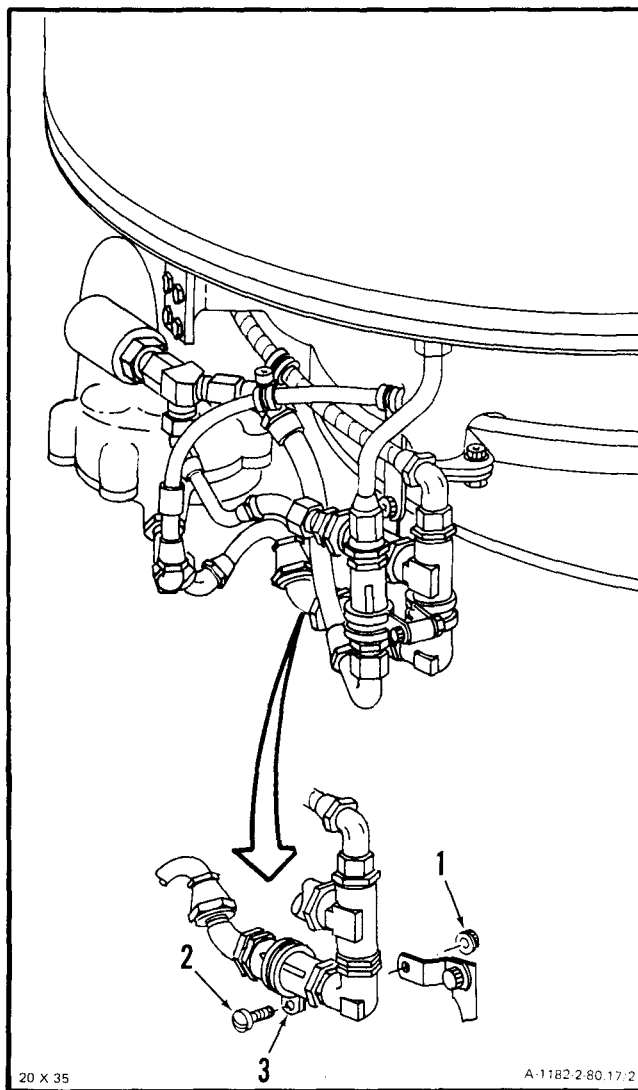

20 X 35

A-1182 2-80.17/2

GO TO NEXT PAGE

**2-80.17 REMOVE CHECK VALVE (WATER WASH TEE TO INTERSTAGE
AIR-BLEED ACTUATOR FUEL CONTROL INLET) (continued)**

2-80.17

2. Remove hose assembly (4) from check valve (5).

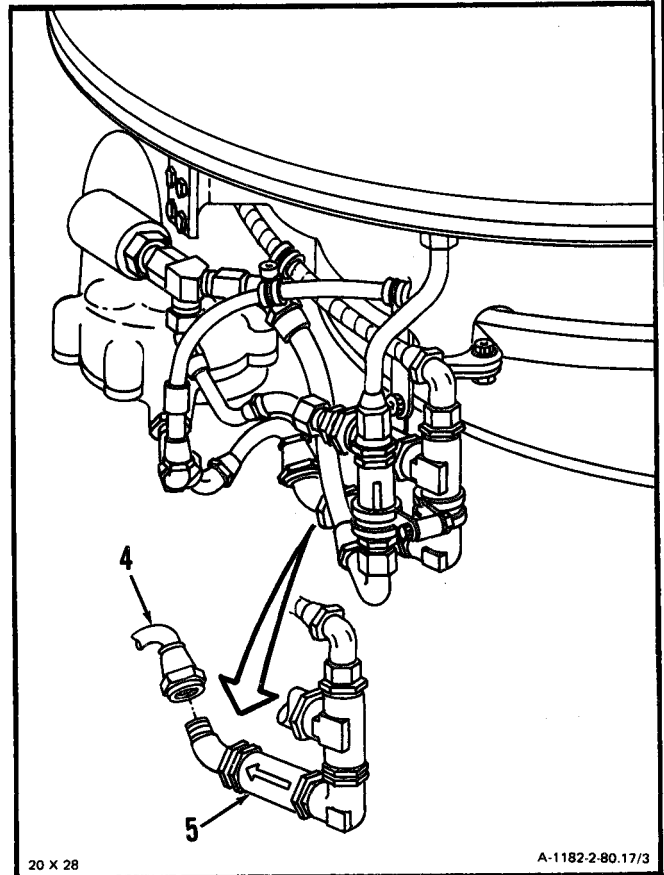
**GO TO NEXT PAGE**

2-80.17 REMOVE CHECK VALVE (WATER WASH TEE TO INTERSTAGE AIR-BLEED ACTUATOR FUEL CONTROL INLET) (Continued)

2-80.17

3. Remove check valve (5) from elbow (6).

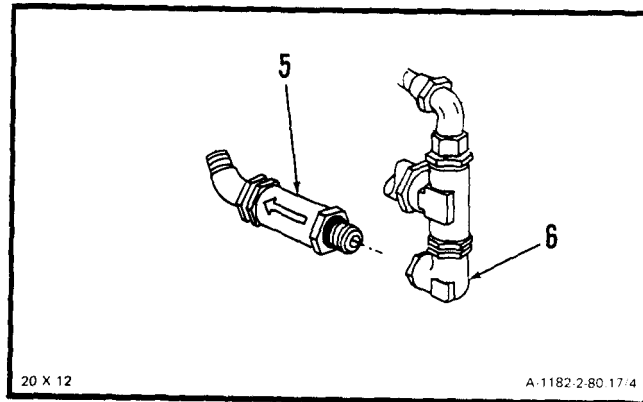

4. Remove packing (7) from check valve (5).

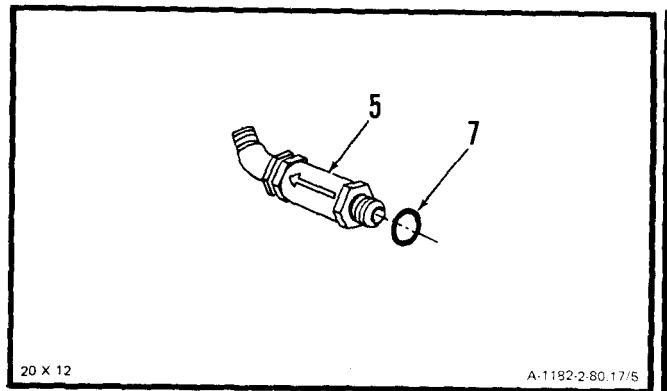

INSPECT

GO TO NEXT PAGE

**2-80.17 REMOVE CHECK VALVE (WATER WASH TEE TO INTERSTAGE
AIR-BLEED ACTUATOR FUEL CONTROL INLET) (Continued)**

2-80.17

FOLLOW-ON MAINTENANCE:

None

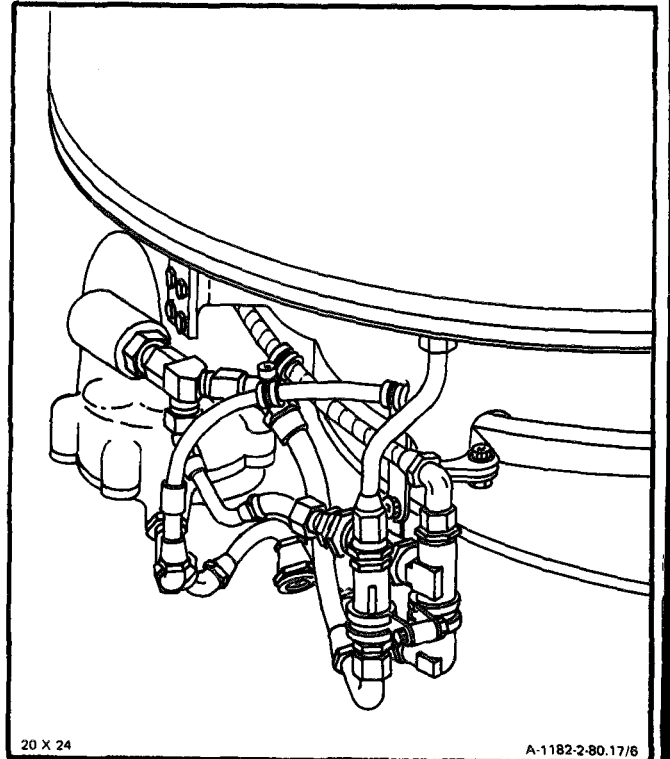

END OF TASK

2-80.18 CLEAN CHECK VALVE (WATER WASH TEE TO INTERSTAGE AIR-BLEED ACTUATOR FUEL CONTROL INLET) 2-80.18

INITIAL SETUP

Applicable Configurations:
All

Tools:

- Powerplant Mechanic's Tool Kit,
NSN 5180-00-323-4944
- Goggles
- Compressed Air Source

Materials:

- Dry Cleaning Solvent (E17)
- Gloves (E20)
- Lint-Free Cloth (E26)

Personnel Required:

68B10 Aircraft Powerplant Repairer

1. Wear gloves (E20). **Clean check valve (1) and elbow (2)** using dry cleaning solvent (E17) and brush.

WARNING

When using compressed air for cleaning, use approved protective equipment for eyes and face. Do not use more than **30 psig** air pressure. Do not direct air toward yourself or another person. Failure to comply could result in injury to eyes or skin. In case of injury, get medical attention.

2. Wear goggles. **Blow dry check valve (1) and elbow (2)** using clean, dry compressed air.

FOLLOW-ON MAINTENANCE:

None

END OF TASK

Equipment Condition:

Off Engine Task
Check Valve (water wash tee to interstage air-bleed actuator fuel control inlet) removed (Task 2-80.17)

General Safety Instructions:

WARNING

Dry cleaning solvent (E17) is flammable and toxic. It can irritate skin and cause burns. Use only in well-ventilated area, away from heat and open flame. In case of contact, immediately flush skin or eyes with water for at least **15 minutes**. Get medical attention for eyes.

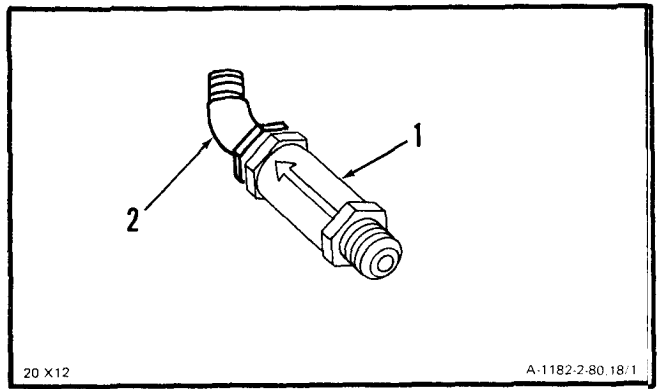

**2-80.19 INSTALL CHECK VALVE (WATER WASH TEE TO INTERSTAGE
AIR-BLEED ACTUATOR FUEL CONTROL INLET)**

2-80.19

INITIAL SETUP

Applicable Configurations:

All

Tools:

Powerplant Mechanic's Tool Kit,
NSN 5180-00-323-4944
Technical Inspection Tool Kit,
NSN 5180-00-323-5114

Materials:

None

Personnel Required:

68B10 Aircraft Powerplant Repairer
68B13 Aircraft Powerplant Inspector

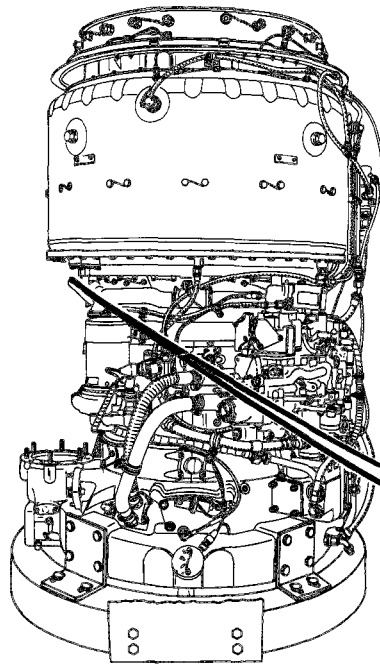

36 X 24

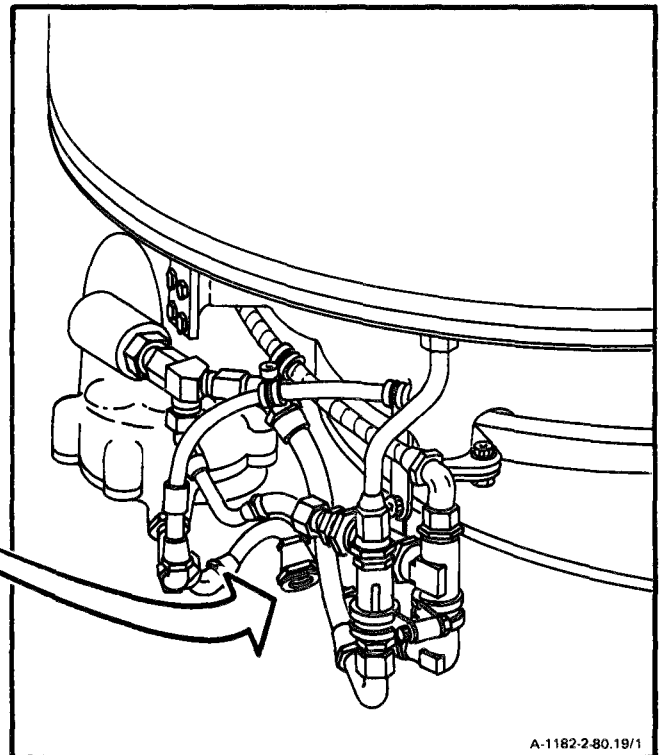

A-1182-2-80.19/1

GO TO NEXT PAGE

**2-80.19 INSTALL CHECK VALVE (WATER WASH TEE TO INTERSTAGE
AIR BLEED ACTUATOR FUEL CONTROL INLET) (Continued)**

2-80.19

N O T E

If check valve is a replacement do steps 1. and 2. If same check valve that was removed is to be installed, omit steps 1. and 2. and proceed to step 3.

1. **Remove elbow (1), nut (2), and packing (3) from removed check valve (4).**
2. **Loosely install nut (2) and packing (3) on elbow (1).** Position nut (2) to ensure packing (3) is in groove between two sets of threads on elbow (1).

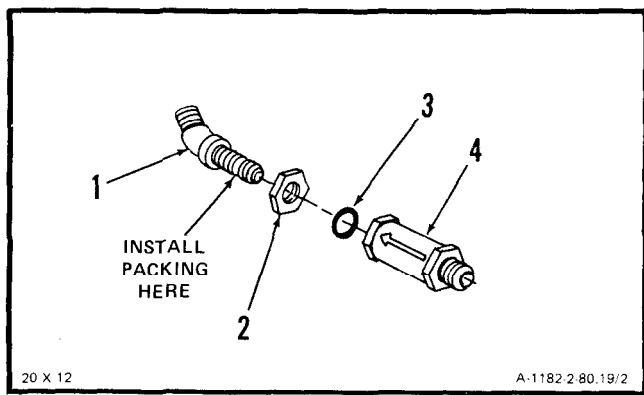
**GO TO NEXT PAGE**

**2-80.19 INSTALL CHECK VALVE (WATER WASH TEE TO INTERSTAGE
AIR-BLEED ACTUATOR FUEL CONTROL INLET) (Continued)**

2-80.19

3. Install packing (5) on check valve (4).

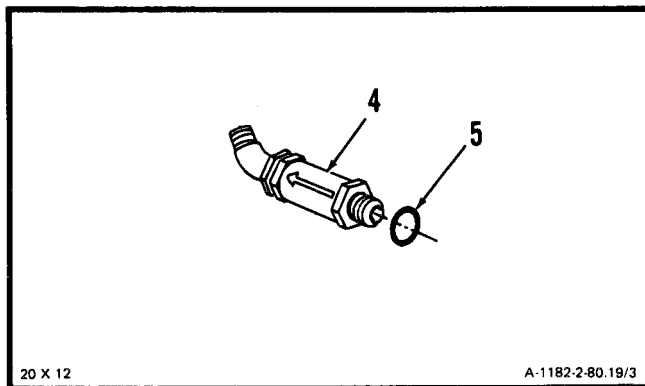
**CAUTION**

In following step, when installing check valve, ensure arrow on check valve which indicates airflow is positioned as shown in figure.

4. Install check valve (4) on elbow (6).

GO TO NEXT PAGE

**2-80.19 INSTALL CHECK VALVE (WATER WASH TEE TO INTERSTAGE
AIR-BLEED ACTUATOR FUEL CONTROL INLET) (Continued)**

2-80.19

6. Install hose assembly (7) on elbow (1).

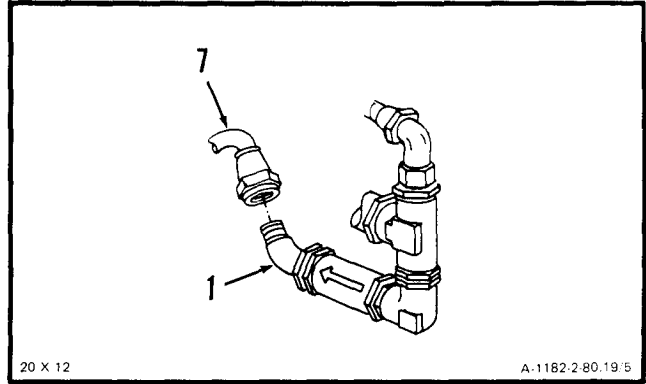

GO TO NEXT PAGE

**2-80.19 INSTALL CHECK VALVE (WATER WASH TEE TO INTERSTAGE
AIR-BLEED ACTUATOR FUEL CONTROL INLET) (Continued)**

2-80.19

7. Install clamp (8) on check valve (4), bracket (9), and install screw (10) and nut (11).

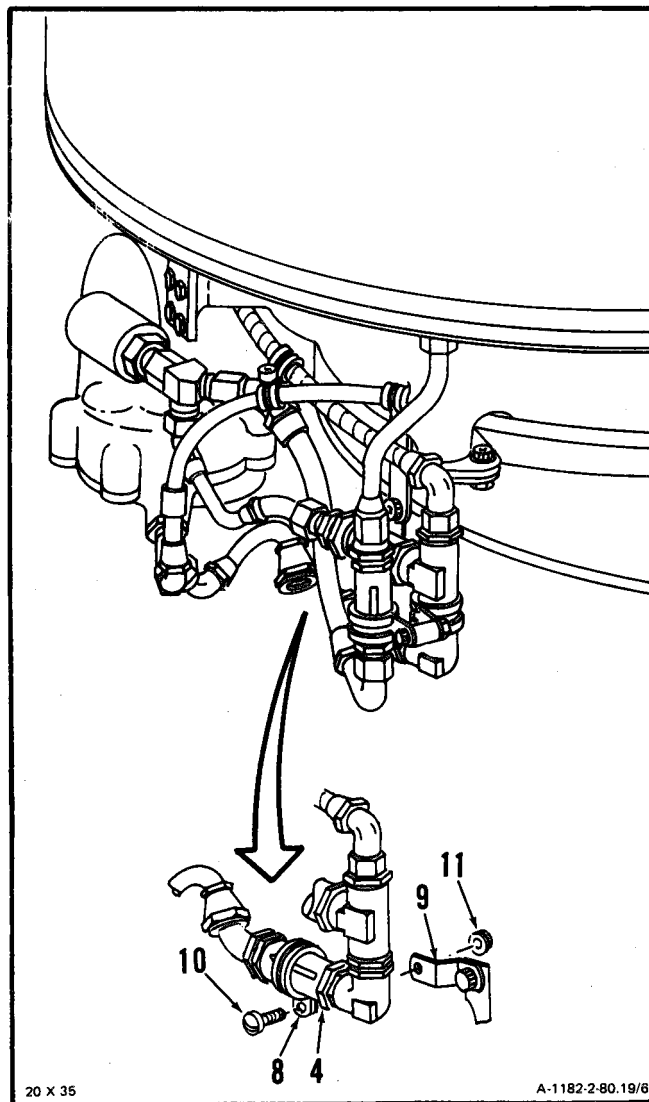

INSPECT

GO TO NEXT PAGE

**2-80.19 INSTALL CHECK VALVE (WATER WASH TEE TO INTERSTAGE
AIR-BLEED ACTUATOR FUEL CONTROL INLET) (Continued)**

2-80.19

FOLLOW-ON MAINTENANCE:

None

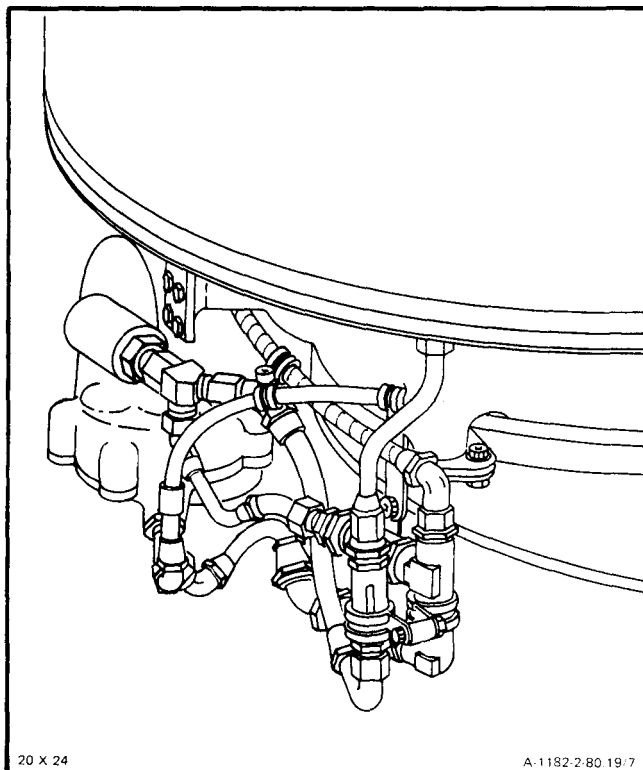

END OF TASK

INDEX

Subject	Para/ Task	Page	Subject	Para/ Task	Page
A					
Abbreviations		F-1	Adjust Fuel Control	1-108	1-526
Acceleration Checks	1-107	1-488	Adjust Fuel Control (AVIM)	1-109	1-538
Accessory Gear Assembly (AVIM)			Adjust Maximum Power	1-107	1-481
Clean	5-9	5-53	Adjust Maximum Trim	1-107	1-478
Inspect	5-10	5-54	Adjust Oil Pump	1-110	1-542
Install	5-11	5-56			
Remove	5-8	5-45	Air-Bleed Actuator, Interstage (With Water Wash Kit P/N 2-200-071-54 Installed) - (See Interstage Air-Bleed Actuator (With Water Wash Kit P/N 2-200-071-54 Installed))		
Accessory Gear Section	1-17	1-23	Air-Bleed Actuator, Interstage (Without Water Wash Kit PIN 2-200-071-54 Installed) - (See Interstage Air-Bleed Actuator (Without Water Wash Kit P/N 2-200-071-54 Installed))		
Accessory Gearbox Assembly			Air Diffuser Assembly		
Assemble	5-6	5-25	Clean (AVIM)	2-37	2-361
Clean	5-3	5-19	Inspect (AVIM)	2-38	2-363
Disassemble	5-2	5-13	Install (AVIM)	2-41	2-383
Inspect	5-4	5-22	Remove (AVIM)	2-36	2-51
Install	5-7	5-32	Repair (AVIM)	2-39	2-371
Remove	5-1	5-3	Repair	2-40	2-375
Repair	5-5	5-24	Air Gallery Cover, Antilcing - See Anti-Icing Air Gallery Cover		
Accessory Gearbox Chip Detector, Service - See Service Accessory Gearbox Chip Detector			Air Inlet Housing		
Activate Engine After Storage	1-27	1-88	Assembly		
Actuator, Interstage Air-Bleed (With Water Wash Kit P/N 2-200-071-54 Installed) - (See Interstage Air-Bleed Actuator (With Water Wash Kit P/N 2-200-071-54 Installed))			Clean	2-64	2-497
Actuator, Interstage Air-Bleed (Without Water Wash Kit P/N 2-200-071-54 Installed) - (See Interstage Air-Bleed Actuator (Without Water Wash Kit P/N 2-200-071-54 Installed))			Inspect	2-65	2-498
Adjust			Repair	2-66	2-499
Interstage Air-Bleed Actuator (With Water Wash Kit P/N 2-200-071-54 Installed)	2-8.1	2-40.1	Air Lines - See Hose Assembly		
Interstage Air-Bleed Actuator (Without Water Wash Kit P/N 2-200-071-54 Installed)	2-8	2-28	Alloys, Touch Up Magnesium and Magnesium - See Touch Up Magnesium and Magnesium Alloys		
			Anti-Icing Air Gallery Cover		
			Clean	2-15	2-55
			Inspect	2-16	2-58
			Install	2-18	2-62
			Remove	2-14	2-51
			Repair	2-17	2-60

INDEX (Continued)

Subject	Para/ Task	Page	Subject	Para/ Task	Page
Army Material to Prevent Enemy Use, Destruction of - See Destruction of Army Material to Prevent Enemy Use			Bearing Oil Filter, Service No. 4 and 5 - See Service No. 4 and 5 Bearing Oil Filter		
Assemble			Bearing Oil Tubes (AVIM), No. 4 and 5 - See No. 4 and 5 Bearing Oil Tubes (AVIM)		
Accessory Gearbox Assembly.....	5-6	5-25	Bearing Package (AVIM), Check for Seal Leakage (No. 2) - See Check for Seal Leakage (No. 2 Bearing Package) (AVIM)		
Chip Detector	8-93	8-295	Bearing Package (AVIM), No. 2 - See No. 2 Bearing Package (AVIM)		
Combustion Section	3-12	3-169	Bearing Package (AVIM), No. 3 - See No. 3 Bearing Package (AVIM)		
Combustion Section (AVIM).....	3-10	3-157	Bearing Package (AVIM) No. 4 and 5 - See No. 4 and 5 Bearing Package (AVIM)		
Combustion Section and Power Turbine (AVIM).....	3-7	3-77	Bearing Package Seals (AVIM), No. 4 and 5 - See No. 4 and 5 Bearing Package Seals (AVIM)		
Dual Chip Detector.....	8-33	8-85	Bearing Pressure Oil Strainer, No. 2 - See No. 2 Bearing Pressure Oil Strainer		
Fuel Control	6-5	6-19	Bearing Pressure Oil Strainer, Service No. 2 - See Service No. 2 Bearing Pressure Oil Strainer		
In-Line Fuel Filter Assembly.....	6-40	6-150	Blades, Compressor Rotor - See Compressor Rotor Blades		
Interstage Air-Bleed Actuator	2-6	2-19	Bleed Band Closure Check.....	1-107	1-470
Main Fuel Filter and Bracket	6-34	6-133	Bleed Band, Compressor - See Compressor Bleed Band		
No. 2 Bearing Package (AVIM)	2-46	2-417	Boost Pump Assembly, Fuel - See Fuel Boost Pump Assembly		
No. 3 Bearing Package (AVIM)	2-71	2-513	Bracket, Main Fuel Filter and - See Main Fuel Filter and Bracket		
Oil Cooler Assembly.....	8-10	8-33	Bus Bar Assemblies, Left- and Right- Hand - See Left- and Right-Hand Bus Bar Assemblies		
Oil Filter Assembly and Oil Filter Strainer	8-21	857			
Oil Level Float Assembly (AVIM).....	8-108	8-344			
Oil Level Indicator	8-100	8-315			
Output Shaft Support Housing (AVIM)....	2-62	2-484			
Overspeed Drive and Outlet Cover Assembly	5-22	5-110			
Third Turbine Nozzle and Support (AVIM).....	4-31	4-141			
Assurance/Quality Control (OA/QA), Quality - See Quality Assurance/ Quality Control (QA/QC)					
B					
Backlash Check - Overspeed Drive and Outlet Cover Assembly.....	5-23.1	5-116			
Band Closure Check, Bleed - See Bleed Band Closure Check					
Band, Compressor Bleed - See Compressor Bleed Band					
Bar Assemblies, Left- and Right-Hand Bus - See Left- and Right-Hand Bus Bar Assemblies					
Bearing (AVIM), Check for Seal Leakage (No. 4 and 5) - See Check for Seal Leakage (No. 4 and 5 Bearing (AVIM)					
Bearing Filter, No. 4 and 5 - See No. 4 and 5 Bearing Filter					

INDEX (Continued)

Subject	Para/ Task	Page	Subject	Para/ Task	Page
C					
Cable Assembly, Ignition Coil and- See Ignition Coil and Cable Assembly			Characteristics. Capabilities, and Features, Equipment - See Equipment Characteristics, Capabilities, and Features		
Cable Assembly, Main Electrical- See Main Electrical Cable Assembly			Chart. Maintenance Allocation - See Maintenance Allocation Chart		
Cap and Stem Assembly and Oil Filter Element, Oil Filter - See Oil Filter Cap and Stem Assembly and Oil Filter Element			Check, Bleed Band Closure - See Bleed Band Closure Check		
Cap and Stem Assembly and Oil Filter Element, Service Oil Filter - See Service Oil Filter Cap and Stem Assembly and Oil Filter Element			Check Engine Coastdown Time.....	1-81	1-245
Capabilities, and Features, Equipment, Characteristics - See Equipment Characteristics, Capabilities, and Features			Check, Flight Idle - See Flight Idle Check		
Care, and Handling, Safety - See Safety, Care, and Handling			Check for Seal Leakage (No. 2 Bearing Package) (AVIM).....	1-87	1-273
Case (AVIM), First Turbine Rotor - See First Turbine Rotor Case (AVIM)			Check for Seal Leakage (No. 4 and 5 Bearing) (AVIM)	1-88	1-283
Case (AVIM), Second Turbine Nozzle, Spacer, and - See Second Turbine Nozzle, Spacer, and Case			Check for Static Oil Leakage	1-89	1-300
Chafing, Denting, Scratching, Gouging, or Wear, Determine Depth of Damage from - See Determine Depth of Damage from Chafing, Denting, Scratching, Gouging, or Wear			Check Forty Percent Maximum Continuous Power - See Forty Percent Maximum Continuous Power Check		
Chafing Sleeve on Hoses, Install Spiral - See Install Spiral Chafing Sleeve on Hoses			Check Ground Idle - See Ground Idle Check		
Chamber Housing (AVIM), Combustion - See Combustion Chamber Housing (AVIM)			Check, Ground Idle Trim - See Ground Idle Trim Check		
Chamber Liner (AVIM), Combustion - See Combustion Chamber Liner (AVIM)			Check, Intermediate Power - See Intermediate Power Check		
Change from MIL-L-7808 to MIL-L- 23699 Lubricating Oil	1-76	1-234	Check, Maximum Continuous Power - See Maximum Continuous Power Check		
Change from MIL-L-23699 to MIL-L- 7808 Lubricating Oil	1-77	1-237	Check, Maximum Power- See Maximum Power Check		
			Check, N2 Governor Operation - See N2 Governor Operation Check		
			Check, Overspeed Drive and Outlet Cover Assembly, Backlash.....	-23.1	5-116
			Check Procedure, Prestart - See Prestart Check Procedure		
			Check Runs, Inspect Engine after - See Inspect Engine after Check Runs		

INDEX (Continued)

Subject	Para/ Task	Page	Subject	Para/ Task	Page
Check, Seventy-Five Percent Maximum Continuous Power - See Seventy-Five Percent Maximum Continuous Power Check			Clean (cont)		
Check Valve Assembly			Combustion Chamber Housing (AVIM).....	3-19	3-213
Clean.....	8-18.2	8-40.3	Combustion Chamber Liner (AVIM)	3-16	3-183
Inspect	8-18.3	8-40.2	Combustion Chamber Vane Assembly (AVIM)	3-13	3-171
Install	8-18.4	8-40.1	Compressor Bleed Band	2-10	2-44
Remove.....	8-18.1	8-40.1	Compressor Housing	2-21	2-144
Check Valve, Fuel - See Fuel Check Valve			Compressor Rotor Blades.....	2-32	2-278
Check, Vibration Meter - See Vibration Meter Check			Diffuser Curl	4-74	4-481
Check, Waveoff - See Waveoff Check			Dual Chip Detector	8-30	8-79
Checks, Acceleration - See Acceleration Checks			Exit Vane Assembly	4-79	4-494
Checks and Services, Preventive Maintenance - See Preventive Maintenance Checks and Services			Fireshield Assembly	4-13	4-69
Chip Detector			Fireshield Section	4-17	4-84
Assemble	8-93	8-295	First Turbine Disc Assembly (AVIM)	4-63	4-406
Clean.....	8-90	8-291	First Turbine Nozzle (AVIM).....	4-68	4-433
Disassemble	8-89	8-289	Flow Divider and Bracket	6-43	6-162
Inspect	8-91	8-293	Fourth Stage Power Turbine Nozzle (AVIM).....	4-46	4-271
Install	8-94	8-297	Fourth Stage Power Turbine Rotor (AVIM).....	4-34	4-158
Remove.....	8-88	8-287	Fuel Boost Pump Assembly.....	6-10	6--42
Test.....	8-92	8-294	Fuel Check Valve	6-47	6-173
Chip Detector, Accessory Gearbox, Service - See Service Accessory Gearbox Chip Detector			Fuel Control	63	6-14
Chip Detector Dual - See Dual Chip Detector			Fuel Drain Valve.....	3-2	3-6
Chip Detector, Dual Service - See Service Dual Chip Detector			Ignition Coil and Cable Assembly.....	7-2	7-30
Clean			Ignition Exciter.....	7-12	7-89
Accessory Gear Assembly (AVIM)	5-9	5-53	Inlet Housing Cover Assembly (AVIM).....	2-54	2-458
Accessory Gearbox Assembly.....	5-3	5-19	In-Line Fuel Filter Assembly.....	6-38	6-146
Air Diffuser Assembly (AVIM).....	2-37	2-361	Interstage Air-Bleed Actuator	2-3	2-14
Air Inlet Housing Assembly	2-64	2-497	Left- and Right-Hand Bus Bar Assemblies.....	4-8	4-42
Anti-Icing Air Gallery Cover	2-15	2-55	Left- and Right-Hand Fuel Manifold Assemblies	6-17	6-68
Check Valve Assembly.....	8-18.2	8-40.3	Main Electrical Cable Assembly (Nine Connector).....	7-17	7-111
Chip Detector	8-90	8-291	Main Electrical Cable Assembly (Six Connector)	7-17.1	7-112.1
			Main Fuel Filter and Bracket	6-31	6-126
			Main Oil Pump and Scavenge Oil Screen.....	8-2	8-12
			No. 2 Bearing Package (AVIM)	2-44	2-411
			No. 2 Bearing Pressure Oil Strainer	8-77	8-259
			No. 3 Bearing Package (AVIM)	2-69	2-508
			No. 4 and 5 Bearing Filter	8-81	8-269
			No. 4 and 5 Bearing Oil Tubes (AVIM).....	4-42	4-249
			No. 4 and 5 Bearing Package (AVIM)	4-38	4-198
			Oil Cooler Assembly.....	8-7	8-29

Subject	Para/ Task	Page	Subject	Para/ Task	Page
Clean (cont)			Combustion Chamber Housing (AVIM)		
Oil Drain Cock.....	8-85	8-281	Clean	3-19	3-213
Oil Filter Assembly and Oil Filter			Inspect	3-20	3-215
Strainer	8-18	8-52	Repair	3-21	3-217
Oil Filter Cap and Stem Assembly and			Combustion Chamber Liner (AVIM)		
Oil Filter Element.....	8-24	8-66	Clean.....	3-16	3-183
Oil Level Float Assembly (AVIM).....	8-105	8-340	Inspect	3-17	3-185
Oil Level Indicator	8-97	8-309	Repair	3-18	3-197
Oil Temperature Transmitter	8-13	8-43	Combustion Chamber Vane Assembly		
Output Shaft (AVIM).....	9-7	9-26	(AVIM)		
Output Shaft Seal and Housing			Clean.....	3-13	3-171
Assembly	2-49	2-436	Inspect	3-14	3-173
Output Shaft Support Housing (AVIM)....	2-60	2-478	Repair	3-15	3-180
Overspeed Drive and Outlet Cover			Combustion Section.....	1-15	1-19
Assembly	5-19	5-105	Combustion Section		
Primer Tube Assembly.....	6-22	6-104	Assemble	3-12	3-169
Second Turbine Disc Assembly			Assemble (AVIM)	3-10	3-157
(AVIM).....	4-54	4-320	Disassemble	3-11	3-168
Second Turbine Nozzle, Spacer, and			Disassemble (AVIM)	3-9	3-151
Case (AVIM)	4-58	4-345	Combustion Section and Power		
Spark Igniters.....	7-7	7-73	Turbine (AVIM)		
Start Fuel Nozzles.....	6-26	6-114	Assemble	3-7	3-77
Starter Drive Assembly	5-13	5-85	Disassemble	3-6	3-40
Starter Gearbox Filter.....	8-73 8-252		Install	3-8	3-116
Starting Fuel Solenoid Valve	6-50	6-181	Remove.....	3-5	3-11
Stator Vane Assemblies.....	2-27	2-228	Common Tools and Equipment.....	1-22	1-41
Thermocouple Harness Assemblies			Components, Location and Description		
(AVIM).....	4-21	4-102	of Major - See Location and Description of Major		
Thermocouple Jumper Lead.....	4-2	4-11	Components		
Third Stage Power Turbine Rotor			Compressor Bleed Band		
(AVIM).....	4-50	4-303	Clean.....	2-10	2-44
Third Turbine Nozzle and Support			Inspect	2-11	2-45
(AVIM).....	4-28	4-130	Install	2-13	2-47
Torquemeter Head Assembly (AVIM)	9-12	9-44	Remove.....	2-9	2-41
Torquemeter Junction Box (AVIM)	9-2	9-8	Repair	2-12	2-46
Clean, Inspect and Repair Splines					
and Gears	1-118	1630			
Closure Check, Bleed Band -					
See Bleed Band Closure Check					
Coastdown Time, Check Engine -					
See Check Engine Coastdown Time					
Coil and Cable Assembly, Ignition -					
See Ignition Coil and Cable Assembly					

INDEX (Continued)

Subject	Para/ Task	Page	Subject	Para/ Task	Page
Compressor Housing			Contaminated Fuel System, Inspect -		
Clean	2-21	2-144	See Inspect Contaminated Fuel		
Inspect	2-22	2-146	System		
Install Lower.....	2-25	2-178	Contaminated Oil System, Inspect -		
Install Upper.....	2-24	2-149	See Inspect Contaminated Oil		
Remove Lower.....	2-20	2-104	System		
Remove Upper.....	2-19	2-71	Continuous Power Check, Forty		
Repair	2-23	2-147	Percent Maximum - See Forty		
Compressor Rotor Blades			Percent Maximum Continuous		
Clean.....	2-32	2-278	Power Check		
Inspect	2-33	2-281	Continuous Power Check, Maximum		
Install	2-35	2-317	- See Maximum Continuous		
Remove.....	2-31	2-255	Power Check		
Repair	2-34	2-312	Continuous Power Check, Seventy-Five		
Compressor Section	1-14	1-15	Percent Maximum - See Seventy-		
Compressor Stall (Surge), Inspect Engine			Five Percent Maximum Continuous		
After- See Inspert Engine After			Power Check		
Compressor Stall (Surge)			Control, Adjust Fuel -		
Compressor Wash (With Water Wash Kit			See Adjust Fuel Control		
P/N 2-200-071-54 Installed) - See			Control, (AVIM) Adjust Fuel-		
Wash Compressor (With Water Wash			See Adjust Fuel Control (AVIM)		
Kit P/N 2-200-071-54 Installed)			Control, Fuel - See Fuel Control		
Compressor, Wash (Without Water Wash			Control Priming, Fuel- See		
Kit P/N 2-200-071-54 Installed) -			Fuel Control Priming		
See Wash Compressor (Without Water			Control (QAIQC), Quality Assurance/		
Wash Kit P/N 2-200-071-54 Installed)			Quality - See Quality Assurance/		
Container, Inspect Pressurized Shipping			Quality Control (QA/QC)		
and Storage - See Inspect Pressur-			Cooler Assembly, Oil -		
ized Shipping and Storage Container			See Oil Cooler Assembly		
Container, Install Engine into Shipping			Cover, Anti-Icing Air Gallery -		
and Storage - See Install Engine into			See Anti-Icing Air Gallery Cover		
Shipping and Storage Container			Cover Assembly (AVIM), Inlet Housing -		
Container, Mark Shipping and Storage -			See Inlet Housing Cover Assembly		
See Mark Shipping and Storage			(AVIM)		
Container			Curl (AVIM), Diffuser -		
Container, Prepare and Inspect Storage			See Diffuser Curl (AVIM)		
and Shipping - See Prepare and					
Inspect Storage and Shipping			D		
Container			Damage from Chafing, Denting,		
Container, Remove Engine from Ship-			Scratching, Gouging, or Wear,		
ping and Storage - See Remove			Determine Depth of - See		
Engine from Shipping and Storage			Determine Depth of Damage from		
Container			Chafing, Denting, Scratching,		
			Gouging, or Wear		

INDEX (Continued)

Subject	Para/ Task	Page	Subject	Para/ Task	Page
Data, Equipment - See Equipment Data			Diffuser Curl (AVIM)		
Data, Equipment Description-and - See Equipment Description and Data			Clean	4-74	4-481
Denting, Scratching, Gouging, or Wear, Determine Depth of Damage from Chafing - See Determine Depth of Damage from Chafing, Denting, Scratching, Gouging, or Wear			Inspect	4-75	4-483
Depth of Damage from Chafing, Denting, Scratching, Gouging, or Wear, Determine - See Determine Depth of Damage from Chafing, Denting, Scratching, Gouging, or Wear			Install	4-77	4-486
Description and Data, Equipment - See Equipment Description and Data			Remove.....	4-73	4-479
Description of Major Components, Location and - See Location and Description of Major Components			Repair	4-76	4-485
Designations, Official Nomenclature, Names and - See Official Nomenclature, Names, and Designations			Directional References	1-10	1-10
Destruction of Army Material to Prevent Enemy Use	1-3	1-2	Disassemble		
Detector, Chip - See Chip Detector			Accessory Gearbox Assembly.....	5-2	5-13
Detector, Dual Chip - See Dual Chip Detector			Chip Detector	8-89	8-289
Detector, Service Accessory Gearbox Chip - See Service Accessory Gearbox Chip Detector			Combustion Section	3-11	3-168
Detector, Service Dual Chip - See Service Dual Chip Detector			Combustion Section (AVIM).....	3-9	3-151
Determine Depth of Damage from Chafing, Denting, Scratching, Gouging, or Wear.....	1-120	1-646	Combustion Section and Power		
Diffuser Assembly (AVIM), Air - See Air Diffuser Assembly (AVIM)			Turbine (AVIM).....	3-6	3-40
			Dual Chip Detector.....	8-29	8-77
			Fuel Control	6-2	6-12
			In-Line Fuel Filter Assembly.....	6.37	6-144
			Interstage Air-Bleed Actuator	2-2	2-12
			Main Fuel Filter and Bracket	6-30	6-123
			No. 2 Bearing Package (AVIM)	2-43	2-402
			No. 3 Bearing Package (AVIM)	2-68	2-506
			Oil Cooler Assembly.....	8-6	8-26
			Oil Filler Assembly and Oil Filler		
			Strainer	8-17	8-50
			Oil Level Float Assembly (AVIM).....	8-104	8-339
			Oil Level Indicator	8-96	8-305
			Output Shaft Support Housing (AVIM).....	2-59	2-470
			Overspeed Drive and Outlet Cover Assembly	5-18	5-101
			Third Turbine Nozzle and Support (AVIM).....	4-27	4-128
			Disc Assembly (AVIM), First Turbine - See First Turbine Disc Assembly (AVIM)		
			Disc Assembly (AVIM), Second Turbine - See Second Turbine Disc Assembly (AVIM)		
			Divider and Bracket, Flow - See Flow Divider and Bracket		
			Drain Cock, Oil - See Oil Drain Cock		
			Drain Engine Oil System.....	1-75	1-226
			Drain Valve, Fuel - See Fuel Drain Valve		
			Drive Assembly, Starter - See Starter Drive Assembly		

INDEX (Continued)

Subject	Para/ Task	Page	Subject	Para/ Task	Page
Dropped Engine, Inspect - See Inspect Dropped Engine			Engine after N1 Overspeed (AVIM), Inspect - See Inspect Engine after N1 Overspeed (AVIM)		
Dual Chip Detector			Engine after N2 Overspeed (AVIM), Inspect - See Inspect Engine after N2 Overspeed (AVIM)		
Assemble	8-33	8-85	Engine after Power Turbine Overtorque (AVIM), Inspect - See Inspect Engine after Power Turbine Overtorque (AVIM)		
Clean.....	8-30	8-79	Engine after Storage, Activate - See Activate Engine after Storage		
Disassemble	8-29	8-77	Engine (AVIM), Test - See Test Engine (AVIM)		
Inspect	8-31	8-81	Engine Coastdown Time, Check - See Check Engine Coastdown Time		
Install	8-35	8-88	Engine for Shipment or Storage, Preserve and Prepare - See Preserve and Prepare Engine for Shipment or Storage		
Remove.....	8-28	8-73	Engine from Maintenance Stand, Remove - See Remove Engine from Maintenance Stand		
Repair	8-32	8-83	Engine from Shipping and Storage Container, Remove - See Remove Engine from Shipping and Storage Container		
Test.....	8-34	8-87	Engine Hot End (AVIM), Inspect - See Inspect Engine Hot End (AVIM)		
Dual Chip Detector, Service - See Service Dual Chip Detector			Engine Identification	1-107	1-525
E			Engine in Storage Over Six Months, Represerve - See Represerve Engine in Storage Over Six Months		
Electrical and Ignition System.....	1-19	1-32	Engine, Inspect Dropped - See Inspect Dropped Engine		
Electrical Cable Assembly, Main - See Main Electrical Cable Assembly			Engine into Shipping and Storage Container, Install - See Install Engine into Shipping and Storage Container		
Element, Oil Filter Cap and Stem Assembly and Oil Filter - See Oil Filter Cap and Stem Assembly and Oil Filter Element			Engine Maintenance Sling, Install- See Install Engine Maintenance Sling		
Element, Service Oil Filter Cap and Stem Assembly and Oil Filter - See Service Oil Filter Cap and Stem Assembly and Oil Filter Element			Engine Maintenance Sling, Remove - See Remove Engine Maintenance Sling		
Enemy Use, Destruction of Army Material to Prevent - See Destruction of Army Material To Prevent Enemy Use			Engine Oil System, Drain - See Drain Engine Oil System		
Engine	1	-13			
Engine after Check Runs, Inspect - See Inspect Engine after Check Runs					
Engine after Compressor Stall (Surge), Inspect - See Inspect Engine after Compressor Stall (Surge)					
Engine after Foreign Object Ingestion, Inspect - See Inspect Engine after Foreign Object Ingestion					

INDEX (Continued)

Subject	Para/ Task	Page	Subject	Para/ Task	Page
Engine Oil System, Service - See Service Engine Oil System			Field Replacement First and Second Turbine Disc Assembly (AVIM), Place in Service - See Place in Service Field Replacement First and Second Turbine Disc Assembly (AVIM)		
Engine on Maintenance Stand, Install - See Install Engine on Maintenance Stand			Filler Assembly and Oil Filler Strainer, Oil - See Oil Filler Assembly and Oil Filler Strainer		
Engine Rating.....	1-107	1-523	Filler Strainer, Oil Filler Assembly and Oil - See Oil Filler Assembly and Oil Filler Strainer		
Engine Starting Procedure.....	1-107	1-460	Filler Strainer, Service Oil - See Service Oil Filler Strainer		
Engine Serviceability, Inspect - See Inspect Engine Serviceability			Filter and Bracket, Main Fuel - See Main Fuel Filter and Bracket		
Engine Subjected to Excessive G-Loads, Inspect - See Inspect Engine Subjected to Excessive G-Loads			Filter Assembly, In-Line Fuel - See In- Line Fuel Filter Assembly		
Equipment Characteristics, Capabilities, and Features.....	1-8	1-3	Filter Cap and Stem Assembly and Oil Filter Element, Oil - See Oil Filter Cap and Stem Assembly and Oil Filter Element		
Equipment, Common Tools and - See Common Tools and Equipment			Filter Cap and Stem Assembly and Oil Filter Element, Service Oil- See Service Oil Filter Cap and Stem Assembly and Oil Filter Element		
Equipment Data	1-11	1-11	Filter Element, Oil Filter Cap and Stem Assembly and Oil - See Oil Filter Cap and Stem Assembly and Oil Filter Element		
Equipment Description and Data		1-3	Filter Element, Service Oil Filter Cap and Stem Assembly and Oil - See Service Oil Filter Cap and Stem Assembly and Oil Filter Element		
.Equipment Improvement Recommenda- tions (EIR), Reporting - See Reporting Equipment Improvement Recommen- dations (EIR)			Filter, No. 4 and 5 Bearing - See No. 4 and 5 Bearing Filter		
Excessive G-Loads, Inspect Engine Subjected to - See Inspect Engine Subjected to Excessive G-Loads			Filter, Service No. 4 and 5 Bearing Oil Filter - See Service No. 4 and 5 Bearing Oil Filter		
Exciter, Ignition - See Ignition Exciter			Filter, Service Starter Gearbox - See Service Starter Gearbox Filter		
Exit Vane Assembly			Firesheild Assembly		
Clean.....	4-79	4-494	Clean.....	4-13	4-69
Inspect	4-80	4-496	Inspect	4-14	4-71
Install	4-82	4-504	Install	4-15	4-72
Remove.....	4-78	4-489	Remove.....	4-12	4-65
Repair	4-81	4-501			
Expendable Supplies and Materials List.....		C-1			
F					
Features, Equipment Characteristics, Capabilities, and - See Equipment Characteristics, Capabilities, and Features					

INDEX (Continued)

Subject	Para/ Task	Page	Subject	Para/ Task	Page
Fireshield Section			Fourth Stage Power Turbine Nozzle (AVIM)		
Clean.....	4-17	4-84	Clean.....	4-46	4-27'
Inspect	4-18	4-86	Inspect	4-47	4-273
Install	4-19	4-87	Install	4-49	4-282
Remove.....	4-16	4-79	Remove.....	4-45	4-269
First and Second Turbine Disc Assembly (AVIM), Place in Service Field Replace- ment - See Place in Service Field Replacement First and Second Turbine Disc Assembly (AVIM)			Repair	4-48	4-280
First Turbine Disc Assembly (AVIM)			Fourth Stage Power Turbine Rotor (AVIM)		
Clean.....	4-63	4-406	Clean.....	4-34	4-158
Inspect	4-64	4-408	Inspect	4-35	4-160
Install	4-66	4-411	Install	4-36	4-164
Remove.....	4-62	4-397	Remove.....	4-33	4-151
Repair	4-65	4-410	Fuel Boost Pump Assembly		
First Turbine Nozzle (AVIM)			Clean.....	610	6-42
Clean.....	4-68	4-433	Inspect	6-11	6-43
Inspect	4-69	4-435	Install	6-13	6-48
Install	4-71	4-464	Package	6-15	6-56
Remove.....	4-67	4-429	Preserve	6-14	6-55
First Turbine Rotor Case (AVIM)			Remove.....	6-9	6-39
Repair	4-70	4-445	Repair	6-12	6-44
Flight Idle Check.....	1-107	1-468	Fuel Check Valve		
Float Assembly (AVIM), Oil Level - See Oil Level Float Assembly (AVIM)			Clean	6-47	6-173
Flow Divider and Bracket			Install	6-48	6-174
Clean.....	6-43	6-162	Remove	6-46	6-171
Inspect	6-44	6-164	Fuel Control		
Install	6-45	6-165	Assembly	6-5	6-19
Remove.....	6-42	6-159	Clean.....	6-3	6-14
Foreign Object Ingestion, Inspect Engine After - See Inspect Engine after Foreign Object Ingestion			Disassemble	6-2	6-12
Forms, Records and Reports, Mainte- nance - See Maintenance Forms, Records and Reports			Inspect	6-4	6-16
Forty Percent Maximum Continuous Power Check.....	1-107	1-505	Install	6-6	6-22
			Package	6-8	6-36
			Preserve	6-7	6-31
			Remove.....	6-1	6-5
			Repair	6-4.1	6-18.1
			Fuel Control, Adjust - See Adjust Fuel Control		
			Fuel Control (AVIM), Adjust - See Adjust Fuel Control (AVIM)		
			Fuel Control Priming.....	1-27	1-89

INDEX (Continued)

Subject	Para/ Task	Page	Subject	Para/ Task	Page
Fuel Drain Valve			Gearbox Filter, Service Starter - See Service Starter Gearbox Filter		
Clean.....	3-2	3-6	General Information.....	1-1	
Inspect	3-3	3-7	Glossary		Glossary-1
Install	3-4	3-8	Gouging, or Wear, Determine Depth of Damage from Chafing, Denting, Scratching - See Determining Depth of Damage from Chafing, Denting, Scratching, Gouging. or Wear		
Remove.....	3-1	3-3	Governor Operation Check, N2 - See N2 Governor Operation Check		
Fuel Filter and Bracket, Main - See Main Fuel Filter and Bracket			Ground Idle Check.....	1-107	1-463
Fuel Filter Assembly, In-Line - See In- Line Fuel Filter Assembly			Ground Idle Trim Check.....	1-107	1-487
Fuel Lines - See Hose Assembly and Tube Assembly					
Fuel Manifold Assemblies - See Left- and Right-Hand Fuel Manifold Assem- blies			H		
Fuel Nozzles, Start - See Start Fuel Nozzles			Handling, Safety, Care and - See Safety, Care, and Handling		
Fuel Solenoid Valve, Starting - See Starting Fuel Solenoid Valve			Harness Assemblies (AVIM), Thermo- couple - See Thermocouple Harness Assemblies (AVIM)		
Fuel System.....	1-18	1-28	Head Assembly (AVIM), Torquemeter- See Torquemeter Head Assembly (AVIM)		
Fuel System, Inspect Contaminated- See Inspect Contaminated Fuel System			Hoisting	1-109	
G			Hose Assembly (Air Diffuser Assembly to Fuel Control)		
G-Loads, Inspect Engine Subjected to Excessive - See Inspect Engine Subjected to Excessive G-Loads			Install	2-80	2-553
Gallery Cover, Anti-Icing Air - See Anti- Icing Air Gallery Cover			Remove.....	2-79	2-550
Gear Assembly (AVIM), Accessory - See Accessory Gear Assembly (AVIM)			Hose Assembly (Compressor Housing to Inlet Housing)		
Gear Section, Accessory - See Acces- sory Gear Section (AVIM)			Install	2-78	2-543
Gears, Clean, Inspect and Repair Splines and - See Clean, Inspect and Repair Splines and Gears			Remove.....	2-77	2-536
Gearbox Assembly, Accessory - See Accessory Gearbox Assembly			Hose Assembly (Dual Chip Detector to Accessory Gearbox Assembly)		
Gearbox Chip Detector Service, Acces- sory - See Service Accessory Gearbox Chip Detector			Install	8-43	8-113
			Remove.....	8-42	8-107
			Hose Assembly (Dual Chip Detector to Accessory Gearbox Collector)		
			Install	8-45	8-123
			Remove	8-44	8-118

INDEX (Continued)

Subject	Para/ Task	Page	Subject	Para/ Task	Page
Hose Assembly (Dual Chip Detector to Air Diffuser Assembly)			Hose Assembly (Inlet Housing to Oil Scavenge Tee)		
Install	8-47	8-131	Install	8-61	8-207
Remove.....	8-46	8-128	Remove.....	8-60	8-204
Hose Assembly (Flow Divider Left Side Primary to Manifold Assembly)			Hose Assembly (In-Line Fuel Filter to Flow Divider)		
Install	6-65	6-225	Install	6-59	6-203
Remove.....	6-64	6-223	Remove ;.....	6-58	6-199
Hose Assembly (Flow Divider Left Side Secondary to Manifold Assembly)			Hose Assembly (Interstage Air-Bleed Actuator to Air Diffuser Assembly)		
Install	6-69	6234	Install	2-76	2-534
Remove.....	6-68	6231	Remove.....	2-75	2-532
Hose Assembly (Flow Divider Right Side Primary to Manifold Assembly)			Hose Assembly (Interstage Air-Bleed Actuator to Fuel Control)		
Install	6-67	6-229	Install	2-74	2-528
Remove.....	6-66	6-227	Remove.....	2-73	2-525
Hose Assembly (Flow Divider Right Side Secondary to Manifold Assembly)			Hose Assembly (Main Fuel Filter to Fuel Control)		
Install	6-71	6-240	Install	6-73	6-247
Remove.....	6-70	6237	Remove.....	6-72	6-244
Hose Assembly (Fuel Boost Pump to Main Fuel Filter)			Hose Assembly (Main Oil Pump to Dual Chip Detector)		
Install	6-61	6-210	Install	8-49	8-135
Remove.....	660	6-206	Remove	8-48	8-133
Hose Assembly (Fuel Check Valve to Fuel Boost Pump)			Hose Assembly (Main Oil Pump to Inlet Housing Oil Scavenge Tee)		
Install	6-63	6-218	Install	8-53	8-152
Remove.....	6-62	6-214	Remove	8-52	8-148
Hose Assembly (Fuel Control to Oil Cooler)			Hose Assembly (Main Oil Pump to No. 4 and 5 Bearing Scavenge Tube Assembly)		
Install	6-57	6-196	Install	8-55	8-159
Remove.....	6-56	6-193	Remove.....	8-54	8-156
Hose Assembly (Fuel Control to Starting Fuel Solenoid Valve)			Hose Assembly (Accessory Gearbox Assembly to Check Valve Assembly)		
Install	6-75	6-253	Install	8-39	8-100
Remove.....	6-74	6-250	Remove.....	8-38	8-97
Hose Assembly (Inlet Housing to Oil Drain Cock)			Hose Assembly (Oil Cooler to Inlet Housing)		
Install	8-63	8-215	Install	8-37	8-95
Remove.....	8-62	8-209	Remove.....	8-36	8-93

INDEX (Continued)

Subject	Para/ Task	Page	Subject	Para/ Task	Page
Hose Assembly (Oil Cooler to In-Line Fuel Filter)			Hose Assembly (Water Wash Kit Installation to Interstage Airframe Quick Disconnect Shelf)		
Install	6-55	6-191	Install	2-80.10	
Remove.....	6-54	6-189	Remove.....	2-80.9	
Hose Assembly (Oil Cooler to Pressure Connector)			Hoses, Install Spiral Chafing Sleeve on - See Install Spiral Chafing Sleeve on Hoses		
Install	8-41	8-105			
Remove.....	8-40	8-103			
Hose Assembly (Oil Filler to Starter Drive)			Hot End (AVIM), Inspect Engine - See Inspect Engine Hot End (AVIM)		
Install	8-65	8-224	Housing Assembly (AVIM), Air Inlet - See Air Inlet Housing Assembly (AVIM)		
Remove.....	8-64	8-221			
Hose Assembly (Pressure Connector to No. 4 and 5 Bearing Filter)			Housing Assembly, Output Shaft Seal and - See Output Shaft Seal and Housing Assembly		
Install	8-59	8-191			
Remove.....	8-58	8-178	Housing (AVIM), Combustion Chamber- See Combustion Chamber Housing(AVIM)		
Hose Assembly (Starter Drive to Tube and Hose Assembly)			Housing (AVIM), Output Shaft Support - See Output Shaft Support Housing (AVIM)		
Install	8-67	8-229			
Remove.....	8-66	8226			
Hose Assembly (Starting Fuel Solenoid Valve to Tube Assembly)			Housing, Compressor - See Compressor Housing		
Install	6-77	6-259			
Remove.....	6-76	6-256	Housing Cover Assembly (AVIM), Inlet - See Inlet Housing Cover Assembly (AVIM)		
Hose Assembly (Water Wash Check Valve Elbow to Interstage Air-Bleed Actuator TIC Inlet)			I		
Install	2-80.8		Identification, Engine - See Engine Identification		
Remove.....	2-0.7				
Hose Assembly (Water Wash Check Valve Reducer to Interstage Air-Bleed Actuator P3 Inlet)			Idle Check, Flight - See Flight Idle Check		
Install	2-80.4		Idle Check, Ground - See Ground Idle Check		
Remove.....					
Hose Assembly (Water Wash Tee Check Valve to Interstage Air-Bleed Actuator P3 Inlet)			Idle Trim Check, Ground - See Ground Idle Trim Check		
Install	2-80.6				
Remove.....	2-0.5		Igniters, Spark - See Spark Igniters		
			Ignition Coil and Cable Assembly		
			Clean.....	7-2	7-30
			Inspect	7-3	7-32
			Install	7-5	7-41
			Remove.....	7-1	7-3
			Repair	7-4	7-35

INDEX (Continued)

Subject	Para/ Task	Page	Subject	Para/ Task	Page
Ignition Exciter			Inspect (cont)		
Clean.....	7-12	7-89	Air Inlet Housing Assembly	2-65	2-498
Inspect	7-13	7-91	Check Valve Assembly.....	8-183	8-40.4
Install	7-15	7-94	Anti-Icing Air Gallery Cover	2-16	2-58
Remove.....	7-11	7-85	Chip Detector	8-91	8-293
Repair	7-14	7-92	Combustion Chamber Housing (AVIM).....	3-20	3-215
Ignition System - Electrical and - See Electrical and Ignition System			Combustion Chamber Liner (AVIM).....	3-17	3-185
Illustrated List of Manufactured Items		E-1	Combustion Chamber Vane Assembly (AVIM)	3-14	3-173
Improvement Recommendations (EIR), Reporting Equipment - See Reporting Equipment Improvement Recommen- dations (EIR)			Compressor Bleed Band	2-11	2-45
Index, Symptom - See Symptom Index			Compressor Housing	2-22	2-146
Indicator, Oil Level - See Oil Level Indicator			Compressor Rotor Blades	2-33	2-281
Information, General - See General Information			Diffuser Curl.....	4-75	4-483
Ingestion, Inspect Engine after Foreign Object - See Inspect Engine after Foreign Object Ingestion			Dual Chip Detector.....	8-31	8-81
Inlet Housing Assembly (AVIM), Air - See Air Inlet Housing Assembly (AVIM)			Exit Vane Assembly	4-80	4-496
Inlet Housing Cover Assembly (AVIM)			Fireshield Assembly	4-14	4-71
Clean.....	2-54	2-458	Fireshield Section.....	4-18	4-86
Inspect	2-55	2-459	First Turbine Disc Assembly (AVIM)	4-64	4-408
Install	2-57	2-461	First Turbine Nozzle (AVIM).....	4-69	4-435
Remove.....	2-53	2-455	Flow Divider and Bracket	6-44	6-164
Repair	2-56	2-460	Fourth Stage Power Turbine Nozzle (AVIM).....	4-47	4-273
In-Line Fuel Filter Assembly			Fourth Stage Power Turbine Rotor (AVIM).....	4-35	4-160
Assemble	6-40	6-150	Fuel Boost Pump Assembly	6-11	6-43
Clean.....	6-38	6-146	Fuel Control	6-4	6-16
Disassemble	6-37	6-144	Fuel Drain Valve.....	3-3	3-7
Inspect	6-39	6-148	Ignition Coil and Cable Assembly.....	7-3	7-32
Install	6-41	6-153	Ignition Exciter.....	7-13	7-91
Remove.....	6-36	6-141	Inlet Housing Cover Assembly (AVIM).....	2-55	2-459
Inspect			In-Line Fuel Filter Assembly.....	6-39	6-148
Accessory Gear Assembly (AVIM)	5-10	5-54	Interstage Air-Bleed Actuator	2-4	2-16
Accessory Gearbox Assembly.....	5-4	5-22	Left- and Right-Hand Bus Bar Assemblies.....	4-9	4-43
Air Diffuser Assembly (AVIM).....	2-38	2-363	Left- and Right-Hand Fuel Manifold Assemblies.....	6-18	6-70
			Main Electrical Cable Assembly (Nine Connector)	7-18	7-113
			Main Electrical Cable Assembly (Six Connector).....	7-18.1	7-114.1
			Main Fuel Filter and Bracket	6-32	6-128
			Main Oil Pump and Scavenge Oil Screen.....	8-3	8-14
			No. 2 Bearing Package (AVIM)	2-45	2-414
			No. 2 Bearing Pressure Oil Strainer	8-78	8-260
			No. 3 Bearing Package (AVIM)	2-70	2-511
			No. 4 and 5 Bearing Filter	8-82	8-270
			No. 4 and 5 Bearing Oil Tubes (AVIM).....	4-43	4-250

INDEX (Continued)

Subject	Para/ Task	Page	Subject	Para/ Task	Page
Inspect (cont)			Inspect Engine Serviceability	1-85.1	1-262 1
No. 4 and 5 Bearing Package (AVIM).....	4-39	4-200	Inspect Engine after Compressor Stall (Surge).....	1-90	1-306
Oil Cooler Assembly.....	8-8	8-31	Inspect Engine after Foreign Object Ingestion	1-92	1-309
Oil Drain Cock.....	8-86	8-283	Inspect Engine after N1 Overspeed (AVIM).....	1-79	1-241
Oil Filler Assembly and Oil Filler Strainer	8-19	8-54	Inspect Engine after N2 Overspeed (AVIM).....	1-80	1-243
Oil Filter Cap and Stem Assembly and Oil Filter Element.....	8-25	8-68	Inspect Engine after Power Turbine Overtorque (AVIM).....	1-84	1-253
Oil Level Float Assembly (AVIM).....	8-106	8-342	Inspect Engine Hot End (AVIM).....	1-93	1-313
Oil Level Indicator	8-98	8-311	Inspect Engine Subjected to Excessive G-Loads	1-82	1-247
Oil Temperature Transmitter	8-14	8-44	Inspect Pressurized Shipping and Storage Container	1-25	1-45
Output Shaft (AVIM).....	9-8	9-28	Inspect Shipping and Storage Container, Prepare and - See Prepare and Inspect Shipping and Storage Container		
Output Shaft Seal and Housing Assembly	2-50	2-437	Inspections, Special - See Special Inspections		
Output Shaft Support Housing (AVIM)....	2-61	2-481	Install		
Overspeed Drive and Outlet Cover Assembly	5-20	5-107	Accessory Gear Assembly (AVIM)	5-11	5-56
Primer Tube Assembly.....	6-23	6-106	Accessory Gearbox Assembly.....	5-7	5-32
Second Turbine Disc Assembly (AVIM).....	4-55	4-322	Air Diffuser Assembly (AVIM).....	2-41	2-383
Second Turbine Nozzle, Spacer, and Case (AVIM).....	4-59	4-347	Anti-Icing Air Gallery Cover	2-18	2-62
Spark Igniters.....	7-8	7-74	Check Valve Assembly.....	8-18.4	8-40.5
Start Fuel Nozzles.....	6-27	6-115	Chip Detector	8-94	8-297
Starter Drive Assembly	5-14	5-86	Combustion Section and Power Turbine (AVIM).....	3-8	3-116
Starter Gearbox Filter.....	8-74	8-253	Compressor Bleed Band	2-13	2-47
Starting Fuel Solenoid Valve.....	6-51	6-182	Compressor Rotor Blades.....	2-35	2-317
Stator Vane Assemblies.....	2-28	2-230	Diffuser Curl.....	4-77	4-486
Thermocouple Harness Assemblies (AVIM).....	4-22	4-103	Dual Chip Detector.....	8-35	8-88
Thermocouple Jumper Lead.....	4-3	4-12	Exit Vane Assembly	4-82	4-504
Third Stage Power Turbine Rotor (AVIM).....	4-51	4-305	Fireshield Assembly	4-15	4-72
Third Turbine Nozzle and Support (AVIM).....	4-29	4-132	Fireshield Section.....	4-19	4-87
Torquemeter Head Assembly (AVIM)	9-13	9-46	First Turbine Disc Assembly (AVIM)	4-66	4-411
Torquemeter Junction Box (AVIM)	9-3	9-9	First Turbine Nozzle (AVIM).....	4-71	4-464
Inspect and Repair Splines and Gears, Clean - See Clean, Inspect and Repair Splines and Gears			Flow Divider and Bracket	6-45	6-165
Inspect Contaminated Fuel System	1-85	1-255	Fourth Stage Power Turbine Nozzle (AVIM).....	4-49	4-282
Inspect Contaminated Oil System.....	1-86	1-264			
Inspect Dropped Engine	1-83	1-249			
Inspect Engine after Check Runs	1-91	1-308			

INDEX (Continued)

Subject	Para/ Task	Page	Subject	Para/ Task	Page
Install (cont)			Install (cont)		
Fourth Stage Power Turbine Rotor (AVIM).....	4-36	4-164	Hose Assembly (Main 011 Pump to Inlet Housing Oil Scavenge Tee).....	8-53	8-152
Fuel Boost Pump Assembly -	6-13	6-48	Hose Assembly (Main Oil Pump to No. 4 and 5 Bearing Scavenge Tube Assembly)	8-55	8-159
Fuel Check Valve	6-48	6-174	Hose Assembly (Accessory Gearbox Assembly to Check Valve Assembly)	8-39	8-100
Fuel Control	6-6	6-22	Hose Assembly (Oil Cooler to Inlet Housing).....	8-37	8-95
Fuel Drain Valve.....	3-4	3-8	Hose Assembly (Oil Cooler to In-Line Fuel Filter).....	6-55	6-191
Hose Assembly (Ar Diffuser Assembly to Fuel Control).....	2-80	2-553	Hose Assembly (Oil Cooler to Pressure Connector).....	8-41	8-105
Hose Assembly (Compressor Housing to Inlet Housing).....	2-78	2-543	Hose Assembly (Oil Filter to Starter Drive)	8-65	8-224
Hose Assembly (Dual Chip Detector to Accessory Gearbox Assembly)	8-43	8-113	Hose Assembly (Pressure Connector to No. 4 and 5 Bearing Filter)	8-59	8-191
Hose Assembly (Dual Chip Detector to Accessory Gearbox Collector).....	8-45	8-123	Hose Assembly Starter Drive to Tube and Hose Assembly).....	8-67	8-229
Hose Assembly (Dual Chip Detector to Air Diffuser Assembly).....	8-47	8-131	Hose Assembly (Starting Fuel Solenoid Valve to Tube Assembly).....	6-77	6-259
Hose Assembly (Flow Divider Left Side Primary to Manifold Assembly)	6-65	6-225	Hose Assembly (Water Wash Check Valve Elbow to Interstage Air-Bleed Actuator T/C Inlet).....	2-80.8	
Hose Assembly (Flow Divider Left Side Secondary to Manifold Assembly)	6-69	6-234	Hose Assembly (Water Wash Check Valve Reducer to Interstage Air-Bleed Actuator P3 Inlet)	2-80.4	
Hose Assembly (Flow Divider Right Side Primary to Manifold Assembly)	6-67	6-229	Hose Assembly (Water Wash Tee Check Valve to Interstage Air-Bleed Actuator P3 Inlet)	2-80.6	
Hose Assembly (Flow Divider Right Side Secondary to Manifold Assembly)	6-71	6-240	Hose Assembly (Water Wash Kit Installation to Airframe Quick Disconnect Shelf)	2-80.10	
Hose Assembly (Fuel Boost Pump to Main Fuel Filter)	6-61	6-210	Ignition Coil and Cable Assembly.....	7-5	7-41
Hose Assembly (Fuel Check Valve to Fuel Boost Pump)	6-63	6-218	Ignition Exciter.....	7-15	7-94
Hose Assembly (Fuel Control to Oil Cooler)	6-57	6-196	Inlet Housing Cover Assembly (AVIM).....	2-57	2-461
Hose Assembly (Fuel Control to Starting Fuel Solenoid Valve).....	6-75	6-253	In-Line Fuel Filter Assembly.....	6-41	6-153
Hose Assembly (Inlet Housing to Oil Drain Cock)	8-63	8-215	Interstage Air-Bleed Actuator (With Water Wash Kit P/N 2-200-071-54 Installed)	2-8.1	2-40.1
Hose Assembly (Inlet Housing to Oil Scavenge Tee).....	8-61	8-207	Interstage Air Bleed Actuator (Without Water Wash Kit P/N 2-200-071-54 Installed)	2-8	2-28
Hose Assembly (In-Line Fuel Filter to Flow Divider)	6-59	6-203	Interstage Air-Bleed Actuator	2-7	2-21
Hose Assembly (Interstage Air-Bleed Actuator to Air Diffuser Assembly)	2-76	2-534	Left- and Right-Hand Bus Bar Assemblies.....	4-11	4-51
Hose Assembly (Interstage Air-Bleed Actuator to Fuel Control)	2-74	2-528	Left- and Right-Hand Fuel Manifold Assemblies.....	6-20	6-78
Hose Assembly (Main Fuel Filter to Fuel Control)	6-73	6-247	Lower Compressor Housing.....	2-25	2-178
Hose Assembly (Main Oil Pump to Dual Chip Detector).....	8-49	8-135	Main Electrical Cable Assembly (Nine Connector).....	7-21	7-126.10

INDEX (Continued)

Subject	Para/ Task	Page	Install (cont)		
Install (cont)			Start Fuel Nozzles.....	6-28	6-116
Main Electrical Cable Assembly (Six Connector)	7-21.1	7-138	Starter Drive Assembly	5-16	5-95
Main Fuel Filter and Bracket	6-35	6-136.1	Starter Gearbox Filter.....	8-75	8-254
Main Oil Pump and Scavenge			Starter Fuel Solenoid Valve.....	6-53	6-184
Oil Screen	8-4	8-15	Stator Vane Assemblies.....	2-30	2-234
No. 2 Bearing Package (AVIM)	2-47	2-427	Thermocouple Harness		
No. 2 Bearing Pressure Oil			Assemblies (AVIM).....	4-25	4-110
Strainer	8-79	8-261	Thermocouple Jumper Lead.....	4-6	4-21
No. 3 Bearing Package (AVIM)	2-72	2-515	Third Turbine Nozzle Support (AVIM).....	4-32	4-143
No. 4 and 5 Bearing Filter	8-83	8-271	Torquemeter Head Assembly(AVIM).....	9-14	9-49
No. 4 and 5 Bearing Oil Tubes (AVIM).....	4-44	4-252	Torquemeter Junction Box (AVIM).....	9-5	9-13
No. 4 and 5 Bearing Package			Tube and Hose Assembly (Accessory Gearbox Collector to Tube Assembly)	8-69	8-237
Seals (AVIM).....	4-40	4-202	Tube Assembly (Hose Assembly to Primer Tube Assembly).....	6-79	6-267
Oil Cooler Assembly.....	8-11	8-35	Tube Assembly (Inlet Housing to Main Oil Pump)	8-51	8-140
Oil Drain Cock.....	8-87	8-284	Tube Assembly (No. 4 and 5 Bearing Scavenge Connector to Hose Assembly)	8-57	8-170
Oil Filler Assembly and Oil Filler Strainer	8-22	8-60	Tube Assembly (Tube and Hose Assembly to Accessory Gearbox Assembly).....	8-71	8-246
Oil Filter Cap and Stem Assembly and Oil Filter Element.....	8-27	8-70	Tube Assembly (Water Wash Check Valve to Air Diffuser Assembly)	2-80.2	2-556.3
Oil Level Float Assembly (AVIM)	8-109	8-346	Upper Compressor Housing.....	2-24	2-149
Oil Level Indicator	8-101	8-321			
Oil Pump Check Valve (AVIM)	8-4.2	8-20.3	Install Engine Into Shipping and Storage Container.....	1-113	1-589
Oil Temperature Transmitter	8-15	8-45			
Output Shaft(AVIM).....	9-10	9-31	Install Engine Maintenance Sling	1-30	1-111
Output Shaft Seal and Housing Assembly	2-52	2-447			
Output Shaft Support Housing (AVIM).....	2-63	2-490			
Overspeed Drive and Outlet Cover Assembly	5-23	5-114			
Primer Tube Assembly	6-24	6-107			
RTV in First Stage Stator Vane Assembly	2-30.1	2-253.1			
Seal.....	5-5.3	5-24.3			
Seal and Liner Assembly.....	5-5.4	5-24.4			
Seal Assembly	5-5.6	5-24.7			
Second Turbine Disc Assembly (AVIM).....	4-56	4-324			
Second Turbine Nozzle, Spacer, and Case (AVIM).....	4-61	4-387			
Spark Igniters.....	7-10	7-78			

INDEX (Continued)

Subject	Para/ Task	Page	Subject	Para/ Task	Page
J					
Jumper Lead, Thermocouple, See Thermocouple Jumper Lead			Location and Description of Major Components.....	1-9	1-5
Junction Box (AVIM), Torquemeter- See Torquemeter Junction Box (AVIM)			Lubrication System	1-20	1-34
L					
Lead, Thermocouple Jumper - See Thermocouple Jumper Lead			Lubricating Oil, Change from MIL-L-7808 to MIL-L-23699 - See Change from MIL-L-7808 to MIL-L-23699 Lubricating Oil		
Leakage, Check for Static Oil - See Check for Static Oil Leakage			Lubricating Oil, Change from MIL-L-23699 to MIL-L-7808 - See Change from MIL-L-23699 to MIL-L-7808 Lubricating Oil		
Leakage (No. 2 Bearing Package) (AVIM), Check for Seal - See Check for Seal Leakage (No. 2 Bearing Package) (AVIM)			M		
Leakage (No. 4 and 5 Bearing) (AVIM), Check for Seal - See Check for Seal Leakage (No. 4 and 5 Bearing) (AVIM)			Magnesium Alloys, Touch Up Magnesium and - See Touch Up Magnesium and Magnesium Alloys		
Left- and Right-Hand Bus Bar Assemblies			Magnesium and Magnesium Alloys, Touch Up - See Touch Up Magnesium and Magnesium Alloys		
Clean.....	4-8	4-42	Main Electrical Cable Assembly (Nine Connector)		
Inspect	4-9	4-43	Clean.....	7-17	7-111
Install	4-11	4-51	Inspect	7-18	7-113
Remove.....	4-7	4-35	Install	7-21	7-26.10
Test.....	4-10	4-44	Main Electrical Cable Assembly (Nine Connector) (cont)		
Left- and Right-Hand Fuel Manifold Assemblies			Remove.....	7-16	7-99
Clean.....	6-17	6-68	Repair	7-19	7-115
Inspect	6-18	6-70	Test.....	7-20	7-116.1
Left- and Right-Hand Fuel Manifold Assemblies (cont)			Main Electrical Cable Assembly (Six Connector)		
Install	6-20	6-78	Clean.....	7-17.1	7-112.1
Remove.....	6-16	6-57	Inspect	7-18.1	7-114.1
Repair	6-19	6-72	Install	7-21.1	7-138
Level Float Assembly (AVIM), Oil - See Oil Level Float Assembly (AVIM)			Remove.....	7-16.1	7-110.1
Level Indicator, Oil, - See Oil Level Indicator			Repair	7-19.1	7-116
Limits, Standard Torque - See Standard Torque Limits			Test.....	7-20.1	7-126
Liner (AVIM), Combustion Chamber -See Combustion Chamber Liner (AVIM)			Main Fuel Filter and Bracket		
			Assemble	6-34	6-133
			Clean.....	6-31	6-126
			Disassemble	6-30	6-123
			Inspect	6-32	6-128
			Install	6-35	6-136
			Remove.....	6-29	6-119

INDEX (Continued)

TM 55-2840-254-23

Subject	Para/ Task	Page	Subject	Para/ Task	Page
Main Fuel Filter and Bracket (cont)			Maximum Continuous Power Check.....	1-107	1-497
Repair (Ten Bolt Holes)	6-33	6-132	Maximum Continuous Power Check, Forty Percent - See Forty Percent Maximum Continuous Power Check		
Repair (Eight Bolt Holes)	633.1	6-132.1	Maximum Continuous Power Check, Seventy-Five Percent - See Seventy- Five Percent Maximum Continuous Power Check		
Main Oil Pump and Scavenge Oil Screen			Maximum Power, Adjust - See Adjust Maximum Power		
Clean.....	8-2	8-12	Maximum Power Check	1-107	1-502
Inspect.....	83	8-14	Maximum Trim, Adjust - See Adjust Maximum Trim		
Install.....	8-4	8-15	Meter Check, Vibration - See Vibration Meter Check		
Remove.....	8-1	8-7	MIL-L-7808 Lubricating Oil, Change from MIL-L-23699 - See Change from MIL- L-23699 to MIL-L-7808 Lubricating Oil		
Maintenance Allocation Chart		B-1	MIL-L-7808 to MIL-L-23699 Lubricating Oil, Change from - See Change from MIL-L-7808 to MIL-L-23699 Lubricating Oil		
Maintenance Checks and Services, Preventive - See Preventive Maintenance Checks and Services			MIL-L-23699 Lubricating Oil, Change from MIL-L-7808 - See Change from MIL- L-7808 to MIL-L-23699 Lubricating Oil		
Maintenance Forms, Records and Reports	1-2	1-1	MIL-L-23699 to MIL-L-7808 Lubricating Oil, Change from - See Change from MIL-L-23699 to MIL-L-7808 Lubricating Oil		
Maintenance Practices, Standard - See Standard Maintenance Practices			Minor Servicing	1-94	1-369
Maintenance Procedures	1-443		Months, Represerve Engine in Storage Over Six - See Represerve Engine in Storage Over Six Months		
Maintenance Sling, Install Engine - See Install Engine Maintenance Sling					
Maintenance Sling, Remove Engine - See Remove Engine Maintenance Sling					
Maintenance Stand, Install Engine on - See Install Engine on Maintenance Stand					
Maintenance Stand, Remove Engine from - See Remove Engine from Maintenance Stand					
Major Components, Location and Description of - See Location and Description of Major Components					
Manifold Assemblies - See Left- and Right-Hand Fuel Manifold Assemblies					
Manufactured Items, Illustrated List of - See Illustrated List of Manufactured Items					
Mark Shipping and Storage Container	1-114	1-615			
Materials List, Expendable Supplies and - See Expendable Supplies and Materials List					

N

Names and Designations, Official
 Nomenclature - See Official Nomenclature, Names
 and Designations

N1 Overspeed (AVIM), Inspect Engine
 after - See Inspect Engine after N1 Overspeed (AVIM)
N2 Governor Operation Check 1-1071-512
N2 Overspeed (AVIM), Inspect Engine
 after - See Inspect Engine after N2 Overspeed (AVIM)

INDEX (Continued)

Subject	Para/ Task	Page	Subject	Para/ Task	Page
No. 2 Bearing Package (AVIM)			No. 4 and 5 Bearing Package (AVIM)		
Assemble	2-46	2-417	Clean	4-38	4-198
Clean	2-44	2-411	Inspect	4-39	4-200
Disassemble.....	2-43	2-402	No 4 and 5 Bearing Package Seals (AVIM)		
Inspect.....	2-45	2-414	Install	4-40	4-202
Install.....	2-47	2-427	Remove.....	4-37	4-185
Remove	2-42	2-395			
No. 2 Bearing Package (AVIM), Check for Seal Leakage - See Check for Seal Leakage (No.2 Bearing Package) (AVIM)			Nomenclature, Names, and Designations, Official - See Official Nomenclature, Names, and Designations		
No. 2 Bearing Pressure Oil Strainer			Normal Shutdown Procedure	1-107	1-521
Clean.....	8-77	8-259	Nozzle and Support (AVIM), Third Turbine - See Third Turbine Nozzle and Support (AVIM)		
Inspect.....	8-78	8-260	Nozzle (AVIM), First Turbine - See First Turbine Nozzle (AVIM)		
Install.....	8-79	8-261	Nozzle (AVIM), Fourth Stage Power Turbine - See Fourth Stage Power Turbine Nozzle (AVIM)		
Remove	8-76	8-257	Nozzle, Spacer, and Case (AVIM), Second Turbine - See Second Turbine Nozzle, Spacer, and Case (AVIM)		
No. 2 Bearing Pressure Oil Strainer, Service - See Service No 2 Bearing Pressure Oil Strainer			Nozzles, Start Fuel - See Start Fuel Nozzles		
No. 3 Bearing Package (AVIM)					
Assemble	2-71	2-513	O		
Clean.....	2-69	2-508	Object Ingestion, Inspect Engine after Foreign - See Inspect Engine after Foreign Object Ingestion		
Disassemble.....	2-68	2-506	Official Nomenclature, Names, and Designations	1-6	1-2
Inspect.....	2-70	2-511	Oil, Change from MIL-L-7808 to MIL-L-23699 Lubricating - See Change from MIL-L-7808 to MIL-L-23699 Lubricating Oil		
Install.....	2-72	2-515	Oil, Change from MIL-L-23699 to MIL-L-7808 Lubricating - See Change from MIL-L-23699 to MIL-L-7808 Lubricating Oil		
Remove	2-67	2-501			
No. 4 and 5 Bearing (AVIM), Check for Seal Leakage - See Check for Seal Leakage (No 4 and 5 Bearing) (AVIM)					
No. 4 and 5 Bearing Filter					
Clean.....	8-81	8-269			
Inspect.....	8-82	8-270			
Install.....	8-83	8-271			
Remove	8-80	8-263			
No. 4 and 5 Bearing Oil Filter, Service - See Service No. 4 and 5 Bearing Oil Filter					
No. 4 and 5 Bearing Oil Tubes (AVIM)					
Clean.....	4-42	4-249			
Inspect.....	4-43	4-250			
Install.....	4-44	4-252			
Remove	4-41	4-245			

Subject	Para/ Task	Page	Subject	Para/ Task	Page
Oil Cooler Assembly			Oil Filter Element, Service 011 Filter Cap and Stem Assembly and - See Service Oil Filter Cap and Stem Assembly and Oil Filter Element		
Assemble	8-10	8-33			
Clean	8-7	8-29	Oil Filter, Service No 4 and 5 Bearing - See Service No 4 and 5 Bearing Oil		Filter
Disassemble	8-6	8-26			
Inspect	8-8	8-31	Oil Leakage, Check for Static - See Check for Static Oil Leakage		
Install	8-11	8-35	Oil Level Float Assembly (AVIM)		
Remove	-5	8-21	Assemble	8-108	8-344
Repair	8-9	8-32	Clean	8-105	8-340
Oil Drain Cock			Disassemble	8-104	8-339
Clean	85	8-281	Inspect	8106	8-342
Inspect	8-86	8-283	Install	8-109	8-346
Install	8-87	8-284	Remove	8-103	8-335
Remove	84	8-279	Repair	8-107	8-343
Oil Filler Assembly and Oil Filler Strainer			Oil Level Indicator		
Assemble	8-21	8-57	Adjust	8-102	8-327
Clean	8-18	8-52	Assemble	8-100	8-315
Disassemble	8-17	8-50	Clean	8-97	8-309
Inspect	8-19	8-54	Disassemble	8-96	8-305
Install	22	8-60	Inspect	8-98	8-311
Remove	8-16	8-47	Install	8-101	8-321
Repair	8-20	8-56	Remove	8-95	8-301
Oil Filler Strainer, Oil Filler Assembly and - See Oil Filler Assembly and Oil Filler Strainer			Repair	8-99	8-313
Oil Filler Strainer, Service - See Service Oil Filler Strainer			Oil Lines - See Hose Assembly and Tube Assembly		
Oil Filter Cap and Stem Assembly and Oil Filter Element			Oil Pump, Adjust - See Adjust Oil Pump		
Clean	8-24	66	Oil Pump and Scavenge Oil Screen, Main - See Main Oil Pump and Scavenge Oil Screen		
Inspect	8-25	8-68	Oil Screen, Main Oil Pump and Scavenge - See Main Oil Pump and Scavenge Oil Screen		
Install	8-27	8-70	Oil Screen, Service Scavenge - See Service Scavenge Oil Screen		
Remove	8-23	8-63	Oil Strainer, No. 2 Bearing Pressure - See No. 2 Bearing Pressure Oil Strainer		
Repair	8-26	8-69	Oil Strainer, Service No. 2 Bearing Pressure - See Service No. 2 Bearing Pressure Oil Strainer		
Oil Filter Cap and Stem Assembly and Oil Filter Element, Service - See Service Oil Filter Cap and Stem Assembly and Oil Filter Element			Oil System, Drain Engine - See Drain Engine Oil System		
Oil Filter Element, Oil Filter Cap and Stem Assembly and - See Oil Filter Cap and Stem Assembly and Oil Filter Element					

INDEX (Continued)

Subject	Para/ Task	Page	Subject	Para/ Task	Page
Oil System, Inspect Contaminated - See			Overspeed (AVIM), Inspect Engine after N2 - See Inspect Engine after N2 Overspeed (AVIM)		
Oil System, Service Engine - See Service Engine Oil System			Overspeed Drive and Outlet Cover Assembly		
Oil Temperature Transmitter			Assemble 5-22	5-110	
Clean.....8-13	8-43		Backlash Check 5-23 1	5-116	
Inspect.....8-14	8-44		Clean -19	5-105	
Install.....8-15	8-45		Disassemble 5-28	5-101	
Remove.....8-12	8-41		Inspect 5-20	5-107	
Oil Tubes (AVIM), No. 4 and 5 Bearing - See No 4 and 5 Bearing Oil Tubes (AVIM)			Install 5-23	5-114	
Operation Check, N2 Governor - See N2 Governor Operation Check			Remove..... 5-17	5-99	
Outlet Cover Assembly, Overspeed Drive and - See Overspeed Drive and Outlet Cover Assembly			Repair 5-21	5-109	
Output Shaft (AVIM)			Overtorque (AVIM), Inspect Engine after Power Turbine - See Inspect Engine after Power Turbine Overtorque (AVIM)		
Clean.....9-7	9-26		P		
Inspect.....9-8	9-28		Package		
Install.....9-10	9-31		Fuel Boost Pump Assembly 6-15	6-56	
Remove.....6	9-19		Fuel Control 6-8	6-36	
Repair.....9-9	930		Package (AVIM), No.2 Bearing - See No. 2 Bearing Package (AVIM)		
Output Shaft Seal and Housing Assembly			Parts, Repair - See Repair Parts		
Clean.....2-49	2-436		Percent Maximum Continuous Power Check, Forty - See Forty Percent Maximum Continuous Power Check		
Inspect.....2-50	2-437		Percent Maximum Continuous Power Check, Seventy-Five - See Seventy- Five Percent Maximum Continuous Power Check		
Install.....2-52	2-447		Place in Service Field Replacement First and Second Turbine Disc Assembly (AVIM) 4-72	4-469	
Remove.....28	2-431		Power, Adjust Maximum - See Adjust Maximum Power		
Repair.....2-51	2-438		Power Check, Maximum - See Maximum Power Check		
Output Shaft Support Housing (AVIM)			Power Check, Maximum Continuous - See Maximum Continuous Power Check		
Assemble 2-62	2-484		Power Check, Forty Percent Maximum Continuous - See Forty Percent Maximum Continuous Power Check		
Clean.....2-60	2-478				
Disassemble.....2-59	2-470				
Inspect.....261	2-481				
Install.....2-63	2-490				
Remove.....2-58	2-465				
Overhaul and Retirement Schedule 1-105	1-441				
Overspeed (AVIM), Inspect Engine after N1 - See Inspect Engine after N1 Overspeed (AVIM)					

Subject	Para/ Task	Page	Subject	Para/ Task	Page
Power Check, Intermediate - See Intermediate Power Check			Preserve and Prepare Engine for Shipment or Storage	1-111	1-555
Power Check, Seventy-Five Percent Maximum Continuous - See Seventy- Five Percent Maximum Continuous Power Check			Pressure Oil Strainer, No. 2 Bearing - See No. 2 Bearing Pressure Oil Strainer		
Power Turbine (AVIM), Combustion Section and - See Combustion Section and Power Turbine (AVIM)			Pressure Oil Strainer, Service No.....2 Bearing - See Service No. 2 Bearing Pressure Oil Strainer		
Power Turbine Nozzle (AVIM), Fourth Stage - See Fourth Stage Power Turbine Nozzle (AVIM)			Pressurized Shipping and Storage Container, Inspect -See Inspect Pressurized Shipping and Storage Container		
Power Turbine Overtorque (AVIM), Inspect Engine after - See Inspect Engine after Power Turbine Overtorque (AVIM)			Prestart Check Procedure	1-107	1-458
Power Turbine Rotor (AVIM), Fourth Stage - See Fourth Stage Power Turbine Rotor (AVIM)			Prevent Enemy Use, Destruction of Army Material to - See Destruction of Army Material to Prevent Enemy Use		
Power Turbine Rotor (AVIM), Third Stage - See Third Stage Power Turbine Rotor (AVIM)			Preventive Maintenance Checks and Services		1-239
Practices and Procedures, Standard - See Standard Practices and Procedures			Primer Tube Assembly Clean	6-22	6-104
Practices, Standard Maintenance - See Standard Maintenance Practices			Inspect	6-23	6-106
Preparation for Storage and Shipment	1-4	1-2	Install	6-24	6-107
Preparation for Storage or Shipment, Fuel Boost Pump Assembly - See Fuel Boost Pump Assembly			Remove.....	6-21	6-101
Preparation for Storage or Shipment, Fuel Control - See Fuel Control			Priming, Fuel Control - See Fuel Control Priming		
Prepare and Inspect Shipping and Storage Container	1-112	1-581	Principles of Operation		1-13
Prepare Engine for Shipment or Storage, Preserve and - See Preserve and Prepare Engine for Shipment or Storage			Procedure, Engine Starting - See Engine Starting Procedure		
Preserve Fuel Boost Pump Assembly	6-14	6-55	Procedure, Normal Shutdown - See Normal Shutdown Procedure		
Fuel Control.....	6-7	6-31	Procedure, Prestart Check - See Prestart Check Procedure		
			Procedures, Maintenance - See Maintenance		Procedures
			Procedures, Standard Practices and - See Standard Practices and Procedures		
			Procedures, Troubleshooting - See Troubleshooting Procedures		
			Pump, Adjust Oil - See Adjust Oil Pump		
			Pump and Scavenge Oil Screen, Main Oil - See Main Oil Pump and Scavenge Oil Screen		

INDEX (Continued)

Subject	Para/ Task	Page	Subject	Para/ Task	Page
Pump Assembly, Fuel Boost - See Fuel Boost Pump Assembly			Remove (cont)		
Q			Flow Divider and Bracket	6-42	6-159
Quality Assurance/Quality Control (QAIQC)	1-5	1-2	Fourth Stage Power Turbine Nozzle (AVIM)	4-45	4-269
Quality Control (QA/QC), Quality Assurance/ - See Assurance/Quality Control (QA/QC)		Quality	Fourth Stage Power Turbine Rotor (AVIM)	4-33	4-151
R			Fuel Boost Pump Assembly	69	6-39
Rating, Engine - See Engine Rating Receipt, Service Upon - See Service Upon Receipt			Fuel Check Valve	6-46	6-171
Recommendations (EIR), Reporting Equipment Improvement - See Reporting Equipment Improvement Recommendations (EIR)			Fuel Control	6-1	6-5
Records and Reports, Maintenance Forms - See Maintenance Forms, Records and Reports			Fuel Drain Valve	3-1	3-3
References		A-1	Hose Assembly (Air Diffuser Assembly to Fuel Control)	2-79	2-550
References, Directional - See Directional References			Hose Assembly (Compressor Housing to Inlet Housing)	2-77	2-536
Remove			Hose Assembly (Dual Chip Detector to Accessory Gearbox Assembly)	8-42	8-107
Accessory Gear Assembly (AVIM)	5-8	5-45	Hose Assembly (Dual Chip Detector to Accessory Gearbox Collector)	8-44	8-118
Accessory Gearbox Assembly	5-1	5-3	Hose Assembly (Dual Chip Detector to Air Diffuser Assembly)	8-46	8-128
Air Diffuser Assembly (AVIM)	2-36	2-351	Hose Assembly (Flow Divider Left Side Primary to Manifold Assembly)	6-64	6-223
Anti-Icing Air Gallery Cover	2-14	2-51	Hose Assembly (Flow Divider Left Side Secondary to Manifold Assembly)	6-68	6-231
Check Valve Assembly	8-18.1	8-40.1	Hose Assembly (Flow Divider Right Side Primary to Manifold Assembly)	6-66	6-227
Chip Detector	8-88	8-287	Hose Assembly (Flow Divider Right Side Secondary to Manifold Assembly)	6-70	6-237
Combustion Section and Power Turbine (AVIM)	3-5	3-11	Hose Assembly (Fuel Boost Pump to Main Fuel Filter)	6-60	6-206
Compressor Bleed Band	2-9	2-41	Hose Assembly (Fuel Check Valve to Fuel Boost Pump)	6-62	6-214
Compressor Rotor Blades	2-31	2-255	Hose Assembly (Fuel Control to Oil Cooler)	6-56	6-193
Diffuser Curl	4-73	4-479	Hose Assembly (Fuel Control to Starting Fuel Solenoid Valve)	6-74	6-250
Dual Chip Detector	8-28	8-73	Hose Assembly (Inlet Housing to Oil Drain Cock)	8-628	-209
Exit Vane Assembly	4-78	4-489	Hose Assembly (Inlet Housing to Oil Scavenge Tee)	8-60	8-204
Fireshield Assembly	4-12	4-65	Hose Assembly (In-Line Fuel Filter to Flow Divider)	6-58	6-199
Fireshield Section	4-16	4-79	Hose Assembly (Interstage Air- Bleed Actuator to Air Diffuser Assembly)	2-75	2-532
First Turbine Disc Assembly (AVIM)	4-62	4-397	Hose Assembly (Interstage Air- Bleed Actuator to Fuel Control)	2-73	2-525
First Turbine Nozzle (AVIM)	4-67	4-429	Hose Assembly (Main Fuel Filter to Fuel Control)	6-72	6-244
			Hose Assembly (Main Oil Pump to Dual Chip Detector)	8-48	8-133

Subject	Para/ Task	Page
Remove (cont)		
Hose Assembly (Main Oil Pump to Inlet Housing Oil Scavenge Tee)	8-52	8-148
Hose Assembly (Main Oil Pump to No.4 and 5 Bearing Scavenge Tube Assembly).....	8-54	8-156
Hose Assembly (Accessory Gearbox Assembly to Check Valve Assembly)	8-38	8-97
Hose Assembly (Oil Cooler to Inlet Housing)	8-36	8-93
Hose Assembly (Oil Cooler to In-Line Fuel Filter)	6-54	6-189
Hose Assembly (Oil Cooler to Pressure Connector)	8-408-103	
Hose Assembly (Oil Filter to Starter Drive).....	8-64	8-221
Hose Assembly (Pressure Connector to No. 4 and 4 Bearing Filter).....	8-58	8-178
Hose Assembly (Starter Drive to Tube and Hose Assembly)	8-66	8-226
Hose Assembly (Starting Fuel Solenoid Valve to Tube Assembly)	6-76	6-256
Hose Assembly (Water Wash Check Valve Elbow to Interstage Air-Bleed Actuator T/C Inlet)	2-80.7	
Hose Assembly (Water Wash Check Valve Reducer to Interstage Air-Bleed Actuator P3 Inlet)	2-80.3	
Hose Assembly (Water Wash Tee Check Valve to Interstage Air-Bleed Actuator P3 Inlet)	2-80.5	
Hose Assembly (Water Wash Kit Installation to Interstage Airframe Quick Disconnect Shelf).....	2-80.9	
Ignition Coil and Cable Assembly 7-1 ..	7-3	
Ignition Exciter	7-11	7-85
Inlet Housing Cover Assembly (AVIM).....	2-53	2-455
In-Line Fuel Filter Assembly	6-36	6-141
Interstage Air-bleed Actuator (With Water Wash Kit P/N 2-300-071-54 Installed)	2-1.1	2-11.1
Interstage Air-Bleed Actuator (Without Water Wash Kit P/N 2-200-011-54 Installed)	2-1	2-5
Left-and Right-Hand Bus Bar Assemblies.....	4-7	4-35
Left-and Right-Hand Fuel Manifold Assemblies.....	6-16	6-57
Lower Compressor Housing.....	2-20	2-104
Main Electrical Cable Assembly (Nine Connector).....	7-16	7-99

Subject	Para/ Task	Page
Remove (cont)		
Main Electrical Cable Assembly (Six Connector).....	7-16.1	7-110.1
Main Fuel Filter and Bracket.....	6-29	6-119
Main Oil Pump and Scavenge Oil Screen	8-1	8-7
No. 2 Bearing Package (AVIM).....	2-42	2-395
No. 2 Bearing Pressure Oil Strainer	8-76	8-257
No. 3 Bearing Package Seals (AVIM)	2-67	2-501
No. 4 and5 Bearing Filter.....	8-80	8-263
No. 4 and 5 Bearing Oil Tubes (AVIM)	4-41	4-245
No. 4 and 5 Bearing Package (AVIM)	4-37	4-185
Oil Cooler Assembly	8-5	8-21
Oil Drain Cock	8-84	8-279
Oil Filler Assembly and Oil Filler Strainer	8-16	8-47
Oil Filter Cap and Stem Assembly and Oil Filter Element	8-23	8-63
Oil Level Float Assembly (AVIM)	8-103	8-335
Oil Level Indicator.....	8-95	8-301
Oil Pump Check Valve (AVIM).....	8-4.1	8-20.1
Oil Temperature Transmitter.....	8-12	8-41
Output Shaft (AVIM)	9-6	9-19
Output Shaft Seal and Housing Assembly	2-48	2-431
Output Shaft Support Housing (AVIM)	2-58	2-465
Overspeed Drive and Outlet Cover Assembly	5-17	5-99
Primer Tube Assembly	6-21	6-101
Seal 5-5.2	5-2	4.2
Seal and Liner Assembly.....	5-5.1	5-24.1
Seal Assembly	5-5.5	5-24.5
Second Turbine Disc Assembly (AVIM)	4-53	4-313
Second Turbine Nozzle, Spacer, and Case (AVIM)	4-57	4-335
Spark Igniters	7-6	7-69
Start Fuel Nozzles	6-25	6-111
Starter Drive Assembly.....	5-12	5-81
Starter Gearbox Filter.....	8-72	8-249
Starting Fuel Solenoid Valve	6-49	6-177
Stator Vane Assemblies	2-26	2-219
Thermocouple Harness Assemblies (AVIM)	4-20	4-97
Thermocouple Jumper Lead.....	4-1	4-5
Third Turbine Nozzle and Support (AVIM)	4-26	4-123
Torquemeter Head Assembly (AVIM)	9-11	9-39
Torquemeter Junction Box (AVIM)	9-1	9-3
Tube and Hose Assembly (Accessory Gearbox Collector to Tube Assembly).....	8-68	8-231
Tube Assembly (Hose Assembly to Primer Tube Assembly).....	6-78	6-262

INDEX (Continued)

Subject	Para/ Task	Page	Subject	Para/ Task	Page
Remove (cont)			Repair (cont)		
Tube Assembly (Inlet Housing to Main Oil Pump)	8-50	8-137	Left- and Right-Hand Fuel Manifold Assemblies	6-19	6-72
Tube Assembly (No 4 and 5 Bearing Scavenge Connector to Hose Assembly)	8-56	8-162	Main Electrical Cable Assembly (Nine Connector)	7-19	7-115
Tube Assembly (Tube and Hose Assembly to Accessory Gearbox Assembly)	8-70	8-243	Main Electrical Cable Assembly (Six Connector).....	7-19.1	7-116
Tube Assembly (Water Wash Check Valve to Air Diffuser Assembly)	2-80.3		Main Fuel Filter and Bracket (Ten Bolt Holes)	633	6-132
Upper Compressor Housing	2-19	2-71	Main Fuel Filter and Bracket (Eight Bolt Holes)	633.1	6-132 1
Remove Engine from Maintenance Stand.....	1-291-105		Oil Cooler Assembly	8-9	8-32
Remove Engine from Shipping and Storage Container	1-26	1-63	Oil Filter Assembly and Oil Filter Strainer	8-20	8-56
Remove Engine Maintenance Sling.....	1-31	1-116	Oil Filter Cap and Stem Assembly and Oil Filter Element	8-26	8-69
Repair			Oil Level Float Assembly (AVIM) ...	8-107	8-343
Accessory Gearbox Assembly	6-5	6-24	Oil Level Indicator	8-99	8-313
Air Diffuser Assembly	2-40	2-375	Output Shaft (AVIM)	9-9	9-30
Air Diffuser Assembly (AVIM)	2-39	2-371	Output Shaft Seal and Housing Assembly	2-51	2-438
Air Inlet Housing Assembly	2-66	2-499	Overspeed Drive and Outlet Cover Assembly	5-21	5-109
Anti-Icing Ar Gallery Cover	2-17	2-60	Second Turbine Nozzle, Spacer, and Case (AVIM)	4- 60	4-369
Combustion Chamber Housing (AVIM).....	3-21	3-217	Spark Igniters	7-9	7-75
Combustion Chamber Liner (AVIM) 3-18		3-197	Starter Drive Assembly	5-15	5-87
Combustion Chamber Vane Assembly (AVIM)	3-15	3-180	Starting Fuel Solenoid Valve	6-52	6-183
Compressor Bleed Band.....	2-12	2-46	Stator Vane Assemblies	2-29	2-232
Compressor Housing	2-23	2-147	Thermocouple Harness Assemblies (AVIM)	4-23	4-105
Compressor Rotor Blades	234	2-312	Thermocouple Jumper Lead.....	4-4	4-14
Diffuser Curl	4-76	4-485	Third Stage Power Turbine Rotor (AVIM)	4-52	4-309
Dual Chip Detector	8-32	8-83	Third Turbine Nozzle and Support (AVIM)	4-30	4-140
Exit Valve Assembly	4-81	4-501	Torquemeter Junction Box (AVIM)	9-4	9-11
First Turbine Disc Assembly (AVIM).....	4-65	4-410	Torquemeter Head Assembly (AVIM)	9-13.1	9-48.2
First Turbine Rotor Case (AVIM) ...	4-70	4-445	Repair Parts	1-24	1-42
Fourth Stage Power Turbine Nozzle (AVIM).....	4-48	4-280	Repair Parts; Special Tools; Test, Measurement, and Diagnostic Equipment (TMDE); and Support Equipment		1-41
Fuel Boost Pump Assembly	6-12	6-44	Repair Splines and Gears, Clean, Inspect and - See Clean, Inspect and Repair Splines and Gears		
Fuel Control	6-4.1	6-18.1	Reporting Equipment Improvement Recommendations (EIR).....	1-71-3	
Ignition Coil and Cable Assembly ..	7-4	7-35	Reports, Maintenance Forms, Records and - See Maintenance Forms, Records and Reports		
Ignition Exciter	7-14	7-92			
Inlet Housing Cover Assembly (AVIM).....	2-56	2-460			
Interstage Air-Bleed Actuator.....	2-5	2-18			

Subject	Para/ Task	Page
Represerve Engine In Storage Over Six Months.....	1-115	1-620
Retirement Schedule, Overhaul and - See Overhaul and Retirement Schedule		
Right- and Left-Hand Bus Bar Assemblies - See Left- and Right-Hand Bus Bar Assemblies		
Rotor (AVIM), Fourth Stage Power Turbine - See Fourth Stage Power Turbine Rotor (AVIM)		
Rotor (AVIM), Third Stage Power Turbine - See Third Stage Power Turbine Rotor (AVIM)		
Rotor Blades, Compressor - See Compressor Rotor Blades		
Rotor Case (AVIM), First Turbine - See First Turbine Rotor Case (AVIM)		
RTV in First Stage Stator Vane Assembly, Install	2-30.1	2-253.1
S		
Safety, Care, and Handling.....	1-12	1-11
Scavenge Oil Screen, Main Oil Pump and See Main Oil Pump and Scavenge Oil Screen		
Scavenge Oil Screen, Service - See Service Scavenge Oil Screen		
Schedule, Overhaul and Retirement - See Overhaul and Retirement Schedule		
Scope.....	1-1	1-1
Scratching, Gouging, or Wear, Determine Depth of Damage from Chafing, Denting - See Determine Depth of Damage from Chafing, Denting, Scratching, Gouging, or Wear		
Screen, Main Oil Pump and Scavenge Oil - See Main Oil Pump and Scavenge Oil Screen		
Screen, Service Scavenge Oil - See Service Scavenge Oil Screen		

Subject	Para/ Task	Page
Seal and Housing Assembly, Output Shaft - See Output Shaft Seal and Housing Assembly		
Seal Leakage (No.2 Bearing Package) (AVIM), Check for - See Check for Seal Leakage (No 2 Bearing Package) (AVIM)		
Seal Leakage (No. 4 and 5 Bearing) (AVIM), Check for - See Check for Seal Leakage (No. 4 and 5 Bearing) (AVIM)		
Seals (AVIM), No. 4 and 5 Bearing Package - See No. 4 and 5 Bearing Package Seals (AVIM)		
Second Turbine Disc Assembly (AVIM)		
Clean	4-54	4-320
Inspect	4-55	4-322
Install	4-56	4-324
Remove.....	4-53	4-313
Second Turbine Nozzle, Spacer, and Case (AVIM)		
Clean	4-58	4-345
Inspect	4-59	4-347
Install	4-61	4-387
Remove.....	4-57	4335
Repair	4-60	4-369
Section, Accessory Gear - See Accessory Gear Section		
Section, Combustion - See Combustion Section		
Section, Compressor - See Compressor Section		
Section, Turbine - See Turbine Section		
Service Accessory Gearbox Chip		
Detector	1-86	1-268
Service Dual Chip Detector.....	1-86	1-270
Service Engine Oil System	1-74	1-221
Service Fuel Control Filter and Air-Bleed Poppet Valve	1-101	1-414
Service In-Line Fuel Filter	1-103	1-429
Service Interstage Air-Bleed Actuator Strainer.....	1-104	1-434

INDEX (Continued)

Subject	Para/ Task	Page	Subject	Para/ Task	Page
Service Main Fuel Filter	1-102	1-425	Shipping and Storage Container, Inspect Pressurized - See Inspect Pressurized Shipping and Storage Container		
Service No 2 Bearing Pressure Oil Strainer.....	1-97	1-380			
Service No. 4 and 5 Bearing Oil Filter	1-98	1-384	Shipping and Storage Container, Install Engine into - See Install Engine into Shipping and Storage Container		
Service Oil Filler Strainer	1-96	1-375			
Service Oil Filter Cap and Stem Assembly and Oil Filter Element	1-99	1-397	Shipping and Storage Container, Mark - See Mark Shipping and Storage Container		
Service Scavenge Oil Screen	1-100	1-402			
Service Starter Gearbox Filter	1-95	1-371	Shipping and Storage Container, Prepare and Inspect - See Prepare and Inspect Shipping and Storage Container		
Service Upon Receipt		1-43			
Services, Preventive Maintenance Checks and - See Preventive Maintenance Checks and Services			Shipping and Storage Container, Remove Engine from - See Remove Engine from Shipping and Storage Container		
Servicing		1-219			
Servicing, Minor - See Minor Servicing			Shutdown Procedure, Normal - See Normal Shutdown Procedure		
Seventy-Five Percent Maximum Continuous Power Check.....	1-107	1-493	Six Months, Represerve Engine in Storage Over - See Represerve Engine in Storage Over Six Months		
Shaft (AVIM), Output - See Output Shaft (AVIM)					
Shaft Seal and Housing Assembly, Output - See Output Shaft Seal and Housing Assembly			Sleeve on Hoses, Install Spiral Chafing - See Install Spiral Chafing Sleeve on Hoses		
Shaft Support Housing (AVIM), Output - See Output Shaft Support Housing (AVIM)					
Shipment, Fuel Boost Pump Assembly, Preparation for Storage or - See Fuel Boost Pump Assembly, Preserve and Package			Sling, Install Engine Maintenance - See Install Engine Maintenance Sling		
Shipment, Fuel Control, Preparation for Storage or - See Fuel Control, Preserve and Package			Sling, Remove Engine Maintenance - See Remove Engine Maintenance Sling		
Shipment or Storage, Preserve and Prepare Engine for - See Preserve and Prepare Engine for Shipment or Storage			Solenoid Valve, Starting Fuel - See Starting Fuel Solenoid Valve		
Shipment, Preparation for Storage and - See Preparation for Storage and Shipment			Spacer, and Case (AVIM), Second Turbine Nozzle - See Second Turbine Nozzle, Spacer, and Case (AVIM)		

Subject	Para/ Task	Page
Spark Igniters		
Clean.....	7-7	7-73
Inspect.....	7-8	7-74
Install.....	7-10	7-78
Remove.....	7-6	7-69
Repair.....	7-9	7-75
Special Inspections.....	1-78	1-239
Special Tools, TMDE, and Support Equipment.....	1-23	1-41
Spiral Chafing Sleeve on Hoses, Install - See Install Spiral Chafing Sleeve on Hoses		
Splines and Gears, Clean, Inspect and Repair - See Clean, Inspect and Repair Splines and Gears		
Stall (Surge), Inspect Engine after Compressor - See Inspect Engine after Compressor Stall (Surge)		
Stand, Install Engine on Maintenance See Install Engine on Maintenance Stand		
Stand, Remove Engine from Maintenance - See Remove Engine from Maintenance Stand		
Standard Maintenance Practices	1-117	1-627
Standard Practices and Procedures	1-627	
Standard Torque Limits	1-623	
Standard Torque Values.....	1-116	1-623
Start Fuel Nozzles		
Clean.....	6-26	6-114
Inspect.....	6-27	6-115
Install.....	6-28	6-116
Remove.....	6-25	6-111

Subject	Para/ Task	Page
Starter Drive Assembly		
Clean	5-13	5-85
Inspect	5-14	5-86
Install	5-16	5-95
Remove.....	5-12	5-81
Repair	5-15	5-87
Starter Gearbox Filter		
Clean	8-73	8-262
Inspect	8-74	8-253
Install	8-75	8-254
Remove.....	8-72	8-249
Starter Gearbox Filter, Service - See Service Starter Gearbox Filter		
Starting Fuel Solenoid Valve		
Clean	6-50	6-181
Inspect	6-51	6-182
Install	6-53	6-184
Remove.....	6-49	6-177
Repair	6-52	6-183
Starting Procedure, Engine - See Engine Starting Procedure		
Static Oil Leakage, Check for - See Check for Static Oil Leakage		
Stator Vane Assemblies		
Clean	2-27	2-228
Inspect	2-28	2-230
Install	2-30	2-234
Remove.....	2-26	2-219
Repair	2-29	2-232
Stem Assembly and Oil Filter Element, Oil Filter Cap and - See Oil Filter Cap and Stem Assembly and Oil Filter Element		
Stem Assembly and Oil Filter Element, Service Oil Filter Cap and - See Service Oil Filter Cap and Stem Assembly and Oil Filter Element		
Storage, Activate Engine after - See Activate Engine after Storage		
Storage and Shipment, Preparation for - See Preparation for Storage and Shipment		
Storage Container, Inspect Pressurized Shipping and - See Inspect Pressurized Shipping and Storage Container		

INDEX (Continued)

Subject	Para/ Task	Page	Subject	Para/ Task	Page
Storage Container, Install Engine into Shipping and - See Install Engine into Shipping and Storage Container			Support Housing (AVIM), Output Shaft - See Output Shaft Support Housing (AVIM)		
Storage Container, Mark Shipping and - See Mark Shipping and Storage Container			(Surge), Inspect Engine after Compressor Stall - See Inspect Engine after Compressor Stall (Surge)		
Storage Container, Prepare and Inspect Shipping and - See Prepare and Inspect Shipping and Storage Container			Symptom Index.....	1-32	1-119
Storage Container, Remove Engine from Shipping and - See Remove Engine from Shipping and Storage Container			System, Drain Engine Oil - See Drain Engine Oil System		
Storage or Shipment, Fuel Boost Pump Assembly, Preparation for - See Fuel Boost Pump Assembly, Preserve and Package			System, Electrical and Ignition - See Electrical and Ignition System		
Storage or Shipment, Fuel Control, Preparation for - See Fuel Control, Preserve and Package			System, Fuel - See Fuel System		
Storage Over Six Months, Engine in - See Engine in Storage Over Six Months			System, Inspect Contaminated Fuel - See Inspect Contaminated Fuel System		
Storage, Preserve and Prepare Engine for Shipment or Storage - See Preserve and Prepare Engine for Shipment or Storage			System, Inspect Contaminated Oil - See Inspect Contaminated Oil System		
Strainer, No. 2 Bearing Pressure Oil - See No. 2 Bearing Pressure Oil Strainer			System, Lubrication - See Lubrication System		
Strainer, Oil Filler Assembly and Oil Filler - See Oil Filler Assembly and Oil Filler Strainer			System, Service Engine Oil - See. Service Engine Oil System		
Strainer, Service No. 2 Bearing Pressure Oil - See Service No. 2 Bearing Pressure Oil Strainer			System, Torquemeter - See Torquemeter System		
Strainer, Service Oil Filler - See Service Oil Filler Strainer					
Support (AVIM), Third Turbine Nozzle and - See Third Turbine Nozzle and Support (AVIM)			T		
Support Equipment, Special Tools, TMDE, and - See Special Tools, TMDE, and Support Equipment			Temperature Transmitter, Oil - See Oil Temperature Transmitter		
			Test		
			Chip Detector	8-92	8-294
			Dual Chip Detector.....	834	8-87
			Left- and Right-Hand Bus Bar Assemblies	4-10	4-44
			Main Electrical Cable Assembly (Nine Connector).....	7-20	7-116.1
			Main Electrical Cable Assembly (Six Connector)	7-20.1	7-126
			Thermocouple Harness Assemblies (AVIM).....	4-24	4-108
			Thermocouple Jumper Lead	4-5	4-16
			Test Engine (AVIM)	1-107	1-457
			Test, Vibration - See Vibration Test		

Subject	Para/ Task	Page	Subject	Para/ Task	Page
Thermocouple Harness Assemblies (AVIM)			Torquemeter Head Assembly (AVIM)		
Clean	4-21	4-102	Clean	9-12	9-44
Inspect	4-22	4-103	Inspect	9-13	9-46
Install	4-25	4-110	Install	9	14 9-49
Remove	4-20	4-97	Remove	9-11	9-39
Repair	4-23	4-105	Repair	9-13.1	9-48.2
Test	4-24	4-108			
Thermocouple Jumper Lead			Torquemeter Junction Box (AVIM)		
Clean	4-2	4-11	Clean	9-2	9-8
Inspect	4-3	4-12	Inspect	9-3	9-9
Install	6	421	Install	9-5	9-13
Remove	4-1	4-5	Remove	9-1	9-3
Repair	4-4	4-14	Repair	9-4	9-11
Test	4-5	4-16			
Third Stage Power Turbine Rotor (AVIM)			Torquemeter System	1-21	1-40
Clean	4-50	4-303	Touch Up Magnesium and Magnesium Alloys	1-119	1-642
Inspect	4-51	4-305			
Repair	4-52	4-309	Transmitter, Oil Temperature - See Oil Temperature Transmitter		
Third Turbine Nozzle and Support (AVIM)			Trim, Adjust Maximum - See Adjust Maximum Trim		
Assemble	4-31	41	Trim Check, Ground Idle - See Ground Idle Trim Check		
Clean	4-28	4-130	Troubleshooting		1-119
Disassemble	4-27	4-128	Troubleshooting Procedures	1-33	1-121
Inspect	4-29	4-132			
Install	4-32	4-143	Tube and Hose Assembly (Accessory Gearbox Collector to Tube Assembly)		
Remove	4-26	4-123	Install	8-69	8-237
Repair	4-30	1 40	Remove	8-68	8-231
Time, Check Engine Coastdown - See Check Engine Coastdown Time			Tube Assembly (Hose Assembly to Primer Tube Assembly)		
Tools and Equipment, Common - See Common Tools and Equipment			Install	6-79	6-267
Tools, TMDE and Support, Special - See Special Tools, TMDE, and Support Equipment			Remove	6-78	6-262
Torque Limits, Standard - See Standard Torque Limits			Tube Assembly (Inlet Housing to Main Oil Pump)		
Torque Values, Standard - See Standard Torque Values			Install	8-51	8-140
			Remove	8-50	8-137
			Tube Assembly (No. 4 and 5 Bearing Scavenge Connector to Hose Assembly)		
			Install	8-57	8-170
			Remove	8-56	8-162
			Tube Assembly, Primer - See Primer Tube Assembly		

INDEX (Continued)

Subject	Para/ Task	Page	Subject	Para/ Task	Page
Tube Assembly (Tube and Hose Assembly to Accessory Gearbox Assembly)			V		
Install.....	8-71	8-246	Values, Standard Torque - See Standard Torque Values		
Remove.....	8-70	8-243			
Tube Assembly (Water Wash Check Valve to Air Diffuser Assembly)			Valve, Fuel Check - See Fuel Check Valve		
Install.....	2-80.2		Valve, Fuel Drain - See Fuel Drain Valve		
Remove.....	2-80.3				
Tubes (AVIM), No. 4 and 5 Bearing Oil - See No. 4 and 5 Bearing Oil Tubes (AVIM)			Valve Assembly, Check - See Check Valve Assembly		
Turbine Disc Assembly (AVIM), First - See First Turbine Disc Assembly (AVIM)			Valve, Starting Fuel Solenoid - See Starting Fuel Solenoid Valve		
Turbine Disc Assembly (AVIM), Second - See Second Turbine Disc Assembly (AVIM)			Vane Assemblies, Stator - See Stator Vane Assemblies		
Third Nozzle and Support (AVIM), Third - See Third Turbine Nozzle and Support (AVIM)			Vane Assembly (AVIM), Combustion Chamber - See Combustion Chamber Vane Assembly		
Turbine Nozzle (AVIM), First - See First Turbine Nozzle (AVIM)			Vane Assembly, Exit - See Exit Vane Assembly		
Turbine Nozzle (AVIM), Fourth Stage Power - See Fourth Stage Power Turbine Nozzle (AVIM)			Vibration Meter Check.....	1-107	1-475
Turbine Nozzle, Spacer, and Case (AVIM), Second - See Second Turbine Nozzle, Spacer, and Case (AVIM)			Vibration Test	1-107	1-474
Turbine Overtorque (AVIM), Inspect Engine after Power - See Inspect Engine after Power Turbine Overtorque (AVIM)			W		
Turbine Rotor (AVIM), Fourth Stage Power - See Fourth Stage Power Turbine Rotor (AVIM)			Wash Compressor (With Water Wash Kit 2-200-271-54 Installed) ..	1-106.1	1-446.1
Turbine Rotor (AVIM), Third Stage Power - See Third Stage Power Turbine Rotor (AVIM)			Wash Compressor (Without Water Wash Kit 2-200-271-54 Installed) ..	1-106	1-445
Turbine Rotor Case (AVIM), First - See First Turbine Rotor Case (AVIM)			Waveoff Check	1-107	1-492
Turbine Section.....	1-16	1-20	Wiring Diagram	D-1	
			Wear, Determine Depth of Damage from Chafing, Denting, Scratching, Gouging, or - See Determine Depth of Damage from Chafing, Denting, Scratching, Gouging, or Wear		

INDEX (Continued)

Subject	Par/ Task	Page	Subject	Para/ Task	Page
Storage Container, Install Engine into Shipping and — See Install Engine into Shipping and Storage Container			Support (AVIM), Third Turbine Nozzle and — See Third Turbine Nozzle and Support (AVIM)		
Storage Container, Mark Shipping and — See Mark Shipping and Storage Container			Support Equipment, Special Tools, TMDE, and — See Special Tools, TMDE, and Support Equipment		
Storage Container, Prepare and Inspect Shipping and — See Prepare and Inspect Shipping and Storage Container			Support Housing (AVIM), Output Shaft — See Output Shaft Support Housing (AVIM)		
Storage Container, Remove Engine from Shipping and — See Remove Engine from Shipping and Storage Container			(Surge), Inspect Engine after Compressor Stall — See Inspect Engine after Compressor Stall (Surge)		
Storage or Shipment, Fuel Boost Pump Assembly, Preparation for — See Fuel Boost Pump Assembly Preparation for Storage or Shipment			Symptom Index	1-32	1-119
Storage or Shipment Fuel Control, preparation for — See Fuel Control Preparation for Storage or Shipment			System, Drain Engine Oil — See Drain Engine Oil System		
Storage Over Six Months, Engine in — See Engine in Storage Over Six Months			System, Electrical and Ignition — See Electrical and Ignition System		
Storage, Preserve and Prepare Engine for Shipment or Storage — See Preserve and Prepare Engine for Shipment or Storage			System, Fuel — See Fuel System		
Strainer, No. 2 Bearing Pressure Oil — See No. 2 Bearing Pressure Oil Strainer			System, Inspect Contaminated Fuel — See Inspect Contaminated Fuel System		
Strainer, Oil Filler Assembly and Oil Filler — See Oil Filler Assembly and Oil Filler Strainer			System, Inspect Contaminated Oil — See Inspect Contaminated Oil System		
Strainer, Service No. 2 Bearing Pressure Oil — See Service No. 2 Bearing pressure Oil Strainer			System, Lubrication — See Lubrication System		
Strainer, Service Oil Filler — See Service Oil Filler Strainer			System, Service Engine Oil — See Service Engine Oil System		
			System, Torquemeter — See Torquemeter System		
			T		
			Temperature Transmitter, Oil — See Oil Temperature Transmitter		

INDEX (Continued)

Subject	Para/ Task	Page	Subject	Para/ Task	Page
Test			Time, Check Engine Coastdown — See Check Engine Coastdown Time		
Chip Detector	8-92	8-294			
Dual Chip Detector	8-34	8-87			
Left-and Right-Hand Bus Bar Assembles	4-10	4-44	Tools and Equipment, Common — See Common Tools and Equipment		
Main Electrical Cable Assembly (Nine Connector)	7-20	7-116.1			
Main Electrical Cable Assembly (Six Connector)	7-20.1	7-126	Tools, TMDE and Support, Special — See Special Tools, TMDE, and Support Equipment		
Thermocouple Harness Assemblies (AVIM)	4-24	4-108	Torque Limits, Standard — See Standard Torque Limits		
Thermocouple Jumper Lead	4-5	4-16			
Test Engine (AVIM)	1-107	1-457	Torque Values, Standard — See Standard Torque Values		
Test, Vibration — See Vibration Test					
Thermocouple Harness Assemblies (AVIM)			Torquemeter Head Assembly (AVIM)		
Clean	4-21	4-102	Clean	9-12	9-44
Inspect	4-22	4-103	Inspect	9-13	9-46
Install	4-25	4-110	Install	9-14	9-49
Remove	4-20	4-97	Remove	9-11	9-39
Repair	4-23	4-105	Repair	9-13.1	9-48.2
Test	4-24	4-108			
Thermocouple Jumper Lead			Torquemeter Junction Box (AVIM)		
Clean	4-2	4-11	Clean	9-2	9-8
Inspect	4-3	4-12	Inspect	9-3	9-9
Install	4-6	4-21	Install	9-5	9-13
Remove	4-1	4-5	Remove	9-1	9-3
Repair	4-4	4-14	Repair	9-4	9-11
Test	4-5	4-16			
Third Stage Power Turbine Rotor (AVIM)			Torquemeter System	1-21	1-40
Clean	4-50	4-303			
Inspect	4-51	4-305	Touch Up Magnesium and Magnesium Alloys	1-119	1-642
Repair	4-52	4-309			
Third Turbine Nozzle and Support (AVIM)			Transmitter, Oil Temperature — See Oil Temperature Transmitter		
Assemble	4-31	4-141	Trim, Adjust Maximum — See Adjust Maximum Trim		
Clean	4-28	4-130			
Disassemble	4-27	4-128	Trim Check, Ground Idle — See Ground Idle Trim Check		
Inspect	4-29	4-132			
Install	4-32	4-143	Troubleshooting		1-119
Remove	4-26	4-123			
Repair	4-30	4-140	Troubleshooting Procedures	1-33	1-121

INDEX (Continued)

Subject	Para/ Taak	Page	Subject	Para/ Task	Page
Tube and Hose Assembly (Accessory Gearbox Collector to Tube Assembly)			Turbine Nozzle (AVIM), First — See First Turbine Nozzle (AVIM)		
Install	8-69	8-237	Turbine Nozzle (AVIM), Fourth Stage Power — See Fourth Stage Power Turbine Nozzle (AVIM)		
Remove	8-68	6-231	Turbine Nozzle, Spacer, and Case (AVIM), Second — See Second Turbine Nozzle, Spacer, and Case (AVIM)		
Tube Assembly (Hose Assembly to Primer Tube Assembly)			Turbine Overtorque (AVIM), Inspect Engine after Power — See Inspect Engine after Power Turbine Overtorque (AVIM)		
Install	6-79	6-267	Turbine Rotor (AVIM), Fourth Stage Power — See Fourth Stage Power Turbine Rotor (AVIM)		
Remove	6-78	6-262	Turbine Rotor (AVIM), Third Stage Power — See Third Stage Power Turbine Rotor (AVIM)		
Tube Assembly (Inlet Housing to Main Oil Pump)			Turbine Rotor Case (AVIM), First — See First Turbine Rotor Case (AVIM)		
Install	8-51	6-140	Turbine Section	1-16	1-20
Remove	8-50	6-137			
Tube Assembly (No. 4 and 5 Bearing scavenge Connector to Hose Assembly)					
Install	8-57	8-170			
Remove	6-56	8-162			
Tube Assembly, Primer — See Primer Tube Assembly					
Tube Assembly (Tube and Hose Assem- bly to Accessory Gearbox Assembly)					
Install	8-71	6-246			
Remove	8-70	8-243			
Tube Assembly (Water Wash Check Valve to Air Diffuser Assembly)					
Install	2-80.2				
Remove	2-80.3				
Tubes (AVIM), No. 4 and 5 Bearing Oil — See No. 4 and 5 Bearing Oil Tubes AWIM)					
Turbine Disc Assembly (AVIM), First — See First Turbine Disc Assembly (AVIM)					
Turbine Disc Assembly (AVIM), Second — See Second Turbine Disc Assembly (AVIM)					
Third Nozzle and Support (AVIM), Third — See Third Turbine Nozzle and Support (AVIM)					

V

Values, Standard Torque — See Standard
Torque Values

Valve, Fuel Check — See Fuel Check
Valve

Valve, Fuel Drain — See Fuel Drain Valve

Valve, Oil Pump Check (AVIM) — See Oil
Pump Check Valve (AVIM)

Valve, Starting Fuel Solenoid — See
Starting Fuel Solenoid Valve

Vane Assemblies, Stator — See Stator
Vane Assemblies

INDEX (Continued)

Subject	Para/ Task	Page	Subject	Para/ Task	Page
Vane Assembly (AVIM), Combustion Chamber — See Combustion Chamber Vane Assembly			Wash Compressor (With Water Wash Kit 2-200271-54 Installed)	1-106.1	1-446.1
Vane Assembly, Exit — See Exit Vane Assembly			Waveoff Check	1-107	1-492
Vibration Meter Check	1-107	1475	Wiring Diagram		D-1
Vibration Test	1-107	1-474	Wear, Determine Depth of Damage from Chafing, Denting, Scratching, Gouging, or — See Determine Depth of Damage from Chafing, Denting, Scratching, Gouging, or Wear		
w					
Wash Compressor (Without Water Wash Kit 2-200-271-54 installed)	1-106	1-445			

By Order of the Secretary of the Army:

E. C. MEYER
General, United States Army
Chief of Staff

Official:

ROBERT M. JOYCE
Major General, United States Army
The Adjutant General

DISTRIBUTION:

To be distributed in accordance with DA Form 12-31, Organizational Maintenance requirements for CH-47 B/C&D Aircraft.

These are the instructions for sending an electronic 2028

The following format must be used if submitting an electronic 2028. The subject line must be exactly the same and all fields must be included; however only the following fields are mandatory: 1, 3, 4, 5, 6, 7, 8, 9, 10, 13, 15, 16, 17, and 27.

From: "Whomever" <whomever@wherever.army.mil>

To: 2028@redstone.army.mil

Subject: DA Form 2028

1. **From:** Joe Smith
2. **Unit:** home
3. **Address:** 4300 Park
4. **City:** Hometown
5. **St:** MO
6. **Zip:** 77777
7. **Date Sent:** 19-OCT-93
8. **Pub no:** 55-2840-229-23
9. **Pub Title:** TM
10. **Publication Date:** 04-JUL-85
11. **Change Number:** 7
12. **Submitter Rank:** MSG
13. **Submitter FName:** Joe
14. **Submitter MName:** T
15. **Submitter LName:** Smith
16. **Submitter Phone:** 123-123-1234
17. **Problem:** 1
18. **Page:** 2
19. **Paragraph:** 3
20. **Line:** 4
21. **NSN:** 5
22. **Reference:** 6
23. **Figure:** 7
24. **Table:** 8
25. **Item:** 9
26. **Total:** 123
27. **Text:**

This is the text for the problem below line 27.

RECOMMENDED CHANGES TO PUBLICATIONS AND BLANK FORMS For use of this form, see AR 25-30; the proponent agency is ODISC4.						Use Part II (reverse) for Repair Parts and Special Tool Lists (RPSTL) and Supply Catalogs/Supply Manuals (SC/SM)	DATE 8/30/02
TO: (Forward to proponent of publication or form)(Include ZIP Code) Commander, U.S. Army Aviation and Missile Command ATTN: AMSAM-MMC-MA-NP Redstone Arsenal, AL 35898						FROM: (Activity and location)(Include ZIP Code) MSG, Jane Q. Doe 1234 Any Street Nowhere Town, AL 34565	
PART 1 – ALL PUBLICATIONS (EXCEPT RPSTL AND SC/SM) AND BLANK FORMS							
PUBLICATION/FORM NUMBER TM 9-1005-433-24						DATE 16 Sep 2002	TITLE Organizational, Direct Support, And General Support Maintenance Manual for Machine Gun, .50 Caliber M3P and M3P Machine Gun Electrical Test Set Used On Avenger Air Defense Weapon System
ITEM NO.	PAGE NO.	PARA-GRAPH	LINE NO. *	FIGURE NO.	TABLE NO.	RECOMMENDED CHANGES AND REASON	
1	WP0005 PG 3		2			Test or Corrective Action column should identify a different WP number.	
<i>* Reference to line numbers within the paragraph or subparagraph.</i>							
TYPED NAME, GRADE OR TITLE MSG, Jane Q. Doe, SFC						TELEPHONE EXCHANGE/AUTOVON, PLUS EXTENSION 788-1234	SIGNATURE

EXAMPLE

TO: (Forward direct to addressee listed in publication) Commander, U.S. Army Aviation and Missile Command ATTN: AMSAM-MMC-MA-NP Redstone Arsenal, AL 35898	FROM: (Activity and location) (Include ZIP Code) MSG, Jane Q. Doe 1234 Any Street Nowhere Town, AL 34565	DATE 8/30/02
--	--	------------------------

PART II – REPAIR PARTS AND SPECIAL TOOL LISTS AND SUPPLY CATALOGS/SUPPLY MANUALS

PUBLICATION NUMBER			DATE	TITLE				
PAGE NO.	COLM NO.	LINE NO.	NATIONAL STOCK NUMBER	REFERENCE NO.	FIGURE NO.	ITEM NO.	TOTAL NO. OF MAJOR ITEMS SUPPORTED	RECOMMENDED ACTION

PART III – REMARKS (Any general remarks, corrections, or suggestions for improvement of publications and blank forms. Additional blank sheets may be used if more space is needed.)

EXAMPLE

TYPED NAME, GRADE OR TITLE MSG, Jane Q. Doe, SFC	TELEPHONE EXCHANGE/AUTOVON, PLUS EXTENSION 788-1234	SIGNATURE
---	--	-----------

RECOMMENDED CHANGES TO PUBLICATIONS AND BLANK FORMS <small>For use of this form, see AR 25-30; the proponent agency is ODISC4.</small>						Use Part II (<i>reverse</i>) for Repair Parts and Special Tool Lists (RPSTL) and Supply Catalogs/Supply Manuals (SC/SM)	DATE
TO: (<i>Forward to proponent of publication or form</i>)(<i>Include ZIP Code</i>) Commander, U.S. Army Aviation and Missile Command ATTN: AMSAM-MMC-MA-NP Redstone Arsenal, AL 35898						FROM: (<i>Activity and location</i>)(<i>Include ZIP Code</i>)	
PART 1 – ALL PUBLICATIONS (EXCEPT RPSTL AND SC/SM) AND BLANK FORMS							
PUBLICATION/FORM NUMBER TM 1-2840-254-23P						DATE 26 April 1983	TITLE Engine, Gas Turbine Model T55-L-712
ITEM NO.	PAGE NO.	PARA-GRAPH	LINE NO. *	FIGURE NO.	TABLE NO.	RECOMMENDED CHANGES AND REASON	
<i>* Reference to line numbers within the paragraph or subparagraph.</i>							
TYPED NAME, GRADE OR TITLE						TELEPHONE EXCHANGE/ AUTOVON, PLUS EXTENSION	SIGNATURE

TO: (Forward direct to addressee listed in publication) Commander, U.S. Army Aviation and Missile Command ATTN: AMSAM-MMC-MA-NP Redstone Arsenal, AL 35898	FROM: (Activity and location) (Include ZIP Code)	DATE
--	---	-------------

PART II – REPAIR PARTS AND SPECIAL TOOL LISTS AND SUPPLY CATALOGS/SUPPLY MANUALS

PUBLICATION NUMBER TM 1-2840-254-23P	DATE 26 April 1983	TITLE Engine, Gas Turbine, Model T55-L-712
--	------------------------------	--

PAGE NO.	COLM NO.	LINE NO.	NATIONAL STOCK NUMBER	REFERENCE NO.	FIGURE NO.	ITEM NO.	TOTAL NO. OF MAJOR ITEMS SUPPORTED	RECOMMENDED ACTION

PART III – REMARKS (Any general remarks or recommendations, or suggestions for improvement of publications and blank forms. Additional blank sheets may be used if more space is needed.)

TYPED NAME, GRADE OR TITLE	TELEPHONE EXCHANGE/AUTOVON, PLUS EXTENSION	SIGNATURE
----------------------------	--	-----------

RECOMMENDED CHANGES TO PUBLICATIONS AND BLANK FORMS <small>For use of this form, see AR 25-30; the proponent agency is ODISC4.</small>						Use Part II (<i>reverse</i>) for Repair Parts and Special Tool Lists (RPSTL) and Supply Catalogs/Supply Manuals (SC/SM)	DATE
TO: (<i>Forward to proponent of publication or form</i>)(<i>Include ZIP Code</i>) Commander, U.S. Army Aviation and Missile Command ATTN: AMSAM-MMC-MA-NP Redstone Arsenal, AL 35898						FROM: (<i>Activity and location</i>)(<i>Include ZIP Code</i>)	
PART 1 – ALL PUBLICATIONS (EXCEPT RPSTL AND SC/SM) AND BLANK FORMS							
PUBLICATION/FORM NUMBER TM 1-2840-254-23P						DATE 26 April 1983	TITLE Engine, Gas Turbine Model T55-L-712
ITEM NO.	PAGE NO.	PARA-GRAPH	LINE NO. *	FIGURE NO.	TABLE NO.	RECOMMENDED CHANGES AND REASON	
<i>* Reference to line numbers within the paragraph or subparagraph.</i>							
TYPED NAME, GRADE OR TITLE						TELEPHONE EXCHANGE/ AUTOVON, PLUS EXTENSION	SIGNATURE

TO: (Forward direct to addressee listed in publication) Commander, U.S. Army Aviation and Missile Command ATTN: AMSAM-MMC-MA-NP Redstone Arsenal, AL 35898	FROM: (Activity and location) (Include ZIP Code)	DATE
--	---	-------------

PART II – REPAIR PARTS AND SPECIAL TOOL LISTS AND SUPPLY CATALOGS/SUPPLY MANUALS

PUBLICATION NUMBER TM 1-2840-254-23P	DATE 26 April 1983	TITLE Engine, Gas Turbine, Model T55-L-712
--	------------------------------	--

PAGE NO.	COLM NO.	LINE NO.	NATIONAL STOCK NUMBER	REFERENCE NO.	FIGURE NO.	ITEM NO.	TOTAL NO. OF MAJOR ITEMS SUPPORTED	RECOMMENDED ACTION

PART III – REMARKS (Any general remarks or recommendations, or suggestions for improvement of publications and blank forms. Additional blank sheets may be used if more space is needed.)

TYPED NAME, GRADE OR TITLE	TELEPHONE EXCHANGE/AUTOVON, PLUS EXTENSION	SIGNATURE
----------------------------	--	-----------

RECOMMENDED CHANGES TO PUBLICATIONS AND BLANK FORMS <small>For use of this form, see AR 25-30; the proponent agency is ODISC4.</small>						Use Part II (<i>reverse</i>) for Repair Parts and Special Tool Lists (RPSTL) and Supply Catalogs/Supply Manuals (SC/SM)	DATE
TO: (<i>Forward to proponent of publication or form</i>)(<i>Include ZIP Code</i>) Commander, U.S. Army Aviation and Missile Command ATTN: AMSAM-MMC-MA-NP Redstone Arsenal, AL 35898						FROM: (<i>Activity and location</i>)(<i>Include ZIP Code</i>)	
PART 1 – ALL PUBLICATIONS (EXCEPT RPSTL AND SC/SM) AND BLANK FORMS							
PUBLICATION/FORM NUMBER TM 1-2840-254-23P						DATE 26 April 1983	TITLE Engine, Gas Turbine Model T55-L-712
ITEM NO.	PAGE NO.	PARA-GRAPH	LINE NO. *	FIGURE NO.	TABLE NO.	RECOMMENDED CHANGES AND REASON	
<i>* Reference to line numbers within the paragraph or subparagraph.</i>							
TYPED NAME, GRADE OR TITLE						TELEPHONE EXCHANGE/ AUTOVON, PLUS EXTENSION	SIGNATURE

TO: (Forward direct to addressee listed in publication) Commander, U.S. Army Aviation and Missile Command ATTN: AMSAM-MMC-MA-NP Redstone Arsenal, AL 35898	FROM: (Activity and location) (Include ZIP Code)	DATE
--	---	-------------

PART II – REPAIR PARTS AND SPECIAL TOOL LISTS AND SUPPLY CATALOGS/SUPPLY MANUALS

PUBLICATION NUMBER TM 1-2840-254-23P	DATE 26 April 1983	TITLE Engine, Gas Turbine, Model T55-L-712
--	------------------------------	--

PAGE NO.	COLM NO.	LINE NO.	NATIONAL STOCK NUMBER	REFERENCE NO.	FIGURE NO.	ITEM NO.	TOTAL NO. OF MAJOR ITEMS SUPPORTED	RECOMMENDED ACTION

PART III – REMARKS (Any general remarks or recommendations, or suggestions for improvement of publications and blank forms. Additional blank sheets may be used if more space is needed.)

TYPED NAME, GRADE OR TITLE	TELEPHONE EXCHANGE/AUTOVON, PLUS EXTENSION	SIGNATURE
----------------------------	--	-----------

The Metric System and Equivalents

Linear Measure

1 centimeter = 10 millimeters = .39 inch
 1 decimeter = 10 centimeters = 3.94 inches
 1 meter = 10 decimeters = 39.37 inches
 1 dekameter = 10 meters = 32.8 feet
 1 hectometer = 10 dekameters = 328.08 feet
 1 kilometer = 10 hectometers = 3,280.8 feet

Weights

1 centigram = 10 milligrams = .15 grain
 1 decigram = 10 centigrams = 1.54 grains
 1 gram = 10 decigrams = .035 ounce
 1 decagram = 10 grams = .35 ounce
 1 hectogram = 10 decagrams = 3.52 ounces
 1 kilogram = 10 hectograms = 2.2 pounds
 1 quintal = 100 kilograms = 220.46 pounds
 1 metric ton = 10 quintals = 1.1 short tons

Liquid Measure

1 centiliter = 10 milliliters = .34 fl. ounce
 1 deciliter = 10 centiliters = 3.38 fl. ounces
 1 liter = 10 deciliters = 33.81 fl. ounces
 1 dekaliter = 10 liters = 2.64 gallons
 1 hectoliter = 10 dekaliters = 26.42 gallons
 1 kiloliter = 10 hectoliters = 264.18 gallons

Square Measure

1 sq. centimeter = 100 sq. millimeters = .155 sq. inch
 1 sq. decimeter = 100 sq. centimeters = 15.5 sq. inches
 1 sq. meter (centare) = 100 sq. decimeters = 10.76 sq. feet
 1 sq. dekameter (are) = 100 sq. meters = 1,076.4 sq. feet
 1 sq. hectometer (hectare) = 100 sq. dekameters = 2.47 acres
 1 sq. kilometer = 100 sq. hectometers = .386 sq. mile

Cubic Measure

1 cu. centimeter = 1000 cu. millimeters = .06 cu. inch
 1 cu. decimeter = 1000 cu. centimeters = 61.02 cu. inches
 1 cu. meter = 1000 cu. decimeters = 35.31 cu. feet

Approximate Conversion Factors

<i>To change</i>	<i>To</i>	<i>Multiply by</i>	<i>To change</i>	<i>To</i>	<i>Multiply by</i>
inches	centimeters	2.540	ounce-inches	Newton-meters	.007062
feet	meters	.305	centimeters	inches	.394
yards	meters	.914	meters	feet	3.280
miles	kilometers	1.609	meters	yards	1.094
square inches	square centimeters	6.451	kilometers	miles	.621
square feet	square meters	.093	square centimeters	square inches	.155
square yards	square meters	.836	square meters	square feet	10.764
square miles	square kilometers	2.590	square meters	square yards	1.196
acres	square hectometers	.405	square kilometers	square miles	.386
cubic feet	cubic meters	.028	square hectometers	acres	2.471
cubic yards	cubic meters	.765	cubic meters	cubic feet	35.315
fluid ounces	milliliters	29.573	cubic meters	cubic yards	1.308
pints	liters	.473	milliliters	fluid ounces	.034
quarts	liters	.946	liters	pints	2.113
gallons	liters	3.785	liters	quarts	1.057
ounces	grams	28.349	liters	gallons	.264
pounds	kilograms	.454	grams	ounces	.035
short tons	metric tons	.907	kilograms	pounds	2.205
pound-feet	Newton-meters	1.356	metric tons	short tons	1.102
pound-inches	Newton-meters	.11296			

Temperature (Exact)

F	Fahrenheit temperature	5/9 (after subtracting 32)	Celsius temperature	C
----------	------------------------	----------------------------	---------------------	----------

